



Recall Service Bulletin

**Recall Service Bulletin
RSB24-120-001**

DATE: 6/20/2024

APPLIES TO: This service bulletin applies to certain model year 2022-2024 Gladiator and Metro Star, and 2023-2024 FC-94 model emergency response chassis cabs built between November 2022 and March 2024.

NHTSA/TC Id: 24V323/2024-284

CONDITION: Certain driver and officer front seats may have been installed in the cab with incorrect fasteners.

CORRECTION: Inspect seat mounting for incorrect fasteners and replace fasteners if incorrect.

LABOR ALLOCATION: 0.5 hour inspection/1.0 for repair if needed.

CLASSIFICATION: M2

PARTS NEEDED (if inspection indicates replacement is necessary):

<u>QTY</u>	<u>Part Number</u>	<u>Description</u>
8	08130150FH8Y	½-13 X1.50LG FLG Gr8 Bolt
8	0813FLN8Y	½-13FLG LK GR8 Nut
4	0124-BB1-001	½ X 2 ½ inch Flat Washer

Service Bulletins are intended for use by Professional Technicians only. They are written to guide Professional Technicians in performing service to vehicles of specific nature in conjunction with industry standards. Professional Technicians should be appropriately trained on industry standards and have the tools and equipment to perform procedures safely and properly.



Recall Service Bulletin



**Recall Service Bulletin
RSB24-120-001**

GENERAL INSTRUCTIONS:

Thoroughly review entire service bulletin before starting work. If there are questions or concerns with steps defined in this service bulletin, contact Spartan Fire, LLC. Customer & Product Support Group.

All applicable industry safety standards must be followed when performing work identified in this procedure.

Step By Step Instructions

- 1) Locate driver and officer seat mounting bolts. *See Figure 3.1*
- 2) Inspect bolts and determine the diameter of each bolt.
- 3) If they are 3/8-inch diameter, bolts will require replacement with ½ inch diameter hardware.
- 4) If bolts are already ½ inch diameter, then no further action is necessary.
- 5) If bolts are 3/8 inch, replace with ½ inch hardware as shown in figure 3.1.
- 6) Torque nuts to 74 lb-ft.

Service Bulletins are intended for use by Professional Technicians only. They are written to guide Professional Technicians in performing service to vehicles of specific nature in conjunction with industry standards. Professional Technicians should be appropriately trained on industry standards and have the tools and equipment to perform procedures safely and properly.



Recall Service Bulletin



Recall Service Bulletin RSB24-120-001

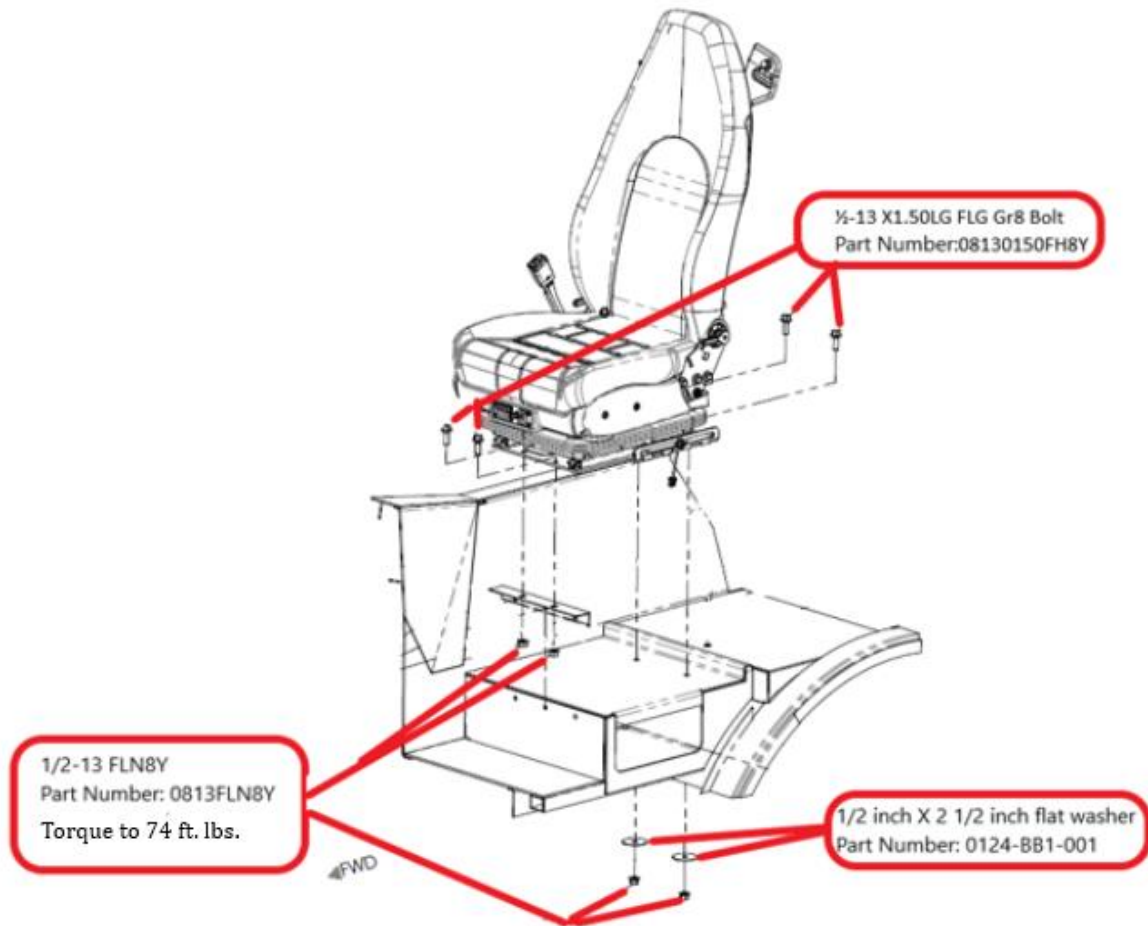

Figure 3.1

Service Bulletins are intended for use by Professional Technicians only. They are written to guide Professional Technicians in performing service to vehicles of specific nature in conjunction with industry standards. Professional Technicians should be appropriately trained on industry standards and have the tools and equipment to perform procedures safely and properly.