



VOLUNTARY RECALL CAMPAIGN

Classification: FA24-003A	Reference: NTB24-024A	Date: May 6, 2024
------------------------------	--------------------------	----------------------

VOLUNTARY SAFETY RECALL CAMPAIGN 2024 SENTRA; FRONT LH DRIVE SHAFT

This bulletin has been amended. See AMENDMENT HISTORY on the last page.
Please discard previous versions of this bulletin.

CAMPAIGN ID #: PMA37
APPLIED VEHICLES: 2024 Sentra (B18)

**Check Service COMM or Dealer Business Systems (DBS)
National Service History to confirm campaign eligibility.**

INTRODUCTION

Nissan is conducting this voluntary safety recall campaign on certain specific model year 2024 Sentra vehicles to inspect, and if necessary, replace the Front LH Drive Shaft and the CVT. This service will be performed at no charge to the customer for parts or labor.

IDENTIFICATION NUMBER

Nissan has assigned identification number PMA37 to this campaign. This number must appear on all communication and documentation of any nature dealing with this campaign.

DEALER RESPONSIBILITY

It is the dealer’s responsibility to check Service COMM or Dealer Business Systems (DBS) National Service History for the campaign status on each vehicle falling within the range of this voluntary safety recall which for any reason enters the service department. This includes vehicles purchased from private parties or presented by transient (tourist) owners and vehicles in a dealer’s inventory. **Federal law requires that new vehicles in dealer inventory which are the subject of a safety recall must be corrected prior to sale. Failure to do so can result in civil penalties by the National Highway Traffic Safety Administration.** While federal law applies only to new vehicles, Nissan strongly encourages dealers to correct any used vehicles in their inventory before they are retailed.

Bulletins are intended for use by qualified technicians, not 'do-it-yourselfers'. Qualified technicians are properly trained individuals who have the equipment, tools, safety instruction, and know-how to do a job properly and safely. **NOTE:** If you believe that a described condition may apply to a particular vehicle, DO NOT assume that it does. See your Nissan dealer to determine if this applies to your vehicle.

REPAIR OVERVIEW

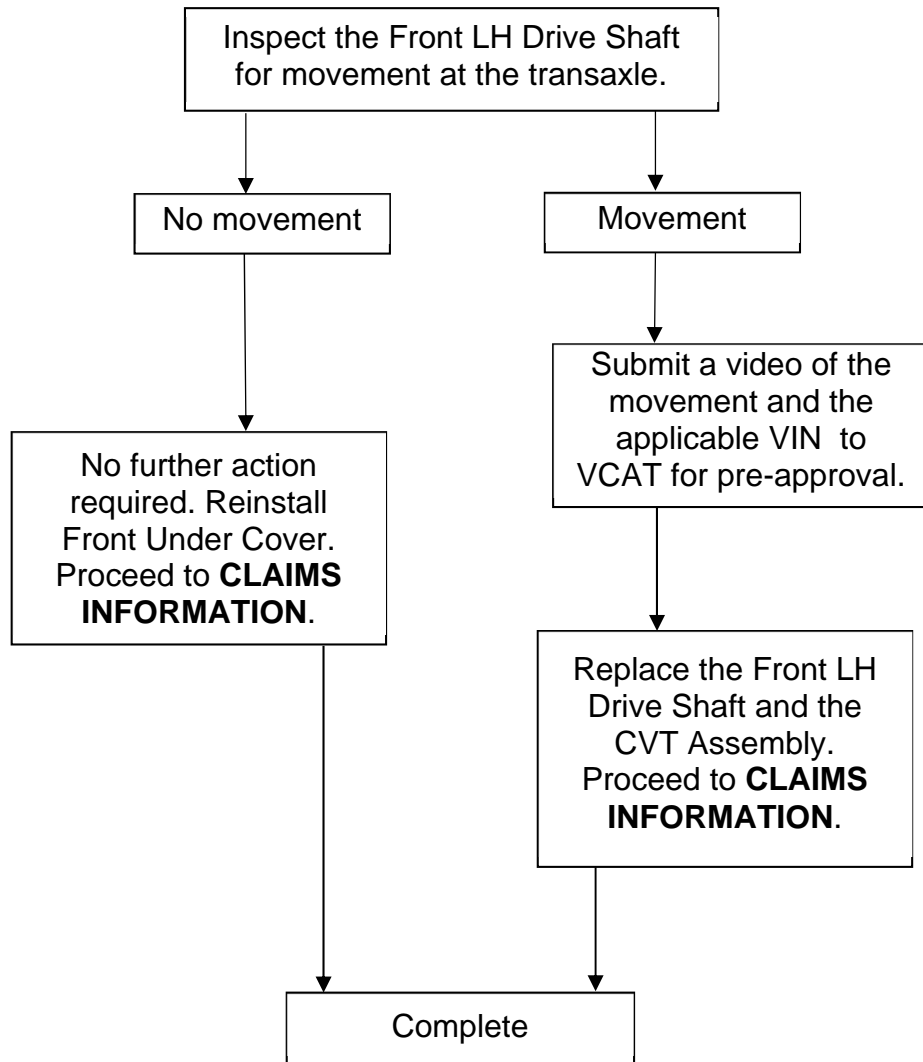

SERVICE PROCEDURE

Inspection

1. Raise and suitably support the vehicle.

2. Remove the Front Under Cover.

- Refer to the ESM: **BODY EXTERIOR, DOORS, ROOF & VEHICLE SECURITY > EXTERIOR > REMOVAL AND INSTALLATION > UNDER COVER > FRONT UNDER COVER > Removal and Installation**

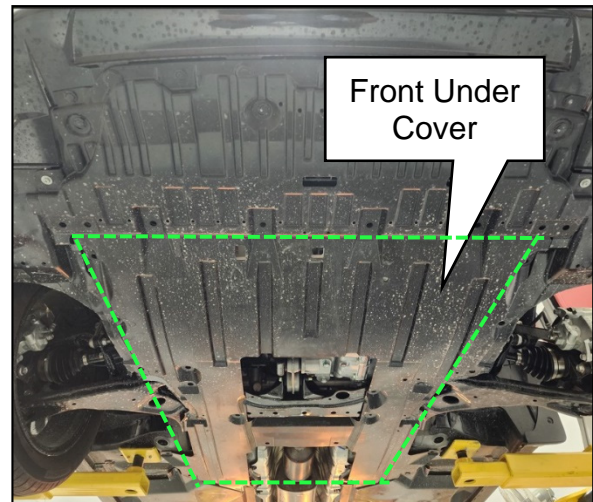

Figure 1

3. Locate the Front LH (driver side) Drive Shaft Inner Joint.

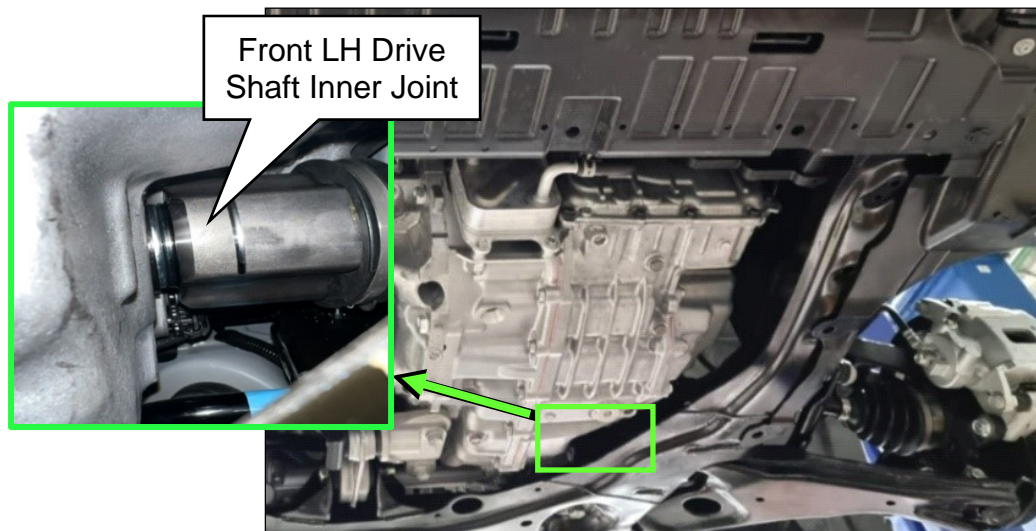

Figure 2

4. Verify the Front LH Drive Shaft is fully seated in the transaxle.

HINT: When the Front LH Drive Shaft is NOT fully seated in the transaxle, the Drive Shaft will move outward easily with little to no pry force.

- Place a long flat-blade screwdriver between the Front LH Drive Shaft and the transaxle case, as shown in Figure 3.
- Using light force, gently pry the Front LH Drive Shaft outward (away from the transaxle case) while watching the Front LH Drive Shaft Inner Joint for movement.

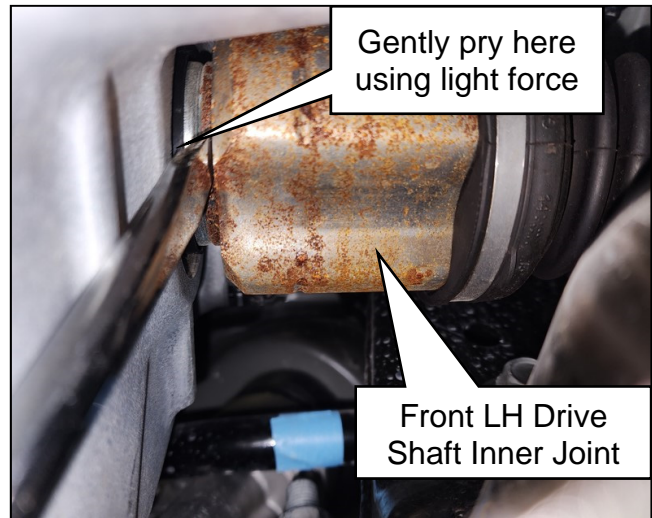

Figure 3

5. Did the Front LH Drive Shaft Inner Joint move outward when gently prying away from the transaxle case?

- Document the results on the repair order.

NO: Drive Shaft did NOT move, Good Result: No further action is necessary. Reinstall the Front Under Cover and proceed to **CLAIMS INFORMATION** on the last page.

YES: Drive Shaft moved, No Good Result: Continue to step 6.

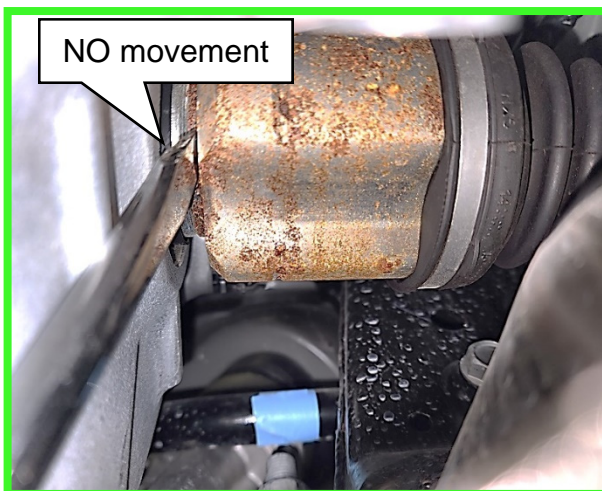

Figure 4

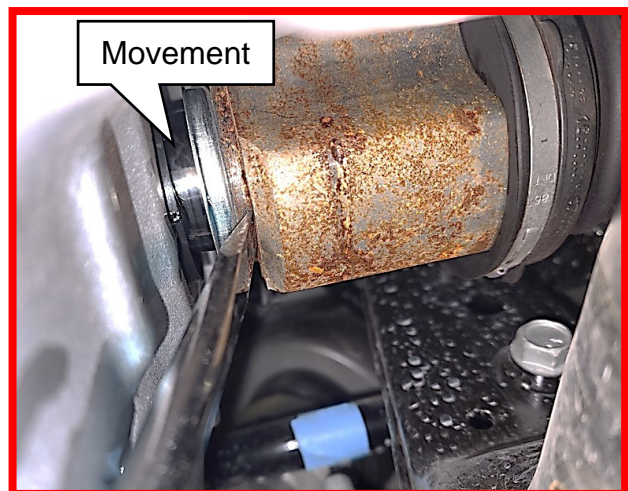

Figure 5

6. Submit a video with the movement and the applicable VIN to VCAT for pre-approval, then continue to step 7 on page 5 to replace the Front LH Drive Shaft and the CVT.

Front LH Drive Shaft Removal

New or replacement Essential Tools are available from Tech Mate online: www.techmatetools.com, or by phone: 1-833-397-3493.

When ordering, keep in mind that the tool part number prefix has changed from “J” to “NI”. For example, J-52982 is now NI-52982.

Required Special Tool - Lock Nut Chisel [Cape Chisel (NI-52982)]

- Each dealer has been previously shipped one Cape Chisel (J-52982).

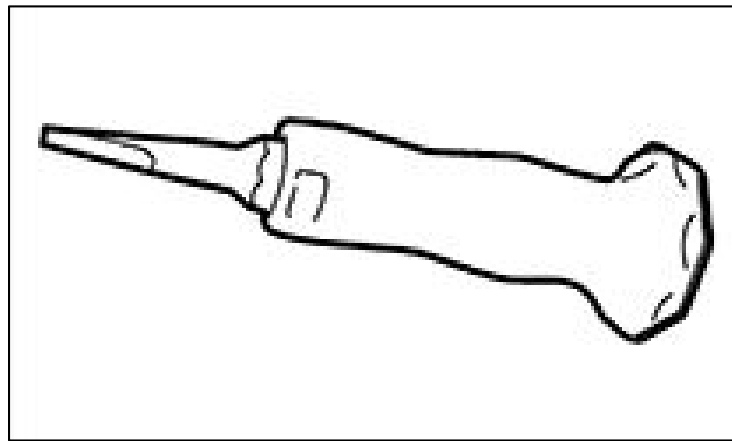

Figure 6

7. Remove the Front LH Drive Shaft and discard it.
 - Refer to the ESM: **TRANSMISSION & DRIVELINE > FRONT AXLE > REMOVAL AND INSTALLATION > FRONT DRIVE SHAFT > Removal and Installation (LH)**

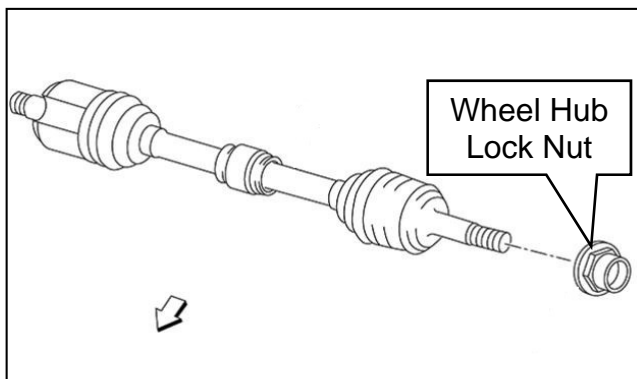

Figure 7

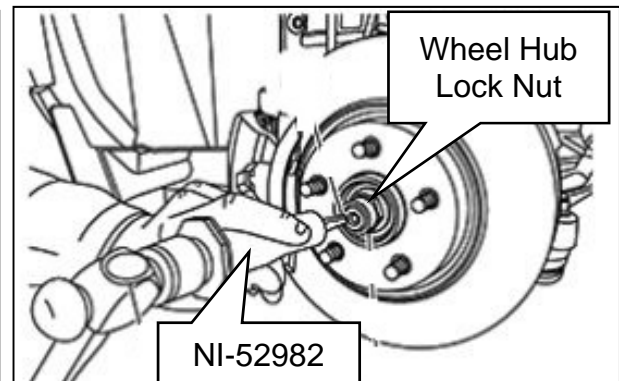

Figure 8

CVT Removal

⚠ WARNING

To avoid the risk of death or severe personal injury, do not remove the radiator cap when the engine is hot. Serious burns could occur from high pressure coolant escaping from the radiator. Perform repairs when the engine is cold. Wrap a thick cloth around the cap. Slowly turn a quarter turn to allow built-up pressure to escape. Carefully remove the cap by turning it all the way.

⚠ CAUTION

To help reduce risk of moderate personal injury and/or property damage due to improper vehicle operation following repair:

- Perform **ADDITIONAL SERVICE WHEN REPLACING TRANSAXLE ASSEMBLY** when replacing the transaxle assembly.
- Perform **ADDITIONAL SERVICE WHEN REPLACING TCM AND TRANSAXLE ASSEMBLY** when replacing the TCM and the transaxle assembly simultaneously.

NOTICE

When removing components such as hoses, tubes/lines, etc., cap or plug openings to prevent fluid from spilling and/or damage to the vehicle.

IMPORTANT: The CVT assembly should **ONLY** be replaced if the Front LH Drive Shaft had movement when inspected in step 4 and step 5 on page 4.

8. Remove the CVT assembly.
 - Refer to the ESM: **TRANSMISSION & DRIVELINE > TRANSAXLE & TRANSMISSION > CVT: RE0F15A > UNIT REMOVAL AND INSTALLATION > TRANSAXLE ASSEMBLY > Removal and Installation**

CVT Installation

CAUTION

To avoid the risk of moderate personal injury and/or damage to the vehicle:

- When replacing the transaxle, you must make sure any dowels are installed correctly during reassembly.
 - Improper alignment caused by missing dowels may cause vibration, oil leaks, or breakage of drivetrain components.
- Do not reuse O-rings or copper sealing washers to prevent leaks.
- When turning crankshaft, turn it clockwise as viewed from the front of the engine.
- When tightening the nuts for the torque converter while securing the crankshaft pulley bolt, be sure to confirm the tightening torque of the crankshaft pulley bolt.
- After the torque converter is installed to the drive plate, rotate the crankshaft several turns to check that the CVT rotates freely without binding.
- When installing the drive plate to torque converter nuts, tighten them temporarily. Then tighten the nuts to the specified torque.

9. Write down the serial number of the new transaxle assembly.

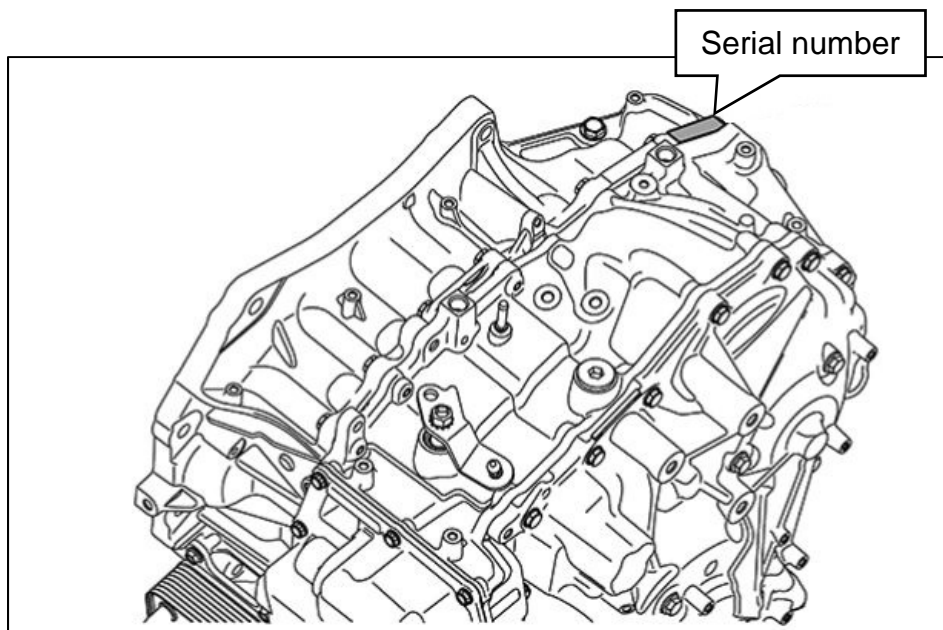

Figure 9

10. Install the CVT assembly.

- Refer to the ESM: **TRANSMISSION & DRIVELINE > TRANSAXLE & TRANSMISSION > CVT: RE0F15A > UNIT REMOVAL AND INSTALLATION > TRANSAXLE ASSEMBLY > Removal and Installation**
 - Tighten the NEW Front LH Wheel Hub Lock Nut to 165.0 N•m (17.0 kg-m, **122 ft-lb**).
 - Tighten the torque converter nuts to 51.0 N•m (5.2 kg-m, **38 ft-lb**).
 - Tighten the transaxle assembly to engine assembly mounting bolts to 62.0 N•m (6.3 kg-m, **46 ft-lb**).

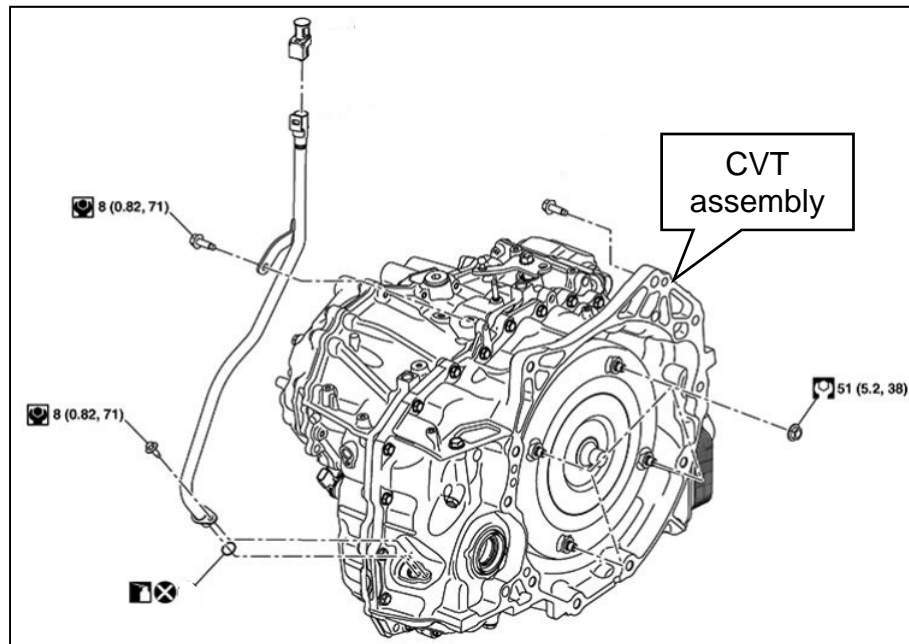

Figure 10

HINT: Do not lubricate engine assembly mounting bolts.

Bolt symbol	(A)	(B)	(C)
Insertion direction	Transaxle to cylinder block	Cylinder block to transaxle	Oil pan to transaxle
Quantity	1	3	4
Bolt length " ℓ " mm (in)	55 (2.17)	50.5 (1.988)	50.5 (1.988)
Tightening torque N·m (kg-m, ft-lb)	62.0 (6.3, 46)		

Figure 11

11. After replacing the transaxle assembly, perform **ADDITIONAL SERVICE WHEN REPLACING TRANSAXLE ASSEMBLY**.
 - Refer to the ESM: **TRANSMISSION & DRIVELINE > TRANSAXLE & TRANSMISSION > CVT: RE0F15A > BASIC INSPECTION > ADDITIONAL SERVICE WHEN REPLACING TRANSAXLE ASSEMBLY - Description**

Front LH Drive Shaft Replacement

12. Replace the Front LH Drive Shaft (Figure 12).

- Refer to the ESM: **TRANSMISSION & DRIVELINE > FRONT AXLE > REMOVAL AND INSTALLATION > FRONT DRIVE SHAFT > Removal and Installation (LH)**

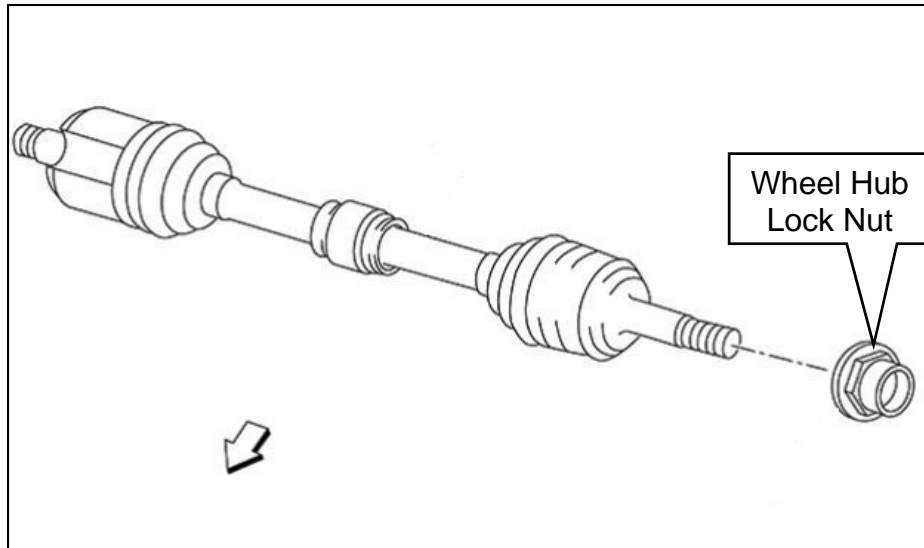

Figure 12

- Tighten the NEW lower ball joint nut to 75.0 N•m (7.7 kg-m, **55 ft-lb**).
- Tighten the NEW outer socket nut to 34.4 N•m (3.5 kg-m, **25 ft-lb**).
- Tighten the NEW stabilizer bar link nuts to 62.0 N•m (6.3 kg-m, **46 ft-lb**).
- Tighten the CVT fluid charging pipe retaining bolts to 8.0 N•m (0.82 kg-m, **71 in-lb**).
- Tighten wheel and tire assemblies to 113.0 N•m (12.0 kg-m, **83 ft-lb**).

CAUTION

To avoid the risk of moderate personal injury or damage to the vehicle:

- Ensure the circular clip is properly engaged into the transaxle, grasp the Drive Shaft housing and pull back and forth in axial direction while listening for clicking sounds.
- Do not reuse the wheel hub lock nut.
- Use a torque wrench and not a power tool to tighten the wheel hub lock nut since the Drive Shaft is assembled by press fitting.
 - Tighten the wheel hub lock nut to specification as too much torque causes axle noise and too little torque causes wheel bearing looseness.

13. Fill and adjust the CVT fluid level as necessary.
 - Refer to the ESM: **TRANSMISSION & DRIVELINE > TRANSAXLE & TRANSMISSION – CVT: RE0F15A > PERIODIC MAINTENANCE > CVT FLUID > Adjustment**
14. Reinstall the Front Under Cover.
 - Refer to the ESM: **BODY EXTERIOR, DOORS, ROOF & VEHICLE SECURITY > EXTERIOR > REMOVAL AND INSTALLATION > UNDER COVER > FRONT UNDER COVER > Removal and Installation**
15. Perform a front wheel alignment.
 - Refer to the ESM: **SUSPENSION > FRONT SUSPENSION > PERIODIC MAINTENANCE > WHEEL ALIGNMENT > Adjustment**
16. On all models, perform Radar Alignment.
 - Refer to the ESM: **CRUISE CONTROL & DRIVER ASSISTANCE > DRIVER ASSISTANCE SYSTEM > DRIVER ASSISTANCE SYSTEM > BASIC INSPECTION > DISTANCE SENSOR ALIGNMENT > Work Procedure**
17. On SV and SR models with Premium Package (With AVM), perform Front Camera Calibration.
 - Refer to the ESM: **DRIVER INFORMATION & MULTIMEDIA > AUDIO, VISUAL & NAVIGATION SYSTEM > INTELLIGENT AROUND VIEW MONITOR SYSTEM > BASIC INSPECTION > CALIBRATING CAMERA IMAGE (INTELLIGENT AROUND VIEW MONITOR) > Work Procedure**
18. On all models, perform AEB System Action Test.
 - Refer to the ESM: **BRAKES > BRAKE CONTROL SYSTEM > AUTOMATIC EMERGENCY BRAKING > BASIC INSPECTION > ACTION TEST > Work Procedure**

PARTS INFORMATION

DESCRIPTION	PART NUMBER	QUANTITY
AUTOMATIC TRANSAXLE	31020-70X8C (New Vehicles in Dealer Inv.)	1
REMAN TRANSAXLE ASSY – AUTOMATIC	3102M-70X8CRE (Retailer Vehicles)	1
SHAFT ASSY – FRONT DRIVE, LH	39101-6LB0A	1
SEAL – O-RING	31084-M750A	1
WASHER – SEAL	21626-32U00	1
GASKET – EXHAUST	20692-1HA0A	1
GASKET – EXHAUST	20691-30P0A	1
NISSAN LONG LIFE COOLANT BLUE (1)	999MP-L25500P	1
AT COOLER FLUSH 15 OZ (1)	999MP-AM006P	1
OIL ATF CVT 12 (1)	999MP-CV0NS3	1
GASKET – INTAKE MANIFOLD	14035-5TA0B	1
GASKET – INTAKE ADAPTER	16175-JA00A	1
SEAL – O-RING	92471-N823A	1
SEAL – O-RING	92472-N823A	1
CLAMP	16439-7S01E	2
CLAMP	21639-7990A	2
CIRCLIP – SIDE GEAR	38225-ET01C	2
NUT – LOCK, FRONT WHEEL BEARING	40262-4GA0D	2
NUT	01223-A0111	2
NUT	54588-JA060	2
NUT	01225-A0111	2
NUT – FIX, EXHAUST TUBE	20602-9U20B	2

- (1) Order this item through the Nissan Maintenance Advantage program: Phone 877-NIS-NMA1 (877-647-6621). Website order via link on the dealer portal; www.NNAnet.com and click on the “Maintenance Advantage-Tire/Battery/Chemical” link.

CLAIMS INFORMATION

Submit a "CM" line claim using the following claims coding:

CAMPAIGN ("CM") ID	DESCRIPTION	OP CODE		FRT
PMA37	Inspect Front LH Drive Shaft For Movement - OK	PMA370		0.4
	Inspect Front LH Drive Shaft For Movement, Replace CVT Assembly And Front LH Drive Shaft, And Fill and Adjust CVT Fluid Level	PMA371 (1)	Without AVM	10.0
		PMA372 (1)	With AVM	10.4

(1) VCAT approval required. Failure to obtain pre-approval prior to replacement may result in chargeback.

AMENDMENT HISTORY

PUBLISHED DATE	REFERENCE	DESCRIPTION
May 2, 2024	NTB24-024	Original bulletin published
May 6, 2024	NTB24-024A	CLAIMS INFORMATION revised, steps 16-18 added

