



GROUP	MODEL
Safety Recall Campaign	2023MY Niro EV (SG2 EV) 2024MY EV9 (MV)
NUMBER	DATE
SC308	May 2024

SAFETY RECALL CAMPAIGN

SUBJECT:

GEAR DRIVE UNIT REPLACEMENT (SC308)

This bulletin provides information to replace the front gear drive unit (GDU) on certain 2023MY Niro EV (SG2 EV) vehicles produced from November 7, 2022 through May 16, 2023 and the rear gear drive unit (GDU) on certain 2024MY EV9 (MV) vehicles produced from October 27, 2023 through December 14, 2023. The differential gear bolts within the subject vehicle's GDU may not have been properly torqued during the assembly by the differential gear supplier. Over time, the differential bolts within the GDU may loosen and damage the GDU housing and/or reduction gear while driving. Continued driving with a grinding noise from a damaged GDU housing or reduction gear may result in loss of motive power and/or cause the differential to lock up, increasing the risk of a crash. Follow the procedure outlined in this publication to replace the GDU on the applicable vehicle. Before conducting the procedure, verify that the vehicle is included in the list of affected VINs.

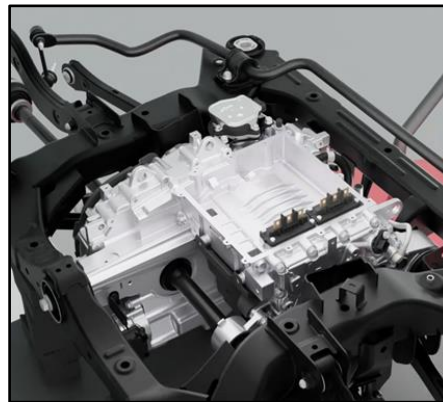
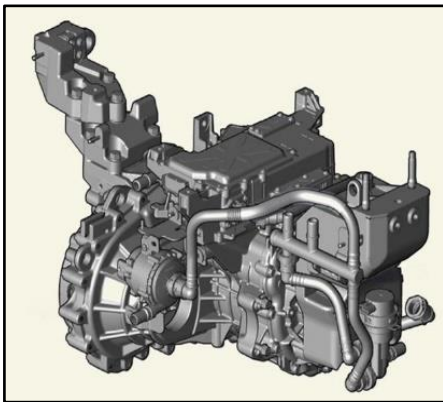

NOTICE

There is no charge to the vehicle owner for this repair. Under applicable law, you may not sell or otherwise deliver any affected vehicle until it has been repaired pursuant to the procedures set forth in this bulletin.

Repair status for a VIN is provided on KDealer+ (Service → Warranty Coverage → Warranty Coverage Inquiry → Campaign Information). Not completed Recall / Service Action reports are available on KDealer+ (Consumer Affairs → Not Completed Recall → Recall VIN → Select Report), which includes a list of affected vehicles.

A printed copy is for reference only; publication information can be updated at any time. Always refer to KGIS for the latest information. After logging in kdealer.com, the newest technical publications are listed in 'Service Releases' and has the latest service information that has been released.

Repair Procedure: Niro EV (SG2 EV)

1. Replace the Motor and Reduction Gear Assembly (A) by referring to "Motor and Reduction Gear System → Motor and Reduction Gear Assembly → Removal → Installation" in the applicable Shop Manual on KGIS.

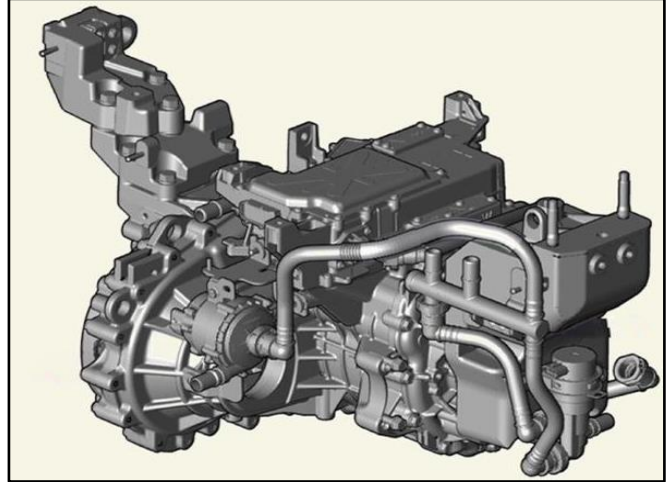

2. Reinstall all removed parts in reverse order of removal.
3. Confirm normal vehicle operation.

Repair Procedure: EV9 (MV)

1. Replace the Rear Motor and Reduction Gear Assembly (A) by referring to "Motor and Reduction Gear System → Rear Motor and Reduction Gear Assembly → Removal → Installation" in the applicable Shop Manual on KGIS.

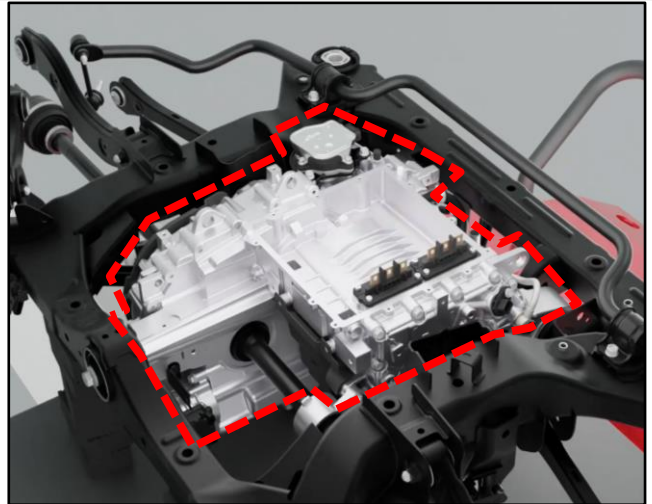



2. Reinstall all removed parts in reverse order of removal.
3. Confirm normal vehicle operation.

SUBJECT:

GEAR DRIVE UNIT REPLACEMENT (SC308)**AFFECTED VEHICLE RANGE:**

Model	Production Date Range
Niro EV (SG2 EV)	November 7, 2022 to May 16, 2023
EV9 (MV)	October 27, 2023 to December 14, 2023

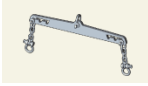
REQUIRED TOOL:

Tool Name	Part Number	Figure	Comments
Engine Support Fixture (adapter)	09200 4X000		N/A
CV Joint Puller	09517 4E000		Located in Toolbox 1 Drawer 11

REQUIRED PART:

Model	Part Name	Part Number	Figure	Qty.
Niro EV (SG2 EV)	Front Motor-Gear Drive Unit Assembly	36501 0EDA0QQK	N/A	1
	Lock Nut	55259 2M000		2
	Split Pin	57799 4D200		2
	Lock Nut	49551 3X000		2
	Clip	49557 F2000		2
	Bolt	56415 L1000		1
	Bolt	21920 A7000		1
	Bolt	55117 AA100		4
	Nut	54559 1F000		2
	Gasket	366G1 0EJA0		1
	Gasket	366G2 0EJA0		1
	Gasket	366G9 0EJA0		1
	Gear Oil	UM022 CH269		5qts
	Coolant	UM020 CH263		4 Gallons
EV9 (MV)	Rear Motor-Gear Drive Unit Assembly	44000 18MD0QQK	N/A	1
	Bolt	58161 1H000		4
	Gasket	366G2 1XHMO		1
	Gasket	366G1 1XHMO		1
	Gasket	366G9 1XHMO		1
	Lock nut	49551 4T000		2
	Clip	49557 D0000		1
	Gear Oil	UM022 CH269		5qts
	Coolant	UM020 CH263		2 Gallons

Note: The replacement QQK part numbers will require a VIN entry for parts ordering. DO NOT order these parts for stocking purposes, related to this Campaign. Supply is very limited. Until supply stabilizes, please confirm part availability before scheduling customers. Please be sure to expedite warranty claim filing.



SUBJECT: **GEAR DRIVE UNIT REPLACEMENT (SC308)**

WARRANTY INFORMATION:

N Code: N99 C Code: C99

Model	Claim Type	Causal P/N	Qty.	Repair Description	Labor Op Code	Op Time	Replacement P/N	Qty.
SG2 EV	R	36501 OEDAO	0	(SC308) Front Motor-Gear Drive Unit Replacement	241054R0	5.3 M/H	36501 OEDAOQQK	1
							55259 2M000	2
							57799 4D200	2
							49551 3X000	2
							49557 F2000	2
							56415 L1000	1
							21920 A7000	1
							55117 AA100	4
							54559 1F000	2
							366G1 OEJAO	1
							366G2 OEJAO	1
							366G9 OEJAO	1
							UM022 CH269	5
							UM020 CH263	4
MV		44000 18MDO	0	(SC308) Rear Motor-Gear Drive Unit Replacement	241054R1	6.3 M/H	44000 18MDOQQK	1
							58161 1H000	4
							366G2 1XHMO	1
							366G1 1XHMO	1
							366G9 1XHMO	1
							49551 4T000	2
							49557 DO000	1
							UM022 CH269	5
							UM020 CH263	2

Note: Refer to [Warranty Bulletin 2024-36](#) for claim submission procedures. Manually enter sublet code 'X2' for reimbursement of one roundtrip rideshare expense or up to three (3) days of rental expense, with supporting documentation.

NOTICE

VIN inquiry data for this repair is provided for tracking purposes only. Kia retailers should reference **SC308** when accessing the KDealer+ system.

