



**PREVOST**

# SAFETY RECALL

**SR24-13**

DATE :	May 2024	SECTION :	22 HVAC
SUBJECT:	<b>PREHEATER HYDRONIC L2 - REWORK CLEANING INSTRUCTIONS FOR THE PRECISE CO2 MEASUREMENT</b>		

First Release

mm-jj-aaaa

## APPLICATION

<b>NOTICE TO SERVICE CENTERS</b>	
<i>Verify vehicle eligibility by checking warranty bulletin status with <b>SAP</b> or via <b>ONLINE WARRANTY SYSTEM</b> available on Service / Warranty tab of PrevoSt website.</i>	
<b>Model</b>	<b>VIN</b>
X3-45 coaches Model Year: 2024	
H3-45 coaches Model Year: 2006	
H3-45 coaches Model Year: 2013	
H3-45 coaches Model Year: 2017	
H3-45 coaches Model Year: 2020	
H3-45 coaches Model Year: 2023	
H3-45 coaches Model Year: 2024	
H3-45 VIP motorhomes Model Year: 2010	

**This Safety Recall does not necessarily apply to all the above-mentioned vehicles. Some vehicles may also have been modified before delivery. The owners of the vehicles affected by this recall will be advised by a letter indicating the Vehicle Identification Number (VIN) of each vehicle concerned.**

## DESCRIPTION

### **For Canadian customers:**

On vehicles affected by this recall, Eberspächer will inspect all subject vehicles and, if required, clean the preheater's internal components, replace damaged components, and adequately adjust the air to fuel ratio per the supplier's instructions.

**The work will be performed by an authorized Eberspächer dealer.**

**Eberspächer rework cleaning instructions # 25.2486.95.2683.0A.**

*Meanwhile, the supplier's recommendation is to immediately stop using the preheaters (coolant heaters) until they are remedied.*

### **For US customers:**

On vehicles affected by this recall, Prevest will inspect all subject vehicles and, if required, clean the preheater's internal components, replace damaged components, and adequately adjust the air to fuel ratio per the supplier's instructions include with the bulletin.

**The work will be performed by Prevest.**

*Meanwhile, the supplier's recommendation is to immediately stop using the preheaters (coolant heaters) until they are remedied.*

## FOR US CUSTOMERS ONLY

### MATERIAL

Order parts that may be required:

Part No.	Description	Qty
870106	FUEL ATOMIZER NOZZLE	1
870101	IGNITION ELECTRODE, WITH CHECK GAUGE	1
870077	BURNER	1
870088	PUMP, 24V COMPLETE	1
870100	IGNITION SPARK GENERATOR, 24V, WITH CHECK GAUGE	1
870102	NOZZLE PRE-HEATER 24V	1
870139	ELECTRIC MOTOR, 24V, INCL. COUPLING	1
870260	CONTROLL UNIT	1

#### **NOTE**

*Material can be obtained through regular channels.*

### TOOLS

TPI 708 COMBUSTION EFFICIENCY ANALYZER WITH FLUE PROBE



## SAFETY PRECAUTIONS

- Eye protection should always be worn when working in a shop.
- Rules for Personal Protection Equipment should always be respected. Wear your PPE including but not limited to the following:



# Safety First!



## PROCEDURE



### DANGER

Park vehicle safely, apply parking brake, stop the engine. Prior to working on the vehicle, set the ignition switch to the OFF position and trip the main circuit breakers equipped with a trip button. On Commuter type vehicles, set the battery master switch (master cut-out) to the OFF position.

Lockout & Tag out (LOTO) must be performed during set-up, maintenance or repair activities. Refer to your local procedure for detailed information regarding the control of hazardous energy.

**PREHEATER LOCATION H3**

1. Remove the left rear fender.

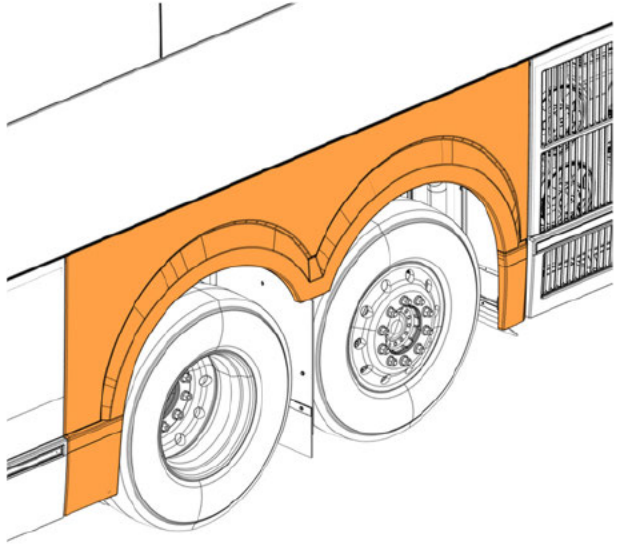

2. Locate the preheater.

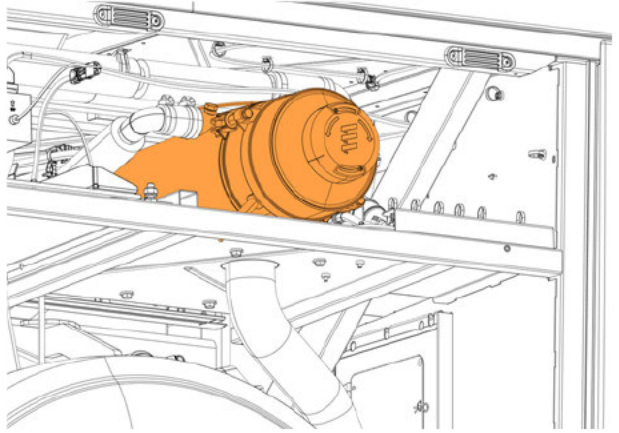

**PREHEATER LOCATION X3**

1. Open the left rear fender.

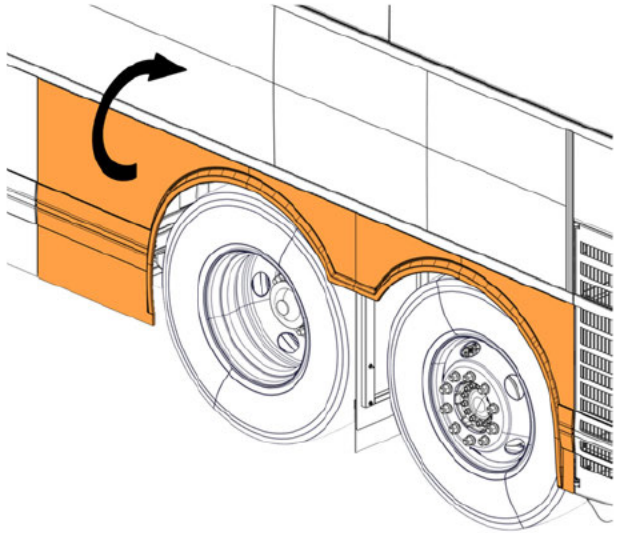

2. Locate the preheater.

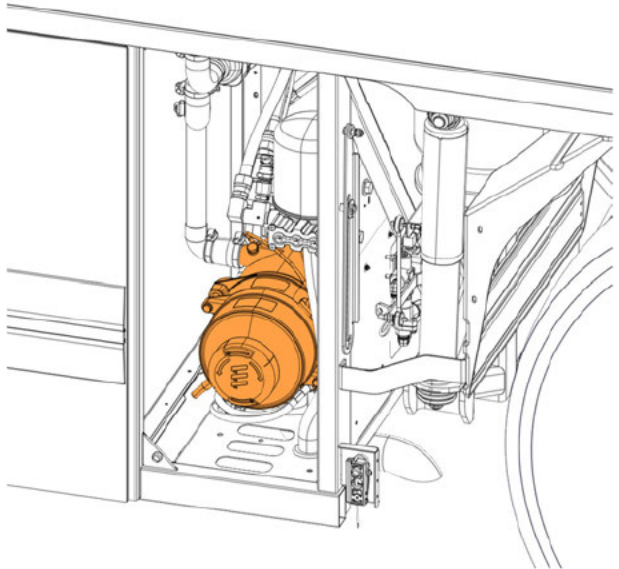

### PERFORM REWORK

- 1. See the Eberspächer rework cleaning instructions # 25.2486.95.2683.0A. at appendix A.

A WORLD OF COMFORT



EN / VEHICLE HEATERS / TECHNICAL DOCUMENTATION

## REWORK CLEANING INSTRUCTIONS FOR THE PRECISE CO<sub>2</sub> MEASUREMENT HYDRONIC L2

- 2. Before completing the bulletin, you must fill in the form inside the Eberspächer document and add the VIN.
- 3. Attach form to warranty email: [prevost.warranty@volvo.com](mailto:prevost.warranty@volvo.com), please make sure you have added the VIN.

#### 2 Confirmation form for rework action

**NOTE**  
The rework form must be completed for each reworked heater/turner

Customer \_\_\_\_\_

Installation Date \_\_\_\_\_

Rework Date \_\_\_\_\_

Heater Version \_\_\_\_\_

Material No. \_\_\_\_\_

Production date \_\_\_\_\_

Serial No. \_\_\_\_\_

CO<sub>2</sub> - value at first measurement \_\_\_\_\_

CO<sub>2</sub> - value after rework \_\_\_\_\_

Short description of performed work \_\_\_\_\_

\_\_\_\_\_

\_\_\_\_\_

## PARTS DISPOSITION

All replaced parts must be returned to Prevost according to the Return Shipping Instructions available on [www.prevostcar.com](http://www.prevostcar.com) (under service / warranty section) for full reimbursement. A copy of the warranty claim form must be enclosed with the shipment.

Discard waste according to applicable environmental regulations (Municipal/State[Prov.]/ Federal)

## WARRANTY

This modification is covered by Prevost's normal warranty. We will reimburse you the parts and 1 1/2 hour (1.5) of labor upon receipt of and a completed A.F.A. Please submit claim via our Online Warranty System, available at [www.prevostcar.com](http://www.prevostcar.com) (under service \ warranty section).

## OTHER

VBC Bulletin	N/A
Fail Code	22.09
Defect Code	09
Syst.Cond	R
Causal Part	870012

Access all our Service Bulletins on  
<http://techpub.prevostcar.com/en/>  
or scan the QR-Code with your smart phone.

E-mail us at [technicalpublications\\_prev@volvo.com](mailto:technicalpublications_prev@volvo.com) and type "ADD" in the subject to receive our warranty bulletins by e-mail.



# Appendix A

Eberspächer rework cleaning  
instructions #  
25.2486.95.2683.0A





EN / VEHICLE HEATERS / TECHNICAL DOCUMENTATION

# REWORK CLEANING INSTRUCTIONS FOR THE PRECISE CO<sub>2</sub> MEASUREMENT HYDRONIC L2

Engine-independent water heater for diesel fuel

**Designation**

Hydronic L16  
Hydronic L24  
Hydronic L30  
Hydronic L35

**Order No.**

25.2486.02.0000  
25.2487.02.0000  
25.2599.02.0000  
25.2600.02.0000

**Order No. - compact version**

---  
25.2487.05.0000  
25.2599.05.0000  
25.2600.05.0000

# 1 REWORK INSTRUCTION

1.1	Rework steps	2
1.1.1	CO <sub>2</sub> Measurement	2
1.1.2	Options how to proceed	3
1.1.3	Dismantling the heater	3
1.1.4	Dry-clean the components	3
1.1.5	Assembling the heater	4
1.1.6	Air flap in centre position	4
1.1.7	Adjusting the air flap	4

## 1 Rework instruction

- The following steps have to be carried out to clean the Hydronic L2 heater properly and to set the CO<sub>2</sub> measurement value.
- These Hydronic L2 heaters and Hydronic L2 burners are affected: Parts produced as of May 1st 2023 until January 31th 2024.
- All documents needed are attached to the heater or are available online at:  
<https://partner.eberspaecher.com/de>

### **i** NOTE

Please record your rework action in this document on page 5 and send it to Eberspächer to have your costs reimbursed.

## 1.1 Rework steps

### 1.1.1 CO<sub>2</sub> Measurement

- > Measure and determine the current CO<sub>2</sub> value during the operation of the heater.
- > Use a suitable CO<sub>2</sub> measuring device, e. g: MSI 150 Euro flue gas analyser 5600593
- > Connect the CO<sub>2</sub> measuring device to the exhaust system of the heater.
- > Wait about 60 seconds after starting the heater, until the combustion runs stable, or longer, depending on the ambient conditions (until you hear a stable and even combustion!).

### **!** CAUTION!

#### RISK OF POISONING

- Do not operate the heater longer than necessary.
- Switch off the heater after you have measured a reliable CO<sub>2</sub> value.

### **i** NOTE

- You will find the CO<sub>2</sub> specification in the Technical Description of the heater.
- The Technical Description of the heater
  - is attached to the product
  - is available online at:  
<https://partner.eberspaecher.com>



### 1.1.2 Options how to proceed

- The CO<sub>2</sub> value is within the tolerance.  
→ No further step is necessary.
- The CO<sub>2</sub> value is outside the tolerance, but the heater was not in operation (with combustion).  
→ Continue with chapt. 1.1.6.
- The CO<sub>2</sub> value is outside the tolerance and the heater has been in operation (with combustion)  
→ Carry out chapt. 1.1.3 to chapt. 1.1.7

### 1.1.3 Dismantling the heater

- > Remove the hood, the burner and the combustion chamber from the heat exchanger.
- > In doing so, please consult and follow the disassembly steps in the Troubleshooting and Repair Instructions of the Hydronic L2 heater.

#### **i** NOTE

You will find the Troubleshooting and Repair Instructions of the Hydronic L2 heater online at: <https://partner.eberspaecher.com>



### 1.1.4 Dry-clean the components

- > Dry-clean all components contaminated with black soot (burner, hood, combustion chamber, heat exchanger).
- > Use a cleaning cloth and a suitable wire brush.
- > Soot particles can be sucked out of the heat exchanger with a dust extractor.

#### **i** NOTE

- Please consider the local regulations regarding dust classes.
  - If the fuel nozzle is affected with residues, it must be replaced.
- See troubleshooting and repair instructions.

#### **!** CAUTION!

##### RISK OF DAMAGED SURFACES

- Do not damage the surfaces of the heat exchanger.
- Use a wire brush only.
- Do not use liquid cleaners, e. g. brake cleaner.

##### RISK OF DAMAGED COMPONENTS

- When cleaning the burner, always pay attention to sensitive components, e. g. plug- and-socket connections.

##### RISK OF FUEL BLOCKAGE

- The fuel nozzle is a very sensitive component. Do not touch it under any circumstances.
- If the fuel nozzle is dirty, it must be replaced (see Repair Instructions).

- > See example pictures below for cleaning the combustion chamber and the heat exchanger:



Combustion chamber before ... and after cleaning.

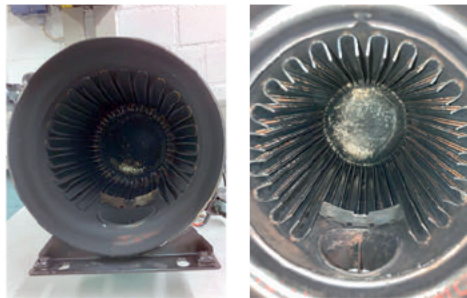

Heat exchanger before ... and after cleaning.

### 1.1.5 Assembling the heater

- > Assemble the heater as described in the Troubleshooting and Repair Instructions.

### 1.1.6 Air flap in centre position

- > Loosen the two screws on the air adjustment flap and roughly adjust as shown in the picture on the right (medium setting of the flap).
- > This prevents further coarse soot formation during fine adjustment.



### 1.1.7 Adjusting the air flap

- > Allow the heater to warm up and measure the CO<sub>2</sub> values by using a suitable CO<sub>2</sub> measuring device.
- > Set the correct CO<sub>2</sub> value by turning the air adjustment flap.

#### **i** NOTE

- Turn the air adjustment flap
  - to the left: increase of the CO<sub>2</sub> value.
  - to the right: decrease the CO<sub>2</sub> value.
- In order to obtain a valid result, wait approx. 100 s after each small adjustment of the air flap until the actual CO<sub>2</sub> value is displayed.

- > When the correct CO<sub>2</sub> value is reached,
  - turn off the heater.
  - tighten the screws of the air flap.

## 2 Confirmation form for rework action

### NOTE

The rework form must be completed for each reworked heater/burner

Customer \_\_\_\_\_

Installation Date \_\_\_\_\_

Rework Date \_\_\_\_\_

Heater Version \_\_\_\_\_

Material No. \_\_\_\_\_

Production date \_\_\_\_\_

Serial No. \_\_\_\_\_

CO<sub>2</sub> - value at first measurement \_\_\_\_\_

CO<sub>2</sub> - value after rework \_\_\_\_\_

Short description of performed work

---



---



---



---



---



---



---



---

The rework will be reimbursed by Eberspächer Climate Control Systems as follows:

- CO<sub>2</sub> on heater or on burner **must be adjusted** (heater was not in operation)  
→ 5AW = 30 minutes
- CO<sub>2</sub> on heater or on burner **must be adjusted** (heater has been in operation)  
Heater **must be cleaned**  
→ 15AW = 90 minutes

Please send this completed form and the invoice including the labour costs to the following invoice address with reference

**HL-II CO<sub>2</sub> adjustment rework to:**  
[CC-Warranty-Service@eberspaecher.com](mailto:CC-Warranty-Service@eberspaecher.com)  
[PL-0L-faktury@eberspaecher.com](mailto:PL-0L-faktury@eberspaecher.com)

**Invoice recipient**, stated on the invoice:  
 Eberspächer Climate Control Systems Sp. z o.o.  
 Climate Control Systems  
 Godzikowice 50 P  
 55- 200 Olawa  
 Polska





Eberspächer Climate Control  
Systems International GmbH  
Eberspächerstraße 24  
73730 Esslingen  
Germany  
[info@eberspaecher.com](mailto:info@eberspaecher.com)  
[www.eberspaecher.com](http://www.eberspaecher.com)