

SAFETY RECALL
 NORTH AMERICA
SCCM Internal Failure



Reference: 35B / NHTSA 24V-199

FCA US LLC



Remedy available for
 2023-2024 (RU) Chrysler Pacifica and
 Voyager

Template Version 1.0

Revision	Edition	Detail
0	May 2024	Initial Version.

SYMPTOM DESCRIPTION

About 3,280 of the above vehicles may have been built have been built with a steering column control module (SCCM) with an insufficient weld between an internal flexible flat cable (FFC) and busbar. The SCCM may not allow a deployment signal from the Occupant Restraint Controller to reach the driver airbag module, preventing airbag deployment. An airbag that does not deploy when intended may result in increased risk of injury to the driver in a crash.

The condition described above does not comply with Federal Motor Vehicle Safety Standard (FMVSS) No. 208 which requires driver's airbag deployment during certain crash events. The SCCM in the suspect vehicles may not allow a deployment signal from the Occupant Restraint Controller to reach the driver airbag module, preventing airbag deployment during these events.

SCOPE

This recall applies only to the above vehicles.

NOTE: Some vehicles above may have been identified as not involved in this recall and therefore have been excluded from this recall.

IMPORTANT:

- Some of the involved vehicles may be in dealer new vehicle inventory. Federal law requires you to complete this recall service on these vehicles before retail delivery. Violation of this requirement by a dealer could result in a civil penalty of up to \$27,168 per vehicle.
- Some of the involved vehicles may be in dealer used vehicle inventory. Dealers should complete this recall service on these vehicles before retail delivery.
- Dealers should also perform this recall on vehicles in for service.

Involved vehicles can be determined by using the VIP inquiry process.

REPAIR TO BE PERFORMED

Verify the SCCM Julian date using wiTech. If the SCCM falls within the provided date range, replace the SCCM. If it does not fall within the provided date range, return the vehicle to the customer.

COMPLETION REPORTING / REIMBURSEMENT

Claims for vehicles that have been serviced must be submitted on the DealerCONNECT Claim Entry Screen located on the Service tab. Claims paid will be used by FCA to record recall service completions and provide dealer payments.

Use the following labor operation numbers and time allowances:

Labor Description	Number	Hrs
Inspect Steering Column Control Module SCCM	08-35-B1-81	0.2
Inspect and Replace Steering Column Control Module SCCM	08-35-B1-82	0.6
Inspect and Replace Steering Column Control Module SCCM - PHEV Models Only	08-35-B1-83	1.2

Labor Description	Number	Allowance
Floor Plan Reimbursement	95-95-95-97	Calculate See Below

Floor Plan Reimbursement represents the vehicle's average daily allowance (see table below) multiplied by the number of days the vehicle was in dealer inventory and not available for sale. This reimbursement is limited to the number of days from the date of the stop sale to the date that the remedy was made available. Note: If the vehicle was received by your dealership (KZX date) AFTER the stop sale

date, you will use the KZX date instead of the stop sale date. For this Recall, the stop sale was initiated on **03/21/2024** and the remedy was made available on **05/21/2024**, therefore, the number of days cannot exceed **61** days.

Vehicle	Average Daily Allowance
2023-2024 (RU) Chrysler Pacifica and Voyager	██████

NOTE: See the Warranty Administration Manual, Recall Claim Processing Section, for complete recall claim processing instructions.

PARTS INFORMATION

Part No.	Qty.	Part Name
CSAR35B1AA	1	MULTIFUNCTION (SWITCH)
CSBR33B3AA	1	HEX LOCK (M16X1.50)

PARTS RETURN

No parts return required for this campaign.

Render the recalled part unusable and discard.

SPECIAL TOOLS

Number	Description
NPN	wiTECH MicroPod II / MDP
NPN	Laptop Computer
NPN	wiTECH Software
C-4755	Trim Stick
2050200100	Remover, Driver Air Bag

DEALER NOTIFICATION

To view this notification on DealerCONNECT, select “Global Recall System” on the Service tab, then click on the description of this notification.

OWNER NOTIFICATION / SERVICE SCHEDULING

All involved vehicle owners known to FCA are being notified of the service requirement by first class mail. They are requested to schedule appointments for this service with their dealers. A generic copy of the owner letter is attached.

VEHICLE LISTS, GLOBAL RECALL SYSTEM, VIP AND DEALER FOLLOW UP

All involved vehicles have been entered into the DealerCONNECT Global Recall System (GRS) and Vehicle Information Plus (VIP) for dealer inquiry as needed.

GRS provides involved dealers with an updated VIN list of their incomplete vehicles. The owner’s name, address and phone number are listed if known. Completed vehicles are removed from GRS within several days of repair claim submission.

To use this system, click on the “**Service**” tab and then click on “**Global Recall System.**” Your dealer’s VIN list for each recall displayed can be sorted by: those vehicles that were unsold at recall launch, those with a phone number, city, zip code, or VIN sequence.

Dealers must perform this repair on all unsold vehicles before retail delivery. Dealers should also use the VIN list to follow up with all owners to schedule appointments for this repair.

Recall VIN lists may contain confidential, restricted owner name and address information that was obtained from the Department of Motor Vehicles of various states. Use of this information is permitted for this recall only and is strictly prohibited from all other use.

ADDITIONAL INFORMATION

If you have any questions or need assistance in completing this action, please contact your Service and Parts District Manager.

Customer Services / Field Operations
FCA US LLC.

SERVICE PROCEDURE - DIAGNOSIS

A. wiTECH Diagnostic Testing

NOTE: The wiTECH scan tool must be used to perform this recall. The wiTECH software is required to be at the latest release level before performing this procedure.

1. Connect the wiTECH MDP to the vehicle data link connector.
2. Place the ignition in the **“RUN”** position.
3. Open the wiTECH 2.0 website.
4. Enter your **“User id”** and **“Password”** and your **“Dealer Code”**, then select **“Sign In”** at the bottom of the screen. Click **“Accept”**.
5. From the **“Vehicle Selection”** screen, select the vehicle to be updated.
6. Select **“SCCM”** from the topology screen.
7. Go to the **“Misc. Functions”** tab.
8. Select **“SCCM Serial Number Validation”**.
9. One of these results will be displayed:
 - **“Serial Number Confirmed OK. No replacement needed.”** Clear any set codes and return the vehicles to the owner.
 - **“This SCCM is faulty and needs replacement. Refer to recall instructions.”** Complete the SCCM replacement steps below.

SERVICE PROCEDURE

B. Remove SCCM

WARNING: Part of this recall population contains hybrid vehicles. Follow all safety precautions published in Service Library for the specific vehicle you are working on.

WARNING: To avoid serious or fatal injury on vehicles equipped with airbags, disable the Supplemental Restraint System (SRS) before attempting any steering wheel, steering column, airbags, airbag curtains, knee blocker, seat belt tensioner, impact sensor or instrument panel component diagnosis or service. Disconnect the Intelligent Battery Sensor (IBS)/negative battery cable assembly from the negative battery post, then wait two minutes for the system capacitor to discharge before performing further diagnosis or service. This is the only sure way to disable the SRS. Failure to take the proper precautions could result in accidental airbag deployment.

CAUTION: Always turn the steering wheel until the front wheels are in the straight-ahead position. Then, prior to disconnecting the steering column from the steering gear, lock the steering wheel to the steering column. If clockspring centering has been compromised for ANY reason, the entire Steering Column Control Module (SCCM) and clockspring unit **MUST** be replaced with a new unit.

1. Place the front wheels in the straight-ahead position and inhibit the steering column shaft from rotation.
2. Extend the steering column to the fully extended position and lower it to its lowest (down) position.
3. Disconnect and isolate the negative battery cable. If equipped with an Intelligent Battery Sensor (IBS), disconnect the IBS connector first before disconnecting the negative battery cable. Wait two minutes for the system capacitor to discharge before further service.
4. Remove the steering wheel (Refer to 19 - Steering/Column/WHEEL, Steering/Removal and Installation).

SAFETY RECALL
NORTH AMERICA
SCCM Internal Failure



Reference: 35B / NHTSA 24V-199

FCA US LLC

5. Remove the outer shroud from the steering column (Refer to 19 - Steering/Column/SHROUD, Steering Column/Removal and Installation).
6. Remove the four screws (3) from the SCCM (Figure 1).
7. Release the four integral retainers (2) for the lower shroud and push the lower shroud toward the instrument panel as far as it will go.

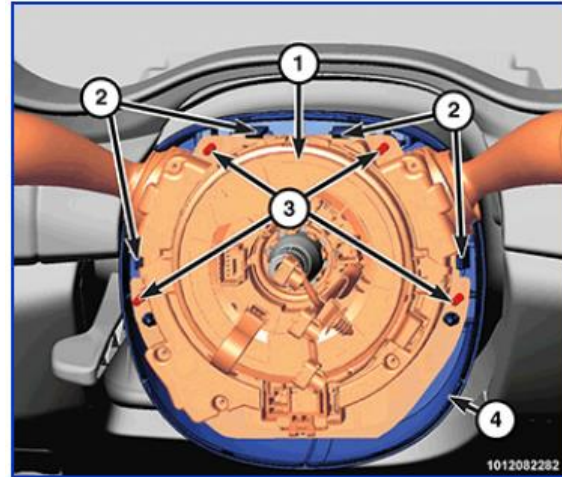

- 1 - SCCM
- 2 - Integral Retainers
- 3 - Screws
- 4 - Lower Shroud

Figure 1 – SCCM Fasteners

SAFETY RECALL
NORTH AMERICA
SCCM Internal Failure



Reference: 35B / NHTSA 24V-199

FCA US LLC

8. Loosen the centering attachment fastener (1) on the top, rear of the SCCM. Do not remove the fastener completely (Figure 2).
9. Loosen the clamp fastener (2) to allow the SCCM to be removed. Do not remove the fastener completely (Figure 2).

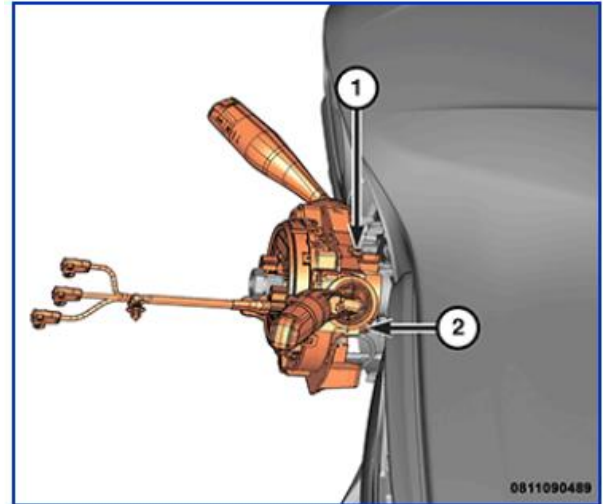

- 1 - Attachment Screw
- 2 - Clamp Screw

Figure 2 – SCCM Fasteners

10. Pull the SCCM (2) away from the steering column lower shroud (1) far enough to disconnect the instrument panel wiring harness connectors (3) (Figure 3).
11. Disconnect the two instrument panel wire harness connectors (3) from the SCCM (2) (Figure 3).
12. Remove the SCCM (2) from the steering column (Figure 3).

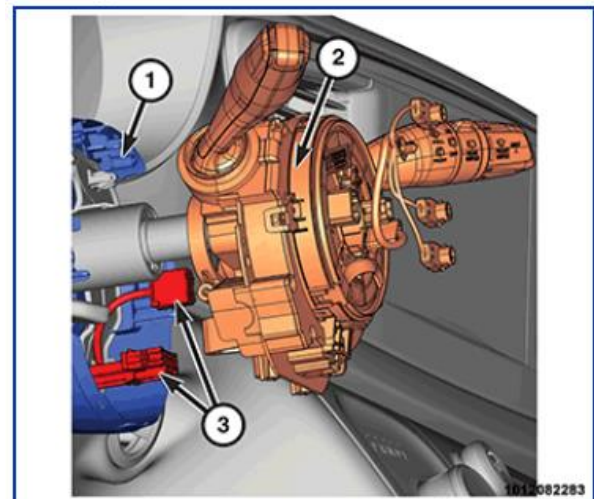

- 1 - Lower Shroud
- 2 - SCCM
- 3 - Wire Harness Connectors

Figure 3 – SCCM Removal

SERVICE PROCEDURE

C. Install SCCM

WARNING: To avoid serious or fatal injury on vehicles equipped with airbags, disable the Supplemental Restraint System (SRS) before attempting any steering wheel, steering column, airbags, airbag curtains, knee blocker, seat belt tensioner, impact sensor or instrument panel component diagnosis or service. Disconnect the Intelligent Battery Sensor (IBS)/negative battery cable assembly from the negative battery post, then wait two minutes for the system capacitor to discharge before performing further diagnosis or service. This is the only sure way to disable the SRS. Failure to take the proper precautions could result in accidental airbag deployment.

CAUTION: Always turn the steering wheel until the front wheels are in the straight-ahead position. Then, prior to disconnecting the steering column from the steering gear, lock the steering wheel to the steering column. If clockspring centering has been compromised for ANY reason, the entire Steering Column Control Module (SCCM) and clockspring unit **MUST** be replaced with a new unit.

Follow the removal procedure in reverse for general reassembly of the components on the vehicle. The steps listed below are calling out specific procedures that should be followed during installation.

- A service replacement SCCM is shipped with the clockspring centered and with a molded plastic lock installed. This lock should not be broken off until the SCCM has been installed on the steering column.
- Align the SCCM to allow the locating screw to be installed into the steering column on the top, rear of the SCCM.
- Install the centering attachment screw. Tighten the screw securely.
- Tighten the clamp screw securely to prevent the SCCM from moving.
- Be certain all four integral lower shroud retainers are engaged with the SCCM.
- If a new SCCM is being installed, break off the plastic lock (1) that secures the clockspring rotor to the SCCM housing to maintain clockspring centering. Rotate the lock towards the center (2) of the SCCM to break it off in the SCCM housing (Figure 4).

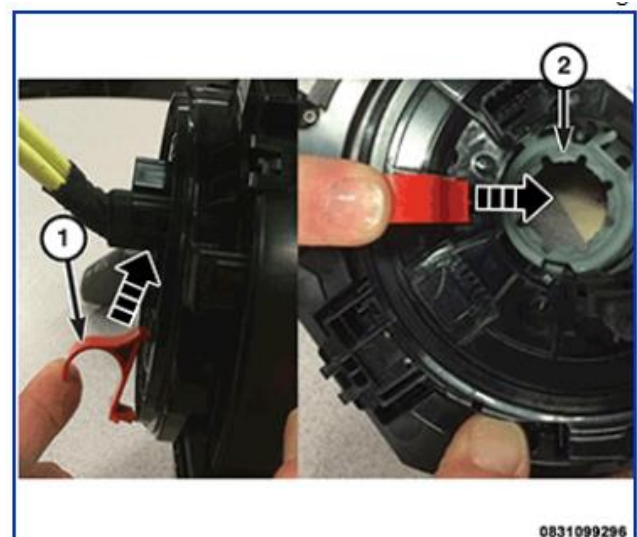

- 1 - Plastic Lock
- 2 - Clockspring Rotor

Figure 4 – Clockspring Lock

- When the lock (1) has been broken off properly, it should have one leg longer (2) than the other when viewed from the side (Figure 5).

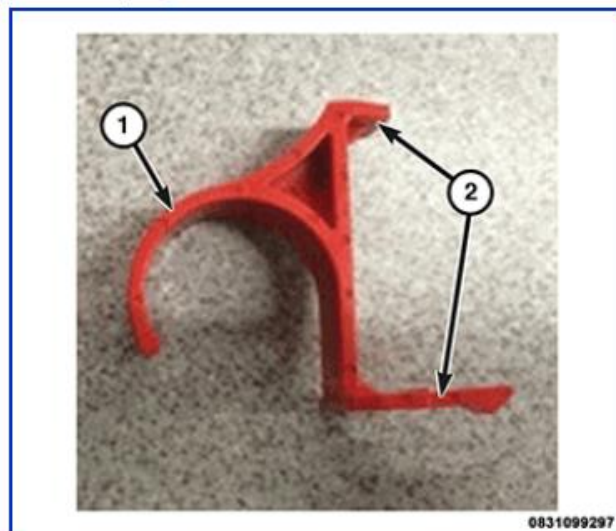

1 - Lock
2 - Leg

Figure 5 – Clockspring Lock

This notice applies to your vehicle,

[Model Year and Model]

VIN XXXXXXXXXXXXXXXXXXXX

35B/NHTSA 24V-199

LOGO

VEHICLE PICTURE

YOUR SCHEDULING OPTIONS

1. RECOMMENDED OPTION

Call your authorized Chrysler / Dodge / Jeep® / RAM / Dealership.

2. Call the FCA Recall Assistance

Center at **1-800-853-1403**. An agent can confirm part availability and help schedule an appointment.

3. Visit recalls.mopar.com, scan the

QR code below, or download the Mopar Owner’s Companion App.

QR Code

Get access to recall notifications, locate your nearest dealer, and more through this website or Mopar Owner’s Companion App. You will be asked to provide your Vehicle Identification Number (VIN) to protect and verify your identity. The last eight characters of your VIN are provided above.

DEALERSHIP INSTRUCTIONS

Please reference Safety Recall 35B.

IMPORTANT SAFETY RECALL

SCCM Internal Failure

Dear [Name],

This notice is sent to you in accordance with the National Traffic and Motor Vehicle Safety Act.

FCA US LLC has decided that certain [2023 Model Year (RU) Chrysler Voyager and 2023 and 2024 Model Year (RU) Chrysler Pacifica] vehicles fail to conform to Federal Motor Vehicle Safety Standard (FMVSS) No. 208 – Occupant Crash Protection.

It is extremely important to take steps now to repair your vehicle to ensure the safety of you and your passengers.

WHY DOES MY VEHICLE NEED REPAIRS?

The Steering Column Control Module (SCCM) on your vehicle ^[1] may have been built with an insufficient weld between an internal flexible flat cable (FFC) and busbar. The SCCM may not allow a deployment signal from the Occupant Restraint Controller to reach the driver airbag module, preventing airbag deployment. **An airbag that does not deploy when intended may result in increased risk of injury to the driver in a crash.**

Federal Motor Vehicle Safety Standard (FMVSS) No. 571.208 requires driver’s airbag deployment during certain crash events.

HOW DO I RESOLVE THIS IMPORTANT SAFETY ISSUE?

FCA US LLC will repair your vehicle ^[2] free of charge (parts and labor). To do this, your dealer will inspect and, if necessary, replace the steering column control module. The estimated repair time is one hour. In addition, your dealer will require your vehicle for proper check-in, preparation, and check-out during your visit, which may require more time.

Please schedule a service appointment on or after May 21st, 2024, as the remedy will not be available before then.

Please bring this letter with you to your dealership.

**TO SCHEDULE YOUR FREE REPAIR,
CALL YOUR CHRYSLER, DODGE, JEEP OR RAM DEALER TODAY**

WHAT IF I ALREADY PAID TO HAVE THIS REPAIR COMPLETED?

If you have already experienced this specific condition and have paid to have it repaired, you may visit www.fcarecallreimbursement.com to submit your reimbursement request online. ^[3] Once we receive and verify the required documents, reimbursement will be sent to you within 60 days. If you have had previous repairs performed and/or already received reimbursement, you may still need to have the recall repair performed.

We apologize for any inconvenience, but are sincerely concerned about your safety. Thank you for your attention to this important matter.

Customer Assistance/Field Operations
FCA US LLC



Mr. Mrs. Customer
1234 Main Street
Hometown, MI 48371

[1] If you no longer own this vehicle, please help us update our records. Call the FCA Recall Assistance Center at 1-800-853-1403 to update your information.

[2] If your dealer fails or is unable to remedy this defect without charge and within a reasonable time, you may submit a written complaint to the Administrator, National Highway Traffic Safety Administration, 1200 New Jersey Ave., S.E., Washington, DC 20590, or you can call the toll-free Vehicle Safety Hotline at 1-888-327-4236 (TTY 1-800-424-9153), or go to safercar.gov.

[3] You can also mail in your original receipts and proof of payment to the following address for reimbursement consideration: FCA Customer Assistance, P.O. Box 21-8004, Auburn Hills, MI 48321-8007, Attention: Recall Reimbursement.

Note to lessors receiving this recall notice: Federal regulation requires that you forward this recall notice to the lessee within 10 days.