



# Campaign Service

## BULLETIN

### IMPORTANT SERVICE INFORMATION FOR:

- ✓ SERVICE MANAGER
- ✓ SERVICE ADVISOR
- ✓ TECHNICIAN
- ✓ PARTS DEPARTMENT
- ✓ WARRANTY PERSONNEL

**BULLETIN NUMBER:**  
CB24-R-001B

**ISSUE DATE:**  
MARCH 2024

**GROUP:**  
ACCESSORIES

## IMPORTANT SAFETY RECALL

### F-SERIES MOBILEYE CAMERA CABLE ROUTING – 24V-157

(Transport Canada 2024-134)



CV

#### AFFECTED VEHICLES

- 2019-2024MY F-Series Vehicles  
Equipped with RPO Code I4V Mobileye Collision Warning System

*This bulletin supersedes previous campaign bulletin CB24-R-001A. This bulletin is being updated to update text in Figure 25 and Step 74. Please discard previous campaign bulletin CB24-R-001A.*

#### INFORMATION

##### CONDITION

Isuzu Motors Limited has decided that a defect, which relates to motor vehicle safety, exists in certain 2019-2024MY F-Series vehicles equipped with RPO Code I4V Mobileye Collision Warning System. In the affected vehicles, the wiring for the Mobileye camera may have been routed incorrectly. As a result, the wiring could become damaged by contact with dash components and could overheat and melt. If this happens, the turn signals and hazard lights may not work properly, and the Mobileye collision avoidance information would not be displayed, increasing the **risk of a crash**. In addition, wiring that overheats and melts increases the **risk of a fire**.

##### CORRECTION

Isuzu dealers will inspect the wiring for the damaged condition. If no problem is found, the wiring will be rerouted to remove the risk of future damage. If the wiring is damaged, it will be replaced and routed to remove the risk of future damage. This service will be performed **free of charge**.

## VEHICLES INVOLVED

Involved are certain 2019-2024MY F-Series vehicles equipped with RPO Code I4V Mobileye Collision Warning System.

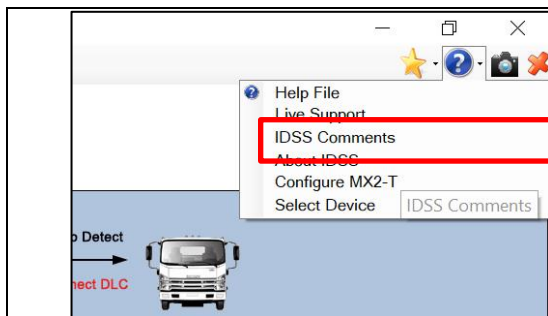
**NOTE:** It is NOT necessary to open a TAC case or generate a health report in order to submit a warranty claim for this campaign.

**IMPORTANT: Dealers are to confirm vehicle eligibility prior to beginning repairs by using IVIS (Isuzu Vehicle Information System).**

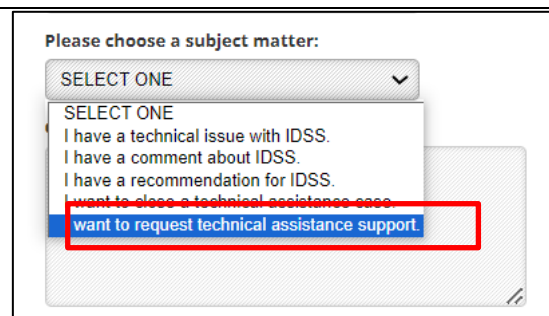
## PARTS INFORMATION

If the Inspection Procedure below directs the technician to replace parts, per Step 1.a., 7.a., or 15.a., follow the steps in this Parts Information section to request replacement parts.

To request parts, use the “IDSS Comments” function in IDSS. (See Figure 1.) After clicking on “IDSS comments”, select “I want to request technical assistance support” from the “Please choose a subject matter” dropdown menu. (See Figure 2.)



**Figure 1**

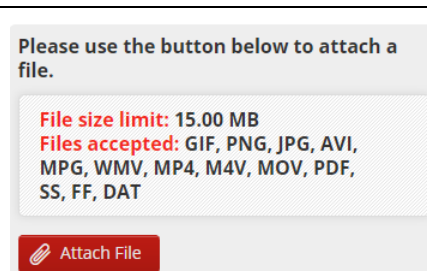


**Figure 2**

Enter your contact information and vehicle information. Enter the inspection step number which determined the harness was damaged and a brief explanation of the damage into the “questions/comments” field. (See Figure 3.) Also, if there are any special shipping instructions, (i.e. address change or attention person) please also add this information. Attach a photo of the damaged harness taken in Step 15.a., if applicable. (See Figure 4.)



**Figure 3**



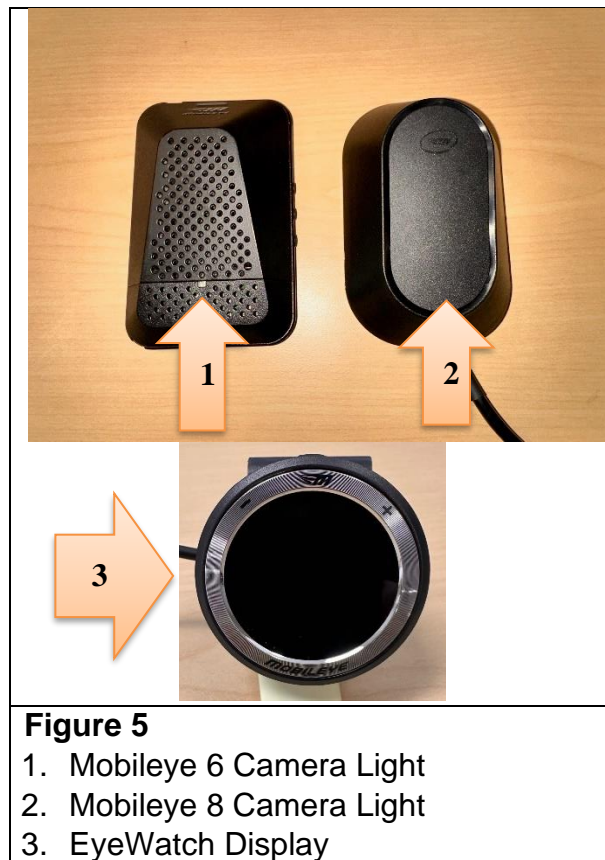
**Figure 4**

Click the “Submit” button. The information provided will be sent to the Isuzu Technical Assistance Center. Based on the information provided parts will be shipped as soon as possible and free of charge.

Once campaign remedy parts are received, follow the “New Harness Installation Procedure” below. Go to Step 45 in this bulletin.

## INSPECTION PROCEDURE

1. With the Engine Control Switch turned to the “ON” position, engine “OFF”, move the turn signal lever to the left turn or right turn position and confirm that each indicator on the instrument panel cluster operates properly. Confirm that the light on the Mobileye camera is on and no codes are present in the EyeWatch display. (See Figure 5.)



- a. If one or both of the turn signal indicators do not function properly (e.g. both indicators flash simultaneously), the camera cable must be replaced. Refer to the Parts Information section above for more information.
  - b. If no problem was found, continue to the next step.
2. Turn the Engine Control Switch to the “Lock” position, wait at least three minutes and then disconnect the negative battery cable.

**IMPORTANT: The ECM may malfunction if the battery is disconnected within 3 minutes of turning the Engine Control Switch off.**

3. Remove the meter cluster bezel from the instrument panel by pulling forward and disconnecting the switches. (See Figure 6.)



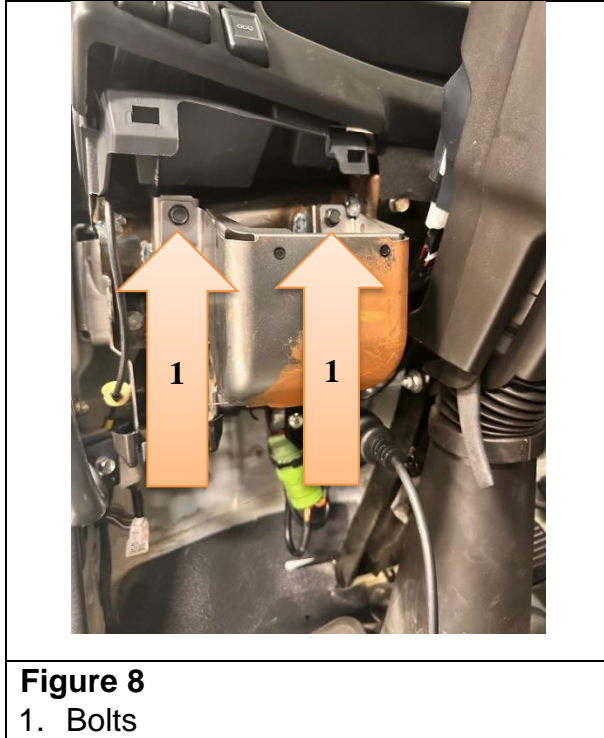
**Figure 6**

4. Remove the driver side instrument side cover. (See Figure 7.)

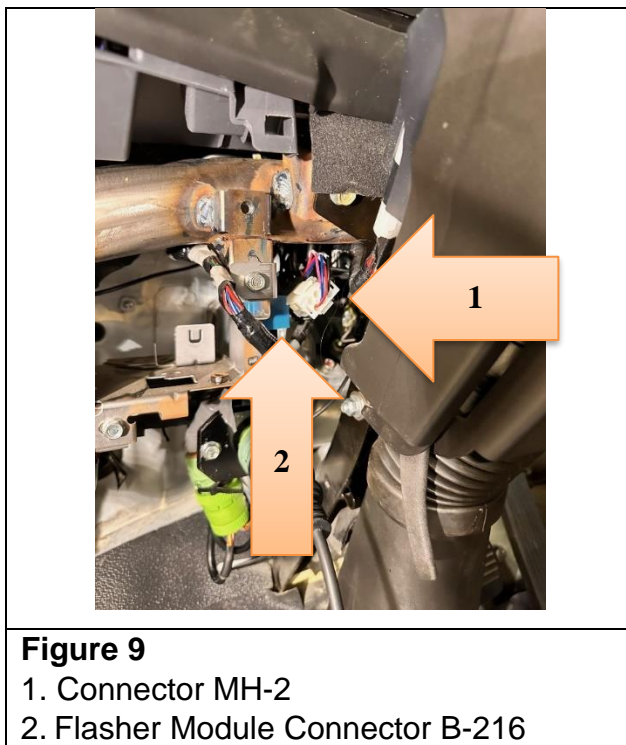


**Figure 7**

5. Remove the two (2) 10mm bolts and remove the knee bracket. (See Figure 8.)

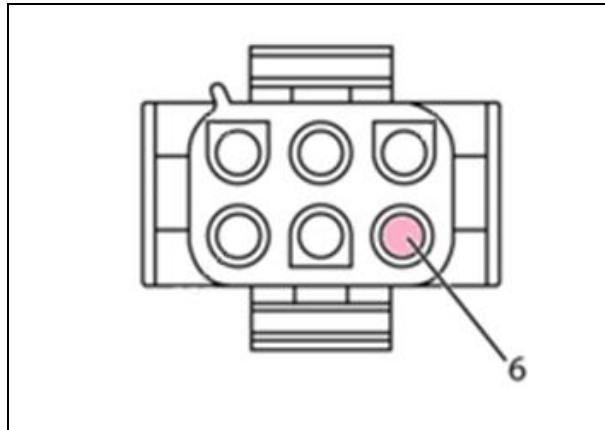


6. Disconnect connector MH-2 located near and slightly above the B-216 Flasher Module. (See Figure 9.)



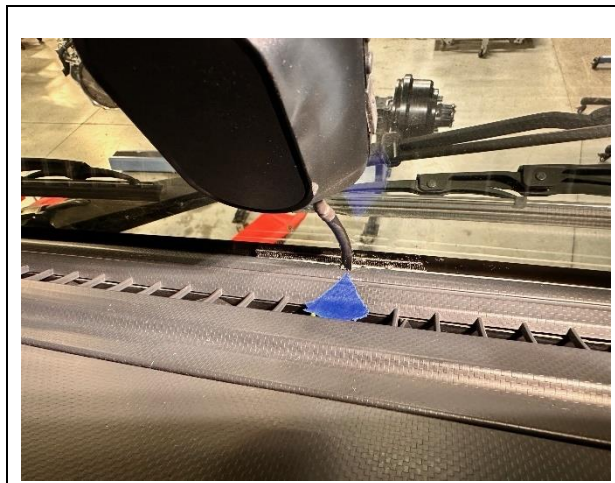
7. Using an ohm meter, test for continuity between the male end of connector MH-2 Pin 6 (pink wire) and body ground. (See Figure 10.)

- a. If the wire has continuity to ground, the camera cable must be replaced. See the Parts Information section above for more information.
- b. If the wire has no continuity to ground, reconnect connector MH-2 and go to Step 8.



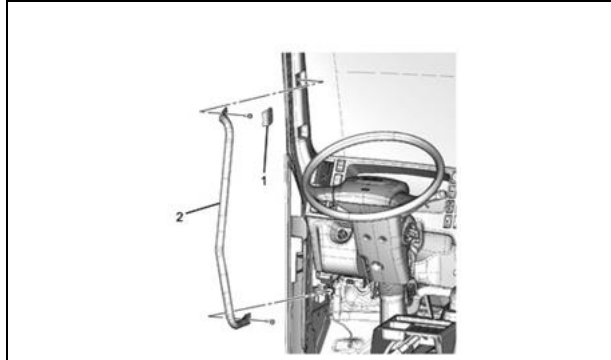
**Figure 10**  
1. Pin 6 of Connector MH-2

8. Using one (1) inch of masking tape, mark the location near the center of the instrument panel where the Mobileye camera cable goes under the instrument panel. (See Figure 11.)



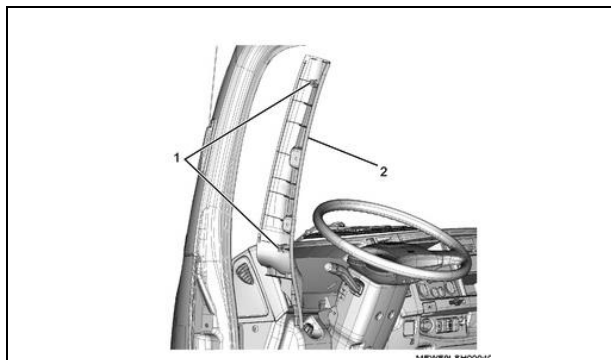
**Figure 11**  
Tape location

9. Open the assist handle upper cover using a flathead screwdriver and remove the upper bolt. Then remove the lower bolt of the assist handle and remove the assist handle from the front pillar. (See Figure 12.)



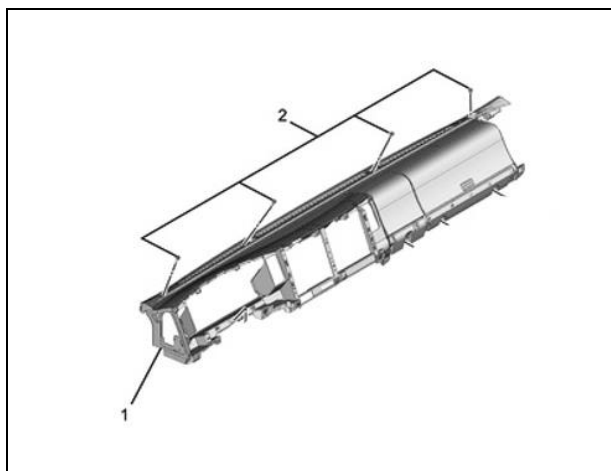
**Figure 12**  
2. Assist Handle

10. Pull the front door weatherstrip away from the front pillar trim cover. Then pull the front pillar trim cover up and remove it from the front pillar. (See Figure 13.)



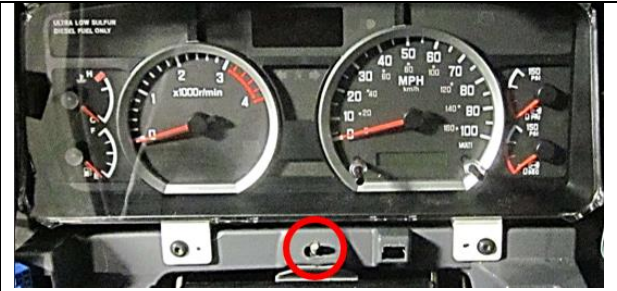
**Figure 13**  
2. Front Pillar Trim Cover

11. Remove the four (4) instrument panel (IP) mounting bolts. (See Figure 14.)



**Figure 14**  
1. Instrument Panel  
2. Mounting Bolts

12. Remove the one (1) nut from the IP. (See Figure 15.)



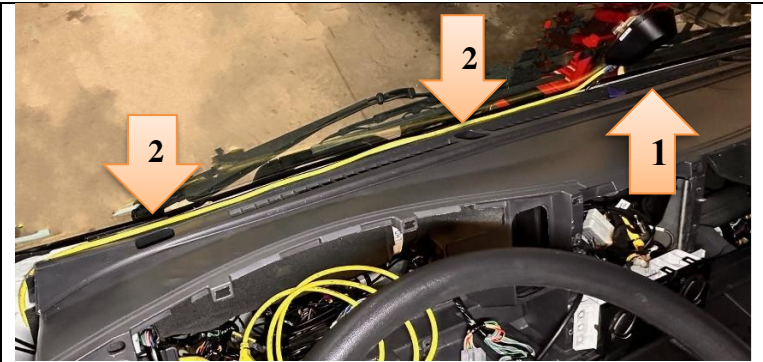
**Figure 15**  
Nut shown removed

13. Pull back on the IP and remove the Mobileye camera cable from behind the instrument panel. (See arrows in Figure 16.)



**Figure 16**  
Camera cable to be removed from behind the instrument panel (shown in Yellow).

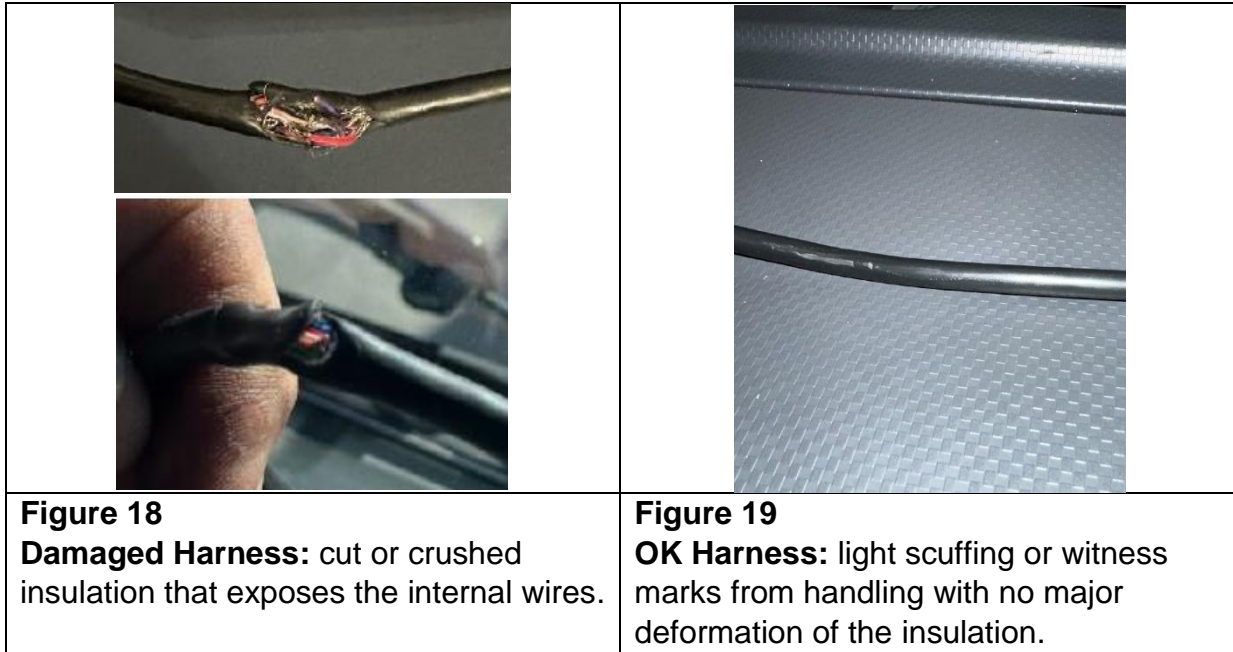
14. Inspect the cable in the three (3) areas; two (2) nearest the IP mounting bolt locations and one (1) where the camera cable passes between the IP and the windshield directly below the camera. (See Figure 17.)



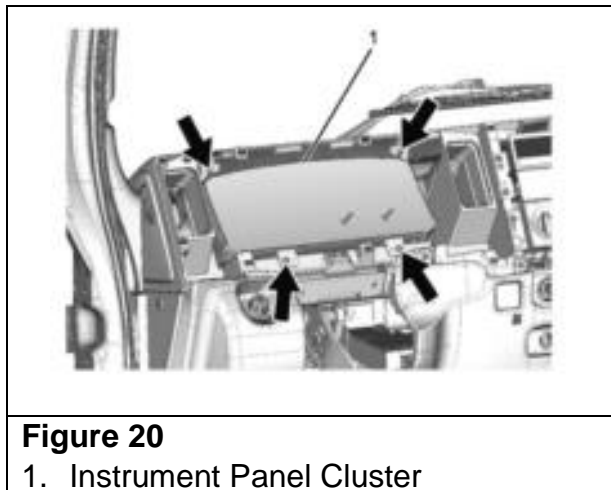
**Figure 17**  
1. Below the Camera Area  
2. Mounting Bolt Area



15. Is the Mobileye camera cable damaged? (See examples of cable damage in Figure 18.)
- If Yes, the Mobileye camera cable is damaged and must be replaced. Take a photo of the damaged section of the cable and refer to the Parts Information section above for further information.
  - If No, (see Figure 19) and continue to the next step to reroute the camera cable.

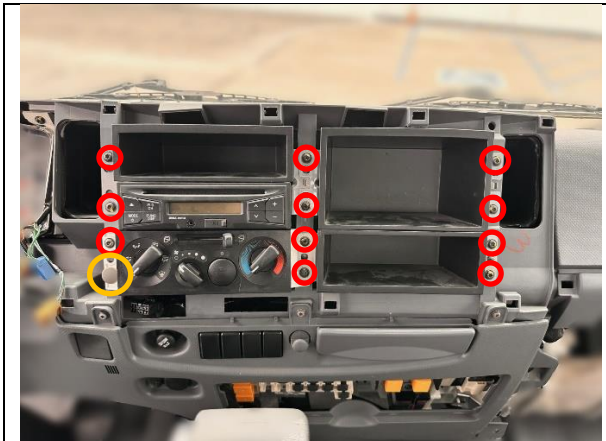


16. Remove the instrument panel cluster from the instrument panel. Remove four (4) T25 screws and disconnect one (1) connector. (See Figure 20.)



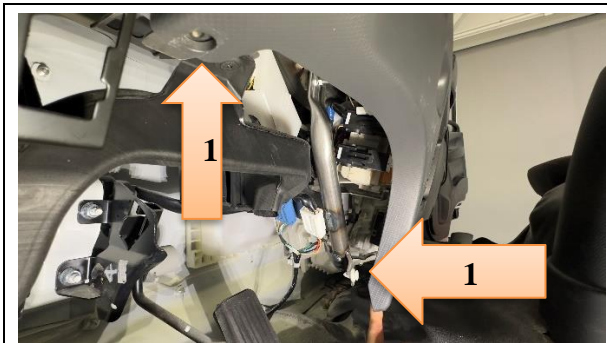
17. Remove the eleven (11) T25 screws securing the cluster compartments, radio and A/C control panel and the one (1) clip for the A/C control panel. (See Figure 21.) Remove the cluster compartments and Radio. Do not remove A/C Control panel. If

the vehicle is equipped with an aftermarket radio, follow the radio manufacturer's instructions for removal.



**Figure 21**

18. Remove the two (2) clips shown in Figure 22 from the instrument panel.



**Figure 22**

1. Clips

19. Cut the two (2) zip ties that are securing the Mobileye System harnesses behind the meter cluster. (See Figure 23.)

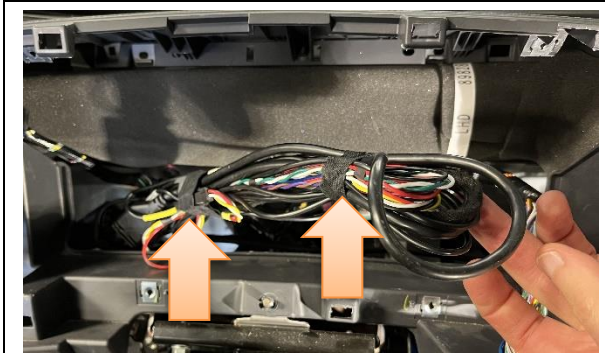


**Figure 23**

Zip Ties

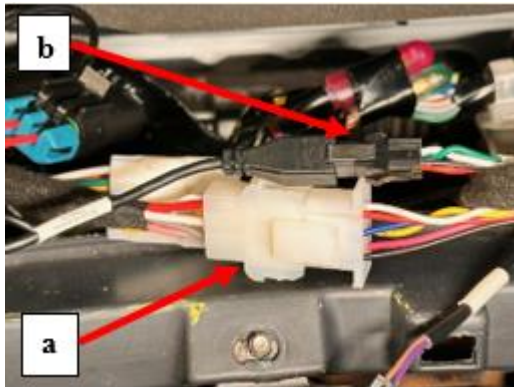
20. Unwrap and discard the tape around the harnesses and separate the camera cable from the other wires. (See Figure 24.)

**NOTE: Pay close attention to how the Mobileye harness is bundled together. You will need to secure these harnesses in the same manner later in this procedure.**

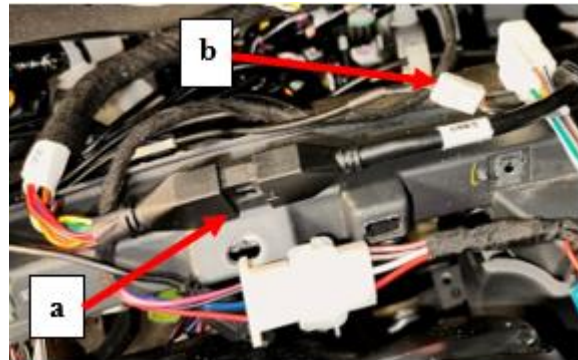


**Figure 24**  
Tape

21. Disconnect the camera cable connections. **For Mobileye 6**, connector MH-2 and the EyeWatch connector MB-3. (See Figure 25.) **For Mobileye 8**, 14 pin (Black) connector and optional GPS connector. (See Figure 26.)



**Figure 25**  
Mobileye 6 Camera Cable (2 connectors).  
a. Connector MH-2  
b. Connector MB-3



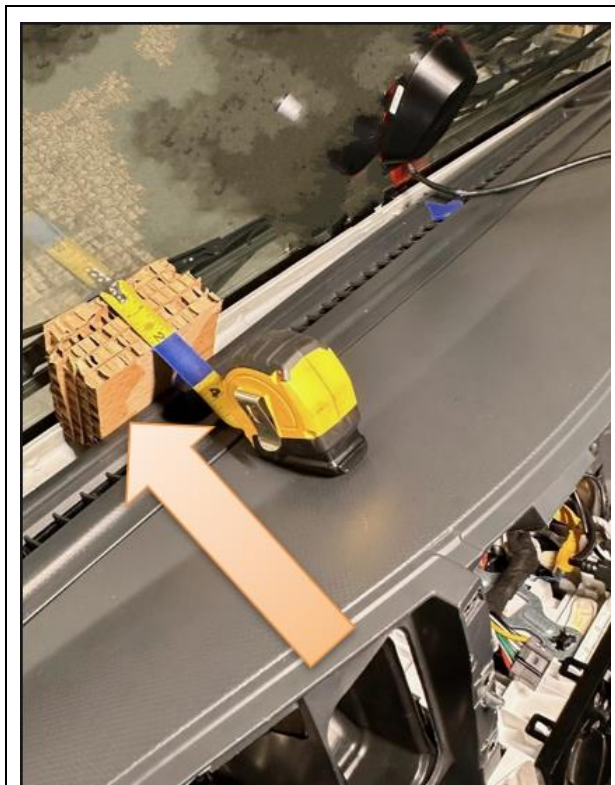
**Figure 26**  
Mobileye 8 Camera Cable (2 connectors).  
a. 14 Pin Black Connector  
b. Optional GPS Antenna Connector

22. Pull out the entire camera cable from its current routing and lay it on top of the IP to the right of the tape mark placed in Step 8. (See Figure 27.)



**Figure 27**  
Current Cable Routing (painted yellow for reference.)  
1. Tape Location

23. Pull the IP away from the windshield to create a 2" gap between the IP and the windshield as shown in Figure 28. Place a piece of wood, cardboard or rubber block (e.g. rubber mallet head) directly inline from the driver's right HVAC vent to maintain this gap.



**Figure 28**  
Item wedged between IP and windshield.

***IMPORTANT: Do not place too much pressure on the windshield! Doing so may result in a broken windshield!***

24. Use a piece of cardboard or something similar to protect the windshield and camera. (See Figure 29.)



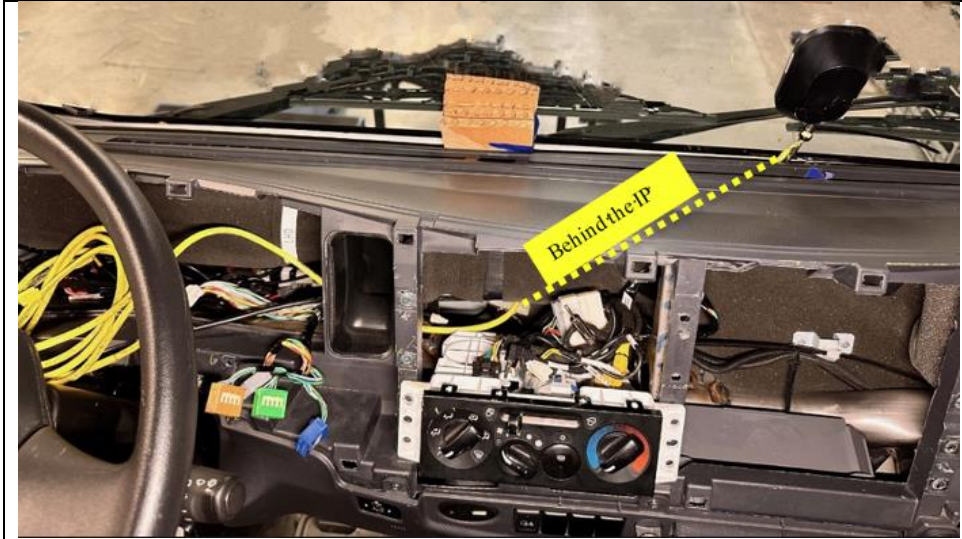
**Figure 29**

25. Using a rotary cutting tool or rat tail file, create a notch (relief) in the IP at the location previously marked in Step 8 where the camera cable will pass between the IP and the windshield. The notch should be at least one-quarter (1/4) inch in depth and in diameter. (See Figure 30.)



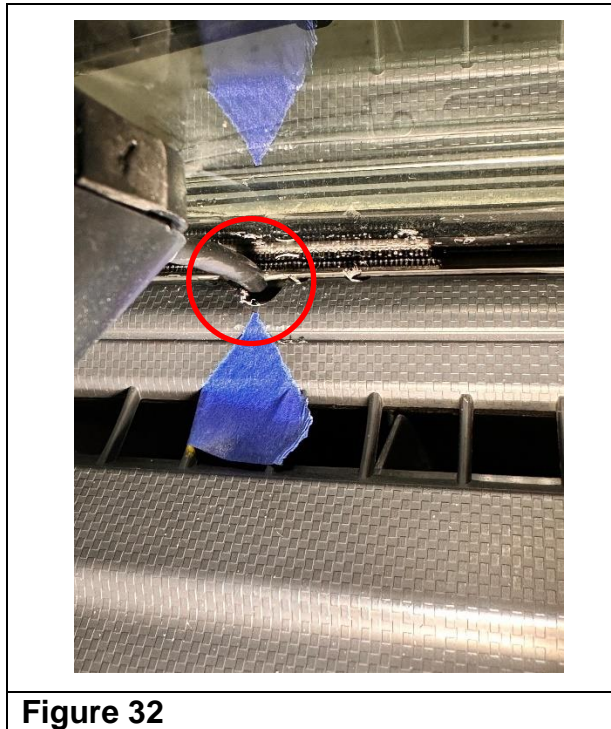
**Figure 30**

26. Route the camera cable down, behind and under the IP and HVAC duct towards the radio opening. Pull out the cup holder for additional access. Grab the end of the camera cable and pull out the remaining length of the cable. Loosely route the cable from the radio opening into the area behind the instrument panel cluster. (See Figure 31.)



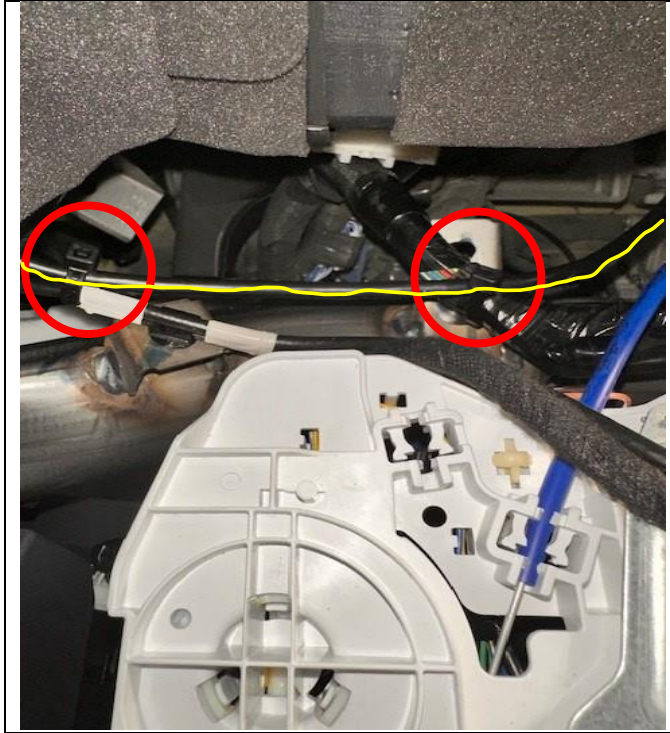
**Figure 31**  
a. New Camera Cable Routing (painted Yellow for reference.)

27. Remove the block or item used to maintain the gap between the IP and the windshield and set the IP back into place. Make sure that the camera cable is routed through the new notch in the IP. (See Figure 32.)



**Figure 32**

28. Install two (2) zip ties to secure the camera cable behind the A/C control panel. If needed, pull out the cup holder for additional access. (See Figure 33.)



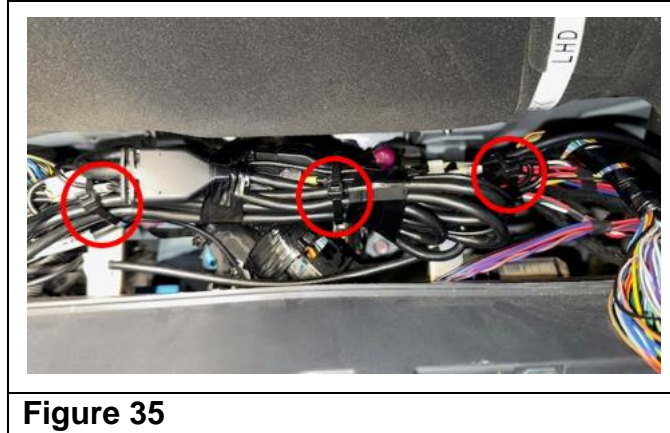
**Figure 33**  
Camera Cable Zip Tie Location

29. Bundle the Mobileye harnesses back together and secure them with electrical tape in the two locations shown in Figure 34.

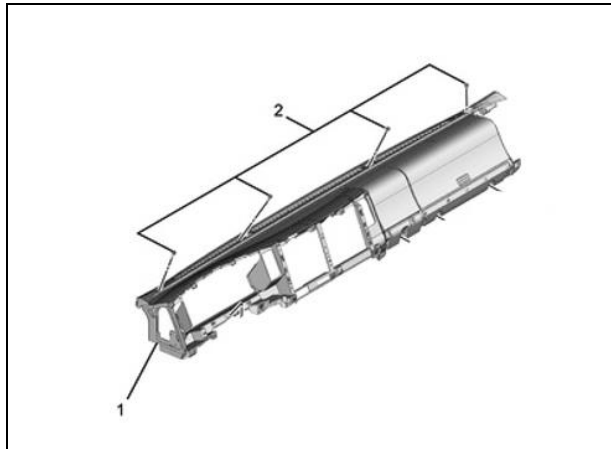


**Figure 34**

30. Secure the bundled Mobileye harnesses to the IP harness using three (3) zip ties. (See Figure 35.)



31. Install the four (4) IP mounting bolts removed in step 11. (See Figure 36.) Ensure the camera cable is routed through the new notch in the IP. **Torque the bolts to: 4.0 N•m (35 lb•in)**

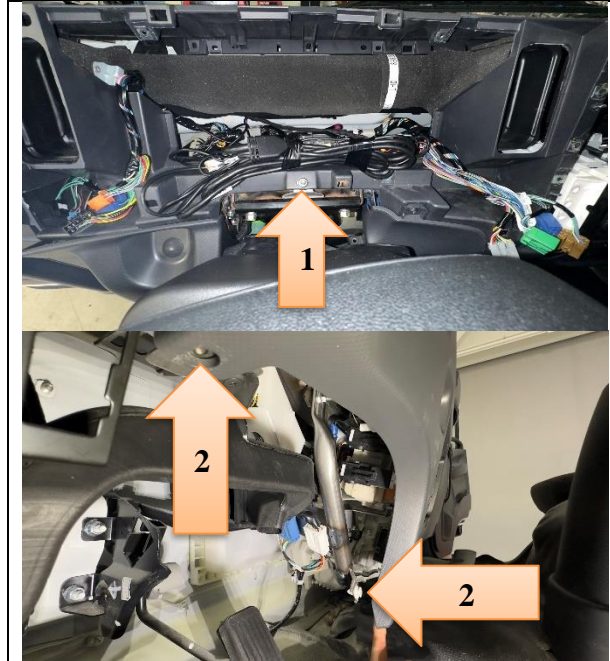


**Figure 36**

- 1. Instrument Panel
- 2. Mounting Bolts

32. Install on the IP the one (1) nut removed in Step 12 and the two (2) clips removed in Step 18. (See Figure 37.) **Torque the nut to: 4.0 N•m (35 lb•in)**

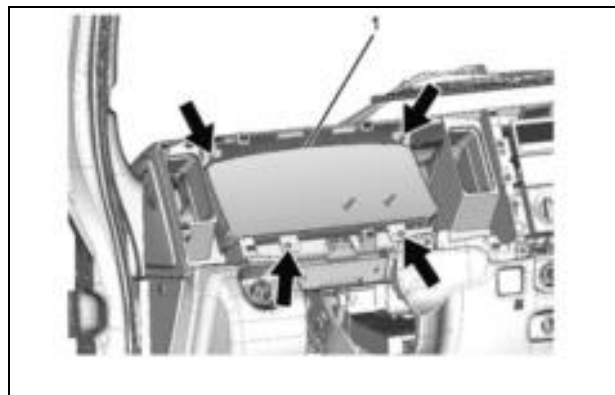




**Figure 37**

1. Nut
2. Clips

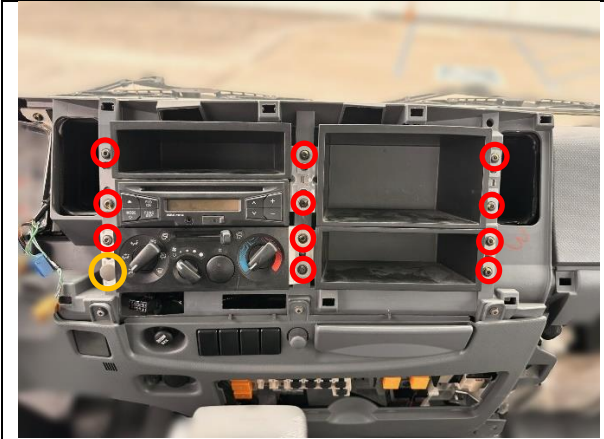
33. Reconnect the instrument panel cluster connector, then install the cluster in the IP and install the four (4) T25 screws removed in Step 16. (See Figure 38.)



**Figure 38**

1. Instrument Panel Cluster

34. Install the cluster compartments, radio and A/C control panel removed in Step 17 (eleven (11) T25 screws and one (1) clip for the A/C control panel). If the vehicle is equipped with an aftermarket radio, follow the manufacturer's instructions for installing the radio. (See Figure 39.) **Torque the screws to: 2.9 N•m (26 lb•in)**



**Figure 39**

35. Install the knee bracket and torque the two (2) 10mm bolts removed in Step 5. (See Figure 40.) **Torque Specification 4.0 N•m (35 lb•in)**



**Figure 40**

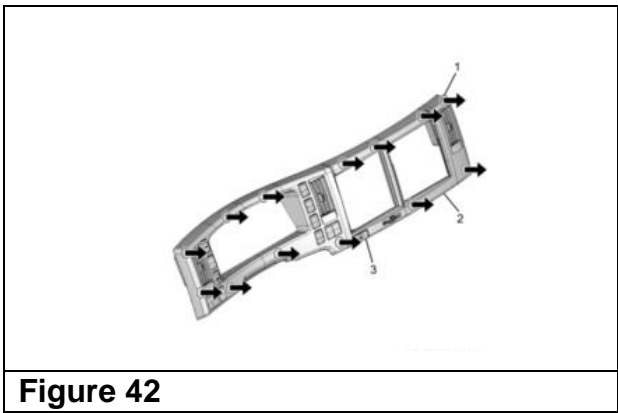
1. Bolts

36. Install the driver side instrument side cover removed in Step 4. (See Figure 41.)



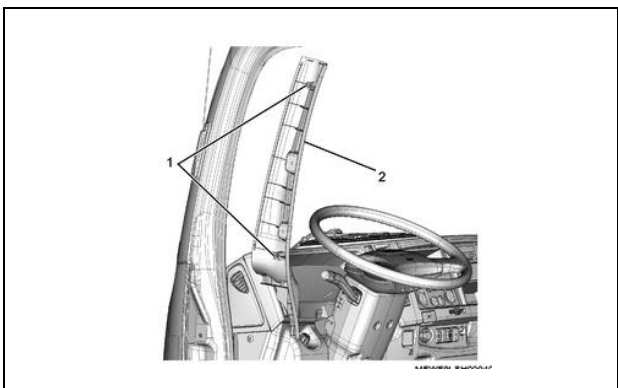
**Figure 41**  
Drivers Side Instrument Side Cover

37. Place the meter cluster bezel onto the IP and be sure to connect all switches. Press the meter cluster bezel back into place. (See Figure 42.)



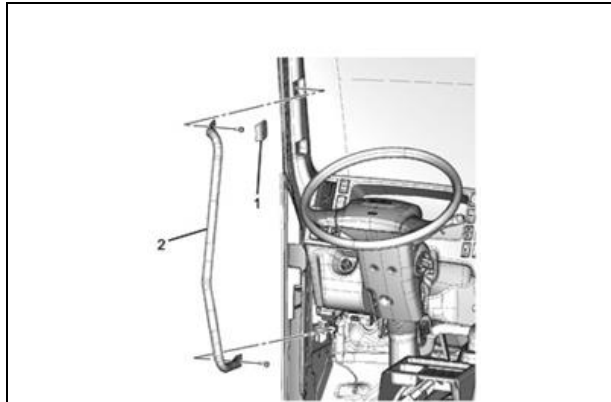
**Figure 42**

38. Install the front pillar trim cover and reinstall the front door weatherstrip. (See Figure 43.)



**Figure 43**  
1. Clips  
2. Front Pillar Trim Cover

39. Install the assist handle to the front pillar (See Figure 44). Torque the mounting bolts. **Torque Specification: 19 N•m (14 lb•ft)**



**Figure 44**  
2. Assist Handle

40. Connect the negative battery cable.
41. Turn the Engine Control Switch to the “ON” position.
42. Press the (+) button on the Mobileye EyeWatch display until it beeps, continue to hold the (+) button and press the (-) button on the display for ~2 seconds until the red gear appears. (See Figure 45.)
43. When the red gear appears, press (+), When the green connectors appear, press (M). Move the turn signal lever to turn left, and then to turn right, verify double arrows appear on the display each time as shown. (See Figure 43.)
- If either turn signal does not operate correctly, check wiring to ensure all connections are fully seated.
  - After confirming both turn signals operate correctly (i.e., the double arrows appeared in the EyeWatch display), turn the Engine Control Switch off.



**Figure 45**  
EyeWatch Display

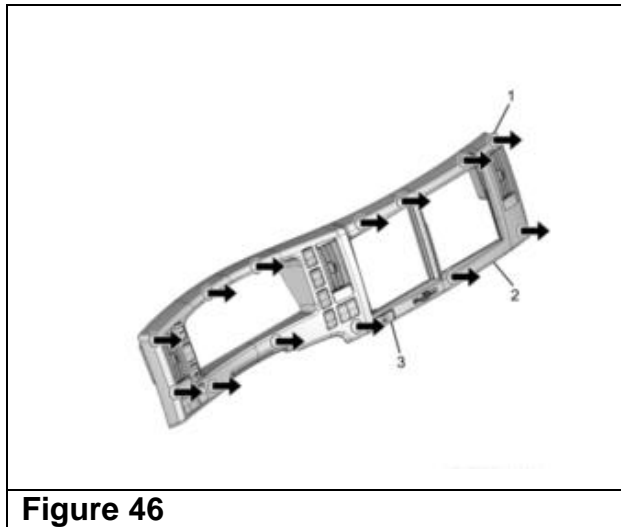
44. Proceed to Applying the Campaign Label (Step 108).

## NEW HARNESS INSTALLATION PROCEDURE

45. Turn the Engine Control Switch to the “Lock” position, wait at least three minutes and then disconnect the negative battery cable.

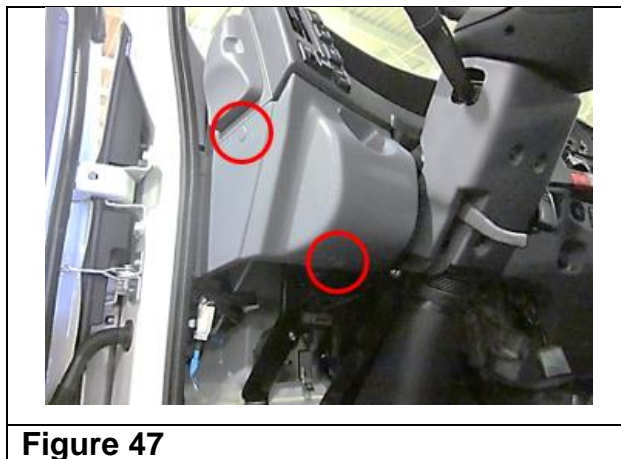
***IMPORTANT: The ECM may malfunction if the battery is disconnected within 3 minutes of turning the Engine Control Switch off.***

46. Remove the meter cluster bezel from the instrument panel by pulling forward and disconnecting the switches. (See Figure 46.)



**Figure 46**

47. Remove the driver side instrument side cover. (See Figure 47.)



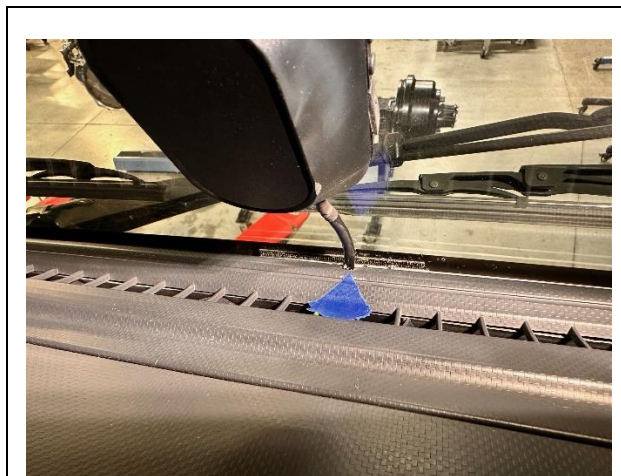
**Figure 47**

48. Remove the two (2) 10mm bolts and remove the knee bracket. (See Figure 48.)



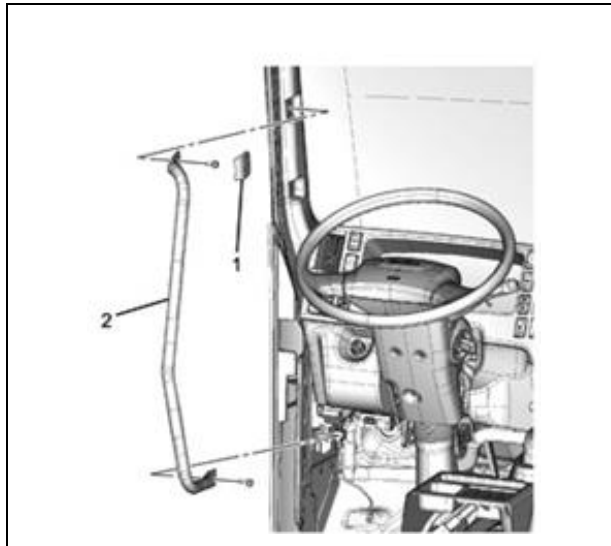
**Figure 48**  
1. Bolts

49. Using one (1) inch of masking tape, mark the location near the center of the instrument panel where the Mobileye camera cable goes under the instrument panel. (See Figure 49.)



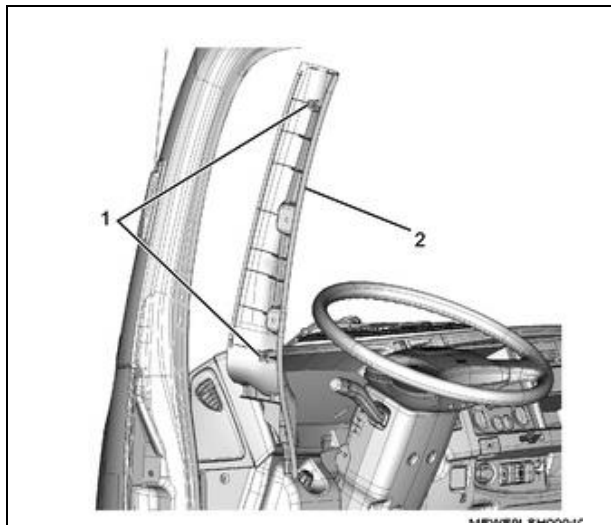
**Figure 49**  
Taped Location

50. Open the assist handle upper cover using a flathead screwdriver and remove the upper bolt. Then remove the lower bolt of the assist handle and remove the assist handle from the front pillar. (See Figure 50.)



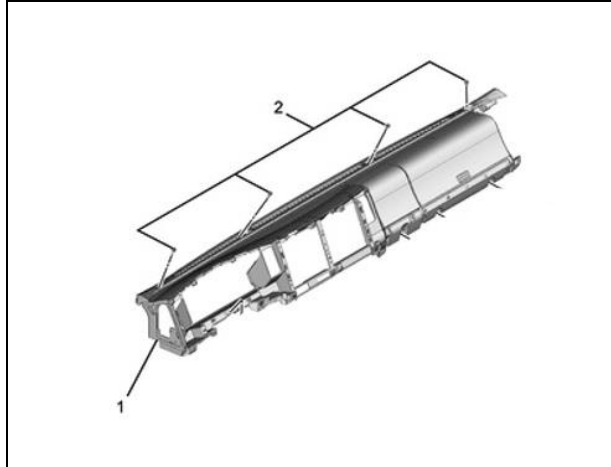
**Figure 50**  
Assist Handle

51. Pull the front door weatherstrip away from the front pillar trim cover. Then pull the front pillar trim cover up and remove it from the front pillar. (See Figure 51.)



**Figure 51**  
2. Front Pillar Trim Cover

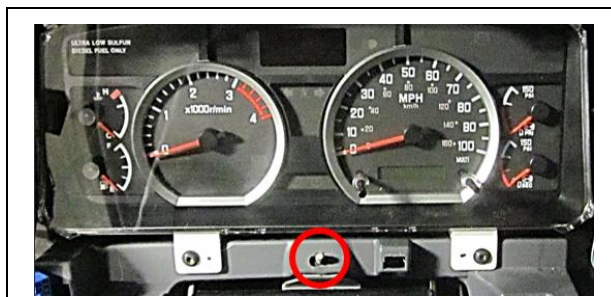
52. Remove the four (4) instrument panel (IP) mounting bolts. (See Figure 52.)



**Figure 52**

1. Instrument Panel
2. Mounting Bolts

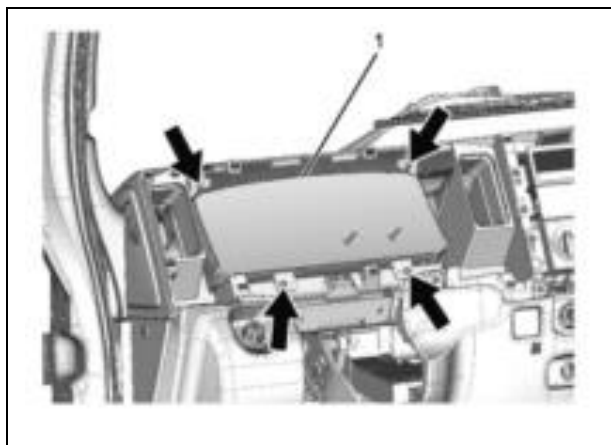
53. Remove the one (1) nut from the IP. (See Figure 53.)



**Figure 53**

Nut shown removed

54. Remove the instrument panel cluster from the instrument panel. Remove four (4) T-25 screws and disconnect one (1) connector. (See Figure 54.)

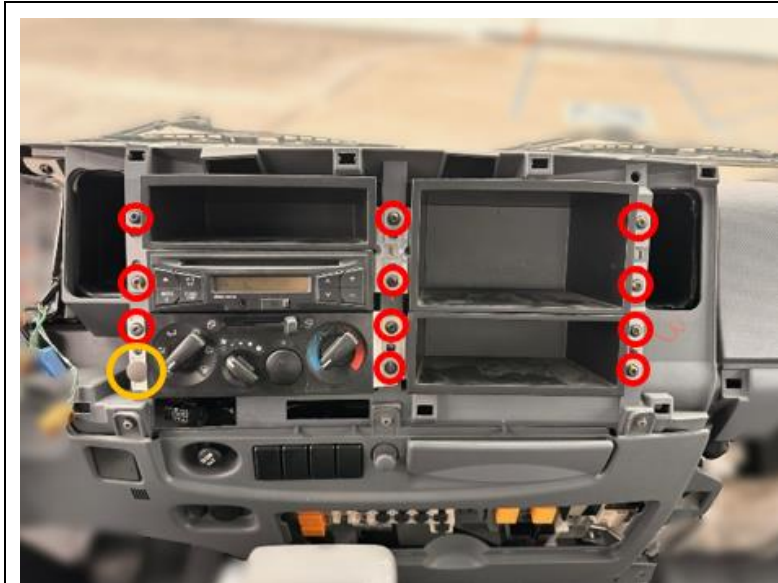


**Figure 54**

1. Instrument Panel Cluster

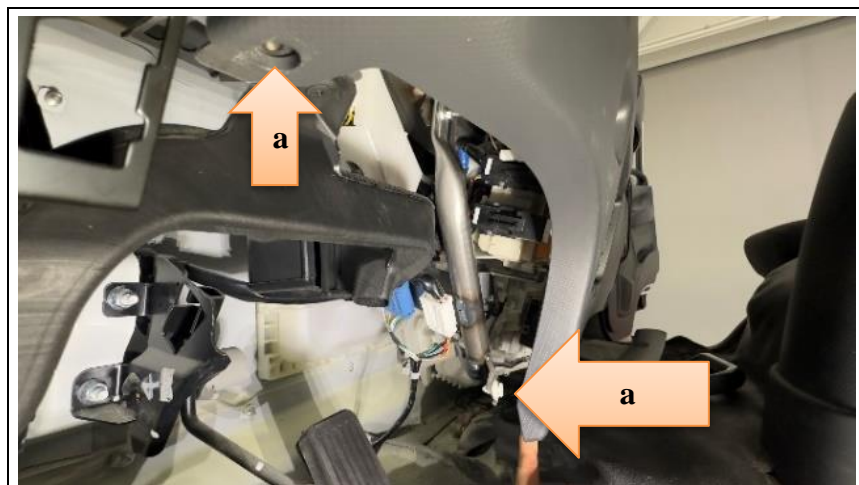


55. Remove the eleven (11) T25 screws securing the cluster compartments, radio and A/C control panel and the one (1) clip for the A/C control panel. (See Figure 55.) Remove the cluster compartments and radio. Do not remove the A/C Control panel. If the vehicle is equipped with an aftermarket radio, follow the manufacturer's instructions for removal.



**Figure 55**

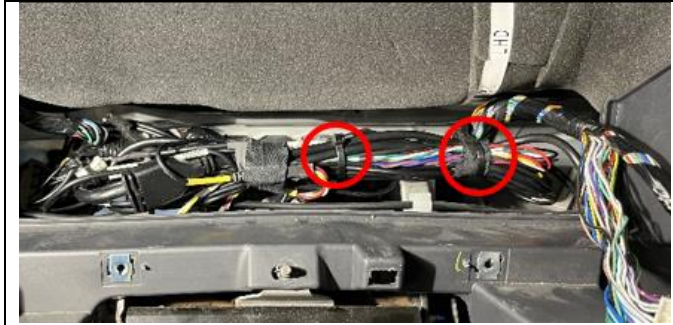
56. Remove the two (2) clips shown in Figure 56 from the instrument panel.



**Figure 56**

a. Clips

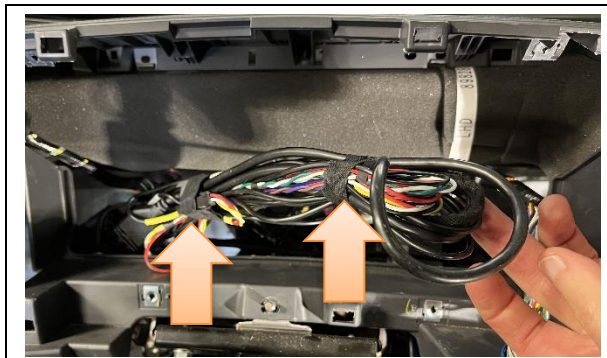
57. Cut the two (2) zip ties that are securing the Mobileye System harnesses behind the meter cluster. (See Figure 57.)



**Figure 57**  
Zip Ties

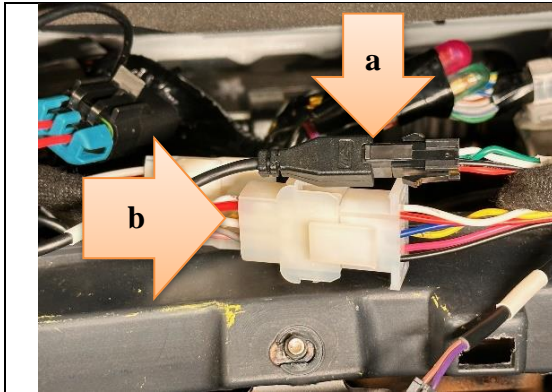
58. Unwrap and discard the tape, around the harnesses and, separate the Mobileye harnesses from the other wires. (See Figure 58.)

**NOTE: Pay close attention to how the Mobileye harness is bundled together. You will need to secure these harnesses in the same manner later in this procedure.**



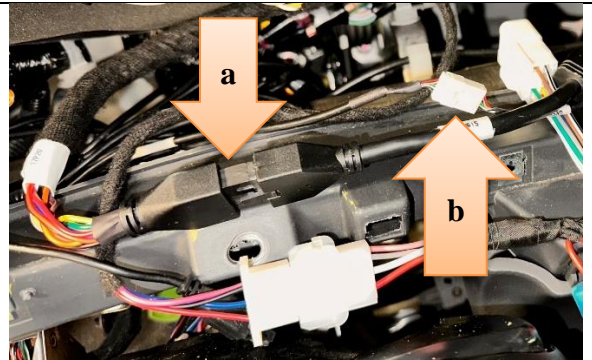
**Figure 58**  
Tape

59. Disconnect the camera cable. **For Mobileye 6**, connector MH-2 and the EyeWatch connector MB-3. (See Figure 59.) **For Mobileye 8**, 14 pin (Black) connector and optional GPS connector. (See Figure 60.)



**Figure 59**  
**Mobileye 6**

- a. EyeWatch Connector MB-3  
b. T-Harness Connector MH-2



**Figure 60**  
**Mobileye 8**

- a. Camera Cable  
b. GPS Connector (optional)

60. Pull out the entire camera cable from its current routing and lay it on top of the IP to the right of the tape mark placed in Step 49. (See Figure 61.)



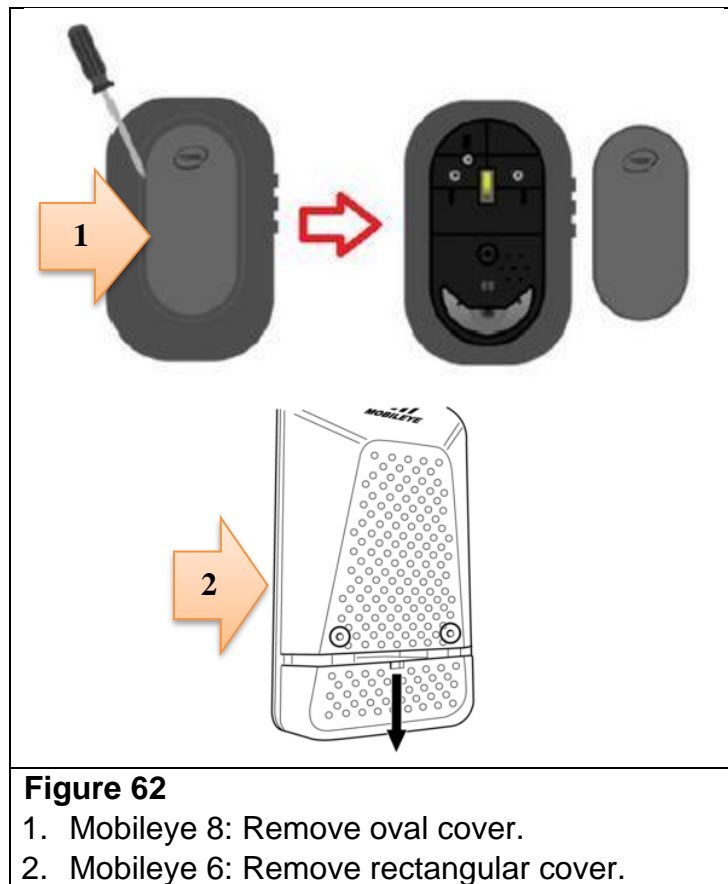
**Figure 61**

- Current Cable Routing (painted yellow for example.)  
1. Tape Location

***IMPORTANT: Place a towel or cloth below the camera before removing the camera. The screws are very small and can be easily lost, if dropped.***

61. Place a clean towel or tray on the IP, below the camera, to catch any screws that may be dropped during this process.

62. **For Mobileye 8**, use a small flat screwdriver, to pop out the oval cover of the camera. If equipped with Mobileye 6, use a small flat tip screwdriver to remove the rectangular cover of the camera (See Figure 62.)

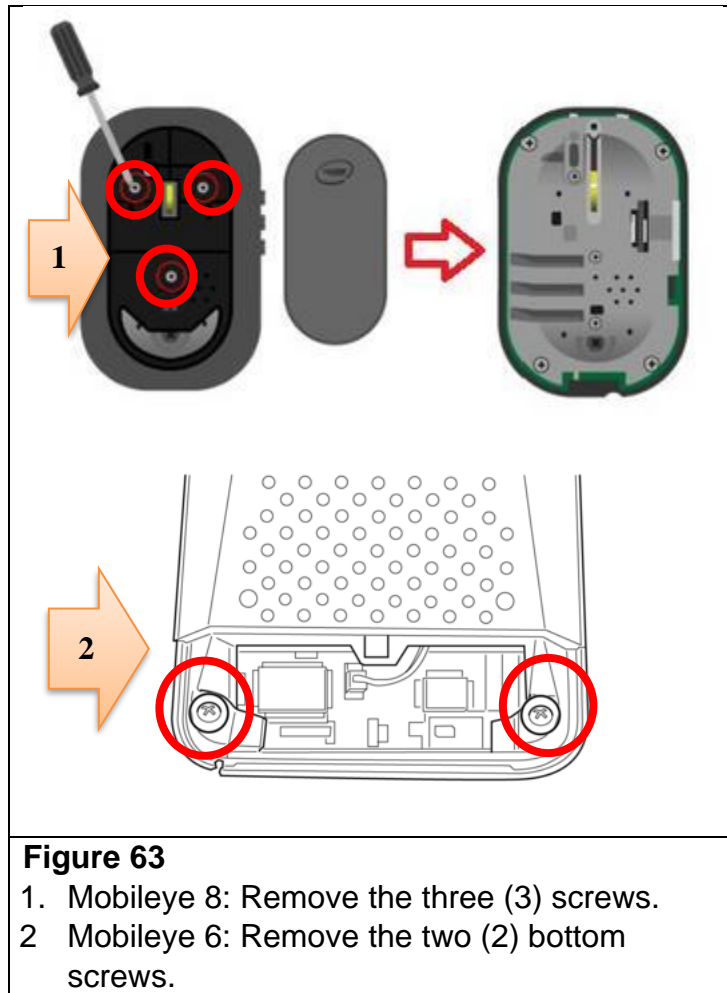


**Figure 62**

1. Mobileye 8: Remove oval cover.
2. Mobileye 6: Remove rectangular cover.

**IMPORTANT:** Be sure to use a *Philips screwdriver that has the correct size tip and is small enough to align straight into the screw. Incorrect size or poor alignment can damage the screw.*

63. Using a small Philips screwdriver: **for Mobileye 8**, remove the three (3) camera cover screws; and **for Mobileye 6**, remove the two (2) lower screws. (See Figure 63.)

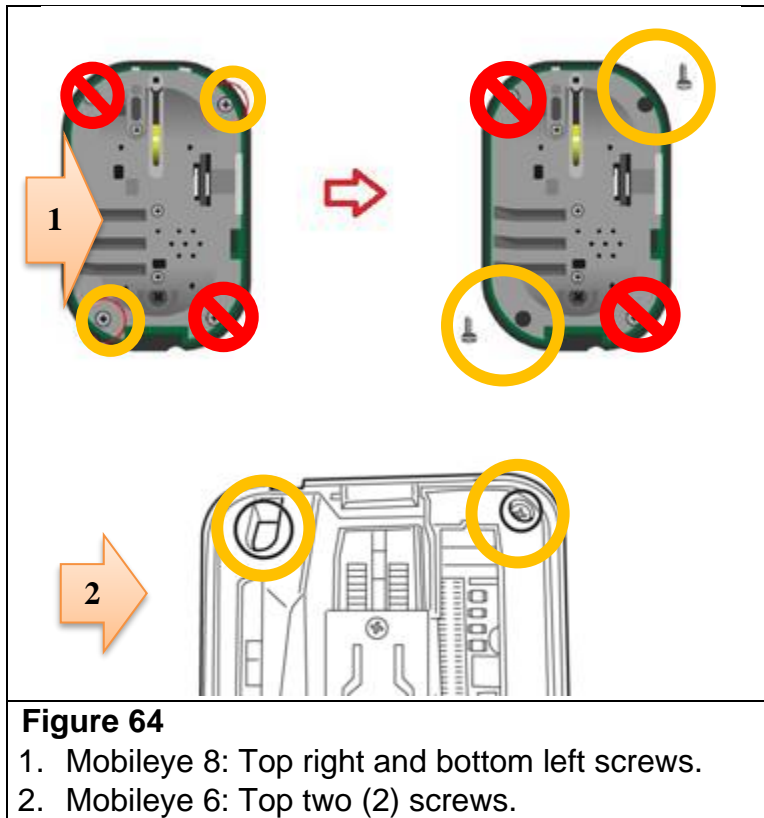


**Figure 63**

1. Mobileye 8: Remove the three (3) screws.
2. Mobileye 6: Remove the two (2) bottom screws.

64. Using a small Philips screwdriver, remove the two (2) camera mounting screws shown in Figure 64.

***IMPORTANT: Do not unscrew the upper left and lower right screws of the Mobileye 8 camera. This will void the warranty!***

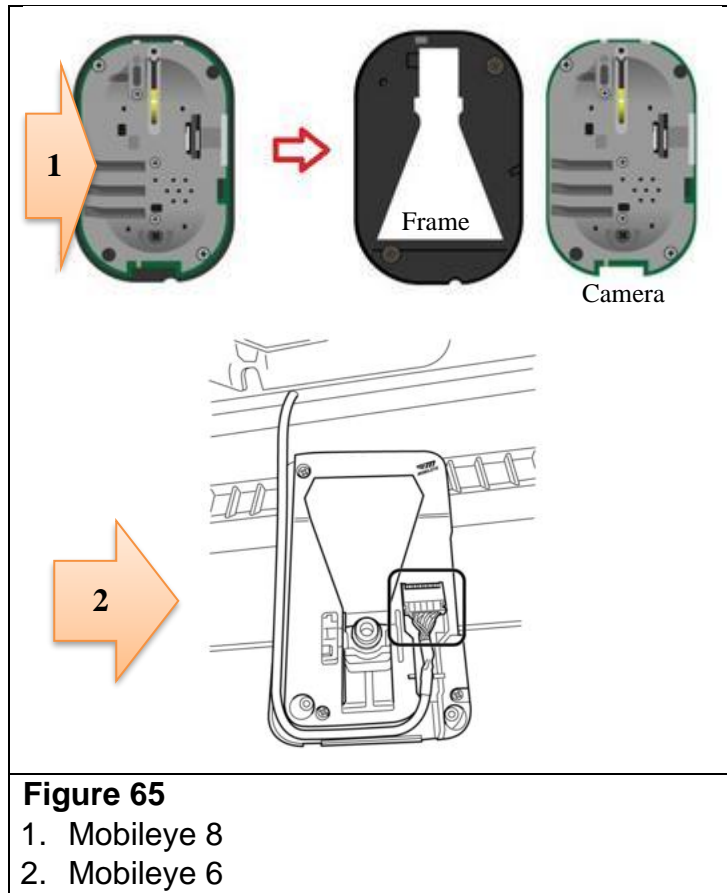


**NOTE: Pay attention to the camera/cable connection and note the position in which the cable is connected.**

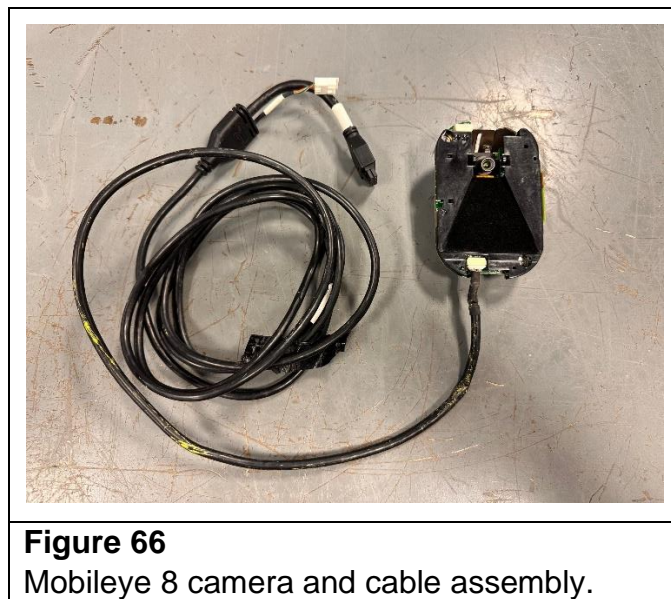
65. Gently remove the camera chassis from the camera frame (the frame is taped to the windshield). (See Figure 65.)

***IMPORTANT: Do not attempt to remove the camera frame from the windshield. Removing the frame from the windshield is NOT an approved repair for the Isuzu dealer.***

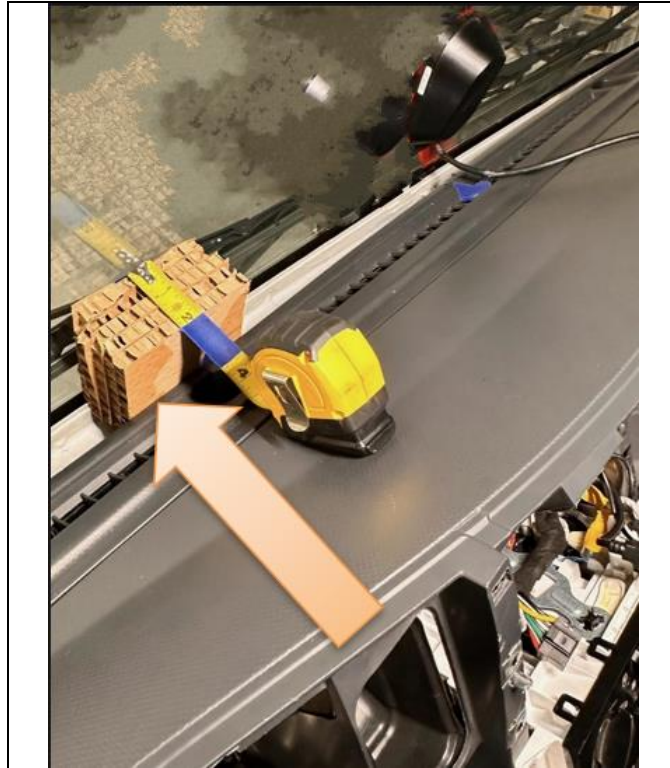
**NOTE: Be sure the rubber buttons located in the camera frames of both Mobileye 6 and 8 do not fall out.**



66. Place the camera and cable assembly on a clean workbench or table. Ensure that the camera chassis and lens cannot (and do not) get dirty. (See Figure 66 – for an example.)

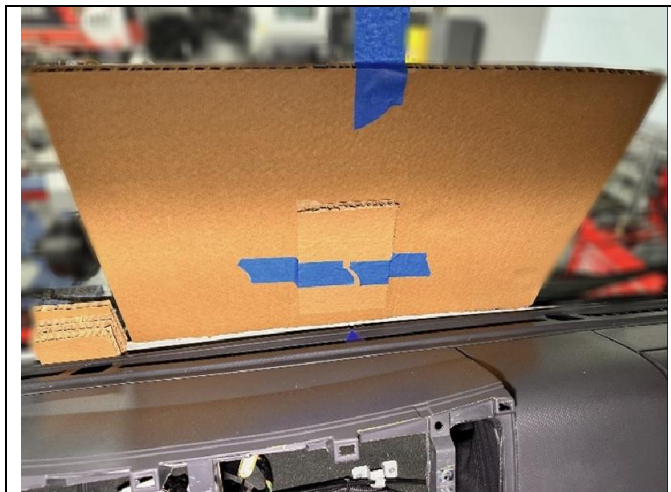


67. Pull the IP away from the windshield to create a 2" gap between the IP and the windshield as shown in Figure 67. Place a piece of wood, cardboard or rubber block (e.g. rubber mallet head) directly inline from the driver's right HVAC vent to maintain this gap.



**Figure 67**

68. Use a piece of cardboard or something similar to protect the windshield. (See Figure 68.)

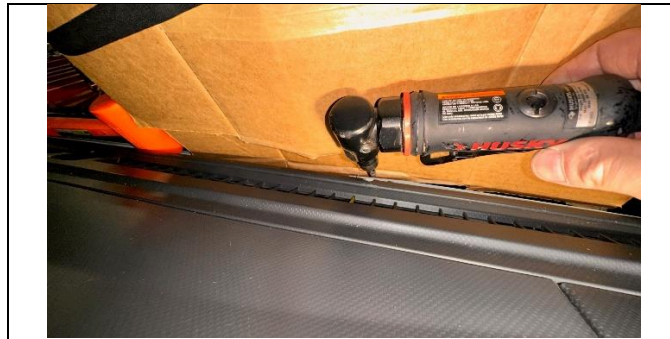


**Figure 68**

69. Using a rotary cutting tool or rat tail file, create a notch (relief) in the IP at the location previously marked by tape in Step 49 where the camera harness will pass between



the IP and the windshield. The notch should be at least one-quarter (1/4) inch in depth and in diameter. (See Figure 69.)

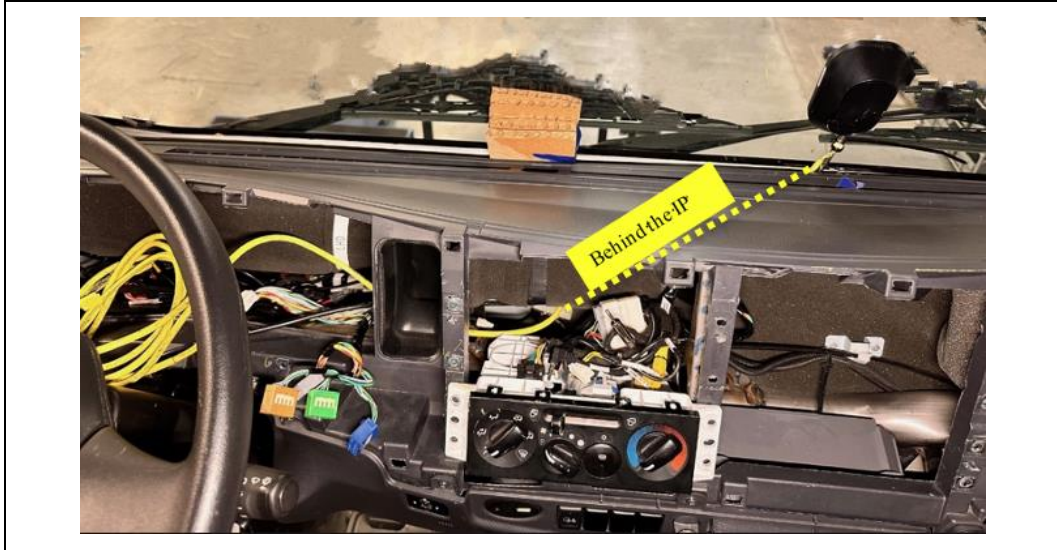


**Figure 69**

70. Carefully disconnect the old camera cable from the camera and install the new camera cable into the camera at the same connection location.
71. Install the camera with new cable attached onto the camera frame.

**NOTE: Be sure the rubber buttons located in the camera frame are positioned properly when installing the camera chassis.**

72. Install and tighten the two (2) camera mounting screws removed in Step 64 to attach the camera chassis to the camera frame. (See Figure 64.)
73. **For Mobileye 8**, install and tighten the three (3) screws for the main back cover removed in Step 63. If equipped with Mobileye 6 install and tighten the two (2) lower screws. (See Figure 63.)
74. **For Mobileye 8**, re-install the oval cover onto the back of the Mobileye camera. If equipped with **Mobileye 6**, re-install the rectangular cover. (See Figure 62.)
75. Route the new camera cable down, behind and under the instrument panel and HVAC duct toward the radio opening. If necessary, pull out the cup holder for more access. Grab the end of the camera cable and pull out the remaining length of cable. Loosely route the cable from the radio opening into the area behind the instrument panel cluster. (See Figure 70.)



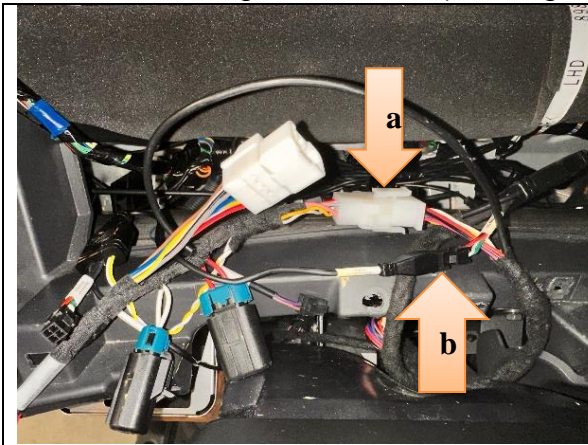
**Figure 70**

New camera cable routing (painted in Yellow for reference).

76. Connect the new harnesses to the camera cable as follows:

**NOTE: Some of the connectors on the harnesses are not used. Pay close attention to how the original harnesses are connected.**

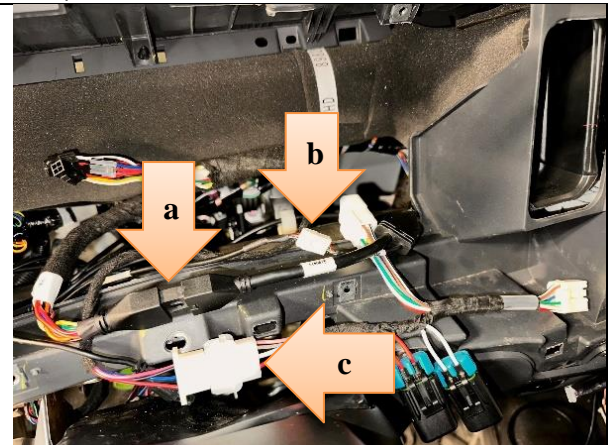
- a. **Mobileye 6:** Connect the camera cable to the T-Harness connector MH-2 and EyeWatch input connector MB-3. (See Figure 71.)
- b. **Mobileye 8:** Connect the camera cable to the signal harness 14 pin black connector and, if equipped, to the optional GPS antenna. Connect the T-Harness connector MH-2 to the signal harness. (See Figure 72.)



**Figure 71**

Mobileye 6

- a. Connector MH-2
- b. Connector MB-3



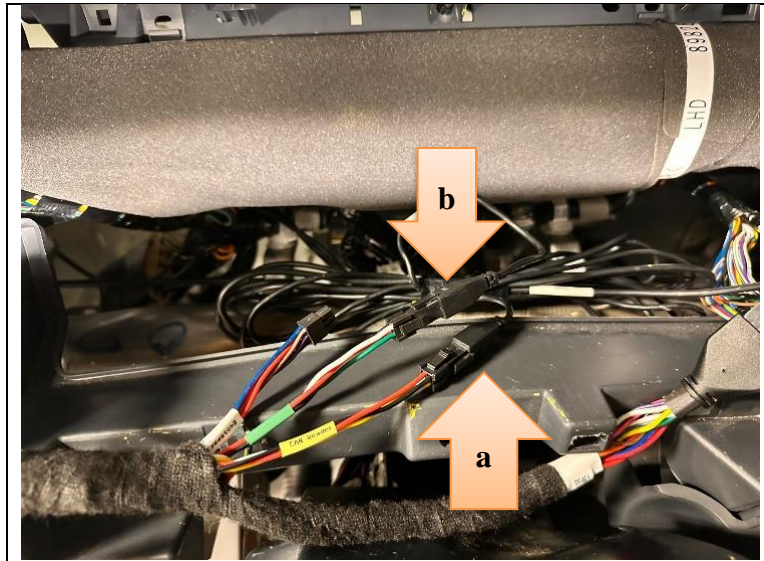
**Figure 72**

Mobileye 8

- a. 14 Pin (Black) Connector
- b. GPS Antenna Connector (optional)
- c. Connector MH-2

77. **Mobileye 8 ONLY:** Disconnect the CAN reader connector from the old harness and plug it in to the new harness. Disconnect the old EyeWatch harness and plug it in to the new harness. (See Figure 73.)

**NOTE: The EyeWatch and CAN reader connections are the same shape. Be careful not to mix them up. If needed, trace each harness connector back to its origin.**



**Figure 73**

- a. CAN Reader Connector
- b. EyeWatch Display Connector

78. Following the original routing of the T-Harness, feed the T-Harness alongside the IP harness down to the left side of the steering column. (See Figure 74.) Then:

- a. **For Mobileye 6:** Proceed to Step 79.
- b. **For Mobileye 8:** Skip to Step 87.



**Figure 74**  
T-Harness

***IMPORTANT: Steps 79 through 87 apply only to Mobileye 6.***

79. Remove the Data Link Connector (DLC) from the bracket. If equipped with a green 9-pin Deutsch connector remove the 10mm bolt and locking plate to separate the DLC from the bracket.
80. Locate the CAN reader and remove the tape securing it to the DLC harness. (See Figures 75 and 76.)



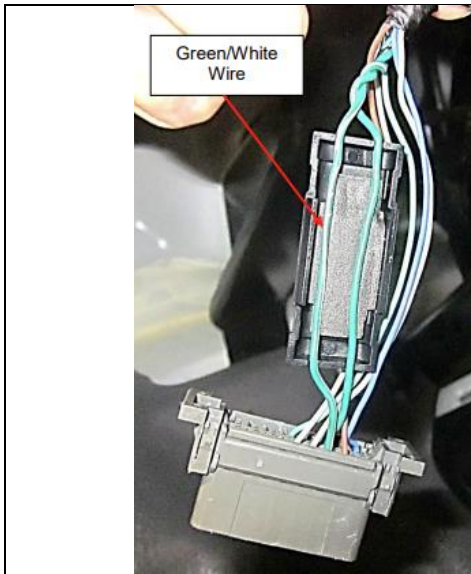
**Figure 75**  
2019-2021 MY



**Figure 76**  
2022-2023 MY

81. Using a small flat head screwdriver, pry open the caps for the old and new CAN readers.

82. Remove the adhesive tape backing from the new CAN reader cover.
83. Transfer the CAN low (Solid color) wires and CAN high (Striped color) wires from the old CAN reader cap into the new CAN reader cap. (See Figures 77 and 78.)



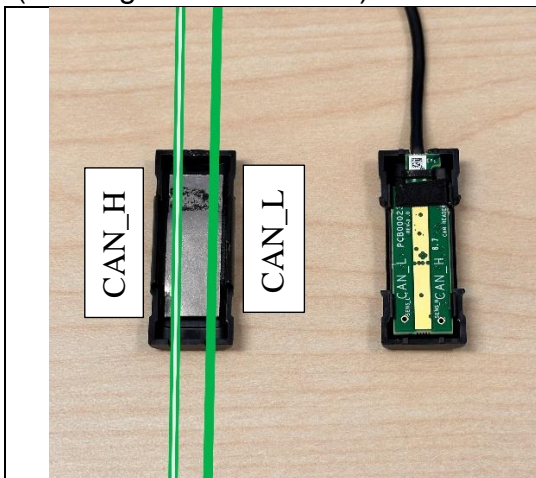
**Figure 77**  
2019-2021 MY



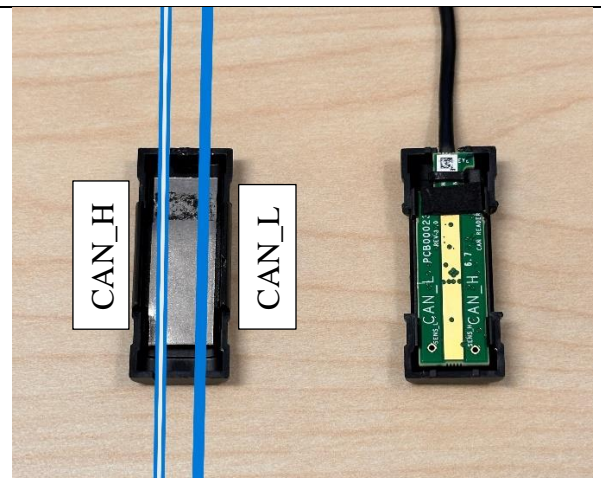
**Figure 78**  
2022-2023 MY

***IMPORTANT: Do not switch the orientation of the CAN wires. Failure to follow these instructions carefully will result in Mobileye not working properly.***

84. Align the new CAN reader so that CAN\_H aligns with the CAN high (Striped color) wire and CAN\_L aligns with the CAN low (Solid color) wire and snap it into the cap. (See Figures 79 and 80.)



**Figure 79**  
2019-2021 MY  
a. CAN High (Green wire with stripe)  
b. CAN Low (Solid green wire)



**Figure 80**  
2022-2023 MY  
a. CAN High (Blue wire with stripe)  
b. CAN Low (Solid blue wire)

85. Tape the new CAN reader back to the DLC harness using electrical tape. (See Figures 81 and 82.)



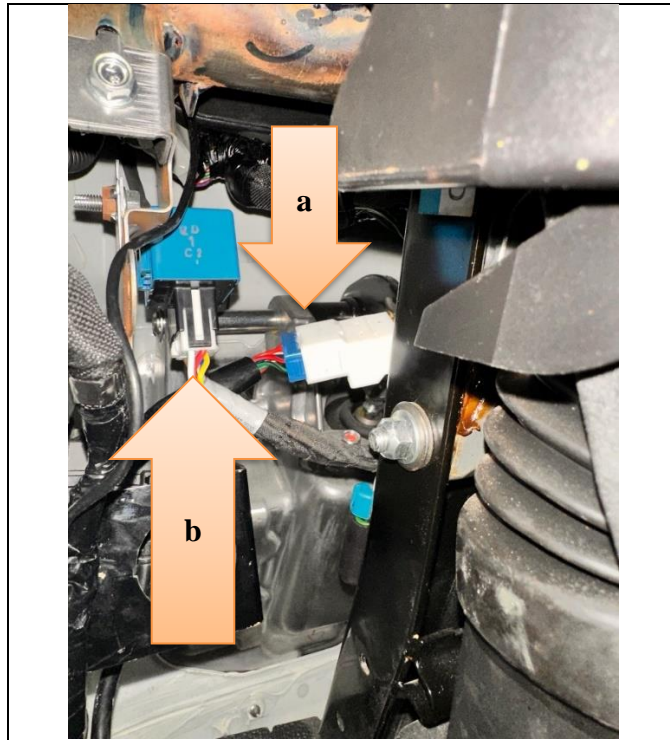
**Figure 81**  
2019-2021 MY



**Figure 82**  
2022-2023 MY

86. Disconnect the EyeWatch display connector from the old T-Harness and reconnect it to the new T-Harness connector labeled "EyeWatch output".

87. Disconnect the old T-Harness from both B-216 and the flasher module and remove the old T-Harness from the vehicle. (See Figure 83.)



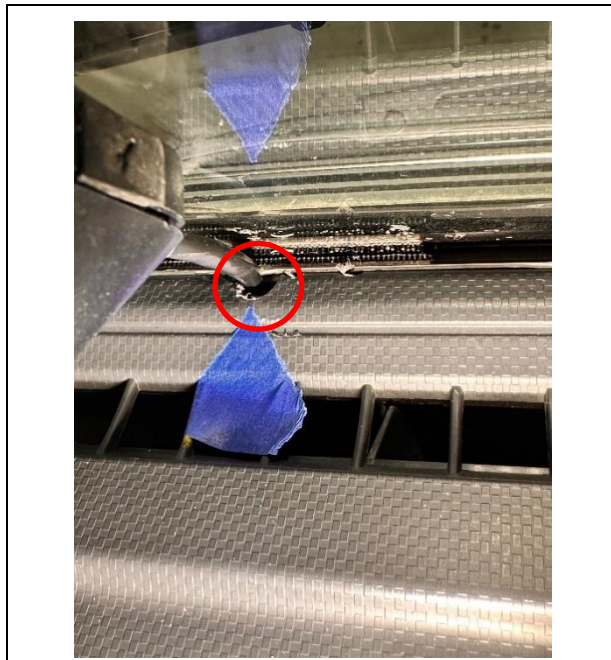
**Figure 83**

- a. Connector B-216  
b. Flasher Module Connector

88. **For Mobileye 8** only, disconnect the old T-Harness from both the B-216 connector and the flasher module and remove the old T-Harness and signal harness from the vehicle.
89. Install the new T-Harness into the connector B-216 and the flasher module. Refer to Figure 83.

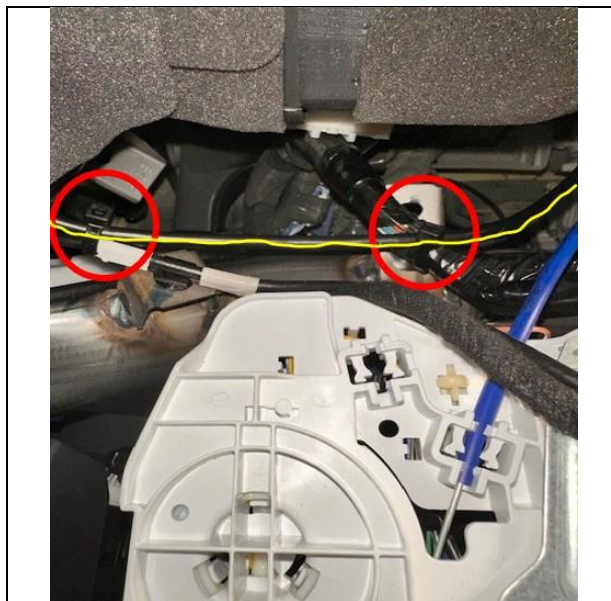
***IMPORTANT: Steps 90 through 108 apply to both Mobileye 6 and Mobileye 8.***

90. Remove the block or item that was used to maintain the gap between the IP and the windshield and set the IP back in place. Make sure that the camera cable is routed through the new notch in the IP. (See Figure 84.)



**Figure 84**  
Cable Notch

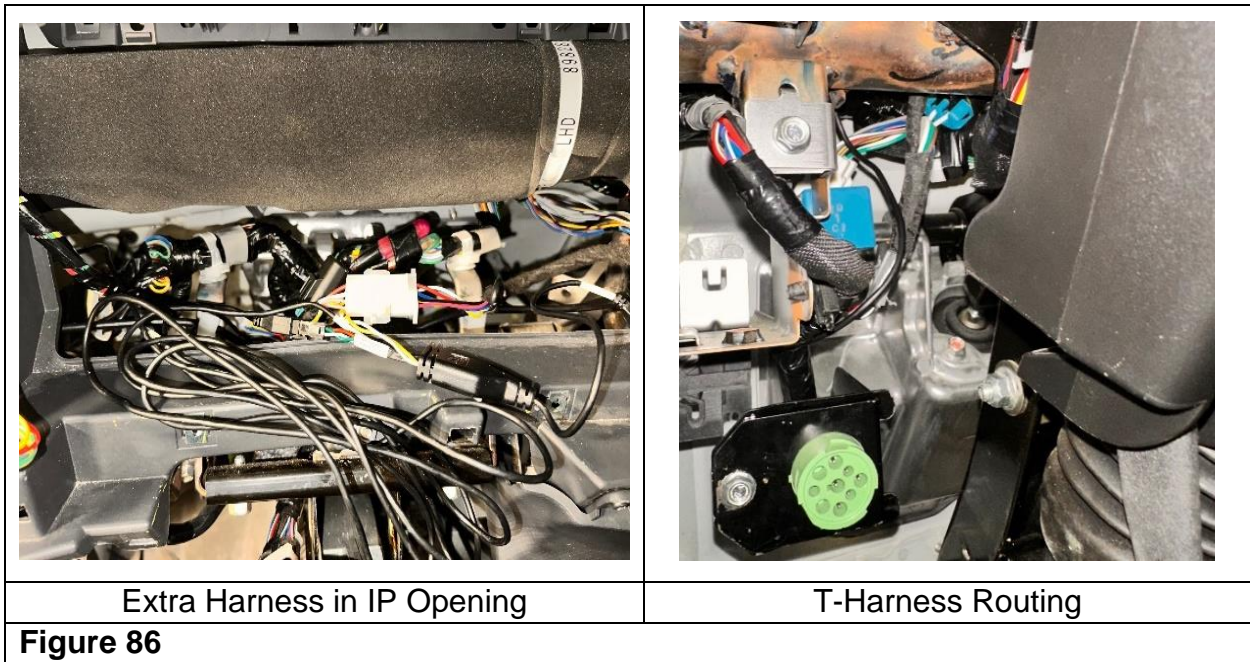
91. Install two (2) zip ties to secure the harness behind the radio. If needed, pull out the cup holder for more access. (See Figure 85.)



**Figure 85**

92. Pull any extra harness length up into the IP opening. Ensure that the T-Harness, and, **for Mobileye 6**, the CAN reader harness, are routed up and away into their original positions. (See Figure 86.)

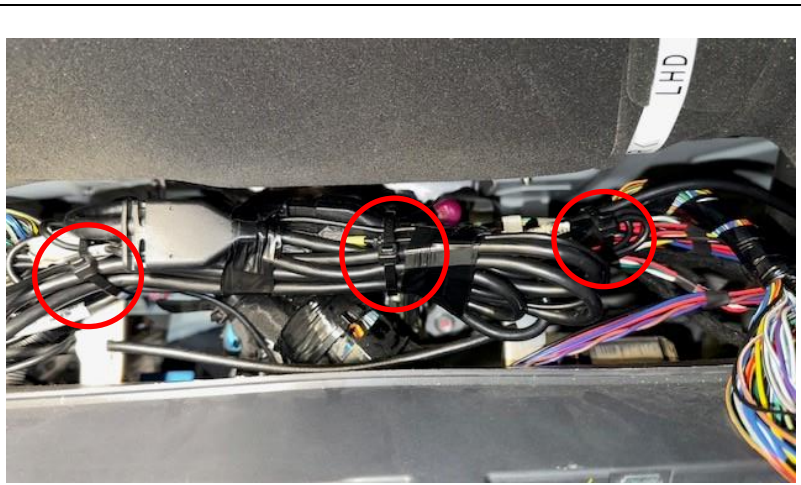




93. Bundle the Mobileye harnesses back together and secure them with electrical tape in the two locations shown in Figure 87.



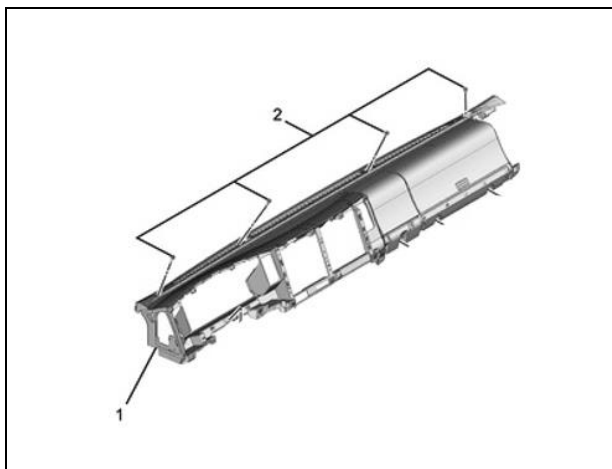
94. Secure the bundled Mobileye harnesses to the IP harness using three (3) zip ties. (See Figure 88.)



**Figure 88**

**IMPORTANT:** Ensure that the camera cable is routed through the notch created in Step 69.

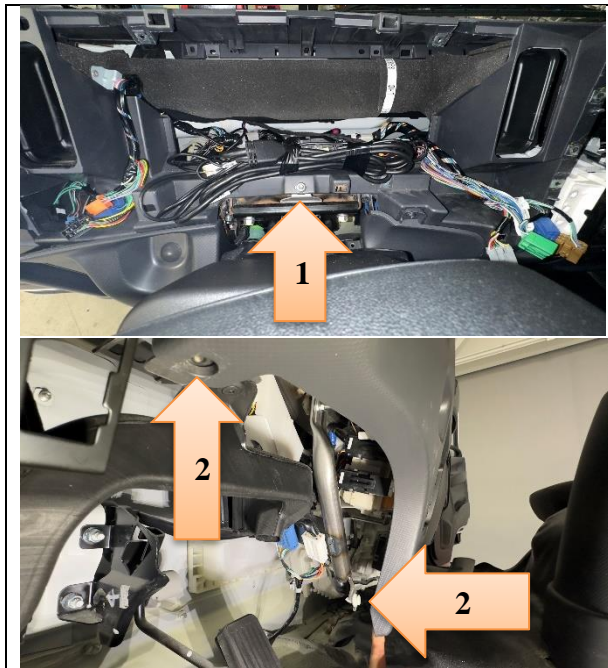
95. Install and torque the four (4) IP mounting bolts removed in Step 52. (See Figure 89.)  
**Torque specification: 4.0 N•m (35 lb•in)**



**Figure 89**

1. Instrument Panel  
2. Mounting Bolts

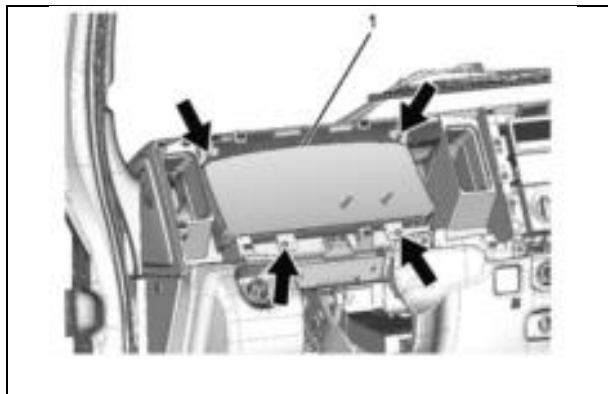
96. Install on the IP the one (1) nut on removed in Step 53 and the two (2) clips. (See Figure 90.) **Torque the nut to: 4.0 N•m (35 lb•in)**



**Figure 90**

1. Nut
2. Clips

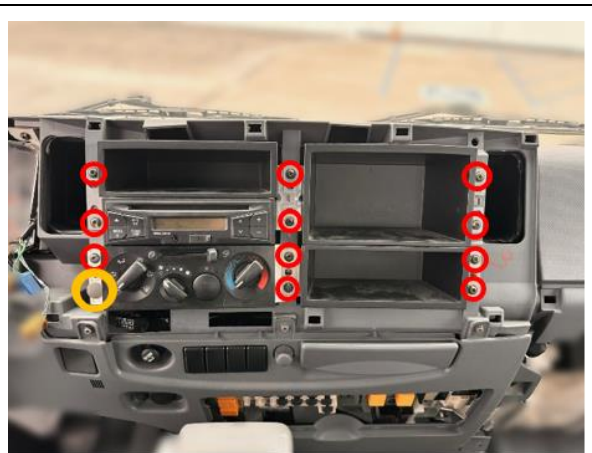
97. Reconnect the instrument panel cluster connector, then install the cluster in the IP and install the four (4) T25 screws removed in Step 54. (See Figure 91.)



**Figure 91**

1. Instrument Panel Cluster

98. Install the cluster compartments, radio and A/C control panel removed in Step 55 (eleven (11) T25 screws and one (1) clip for the A/C control panel). If the vehicle is equipped with an aftermarket radio, follow the manufacturer's instructions in installing the radio. (See Figure 92.) **Torque the screws to 2.9 N•m (26 lb•in)**



**Figure 92**

99. Install the knee bracket and torque the two (2) 10mm bolts removed in Step 48. (See Figure 93.) **Torque Specification 4.0 N•m (35 lb•in)**



**Figure 93**

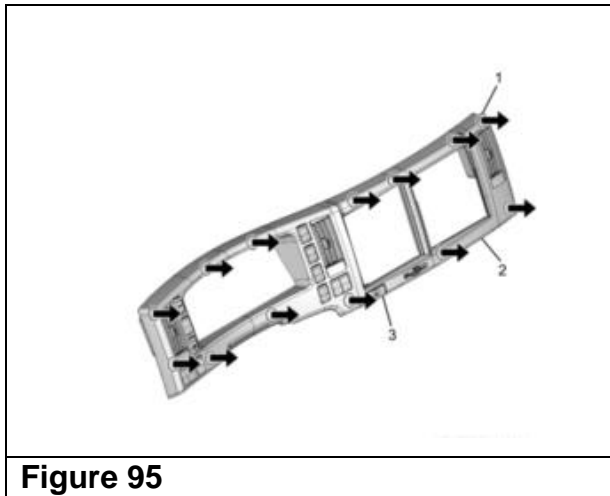
1. Bolts

100. Install the driver side instrument side cover removed in Step 47. (See Figure 94.)



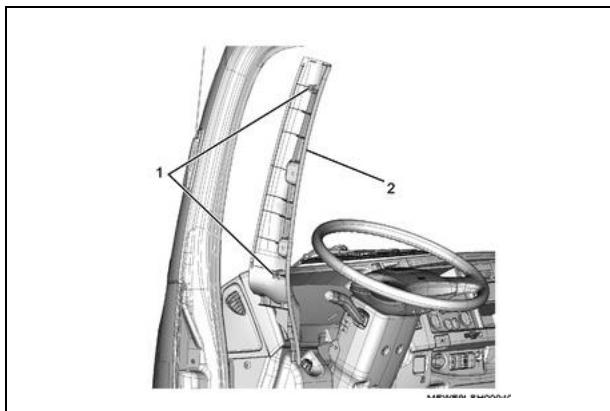
**Figure 94**

101. Place the meter cluster bezel onto the instrument panel and be sure to connect all switches. Press the meter cluster bezel back into place. (See Figure 95.)



**Figure 95**

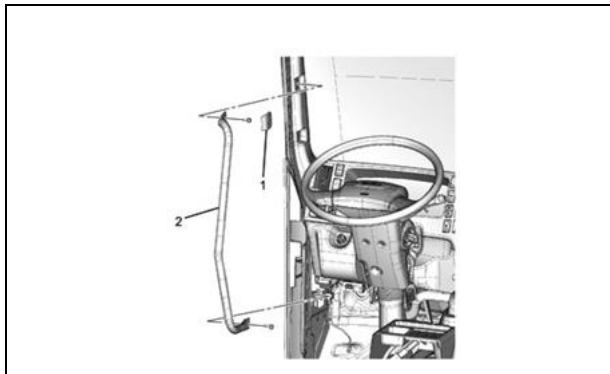
102. Install the front pillar trim cover and reinstall front door weatherstrip. (See Figure 96.)



**Figure 96**

- 1. Clips
- 2. Front Pillar Trim Cover

103. Install the assist handle to the front pillar. (See Figure 97.) Torque the mounting bolts. **Torque Specification: 19 N•m (14 lb•ft)**



**Figure 97**  
2. Assist Handle

104. Connect the negative battery cable.
105. Turn the Engine Control Switch to the “ON” position
106. Press the (+) button on the Mobileye EyeWatch display until it beeps, continue to hold the (+) button and press the (-) button on the display for ~2 seconds until the red gear appears. (See Figure 98.)
107. When the red gear appears, press (+), When the green connectors appear press (M). Move the turn signal lever turn left, and then to the right, verify double arrows appear on the display each time as shown. (See Figure 98.)
  - a. If either turn signal does not operate correctly, check wiring to ensure all connections are fully seated.
  - b. After confirming both turn signals operate correctly (i.e. the double arrows appeared in the EyeWatch display, turn the Engine Control Switch off.



**Figure 98**  
EyeWatch Display

108. Proceed to Applying the Campaign Label.

## APPLYING THE CAMPAIGN LABEL

109. Using a ball-point pen, fill in a campaign label (Part No. 2-90028-700-0) with Campaign Number 24V-157 (US) or 2024-134 (Canada), Isuzu dealer code, and repair date.
110. Affix the campaign label onto the driver's side B-pillar.



## CAMPAIGN CLAIM INFORMATION

Refer to the Isuzu ICS Claims Processing Manual for details on Campaign Claim Submission. Submit only **one claim as indicated below.**

**NOTE: Failure to submit campaign claims in a timely manner may result in non-payment. Accepted/Paid claims will change campaign status to “Closed” in IVIS. Submit claims as quickly as possible in order to close the campaign and ensure payment.**

Labor Operation Code	Description	Labor Time	Sublet Allowance
V2401	Mobileye Camera Cable Safety Recall Inspection and Cable Rerouting ADD: Harness Replacement	1.5* 0.4	\$10.00** (***)

\* Includes 0.1 hours for administrative allowance.

\*\* Reimbursement for electrical tape and zip ties provided by dealer.

\*\*\* Add \$41.00 for Mobileye harness parts markup reimbursement when the harnesses must be replaced.

## OWNER NOTIFICATION

Sample recall letters are being sent to owners of affected vehicles already retailed in the United States and Canada are attached below.

[SAMPLE OWNER LETTER – US]

## IMPORTANT SAFETY RECALL

### NHTSA Recall 24V-157

This notice applies to your vehicle, <VIN>

APRIL 2024

Dear Customer,

This notice is sent to you in accordance with the National Traffic and Motor Vehicle Safety Act.

#### WHAT IS THE CONDITION?

Isuzu Motors Limited has decided that a defect, which relates to motor vehicle safety, exists in certain 2019-2024MY F-Series vehicles equipped with RPO Code I4V Mobileye Collision Warning System. In the affected vehicles, the wiring for the Mobileye camera may have been routed incorrectly. As a result, the wiring could become damaged by contact with dash components and could overheat and melt. If this happens, the turn signals and hazard lights may not work properly, and the Mobileye collision avoidance information would not be displayed, increasing the **risk of a crash**. In addition, wiring that overheats and melts increases the **risk of a fire**.

#### WHAT WE WILL DO

Your Isuzu dealer will inspect the wiring for the damaged condition. If no problem is found, the wiring will be rerouted to remove the risk of future damage. If the wiring is damaged, it will be replaced and routed to remove the risk of future damage. This service will be performed **free of charge**.

#### WHAT YOU SHOULD DO

We recommend that you contact your Isuzu dealer to schedule an appointment. Although not necessary, please present this Owner Notification Letter at the time of your appointment or refer to Campaign Service Bulletin CB24-R-001. We estimate that the remedy may take up to 2 hours to perform. To locate the nearest Isuzu dealer, you can visit our website at [www.isuzucv.com](http://www.isuzucv.com) or contact our Customer Relations Department at the number listed below.

**Isuzu Commercial Truck of America  
Customer Relations  
1-866-441-9638**

#### REIMBURSEMENT

If you have already paid for repairs to address the condition covered by this safety recall, you may be eligible to have those costs reimbursed. The enclosed form explains the terms under which reimbursement may be available and how to request reimbursement.

If you have any difficulty having this recall performed, we recommend that you call Isuzu customer relations at 1-866-441-9638. If you are still not satisfied that we have remedied this situation without charge, and within a reasonable amount of time, you may wish to write to the Administrator of the National Highway Traffic Safety Administration, 1200 New Jersey Avenue, SE, Washington DC 20590, or call the agency's toll-free Vehicle Safety Hotline at 1-888-327-4236 (TTY: 1-800-424-9153) or go to <http://www.nhtsa.gov>.

We regret any inconvenience this action may cause you.

Sincerely,

Isuzu Commercial Truck of America, Inc.

*Important: If you have sold or traded your Isuzu vehicle, please enter the owner's name and address, if known, on the attached "Change of Information" postcard, tear off at both perforations, and drop it in the mail. Postage has already been paid. We will contact the new owner.*

*Federal law requires that any vehicle lessor receiving this recall notice must forward a copy of this notice to the lessee within ten days. Lessor means a person or entity that is the owner, as reflected on the vehicle title, of any five or more leased vehicles.*



[SAMPLE OWNER LETTER – CANADA]

## IMPORTANT SAFETY RECALL

This notice applies to your vehicle, <VIN>  
<MY> model year ISUZU F-SERIES

APRIL 2024

Dear Customer,

This notice is sent to you in accordance with the requirements of the *Motor Vehicle Safety Act*. This is to inform you that your vehicle may contain a defect that could affect the safety of a person. Safety Recall Transport Canada 2024-134.

### WHAT IS THE CONDITION?

Isuzu Motors Limited has decided that a defect, which relates to motor vehicle safety, exists in certain 2019-2024MY F-Series vehicles equipped with RPO Code I4V Mobileye Collision Warning System. In the affected vehicles, the wiring for the Mobileye camera may have been routed incorrectly. As a result, the wiring could become damaged by contact with dash components and could overheat and melt. If this happens, the turn signals and hazard lights may not work properly, and the Mobileye collision avoidance information would not be displayed, increasing the **risk of a crash**. In addition, wiring that overheats and melts increases the **risk of a fire**.

### WHAT WE WILL DO

Your Isuzu dealer will inspect the wiring for the damaged condition. If no problem is found, the wiring will be rerouted to remove the risk of future damage. If the wiring is damaged, it will be replaced and routed to remove the risk of future damage. This service will be performed **free of charge**.

### WHAT YOU SHOULD DO

We recommend that you contact your Isuzu dealer to schedule an appointment. Although not necessary, please present this Owner Notification Letter at the time of your appointment or refer to Campaign Service Bulletin CB24-R-001. We estimate that the remedy may take up to 2 hours to perform. To locate the nearest Isuzu dealer you can visit our website at [www.isuzutruck.ca](http://www.isuzutruck.ca) or contact our Customer Relations Department at the number listed below.

**Isuzu Commercial Truck of Canada**  
**Customer Relations**  
**1-866-441-9638**

### REIMBURSEMENT

If you have already paid for repairs to address the condition covered by this safety recall, you may be eligible to have those costs reimbursed. The enclosed form explains the terms under which reimbursement may be available and how to request reimbursement.

If you have questions or concerns that your Isuzu dealer is unable to answer, please contact our Customer Relations Department at 1-866-441-9638.

We regret any inconvenience this action may cause you.

Sincerely,

Isuzu Commercial Truck of Canada, Inc.

*Important: If you have sold or traded your Isuzu vehicle, please enter the owner's name and address, if known, on the attached "Change of Information" postcard, tear off at both perforations, and drop it in the mail. Postage has already been paid. We will contact the new owner.*

*Federal law requires that any vehicle lessor receiving this recall notice must forward a copy of this notice to the lessee within ten days. Lessor means a person or entity that is the owner, as reflected on the vehicle title, of any five or more leased vehicles.*

## Customer Reimbursement Claim Form

If you have paid to have this condition corrected prior to this notification, you may be eligible to receive reimbursement. Requests for reimbursement may include parts, labor, fees and taxes. Reimbursement may be limited to the amount the repair would have cost if completed by an authorized service facility.

Your claim will be acted upon within 60 days of receipt.

This section to be completed by Claimant

Date Claim Submitted: \_\_\_\_\_

17-Digit Vehicle Identification Number (VIN): \_\_\_\_\_

Mileage at Time of Repair: \_\_\_\_\_ Date of Repair: \_\_\_\_\_

Claimant Name (please print): \_\_\_\_\_

Street Address or PO Box Number: \_\_\_\_\_

City: \_\_\_\_\_ State: \_\_\_\_\_ ZIP Code: \_\_\_\_\_

Claimant Email: \_\_\_\_\_

Daytime Telephone Number (include Area Code): \_\_\_\_\_

Evening Telephone Number (include Area Code): \_\_\_\_\_

Amount of Reimbursement Requested: \$ \_\_\_\_\_

The following documentation must accompany this claim form.

Original or clear copy of all receipts, invoices, and/or repair orders that show:

- The name and address of the person who paid for the repair.
- The Vehicle Identification Number (VIN) of the vehicle that was repaired.
- What problem occurred, what repair was done, when it was done, and who did it.
- The total cost of the repair expense that is being claimed.
- Payment for the repair in question and the date of payment.  
(copy of front and back of cancelled check, or copy of credit card receipt)

My signature to this document attests that all attached documents are genuine and I request reimbursement for the expense I incurred for the repair covered by this letter.

Claimant's Signature: \_\_\_\_\_

If your claim is:

- Approved, you will receive a check,
- Denied, you will receive a letter with the reason(s) for the denial, or
- Incomplete, you will receive a letter identifying the documentation that is needed to complete the claim and offered the opportunity to resubmit the claim when the missing documentation is available.

Please mail this claim form and the required documents to:

**Isuzu Commercial Truck Customer Relations**  
**1400 S. Douglass Road, Suite 100**  
**Anaheim, CA 92806**

Reimbursement questions should be directed to the following number: 1-866-441-9638  
Or Email: [cvcs@icta-us.com](mailto:cvcs@icta-us.com)