

TECHNICAL INSTRUCTIONS

FOR

SAFETY RECALL - 24TA05

POTENTIAL AXLE SHAFT SEPARATION

CERTAIN 2022-2023 TACOMA

Updated

07/12/2024 – Added supersession part number for rear differential fluid
06/03/2024 – Clarified required parts for rear axle housing bolt replacement

The repair quality of covered vehicles is extremely important to Toyota. All dealership technicians performing this repair are required to successfully complete the most current version of the E-Learning course “Safety Recall and Service Campaign Essentials”. To ensure that all vehicles have the repair performed correctly; technicians performing this repair are required to have currently completed the following courses:

- T4535 – Steering, Suspension & Handling

Always check which technicians can perform the repair by logging on to <https://www.uotdealerreports.com>. It is the dealership’s responsibility to select technicians with the above certification level or greater to perform this repair. Carefully review your resources, the technician’s skill level, and ability before assigning technicians to this repair. It is important to consider technician days off and vacation schedules to ensure there are properly trained technicians available to perform this repair at all times.

I. OPERATION FLOW CHART

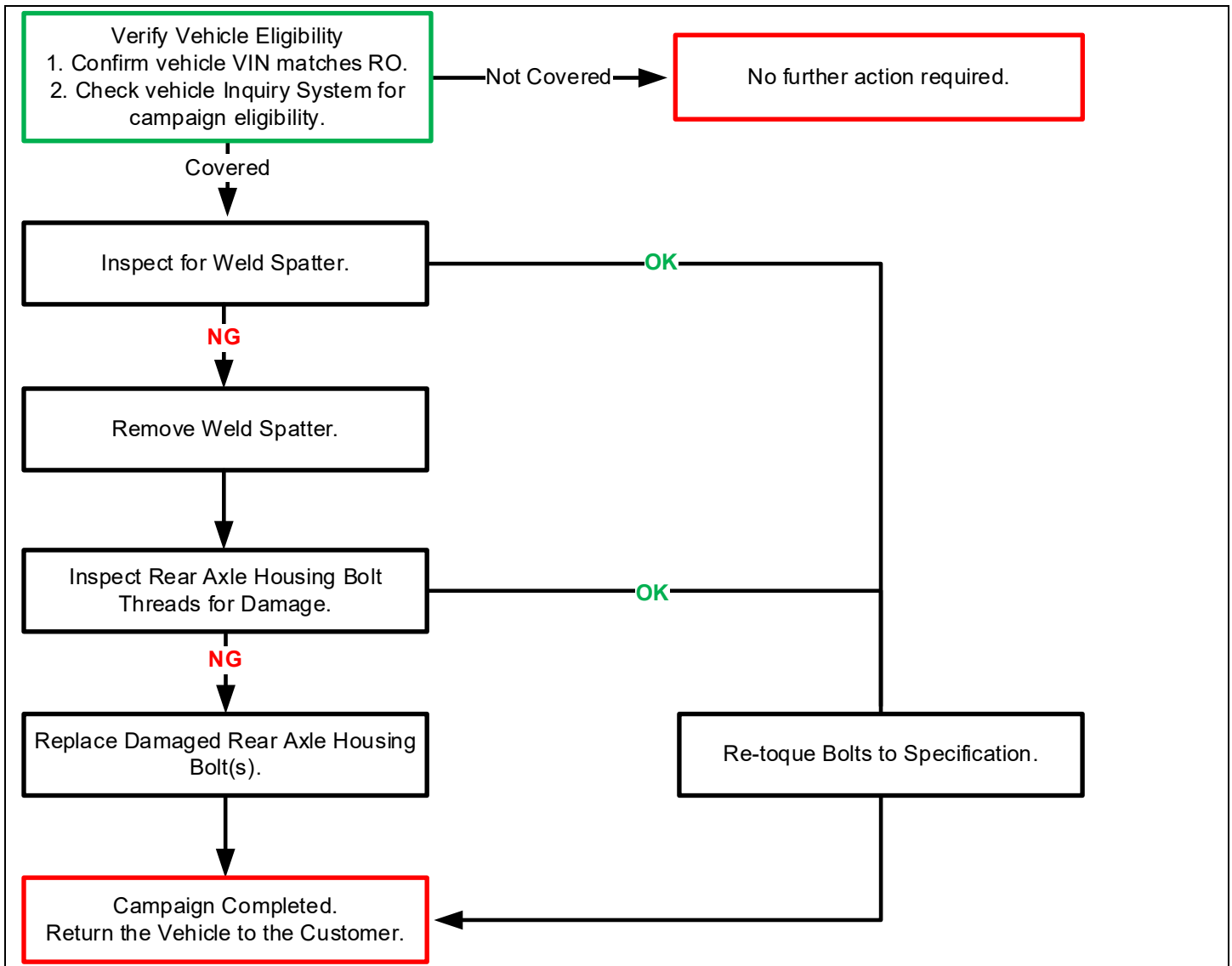

II. IDENTIFICATION OF AFFECTED VEHICLES

1. CHECK VEHICLE FOR CAMPAIGN ELIGIBILITY

- Compare the vehicle's VIN to the VIN listed on the Repair Order to ensure they match.
- Check the TIS Vehicle Inquiry System to confirm the VIN is involved in this Campaign, and that it has not already been completed.

NOTE: TMNA warranty will not reimburse dealers for repairs completed on vehicles that are not affected or were previously completed, even by another dealer.

III. PREPARATION

A. PARTS

Standard Repair

Part Number	Part Description	Quantity
90178-A0052	Nut (shipped to dealers in bags of 10 nuts) *Use as needed per vehicle.	1-8*

*Only nuts where weld splatter is found will require replacement.

If Damage to Axle Housing Bolt Threads Exists (Use only if damage to rear axle housing bolt exists and opcode 24TA05R3 is being claimed)

Part Number	Part Description	Quantity
90114-A0009	Rear Axle Housing Bolt	1-8
42450-04010	Right Rear Hub and Bearing Assembly	0-1*
42460-04010	Left Rear Hub and Bearing Assembly	0-1*
00475-1BF03	Brake Fluid	As needed (max 2)
42423-60050	Rear Axle Bearing Inner Retainer	1-2
90520-41019	Rear Axle Shaft Snap Ring	1-2
90301-83002	O-Ring	1-2
90310-58003	Rear Axle Shaft Oil Seal	1-2
0885-02906 (Supersedes 08885-02506)	Rear Differential Fluid - Toyota Genuine Differential gear oil LT 75W-85 APL GL-5 or equivalent	As needed (max 4 US qts.)

*Hub and bearing assembly **MUST** be replaced when replacing damaged rear axle housing bolt. Order hub bearing assembly that corresponds to the side of the axle assembly with the damaged rear axle housing bolt.

B. TOOLS & EQUIPMENT

• Techstream or GTS+	• Standard Hand Tools	• Torque Wrench
• Cold Chisel - Flat	• Flat File	• Vinyl tape
• Red Paint Marker		

C. MATERIALS

• Brake Cleaner	• Protective Glasses	• Rags
• Protective Gloves		

IV. WORK PROCEDURE TABLE OF CONTENTS

BACKGROUND.....	SECTION V.
COMPONENTS	SECTION VI.
WELD SPATTER AXLE NUT INSPECTION AND REPAIR PROCEDURE	SECTION VII.
DETERMINE PROPER REPAIR PROCEDURE	SECTION VIII.
REAR AXLE HOUSING BOLT REPAIR PROCEDURE.....	SECTION IX.
APPENDIX	SECTION X.

V. BACKGROUND

Welding debris left on the ends of the rear axle assembly during manufacturing could cause certain retaining nuts to loosen over time and eventually fall off, potentially causing a part to separate from the axle. If separation occurs, this can affect vehicle stability and brake performance, increasing the risk of a crash.

VI. COMPONENTS

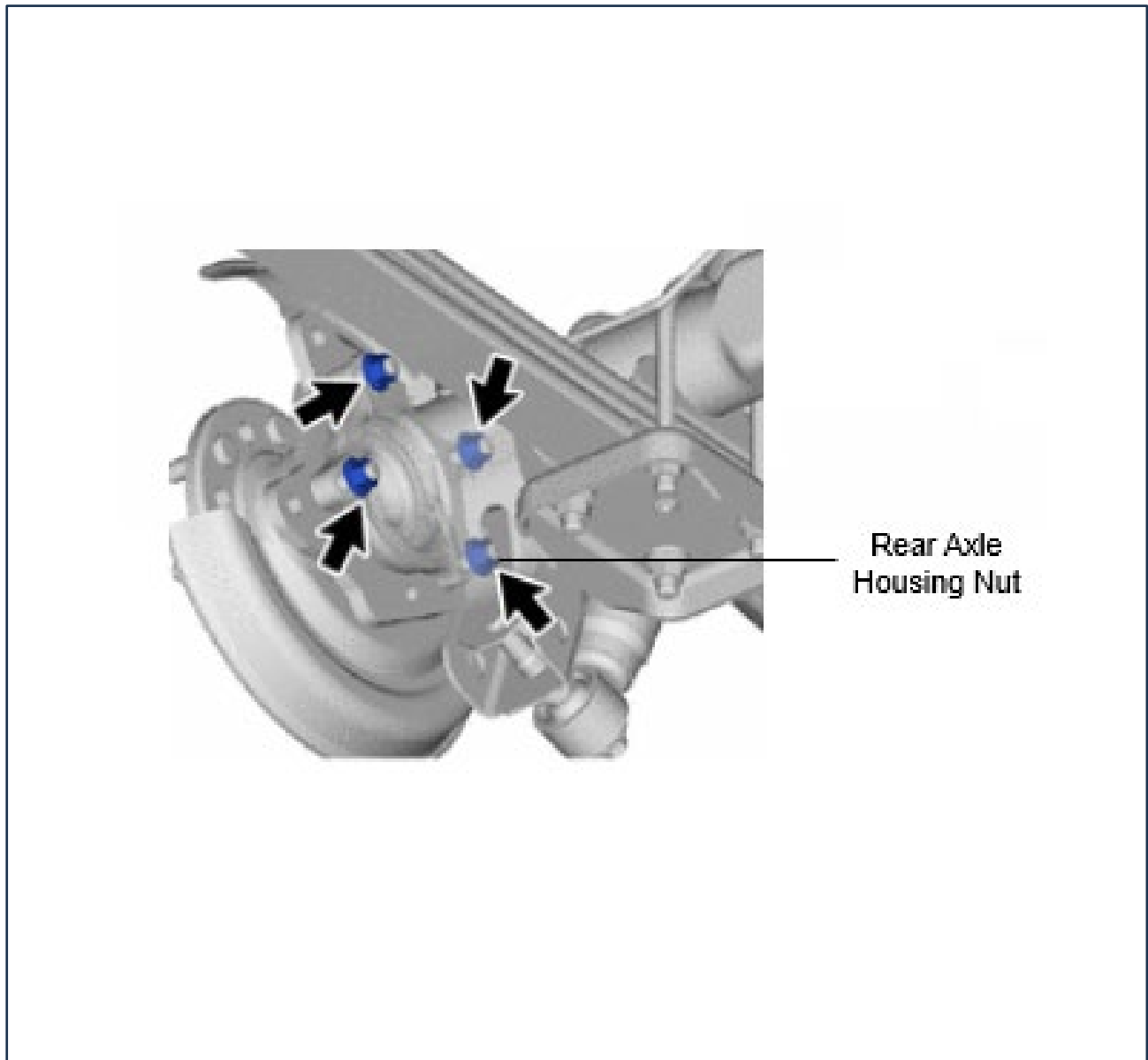

VII. WELD SPATTER - AXLE NUT INSPECTION AND REPAIR PROCEDURE



1. CHECK FOR DTCs

- Using Techstream /GTS+, check for Diagnostic Trouble Codes.



If any DTCs are found that indicate a safety risk at performing this repair, do not proceed until they have been resolved.

NOTE: This Safety Recall covers only the installation of the rear axle housing nuts or bolts, as detailed in these instructions. It does not cover the diagnosis or replacement of any other parts of the vehicle.

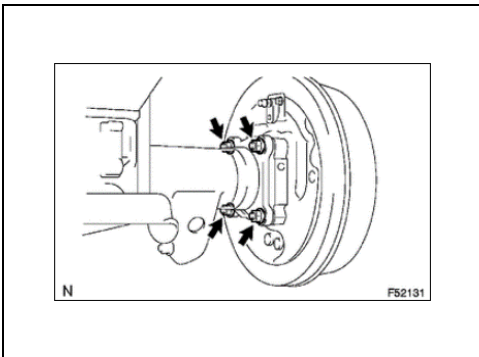

2. LOCATION OF AXLE NUTS

- Start by locating the rear axle housing nuts.

NOTE: The rear axle housing nuts will be inspected one at a time to ensure no damage or warping to axle housing occurs.

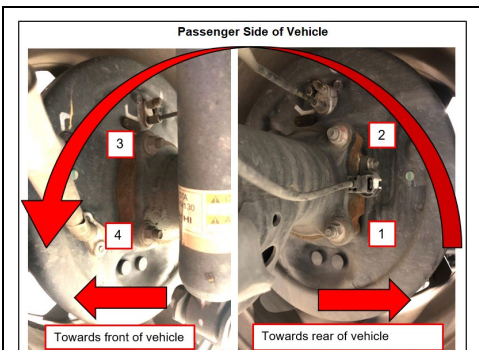

- Inspection and repair of passenger side rear axle housing nuts.

- Passenger side axle nuts are identified in the corresponding illustration (1 – 4).

HINT: When inspecting the passenger side, the rear shock absorber is on the axle tube's front side.

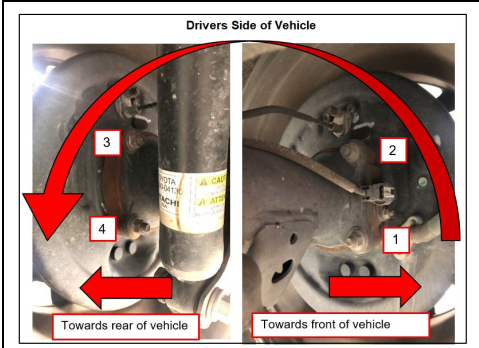

- Inspection and repair of driver side rear axle housing nuts.

- Driver side axle nuts are identified in the corresponding illustration (1 – 4).

HINT: When inspecting the driver side, the rear shock absorber is on the axle tube's rearward side.

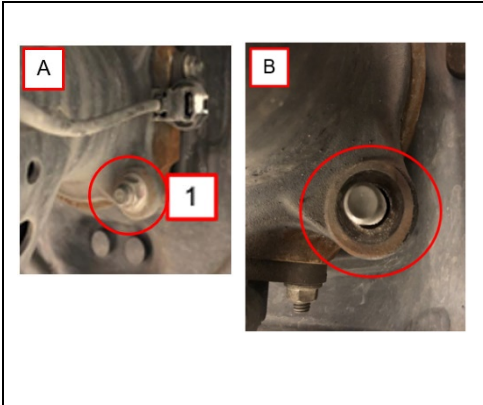

3. BEGIN INSPECTION OF PASSENGER SIDE AXLE HOUSING NUTS

a. Remove and inspect nut #1.

- A.** Locate the passenger side nut #1 as shown in the illustration.
- B.** Remove the passenger side #1 nut.

NOTE: The area to inspect is the axle nut contact surface on the axle flange.

b. Inspect the rear axle housing bolt for damage to its threads.

Is there any damage to the axle housing bolt threads?

NO: Proceed to step c.

YES: Mark the flange with a red "X" near the rear axle housing bolt with the damaged threads. Then proceed to step c.

NOTE: Flanges marked with a red "X" will require the replacement of the rear axle housing bolt in Section IX.



c. Carefully inspect the flat surface behind the axle nut to ensure the area is free of any weld spatter.

HINT: See examples of the "OK" condition vs. "NG" weld spatter condition in the corresponding illustration.

Does any weld spatter exist?

OK: Re-install axle nut and torque to specification.

NG: Proceed to Step 4.

Torque:

55 N·m {41 ft·lbf}





4. REMOVE WELD SPATTER

- a. Install spare vinyl tubing or tape to protect the rear axle housing bolt threads.



- b. Using a cold chisel, remove the weld spatter by carefully striking the weld spatter with the chisel.
- c. Any weld spatter that cannot be removed using a chisel will be removed using a file.

HINT: Use a hard flat file to remove any remaining weld spatter that could not be removed by using a chisel.

NOTICE: Use Extreme Caution to avoid altering the flange surface beyond removing the weld spatter



5. VERIFY REAR AXLE HOUSING BOLT FLANGE IS CLEAR OF WELD SPATTER

- a. Check the surface for smoothness (any abnormalities/bumps should be removed using a chisel/file).
- b. Check visually for surface gouges.
- c. Assure a flat surface is maintained.



6. INSTALL NEW REAR AXLE HOUSING NUT

- a. Install a NEW rear axle housing nut to the location that was just repaired.
- b. Torque the nut to specification.

Torque:
55 N·m {41 ft·lbf}

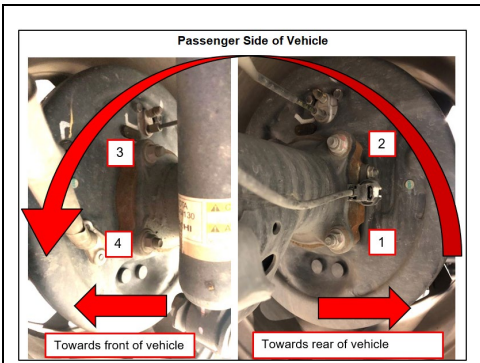

7. REPEAT STEPS FOR REMAINING NUTS

- a. Repeat steps 3 – 8 for nut location #'s (2 – 4).
- b. Be sure to only inspect and repair one nut at a time, and ensure each nut is torqued to specification before moving to the next nut. If this is not followed, damage to the axle housing could occur.
- c. Be sure to mark housing if any damaged bolt threads are discovered during inspection.

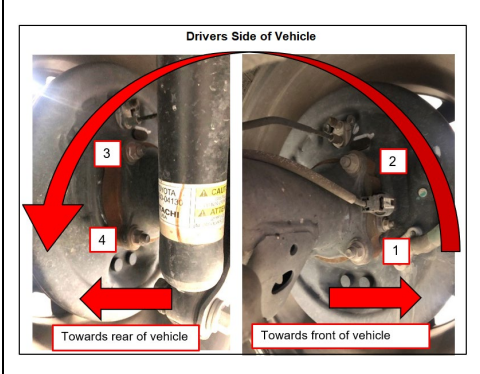

8. BEGIN INSPECTION OF DRIVER SIDE AXLE HOUSING NUTS

- a. Repeat steps 3 – 7 for driver side nut location #'s (1 – 4).
- b. Be sure to only inspect and repair one nut at a time, and ensure each nut is torqued to specification before moving to the next nut. If this is not followed, damage to the axle housing could occur.
- c. Be sure to mark housing if any damaged bolt threads are discovered during inspection.

VIII. DETERMINE THE PROPER REPAIR PROCEDURE

Follow the flow below to determine which repair needs to be completed.

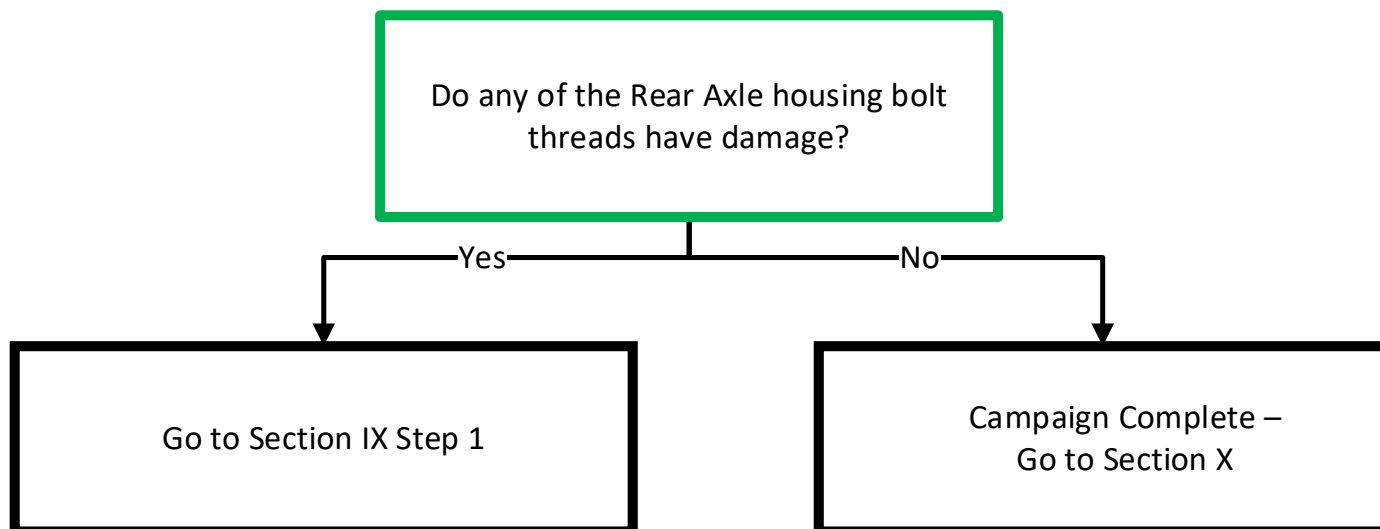

IX. REAR AXLE HOUSING BOLT REPAIR PROCEDURE

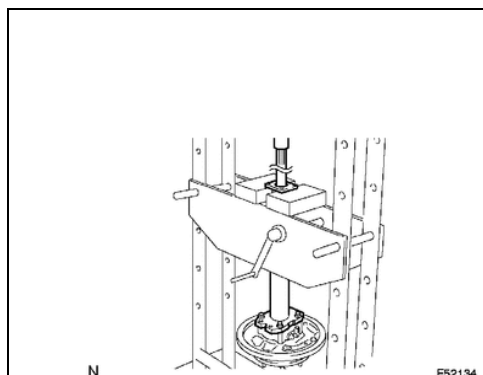

1. FOLLOW THE APPROPRIATE REPAIR MANUAL SECTION FOR REPLACING REAR AXLE HOUSING BOLT(S)

- a. [Removal](#): AXLE: REAR AXLE SHAFT: REMOVAL; 2018 - 2023 MY Tacoma
- b. [Disassembly](#): AXLE: REAR AXLE SHAFT: DISASSEMBLY; 2016 - 2023 MY Tacoma
- c. [Reassembly](#): AXLE: REAR AXLE SHAFT: REASSEMBLY; 2016 - 2023 MY Tacoma
- d. [Installation](#): AXLE: REAR AXLE SHAFT: INSTALLATION; 2018 - 2023 MY Tacoma

NOTE: Be sure to remove all red "X" marks from the rear axle housing flange upon completion of all repairs.



2. CHECK FOR DTCs

- a. Using Techstream / GTS+, check for Diagnostic Trouble Codes.

NOTE: This Safety Recall covers only the installation of the rear axle housing nuts or bolts, as detailed in these instructions. It does not cover the diagnosis or replacement of any other parts of the vehicle.

◀ VERIFY REPAIR QUALITY ▶

- Confirm any rear axle housing nuts are installed exactly as instructed.
- Confirm all rear axle housing bolts are installed exactly as instructed (if applicable).
- Confirm proper torque specification is applied to all rear axle housing nuts.
- Confirm no brake fluid leaks are present after completing the repair (if applicable).
- If you have any questions regarding this update, please contact your area representative.

X. APPENDIX

A. PARTS DISPOSAL

As required by Federal Regulations, please make sure all recalled parts (original parts) removed from the vehicle are disposed of in a manner in which they will not be reused, ***unless requested for parts recovery return.***

B. CAMPAIGN DESIGNATION DECODER

