

**TECHNICAL INSTRUCTIONS**

**FOR**

**SPECIAL SERVICE CAMPAIGN 24TA04**

**REAR SEAT HEAD REST PERFORMANCE**

**CERTAIN 2023-2024 MODEL YEAR CAMRY AND CAMRY HV**

The repair quality of covered vehicles is extremely important to Toyota. All dealership technicians performing this recall are required to successfully complete the most current version of the E-Learning course "Safety Recall and Service Campaign Essentials". To ensure that all vehicles have the repair performed correctly; technicians performing this repair are required to currently have completed all the following courses:

- TIC206A - Electrical Repair 1

Always check which technicians can perform the repair by logging on to <https://www.uotdealerreports.com>. It is the dealership's responsibility to select technicians with the above certification level or greater to perform this repair. Carefully review your resources, the technician's skill level, and ability before assigning technicians to this repair. It is important to consider technician days off and vacation schedules to ensure there are properly trained technicians available to perform this repair at all times.

# OPERATION FLOW CHART

The flowchart is for reference only. DO NOT use it in place of the full technical instructions. Follow ALL steps as outlined in the full technical instructions to confirm the campaign is completed correctly.

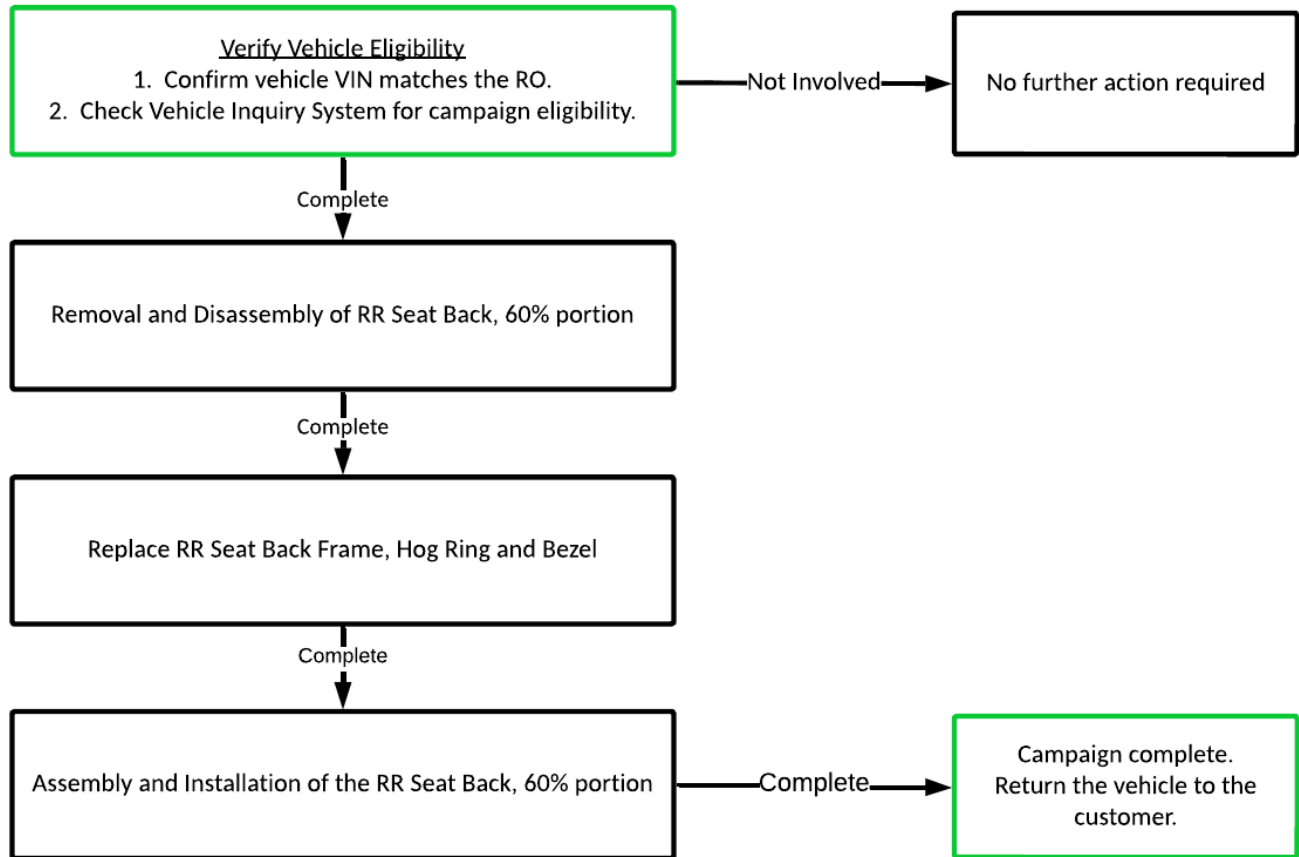

## I. IDENTIFICATION OF AFFECTED VEHICLES

### 1. CHECK VEHICLE FOR CAMPAIGN ELIGIBILITY

- a. Compare the vehicle's VIN to the VIN listed on the Repair Order to ensure they match.
- b. Check the TIS Vehicle Inquiry System to confirm the VIN is involved in this Campaign, and that it has not already been completed.

**NOTE: TMNA warranty will not reimburse dealers for repairs completed on vehicles that are not affected or were previously completed, even by another dealer.**

## II. PREPARATION

### A. PARTS

#### XLE, XSE and Standard Grades

Part Number	Description	Quantity
71017-06210	FRAME SUB-ASSY, RR SEAT BACK, RH	1
72667-06060-C0	BEZEL, RR SEAT BACK LOCK, UPR	1
90468-16019	HOG RING	1

#### LE, SE and Nightshade Grades

Part Number	Description	Quantity
71017-06420	FRAME SUB-ASSY, RR SEAT BACK, RH	1
72667-06060-C0	BEZEL, RR SEAT BACK LOCK, UPR	1
90468-16019	HOG RING	1

### B. TOOLS & EQUIPMENT

- Standard hand tools

## III. WORK PROCEDURE TABLE OF CONTENTS

BACKGROUND .....	SECTION IV.
COMPONENTS .....	SECTION V.
REPLACE RR SEAT BACK FRAME .....	SECTION VI.
APPENDIX .....	SECTION VII.

## IV. BACKGROUND

The two head restraints on the 60% portion of the rear, fold down seats in the involved vehicles may have poor welds on a bracket that can cause the vehicles not to comply with a federal safety standard. This can affect head restraint performance and increase the risk of injury during certain collisions.

## V. COMPONENTS

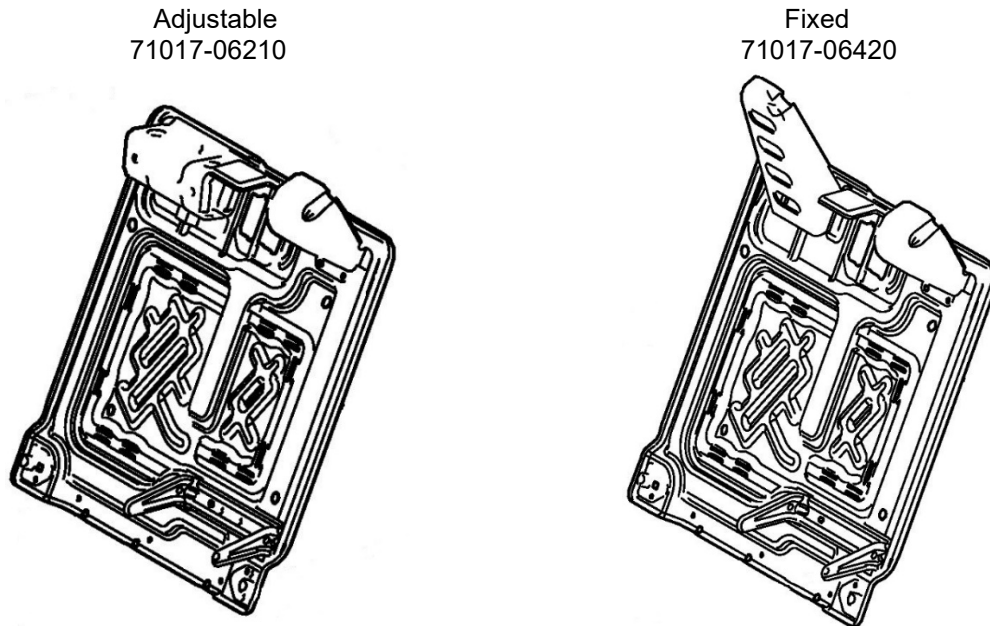

## VI. REPLACE RR SEAT BACK FRAME

1. Removal and disassembly of the RR Seat Back
  - a. [REMOVAL; 2021 - 2024 MY Camry](#)
  - b. [DISASSEMBLY; 2018 - 2024 MY Camry](#)
2. Mark the old seat back frame, Hog ring, and Bezel so as not to reinstall by accident.
3. Replace RR Seat Back Frame, Hog ring, and Bezel with new parts.
4. Assembly and Installation of the RR Seat Back
  - a. [REASSEMBLY; 2018 - 2024 MY Camry](#)
  - b. [INSTALLATION; 2018 - 2024 MY Camry](#)

### ◀ VERIFY REPAIR QUALITY ▶

- Confirm quality of the repair by verifying the marking on the old seat back frame. If the marking is present, it ensures that the old part has not been reinstalled accidentally.
- If you have any questions regarding this Campaign, please contact your regional representative.

## VIII. APPENDIX

### A. PARTS DISPOSAL

As required by Federal Regulations, please make sure all recalled parts (original parts) removed from the vehicle are disposed of in a manner in which they will not be reused, ***unless requested for parts recovery return.***

## B. CAMPAIGN DESIGNATION DECODER

