

February 28, 2024

Version 3

Safety Recall: 2024 RDX EPS Gearbox Assembly

Supersedes 24-003 dated February 28, 2024, to revise the information highlighted in **yellow**.

AFFECTED VEHICLES

Year	Model	Trim Level	VIN Range
2024	RDX	ALL	Check iN VIN status for eligibility

REVISION SUMMARY

Under WARRANTY CLAIM INFORMATION, a claim filing instruction has been added.

BACKGROUND

Due to a manufacturing error, a very small number of vehicles may have been produced with improperly fastened bolts in the electronic power steering (EPS) gearbox assemblies. An improperly fastened bolt may allow moisture to enter the assembly and over time cause the steering gearbox to lock up. Improperly manufactured EPS gearbox assemblies may affect steering function, potentially increasing the risk of a crash or injury.

CLIENT NOTIFICATION

Owners of affected vehicles will be sent a notification of this campaign.

Do an iN VIN status inquiry to make sure the vehicle is shown as eligible.

Some vehicles affected by this campaign may be in your new or used vehicle inventory.

Failure to repair a vehicle subject to a recall or campaign may subject your dealership to claims or lawsuits from the client or anyone else harmed as a result of such failure. To see if a vehicle in inventory is affected by this safety recall, do a VIN status inquiry before selling it.

CORRECTIVE ACTION

If the VIN is eligible, replace the EPS gearbox.

CLIENT INFORMATION: The information in this bulletin is intended for use only by skilled technicians who have the proper tools, equipment, and training to correctly and safely maintain your vehicle. These procedures should not be attempted by “do-it-yourselfers,” and you should not assume this bulletin applies to your vehicle, or that your vehicle has the condition described. To determine whether this information applies, contact an authorized Acura automobile dealer.

PARTS INFORMATION

To obtain the correct parts for each vehicle repair, **contact your local parts analyst** with the vehicle's VIN, the Power Steering Rack Assembly part number, and this service bulletin number. The parts center will order the correct parts on behalf of your dealer after the eligibility of the VIN is confirmed.

Steering Rack Part Numbers (needed when calling parts center)

Part Name	Part Number	Quantity
Power Steering Rack Assembly (BASE/TECH AWD)	53623-TJB-A01	1
Power Steering Rack Assembly (ADV SH AWD)	53623-TJB-A70	1
Power Steering Rack Assembly (ASPEC SH-AWD)	53623-TJB-A60	1
Power Steering Rack Assembly (ASPEC PMC, ASPEC SH-AWD ADVANCE)	53623-TJB-A80	1

Parts included in each kit:

Part Name	Quantity
Power Steering Rack Assembly	1
Gearbox Mounting Bolt (14X72)	1
Gearbox Mounting Bolt	2
Flange Nut (12MM)	2
Split Pin (3.0X22)	2
Flange Bolt (14X90)	4
Flange Bolt (14X79)	2
Self-Lock Nut (12MM)	6
Flange Bolt (14X50)	2
Flange Nut (10MM)	2
Pre Chamber Gasket	2
Flange Bolt (12X35)	2
Flange Bolt (14X105)	1
Flange Bolt (12X33)	3
Self-Lock Nut (10MM)	6

TOOL INFORMATION

Tool Name	Tool Number	Quantity
Subframe Adapter	VSB02C000016	1
Subframe Alignment Pin	070AG-SJAA10S	1
Ball Joint Thread Protector	071AF-TZ3A100	1
Ball Joint Remover	07MAC-SL00102	1

WARRANTY CLAIM INFORMATION

Please enter the EPS Gearbox replacement part number under template A.

Operation Number	Description	Flat Rate Time	Defect Code	Symptom Code	Template ID	Failed Part Number
5131L8	Replace EPS Gearbox (includes alignment)	1.5	6GZ00	FHT00	B24003A	53623-TJB-A01

Skill Level: Repair Technician

REPAIR PROCEDURE

1. Disconnect the negative terminal of the 12-volt battery.

NOTE:

- With the driver's door open, turn the vehicle to the OFF (LOCK) mode, wait at least 3 minutes before disconnecting the 12-volt negative battery cable.
- To protect the 12-volt battery sensor connector from damage, do not hold it when removing the terminal.
- Do not disconnect the 12-volt battery sensor from the cable.

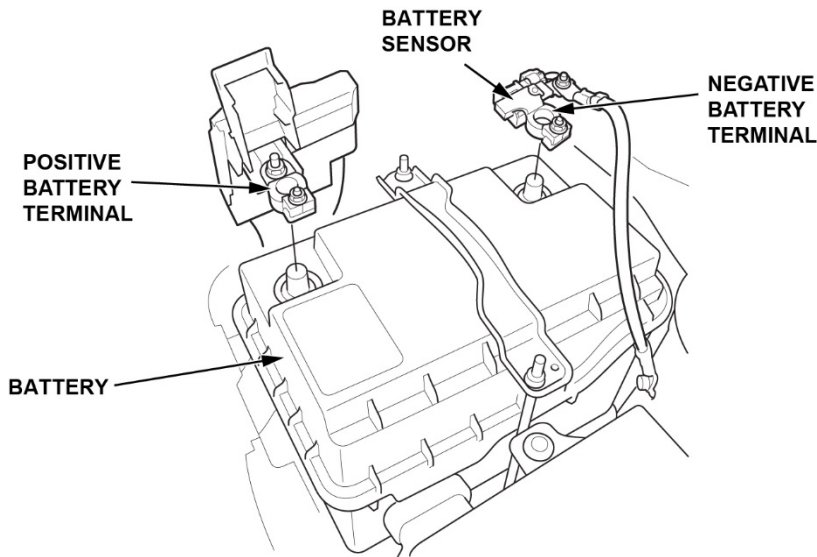

2. Disconnect the steering joint.

- Set the steering column to the down tilt position, and the long telescope position.
- If the center guide is in place and has not moved, leave it in place.
- If the center guide has come off, discard it.

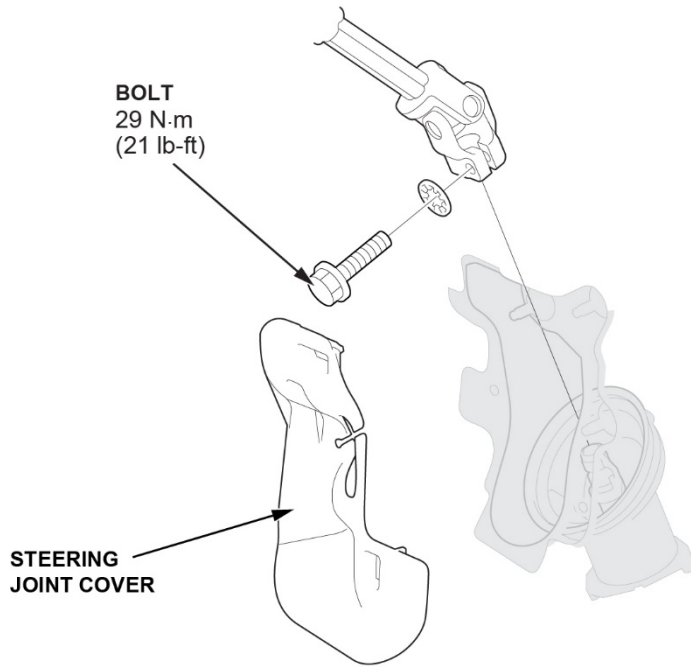

3. Lift the vehicle.

4. Remove the front wheels.

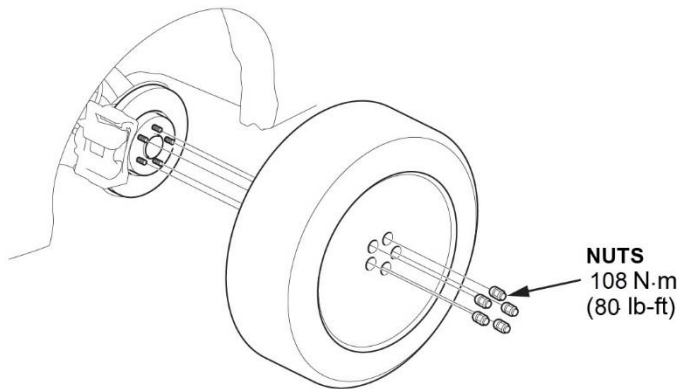

5. Remove the front engine undercover.

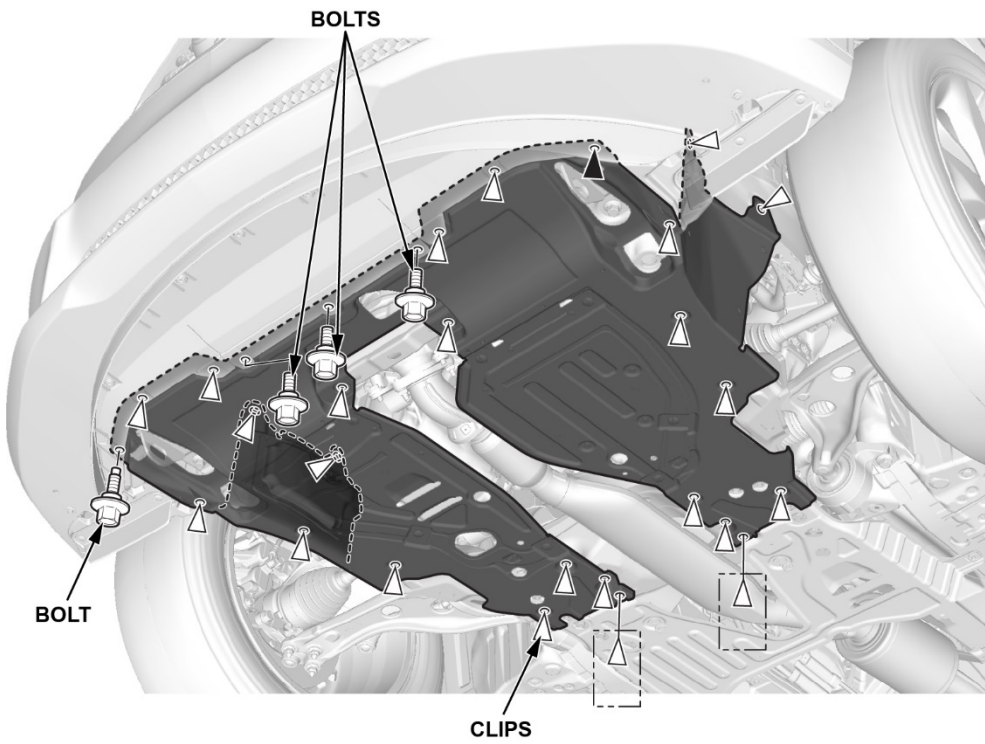

6. Remove the rear engine undercover.

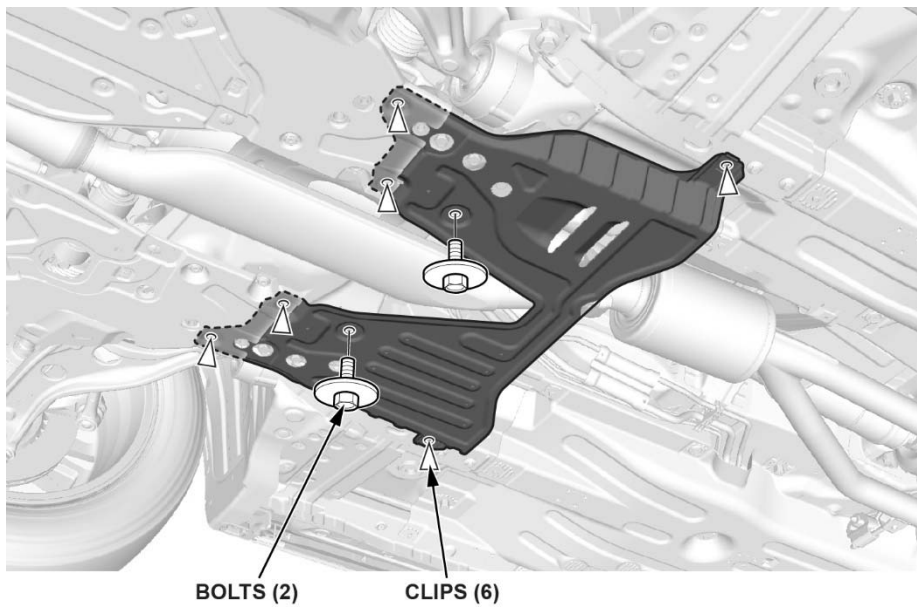

7. Remove the exhaust A-pipe.

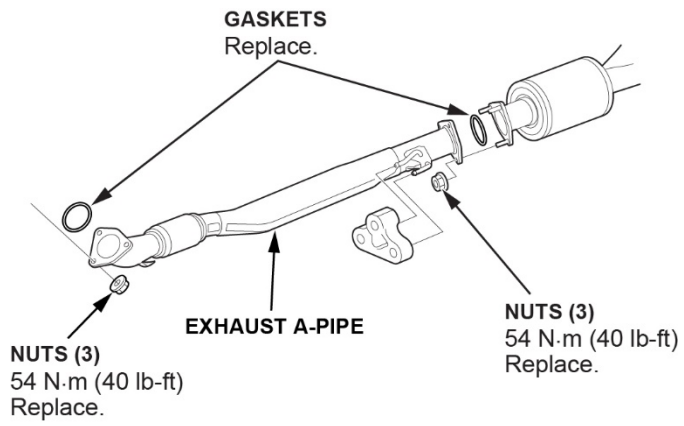

8. Disconnect the lower arm from the ball joint (both sides).

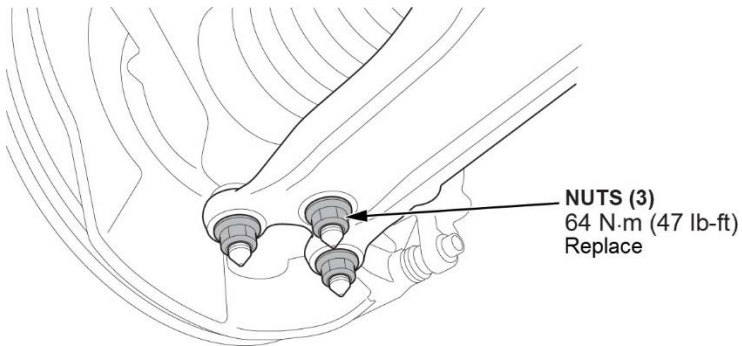

9. Disconnect the lower stabilizer link joint (both sides).

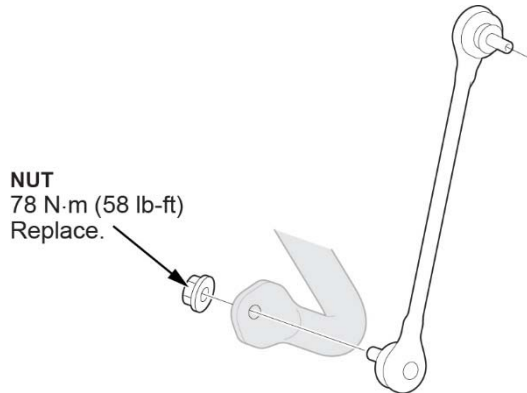

10. Disconnect the tie rod end from the steering knuckle (both sides).

NOTE: Be careful not to damage the boot when removing and installing.

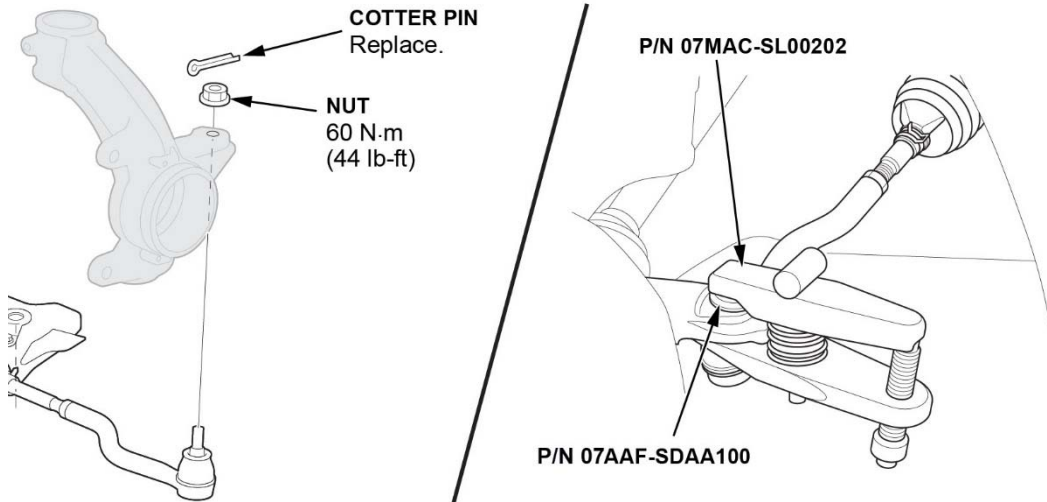

11. Disconnect the EPS connector by pushing in on the lock tab, then pull the lock lever away from the connector to release it, as shown in the numbered sequence. Once released, the connector can be separated.

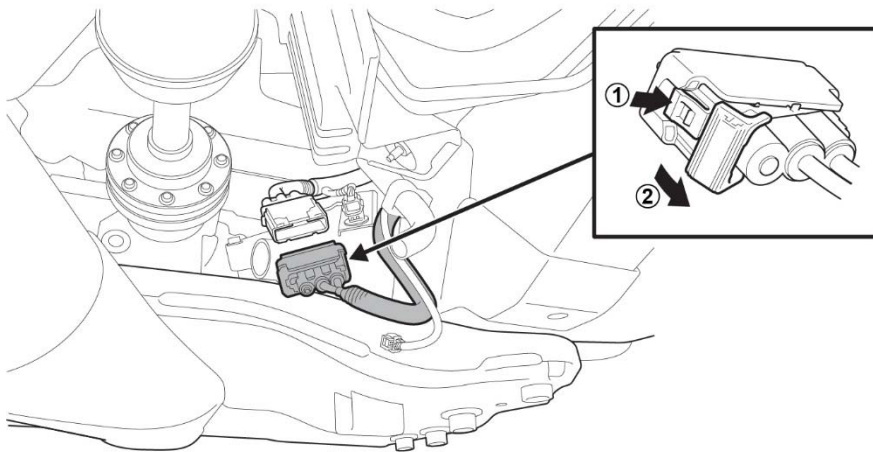

12. Remove the compliance bushing bolt that secures the compliance bushing to the chassis (both sides).

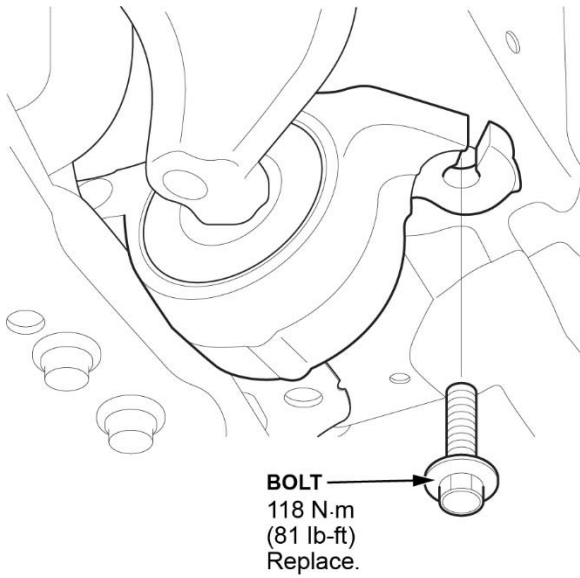

13. Remove the lower torque rod bolts (leave the torque rod attached to the subframe).

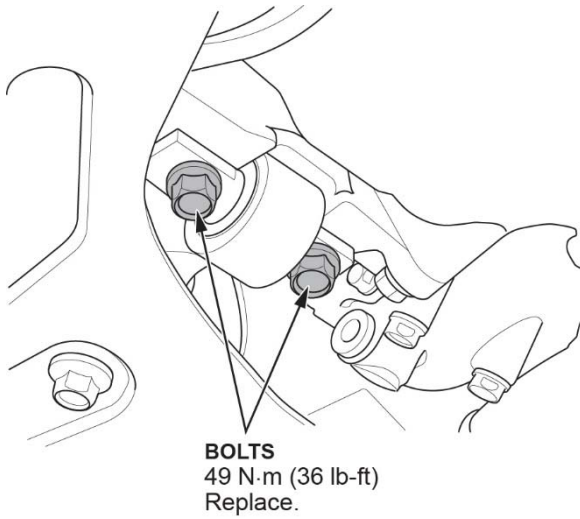

14. Attach the subframe adapter to support the front subframe.

- Loop the belt over the front of the front subframe and secure the belt with its stop, then tighten the wing nut.
- Raise a transmission jack and line up the slots in the subframe adapter arms with the bolt holes on the transmission jack base, then securely attach them with four bolts.

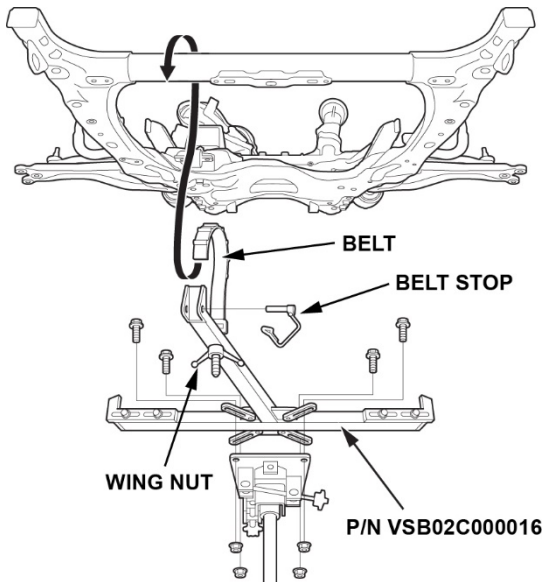

15. Remove the front subframe bolts, then lower the subframe assembly.

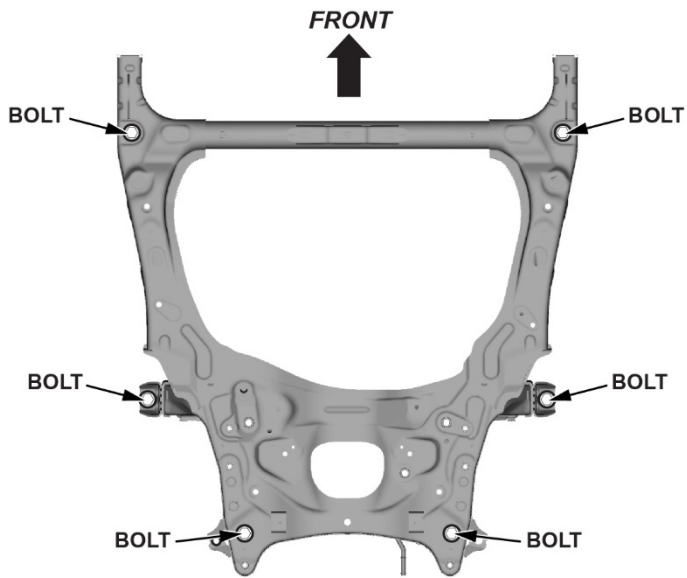

16. Transfer the EPS wiring harness to the new steering gearbox.

NOTE: Do not remove the torque sensor harness (the smaller harness connected to the EPS Motor/Control unit).

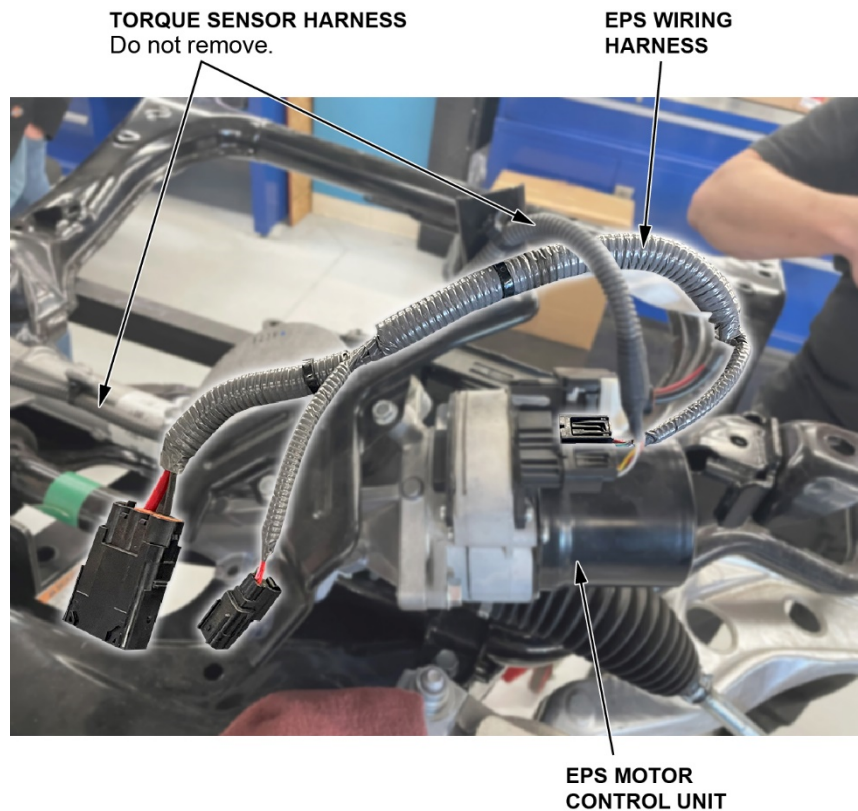

17. Remove the tie rod ends from the steering gearbox.

NOTE: Count the number of turns used when removing the tie rod ends.

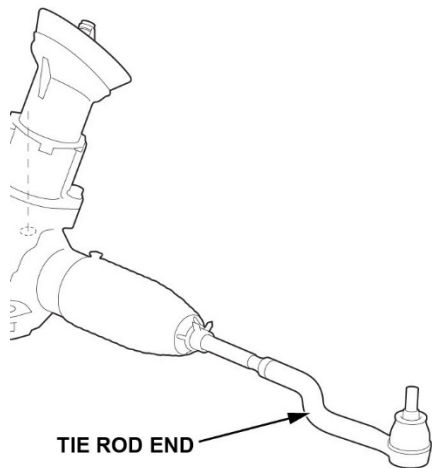

18. Remove the steering gearbox mounting bolts.

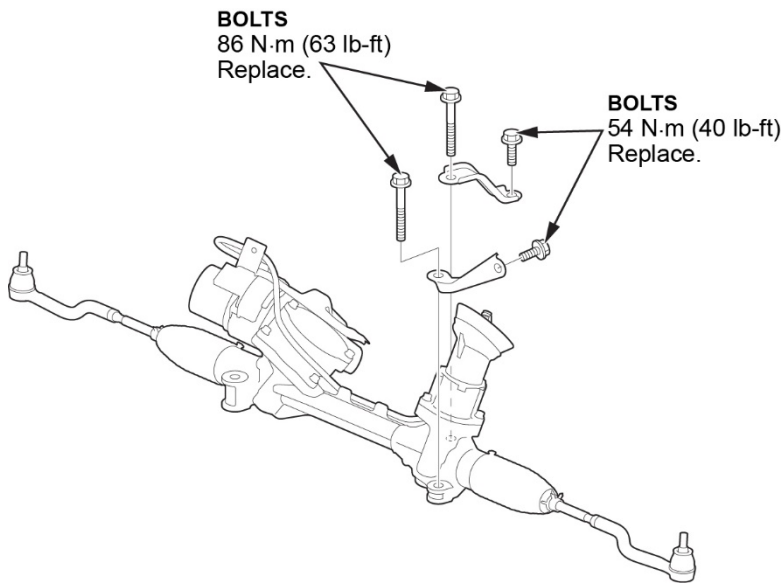

19. Install the new steering gearbox to the front subframe and loosely install the mounting bolts.

20. Torque the steering gearbox mounting bolts to specification using the sequence below:

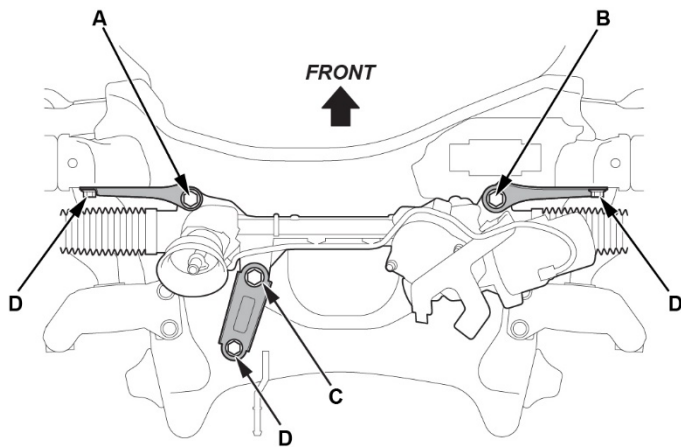

Procedure		Item
1	Loosely install	All bolts (a, b, c, d)
2	Torque to 86 N·m (63 lb-ft)	Bolt a
3	Torque to 86 N·m (63 lb-ft)	Bolt b
4	Torque to 86 N·m (63 lb-ft)	Bolt c
5	Torque to 54 N·m (40 lb-ft)	Bolts d

21. Install the tie rod ends to the steering gearbox using the same number of turns you counted when removing.

NOTE: The final torque of the lock nut will be done during the wheel alignment.

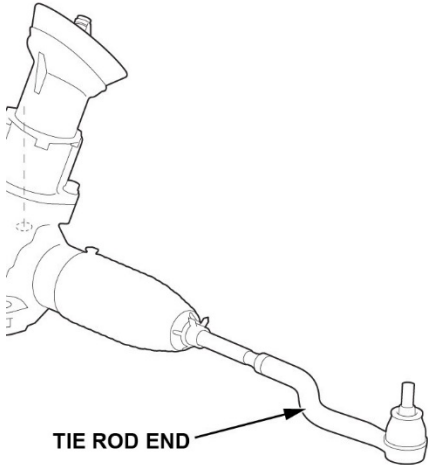

22. Install the EPS wiring harness.

TORQUE SENSOR HARNESS
Do not remove.

EPS WIRING HARNESS

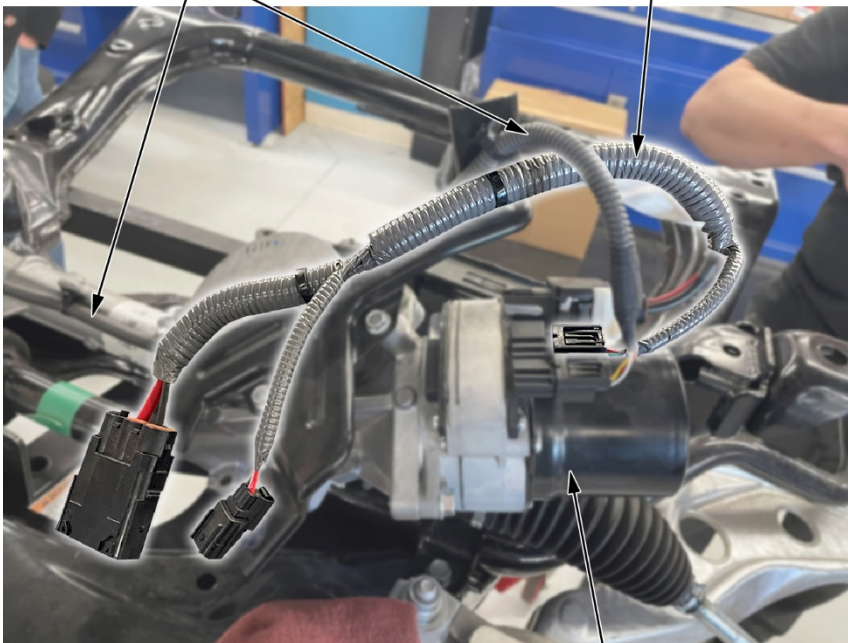

EPS MOTOR CONTROL UNIT

23. Install the front subframe and loosely install the new subframe mounting bolts.
24. Align the subframe using the alignment pin to properly position the subframe, then tighten the subframe bolts to specification.

Procedure		Item
1	Loosely install	All bolts (A,B)
2	Align	Subframe
3	Tighten to 103 N·m (76 lb-ft)	Bolts (A)
4	Tighten to 98 N·m (72 lb-ft)	Bolts (B)

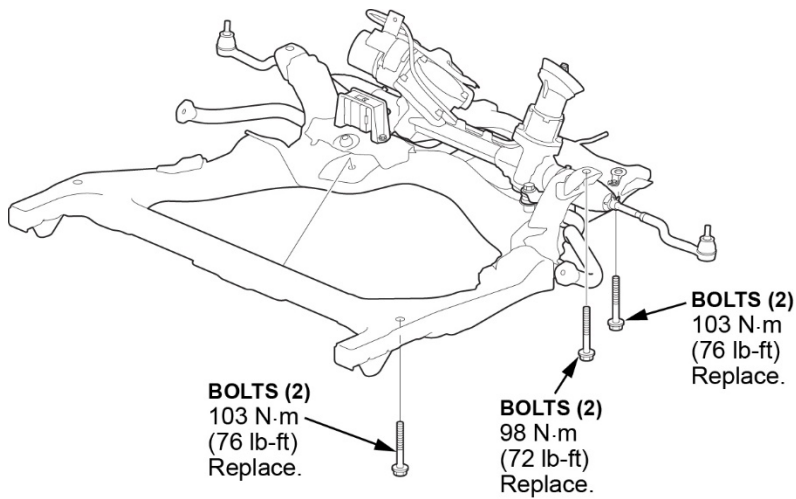
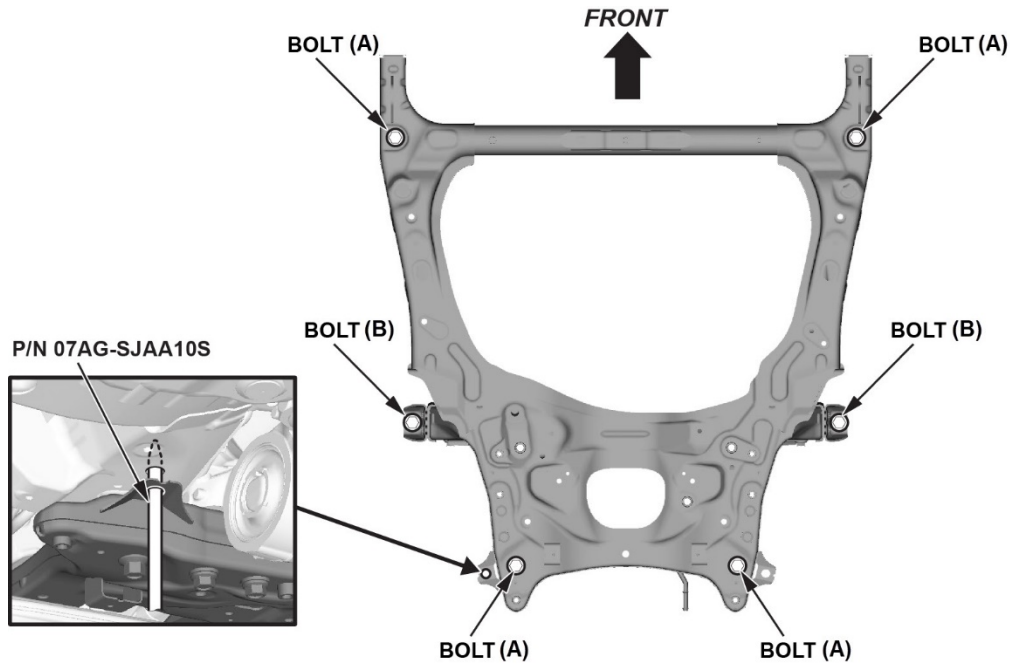

25. Install the torque rod mounting bolts.

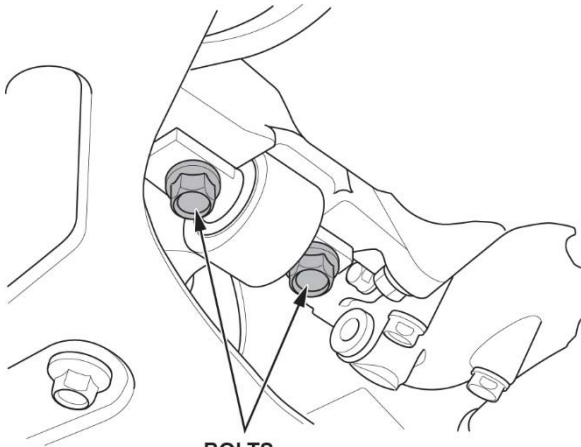

BOLTS
49 N·m (36 lb-ft)
Replace.

26. Install the compliance bushing bolt (both sides).

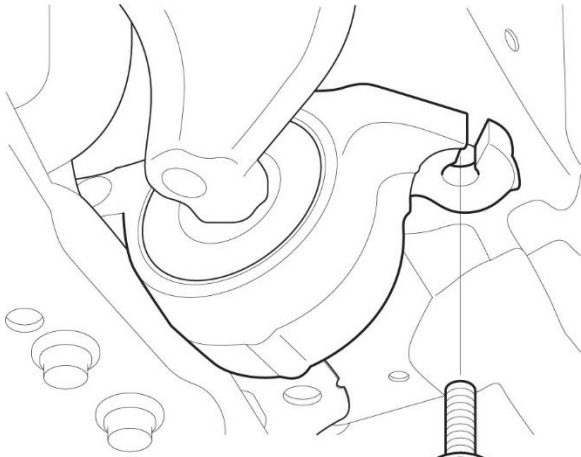

BOLT
118 N·m
(87 lb-ft)
Replace.

27. Reattach the tie rod end to the steering (both sides).

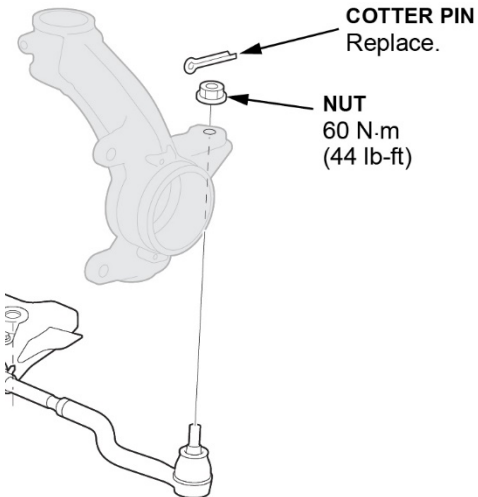

COTTER PIN
Replace.

NUT
60 N·m
(44 lb-ft)

28. Reattach the lower arm to the ball joint with new nuts (both sides).

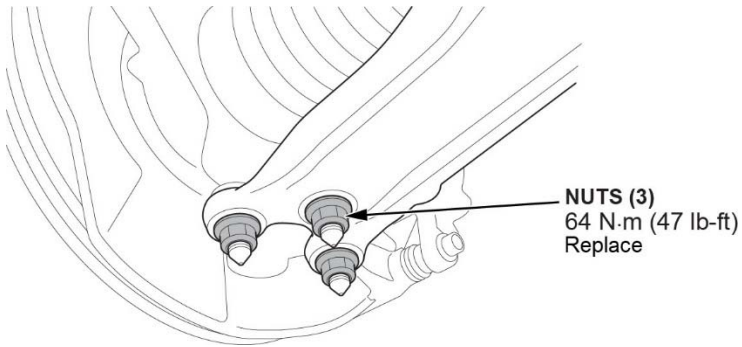

29. Reattach the front sway bar link to the sway bar with a new nut (both sides).

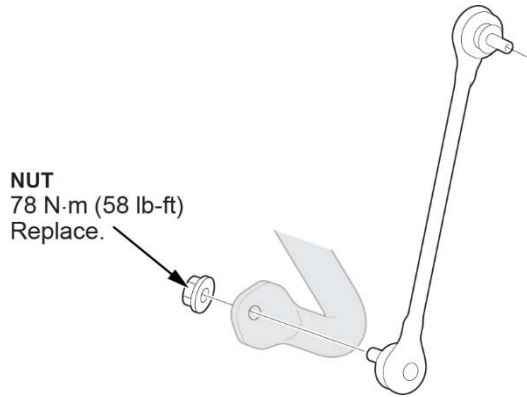

30. Install the exhaust A-pipe with new gaskets and mounting nuts.

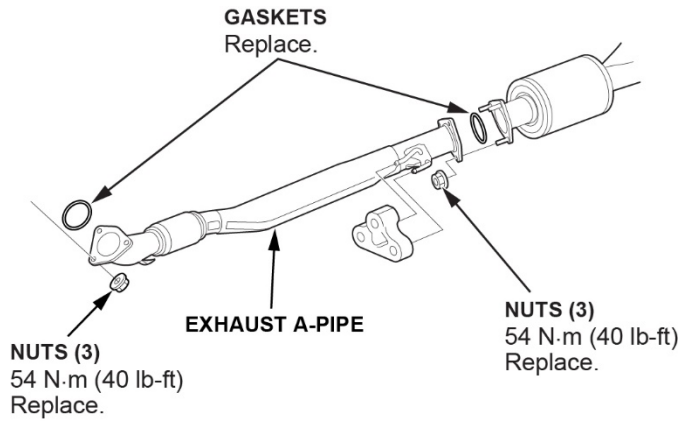

31. Install front engine undercover.

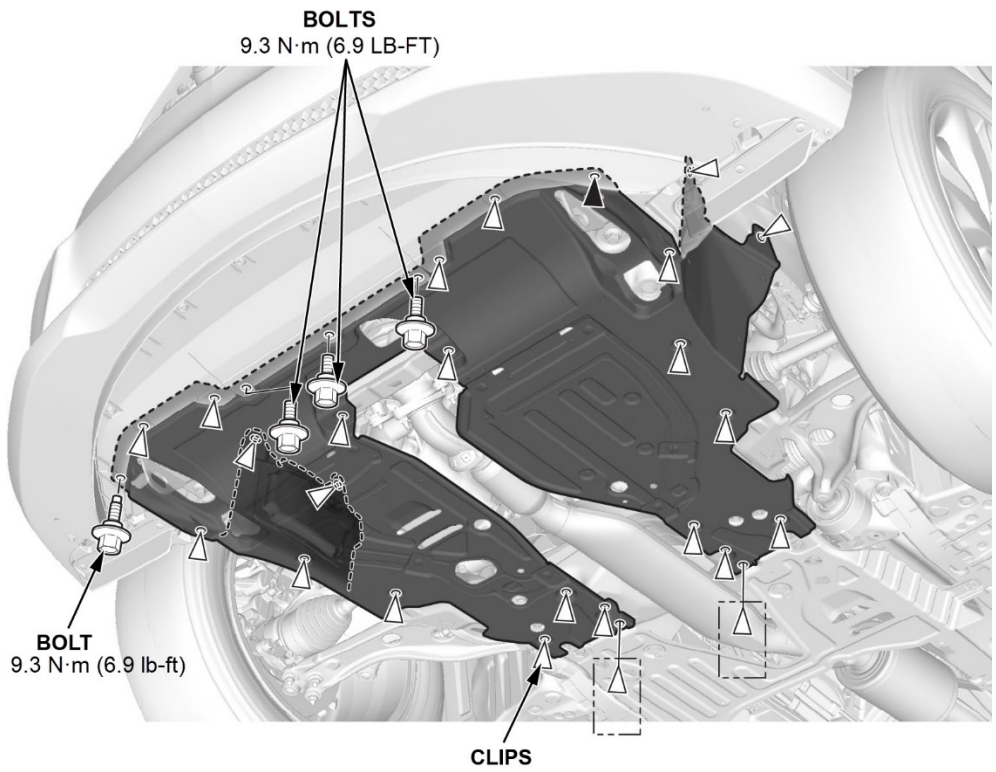

32. Install rear engine undercover.

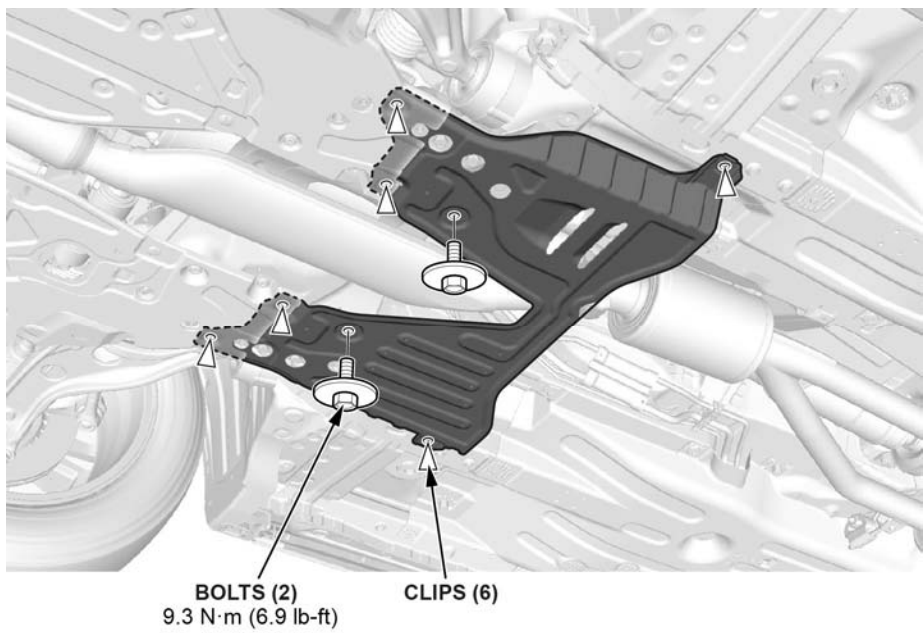

33. Install the front wheels.

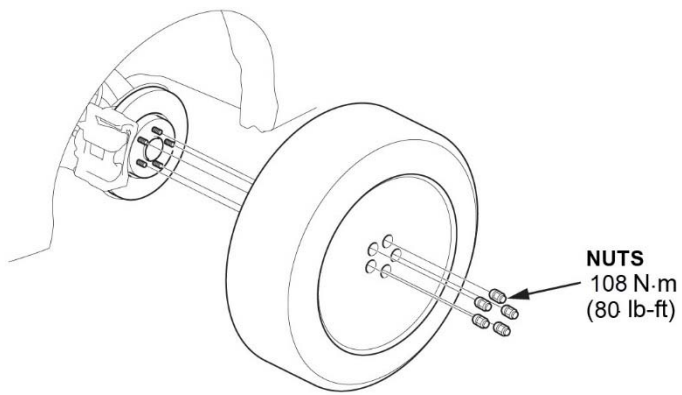

34. Install the steering joint by aligning the bolt hole on the steering joint with the groove around the pinion shaft.

- If the center guide is in place, install the steering joint by aligning the center guide.
- If the center guide is no longer in place, position the steering column by aligning the gap within the angle as shown.

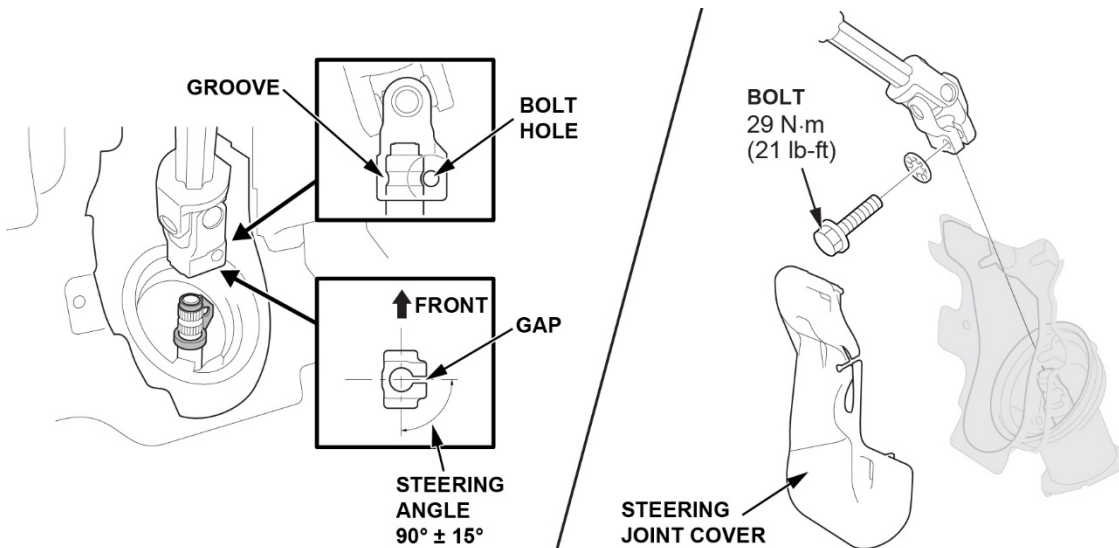

35. Connect the 12-volt battery negative cable.

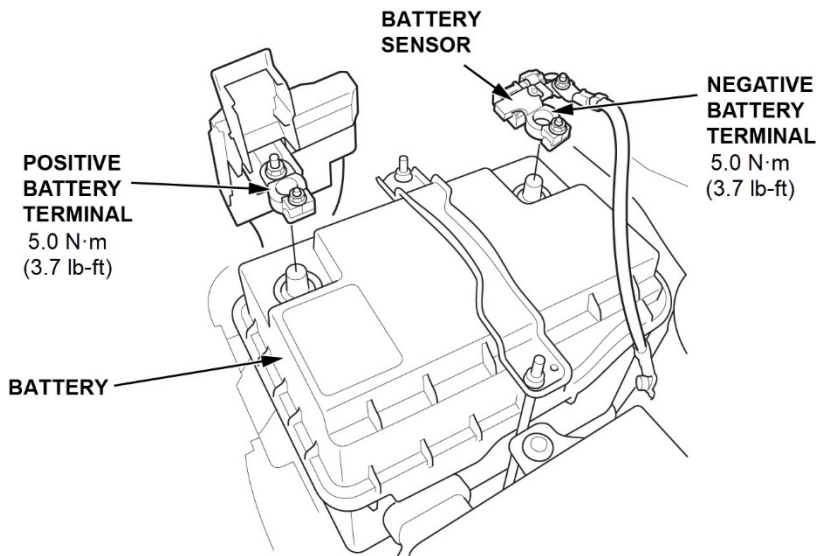

36. Do the EPS Control Unit update:

1. Connect the i-HDS to the DLC.

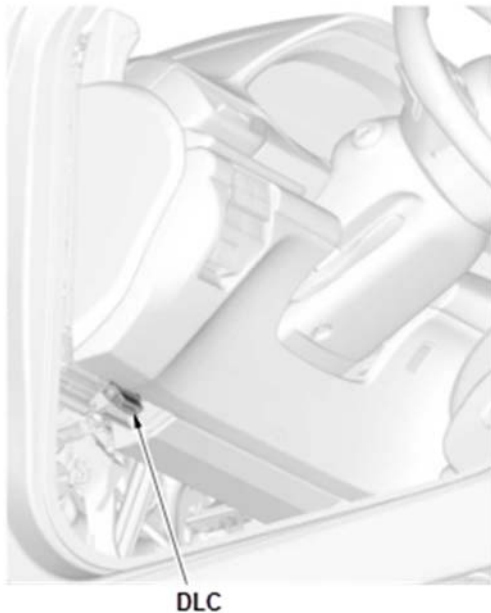

2. Follow the prompts to update the EPS control unit.

37. Do the steering gearbox after installation checks:

- With the front wheels straight ahead, make sure the steering wheel is centered and the turning revolutions from center to full lock (left and right) is equal. If not, check the installation of the steering wheel and the engagement of the joint/pinion shaft splines.
- With the tires raised off the ground, check for noise and abnormality by turning the steering wheel fully to the right and left several times.

38. Check that the EPS indicator does not come on.

39. Do a power steering assist check:

1. Start the engine and let it idle.
2. Attach a commercially available spring scale to the steering wheel.
3. With the engine idling and the vehicle on a clean, dry floor, pull the scale as shown and read it as soon as the tires begin to turn.
4. The amount of force measured should not exceed **29 N (6.5 lbf)**.



40. Do a wheel alignment.

41. Do the VSA Sensor Neutral Position Memorization procedure:

NOTE: Do not press the brake pedal during this procedure.

1. Park the vehicle on a flat and level surface.
2. Connect the i-HDS to the DLC located under the driver's side of the dashboard.
3. Turn the vehicle to the ON mode, but do not start the engine.
4. Set the steering wheel in the straight-ahead position.
5. Select **ADJUSTMENT > ABS/VSA > ALL SENSOR**, and follow the screen prompts.