

**March 27, 2024**

Version 4

**Safety Recall: 2023–24 Odyssey EPS Gearbox Assembly**Supersedes 24-004 dated February 28, 2024, to revise the information highlighted in **yellow**.**AFFECTED VEHICLES**

Year	Model	Trim Level	VIN Range
2023–24	Odyssey	ALL	Check the iN VIN status for eligibility.

**REVISION SUMMARY****Under PARTS INFORMATION, a heading was revised and a note was added.****BACKGROUND**

Due to a manufacturing error, a small number of vehicles may have been produced with improperly fastened bolts in the electronic power steering (EPS) gearbox assemblies. An improperly fastened bolt may allow moisture to enter the assembly and over time cause the steering gearbox to lock up. Improperly manufactured EPS gearbox assemblies may affect steering function, potentially increasing the risk of a crash or injury.

**CUSTOMER NOTIFICATION**

Owners of affected vehicles will be sent a notification of this campaign.

Do an iN VIN status inquiry to make sure the vehicle is shown as eligible.

Some vehicles affected by this campaign may be in your new or used vehicle inventory.

Failure to repair a vehicle subject to a recall or campaign may subject your dealership to claims or lawsuits from the client or anyone else harmed as a result of such failure. To see if a vehicle in inventory is affected by this safety recall, do a VIN status inquiry before selling it.

**CORRECTIVE ACTION**

If the VIN is eligible, replace the EPS gearbox.

**CUSTOMER INFORMATION:** The information in this bulletin is intended for use only by skilled technicians who have the proper tools, equipment, and training to correctly and safely maintain your vehicle. These procedures should not be attempted by “do-it-yourselfers,” and you should not assume this bulletin applies to your vehicle, or that your vehicle has the condition described. To determine whether this information applies, contact an authorized Honda automobile dealer.

## PARTS INFORMATION

To obtain the correct parts for each vehicle repair, **contact your local parts analyst** with the vehicle's VIN, the Power Steering Rack Assembly part number, and this service bulletin number. The parts center will order the correct parts on behalf of your dealer after the eligibility of the VIN is confirmed.

### Steering Rack Part Numbers (needed when calling parts center)

Part Name	Part Number	Quantity
Power Steering Rack Assembly (EXL)	53622-THR-A35	1
Power Steering Rack Assembly (ELITE, TRG, SPORT)	53622-THR-A45	1
Power Steering Rack Assembly (EX, LX)	53622-THR-A62	1

### Parts included:

**NOTE:** The *Must Replace* parts listed below will shipped separately.

Part Name	Quantity
Flange Bolt (12X30)	8
Flange Bolt (10x103)	1
Flange Bolt (12X45)	1
Flange Bolt (14X84)	1
Exhaust Pipe Gasket	2
Prechamber Gasket	1
Flange Bolt (14X58)	2
Flange Bolt (10X30)	2
Flange Bolt (10X20)	1
Bolt, Flange (10X35)	2
Flange Bolt (14X125)	2
Flange Bolt (14X140)	2
Flange Bolt (10X25)	4
Flange Bolt (10X60)	2
Flange Bolt (10X16)	7
Self-Lock Nut (10MM)	9
Flange Nut (12MM)	2
Castle Nut (14MM)	2
Flange Nut (12MM)	4
Split Pin (3.0X22)	2
Flange Bolt (10X16)	2

## TOOL INFORMATION

Tool Name	Tool Number	Quantity
Subframe Adapter	VSB02C000016	1
Ball Joint Remover 28mm	07MAC-SL00202	1
Ball Joint Thread Protector	07AAF-SDAA100	1
Ball Joint Remover 32mm	07MAC-SL00102	1
Ball Joint Thread Protector	071AF-SZNA100	1
Engine Balance Bar	VSC02C000041	1
Engine Support Hanger	AAR-T1256	1

## WARRANTY CLAIM INFORMATION

Please enter the EPS Gearbox replacement part number under template A.

Operation Number	Description	Flat Rate Time	Defect Code	Symptom Code	Template ID	Failed Part Number
5131L8	Replace EPS Gearbox (includes alignment)	3.1	6GZ00	LHU00	A24004A	53622-THR-A35

Skill Level: Repair Technician

## REPAIR PROCEDURE

1. Remove the front bulkhead cover.

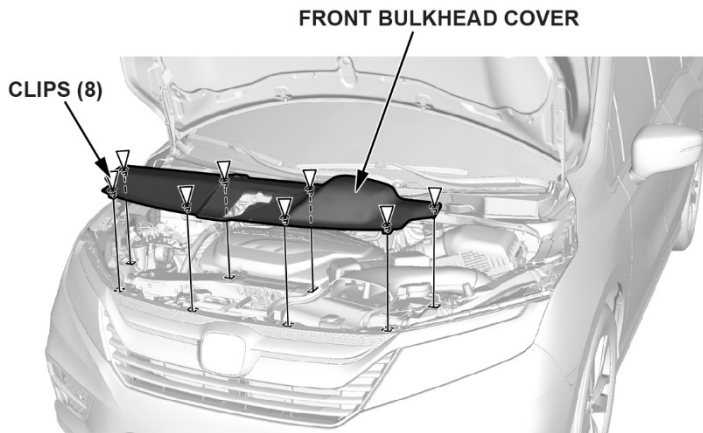

2. Remove the air intake duct and air guide.

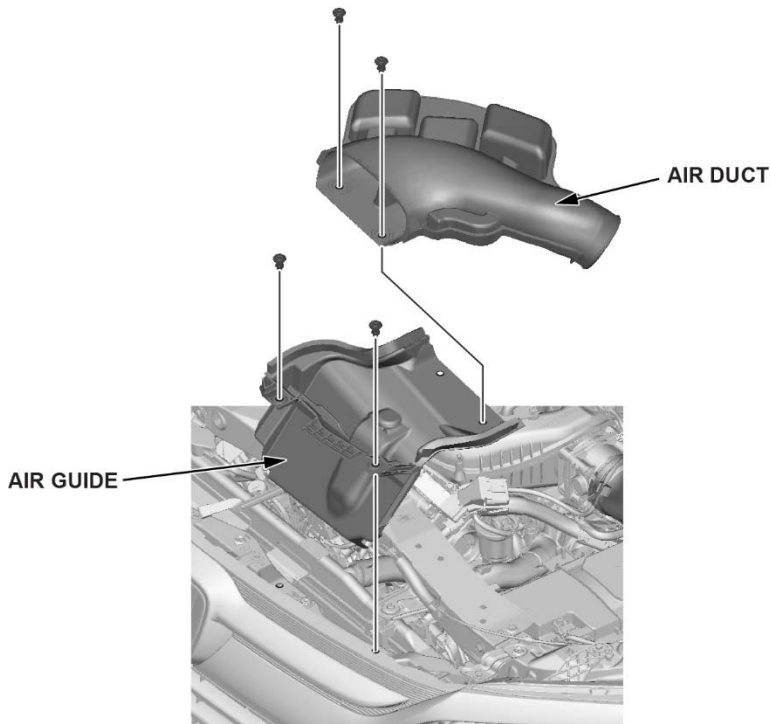

3. Disconnect the 12-volt battery negative cable.

NOTE:

- With the driver's door open, turn the vehicle to the OFF (LOCK) mode, wait at least 3 minutes before disconnecting the 12-volt negative battery cable.
- To protect the 12-volt battery sensor connector from damage, do not hold it when removing the terminal.
- Do not disconnect the 12-volt battery sensor from the cable.

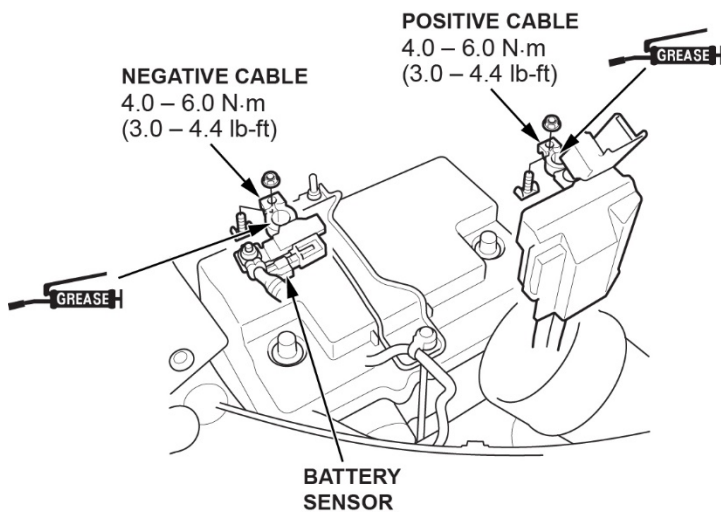

4. Remove the engine cover.

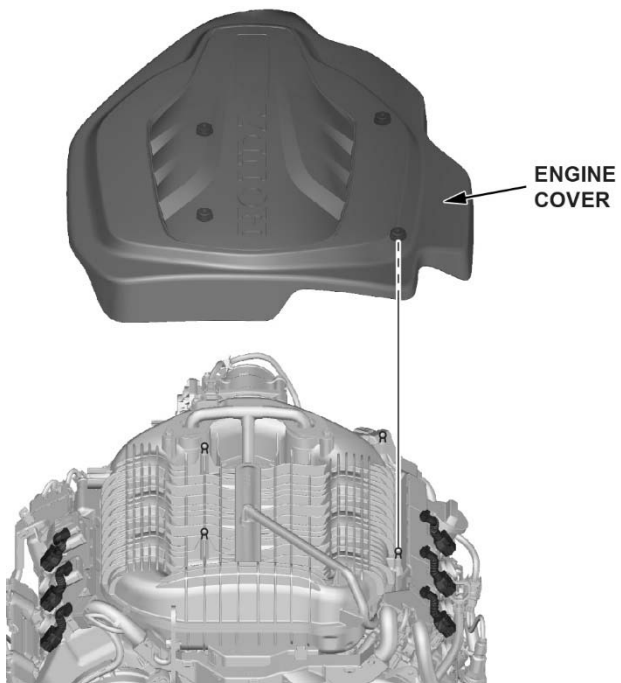

5. Remove the No. 6 cylinder ignition coil.

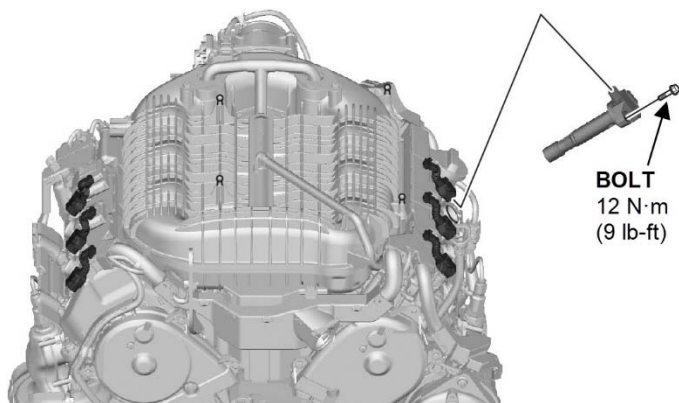

6. Remove the windshield wiper arms.

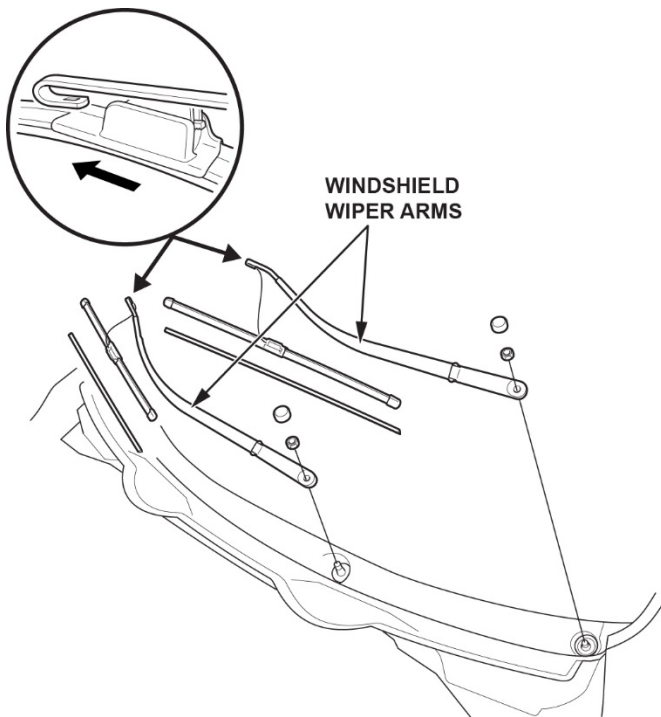

7. Remove the cowl cover.

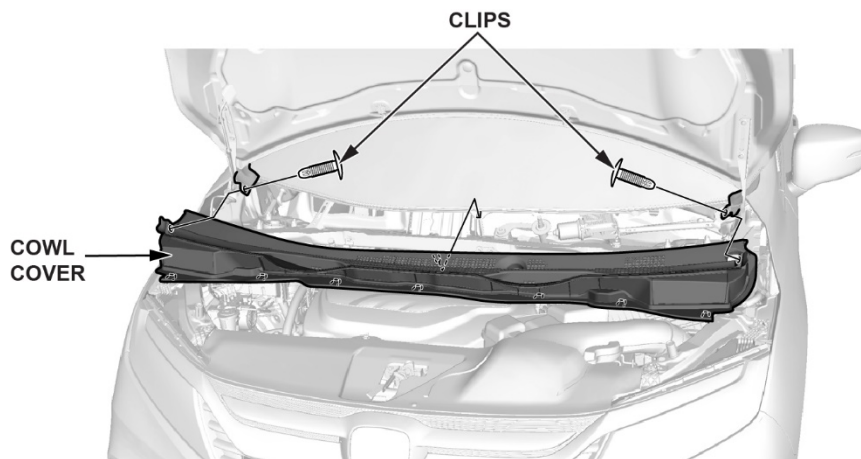

8. Remove the front engine mount stop and the engine mount mounting bolt.

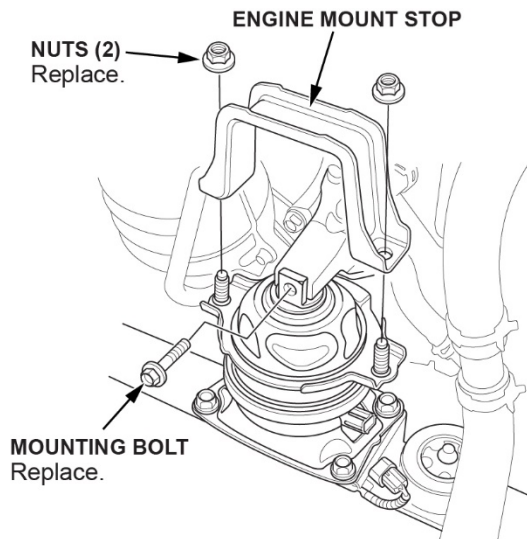

9. Remove the following in this order: rear engine mount stop, heat shield, and the rear engine mount mounting bolt, then disconnect the connector.

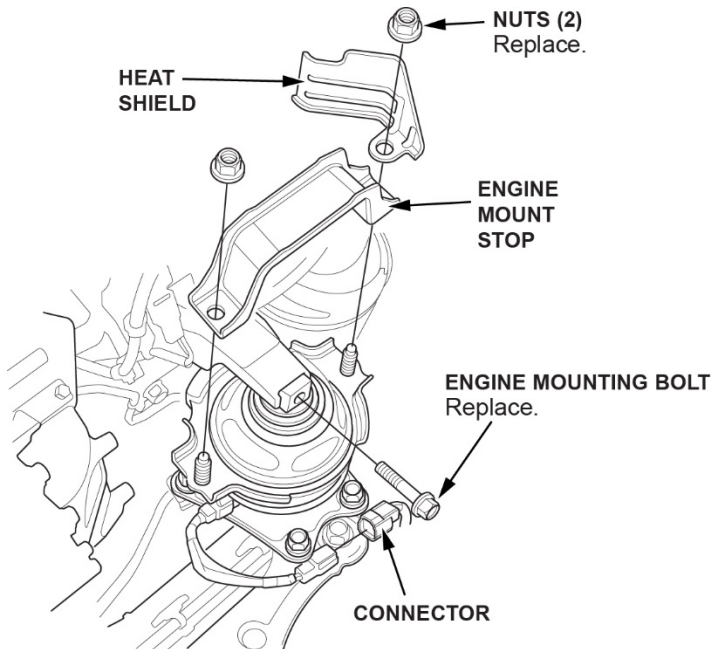

## 10. Install the Engine Support Hanger

### NOTE:

- Be careful when working around the windshield.
  - AAR-T1256 two sets required for stacking additional cross section bars.
  - Be careful not to damage the hood opener cable when installing the engine support hanger at the front bulkhead.
1. Remove the front damper caps.
  2. Install the engine hanger balance bar. Attach the front arm to the front cylinder head with a commercially available spacer and a **10 x 1.25 mm bolt**. Attach the rear arm to the rear cylinder head with a commercially available spacer and an **8 x 1.25 mm bolt**.
  3. Install the engine support hanger onto the vehicle as shown and attach the hook to the slotted hold in the engine hanger balance bar. Tighten the wing nut by hand, and lift and support the engine/transmission.

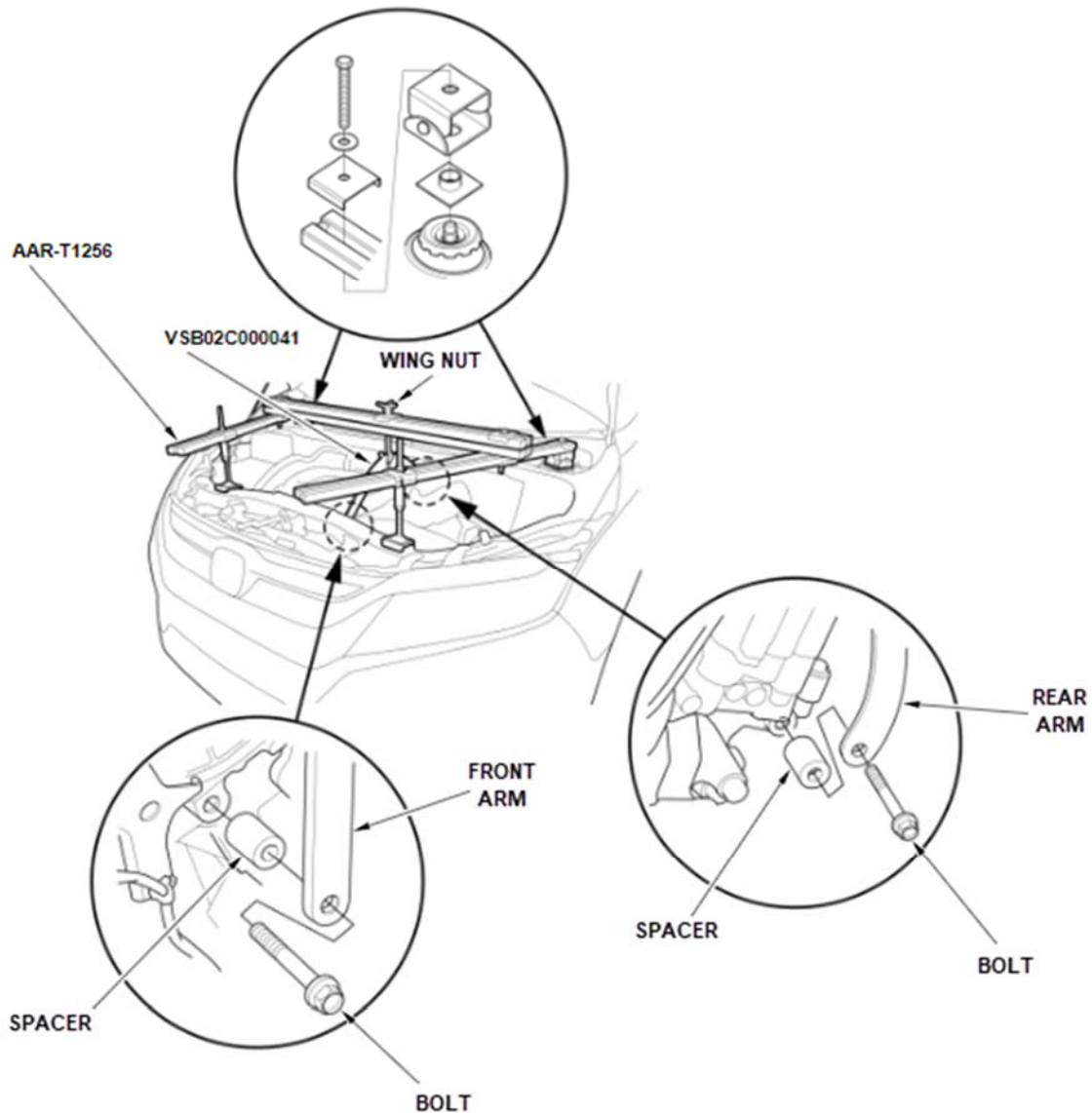



11. Disconnect the steering joint:

1. Remove the driver's side center console side panel.

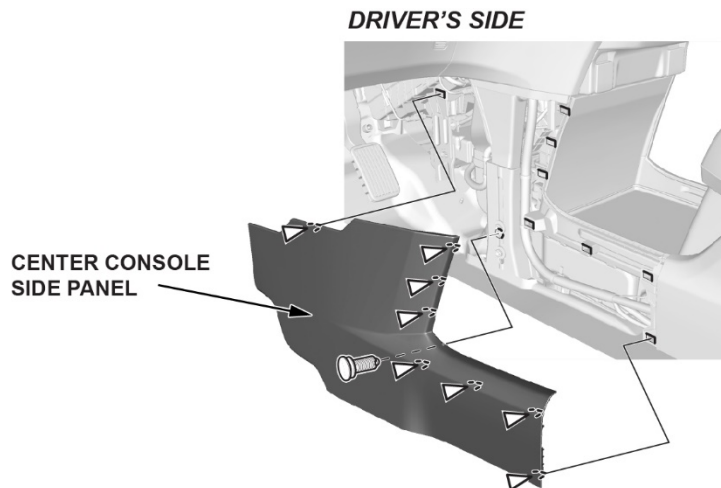

2. Remove the steering joint cover.
3. Disconnect the steering joint.

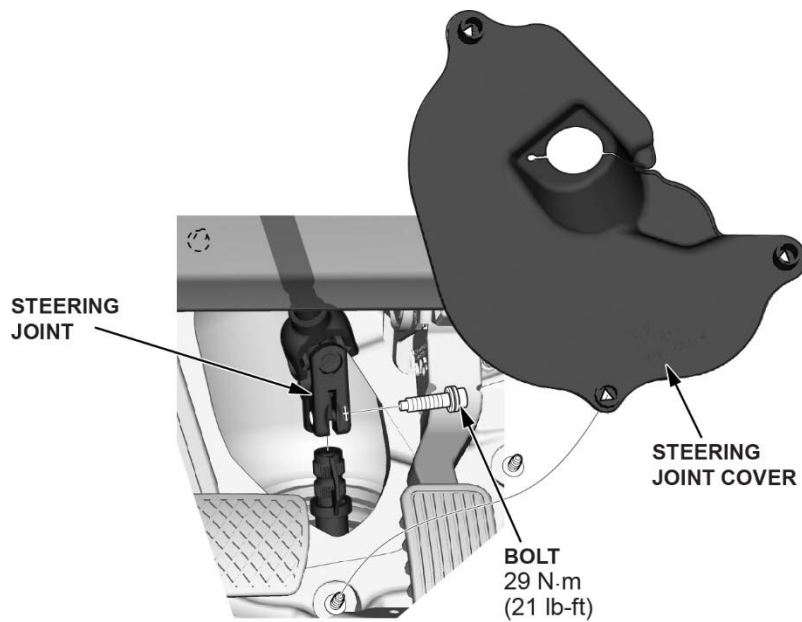

12. Lift the vehicle.

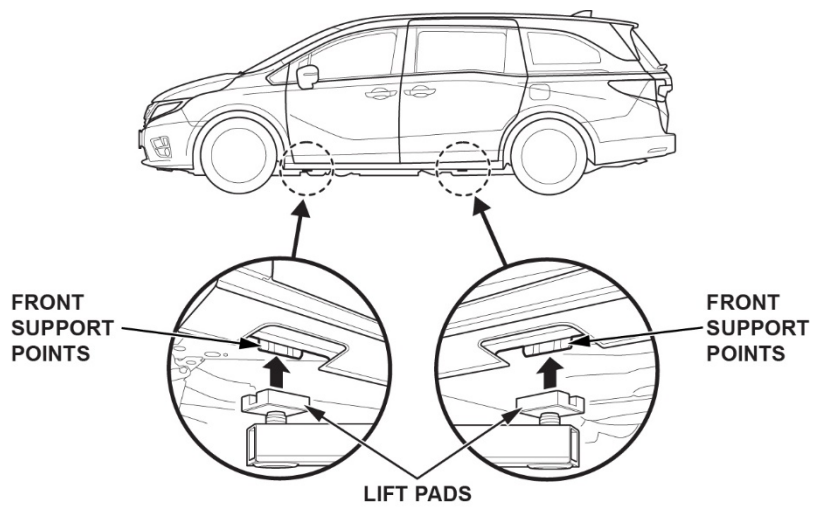

13. Remove both front wheels.

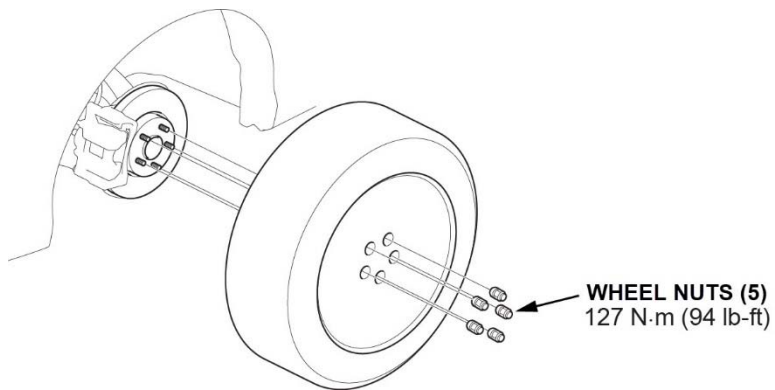

14. Disconnect the stabilizer bar link upper mounting point (both sides).

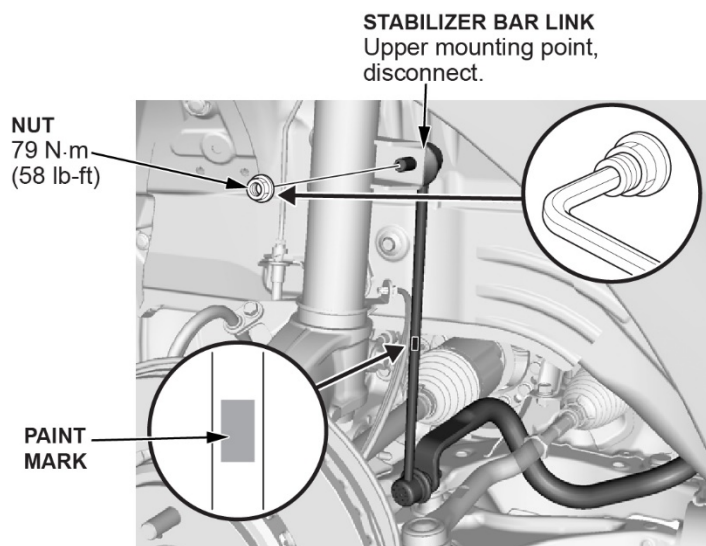

15. Remove the splash shield.

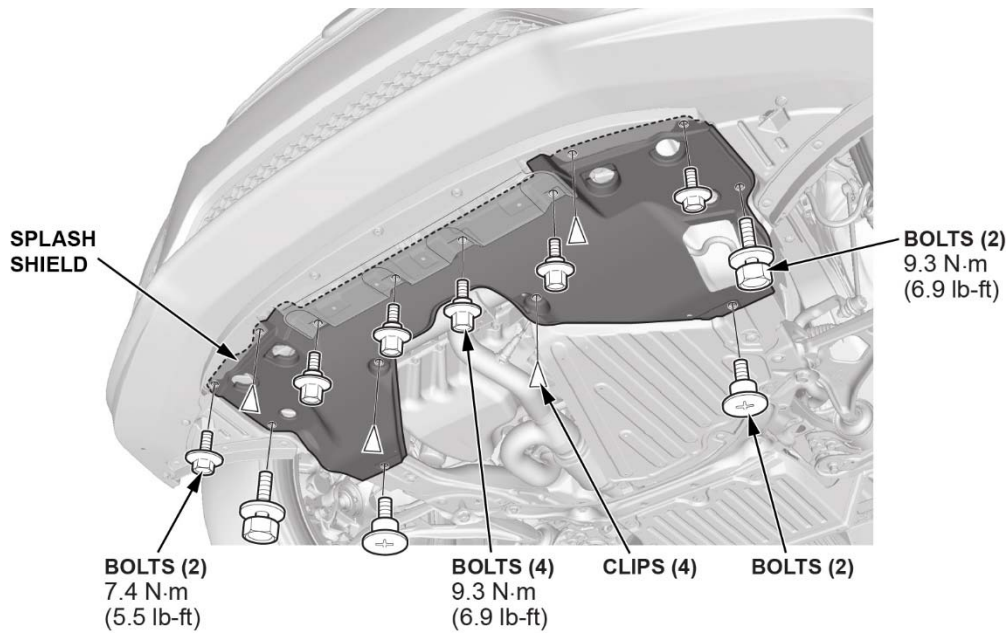

16. Remove the engine undercover.

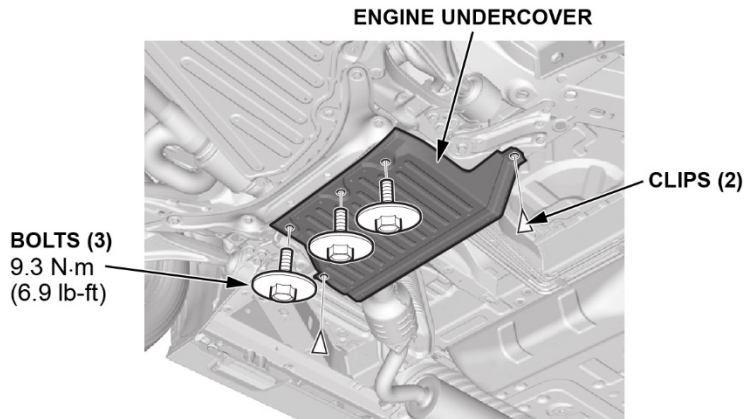

17. Remove the transmission undercover.

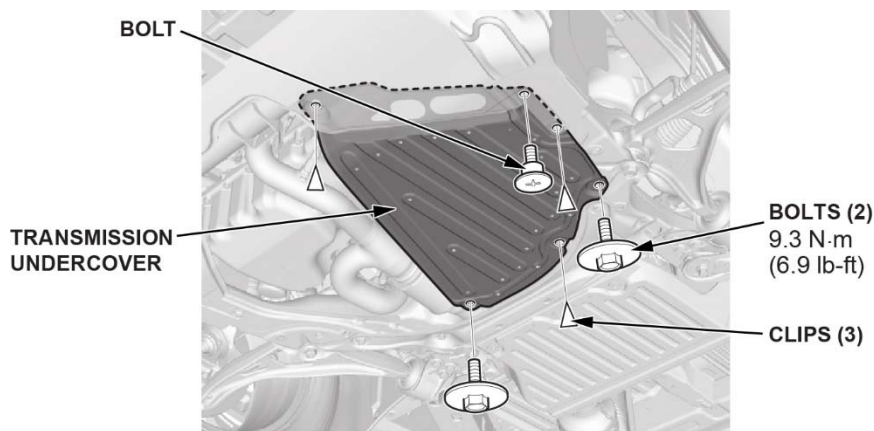

18. Remove the transmission mount to subframe bolt.

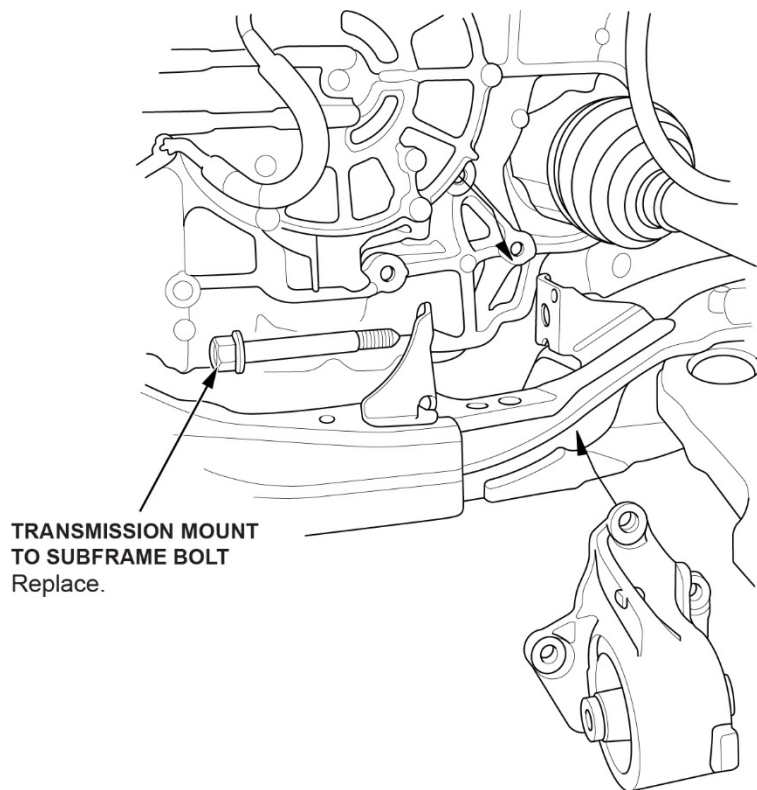

19. Disconnect the EPS motor/control unit and the rear engine mount harness connector.

1. Disconnect the connector by pushing the lock then lifting the lever up.
2. Disconnect the connector.

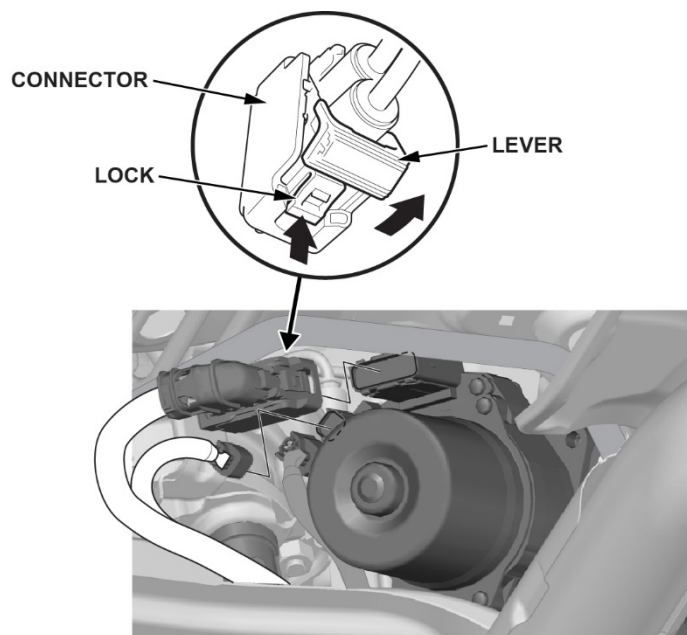

20. Disconnect the tie rod end from the knuckle (both sides):

NOTE: Be careful not to damage the ball joint boot when installing the ball joint remover.

1. Remove the cotter pin.
2. Remove the tie rod ball joint nut.
3. Disconnect the tie-rod end ball joint from the knuckle using the ball joint thread protector and the ball joint remover.

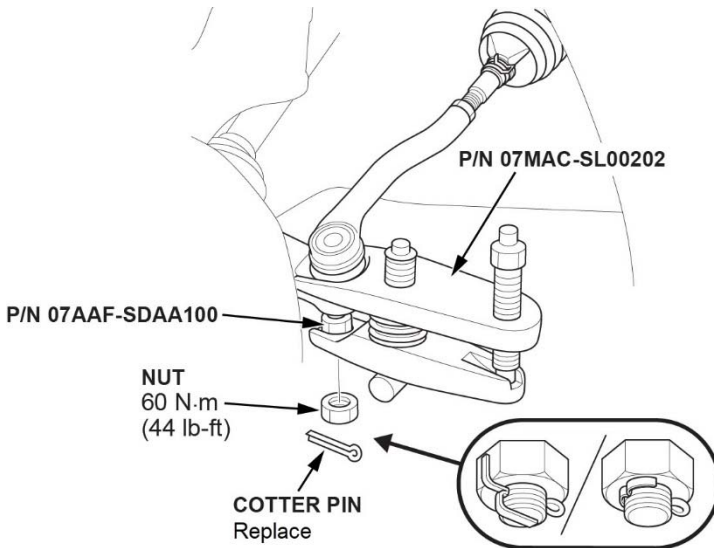

21. Disconnect the lower arm ball joint from the knuckle (both sides):

NOTE: Be careful not to damage the ball joint boot when installing the ball joint remover.

1. Remove the lock pin from the lower arm ball joint.
2. Remove the castle nut.
3. Disconnect the lower ball joint from the knuckle using the ball joint thread protector and the ball joint remover.

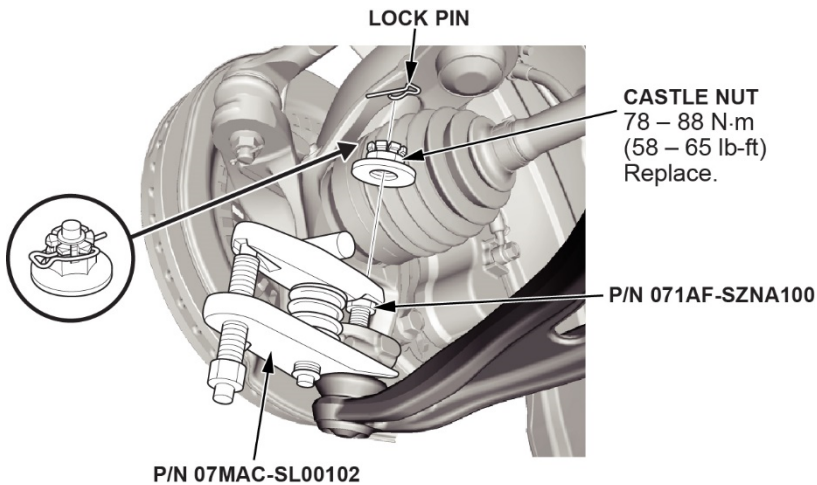

22. Remove the front subframe stiffener plate.

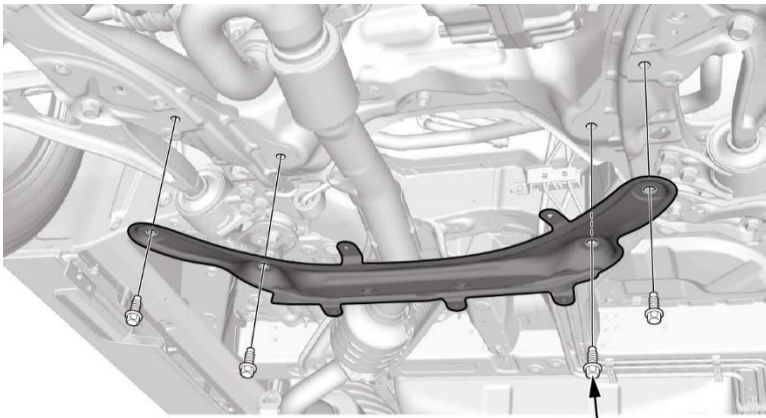

**BOLTS (4)**  
54 N·m (40 lb-ft)  
Replace.

23. Disconnect O2 Sensor

24. Remove under-floor TWC (A-pipe).

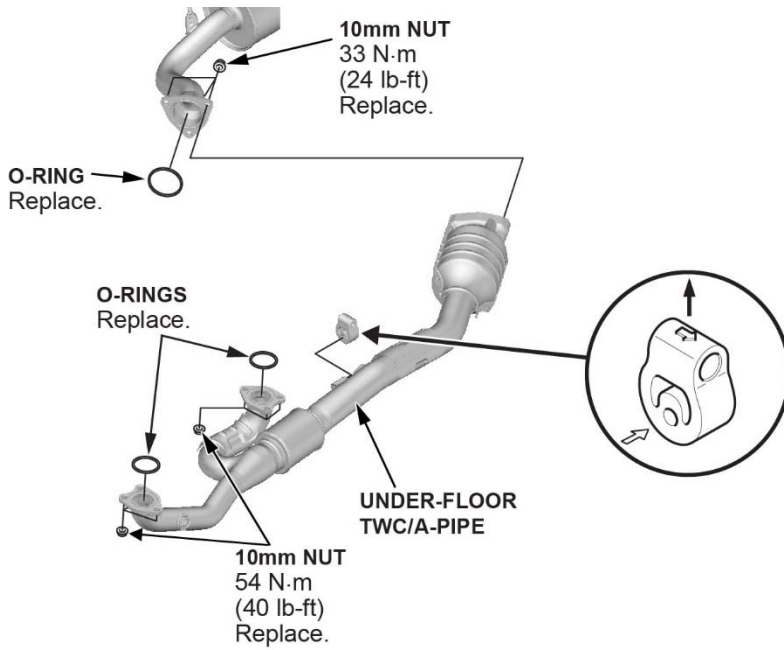

25. Disconnect the ACM subharness connector and remove the harness clip.

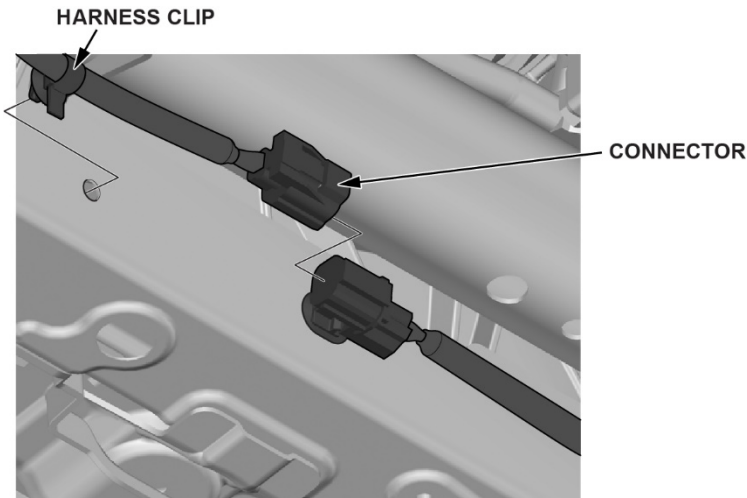

26. Attach the subframe adapter and transmission jack.

1. Loop the belt over the front subframe and secure the belt with its stop, then tighten the wing nut.
2. Raise a transmission jack and line up the slots in the subframe adapter arms with the bolt holes on the transmission jack base, then securely attach them with four bolts.

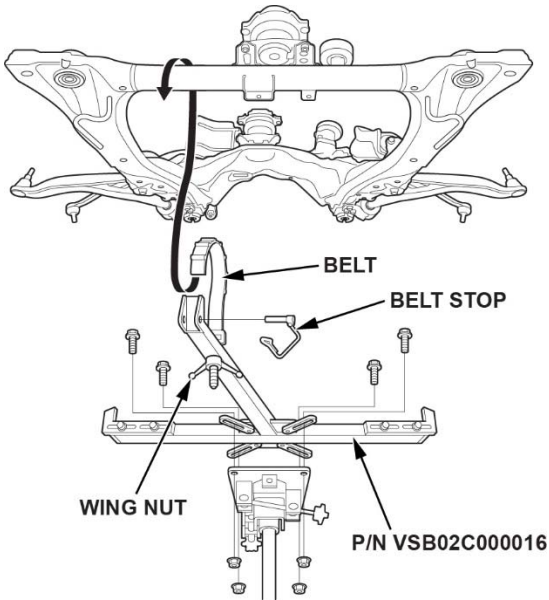

27. Remove the front subframe:

1. Remove the rear stiffener bolts.
2. Remove the front stiffener bolts.
3. Remove the subframe bolts and stiffeners.
4. Lower the subframe.

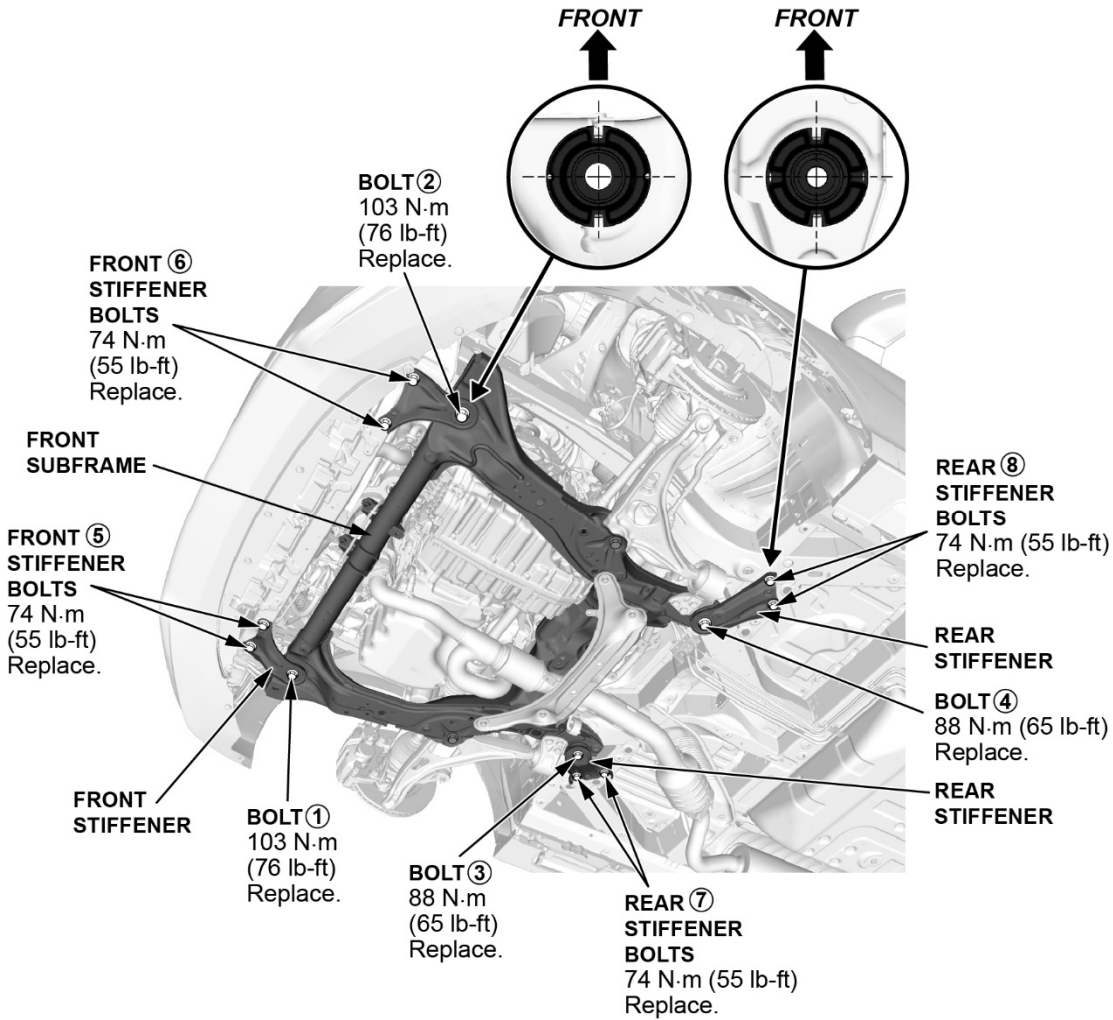



28. Remove rear engine mount from EPS gearbox.

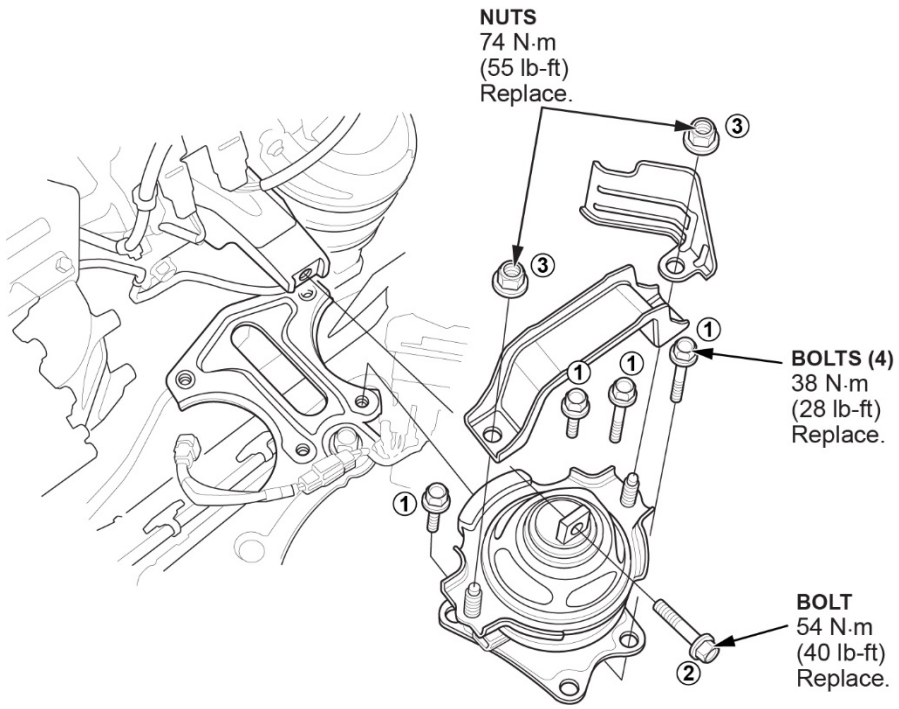

29. Remove the tie rod ends from the steering gearbox (both sides).

NOTE: Count the number of turns used when removing the tie rod ends.

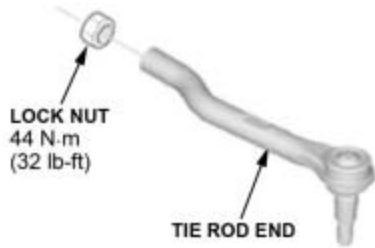

30. Remove the steering gearbox.

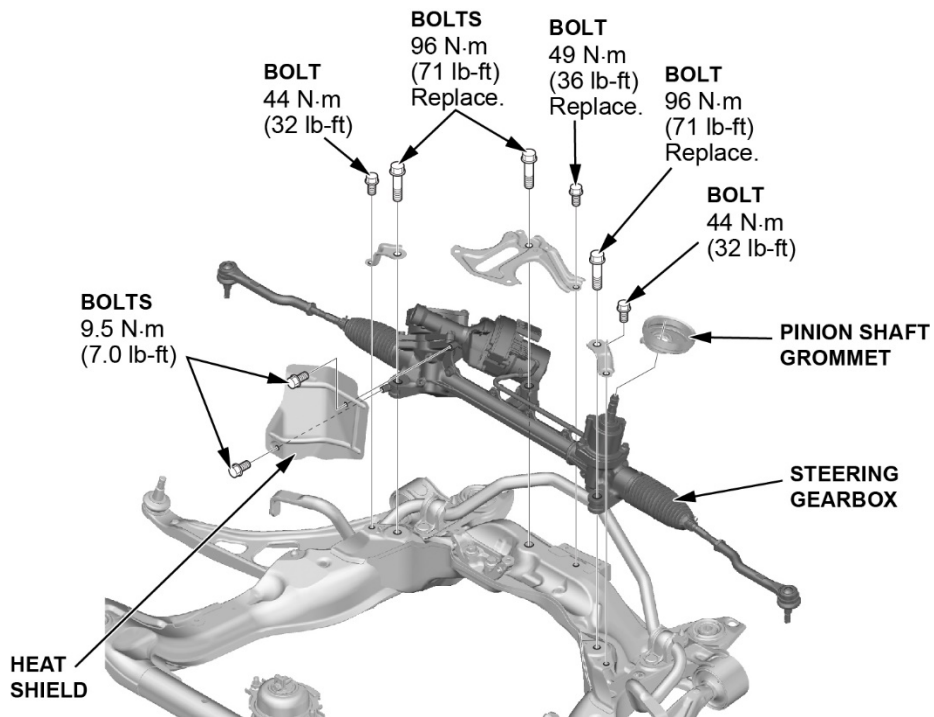

31. Remove the heat shield.

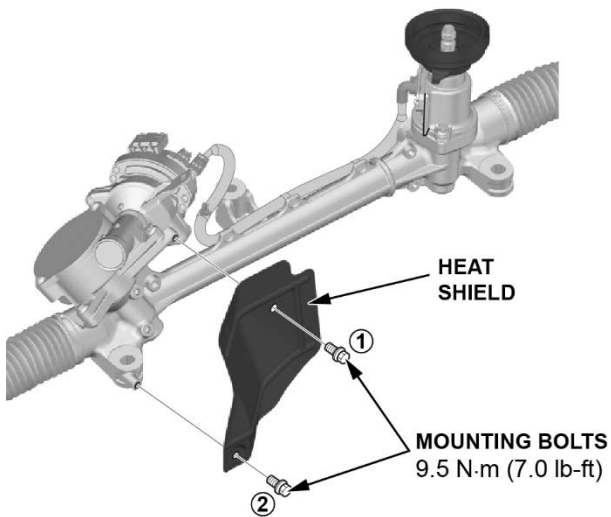

32. Remove the pinion shaft grommet and transfer it onto the new steering gearbox.

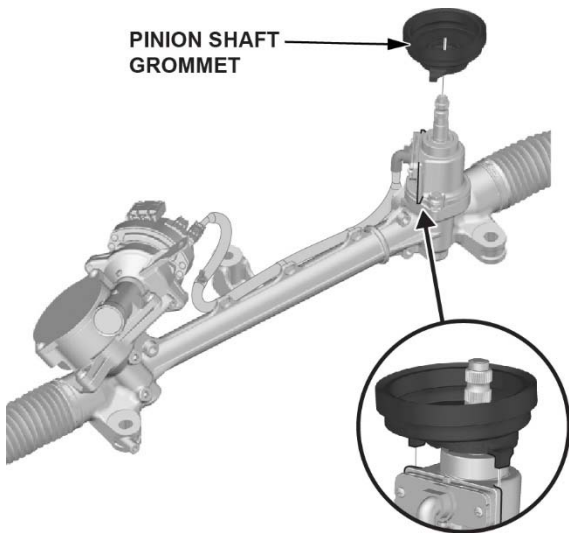

33. Install the heat shield:

1. Loosely install the heat shield.
2. Tighten the mounting bolts to **9.5 N·m (7.0 lb-ft)**.

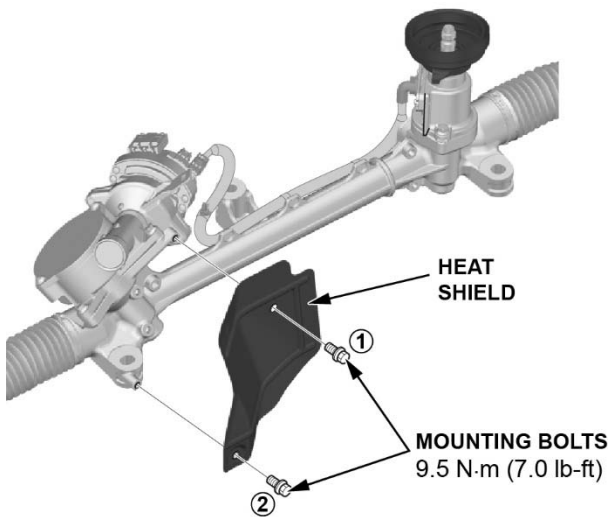

34. Install the new steering gearbox:

1. Loosely install the steering gearbox stiffeners.
2. Install the steering gearbox mounting bolts and the stiffener mounting bolts.
3. Tighten the steering gearbox and stiffener mounting bolts to the specified torque in sequence.

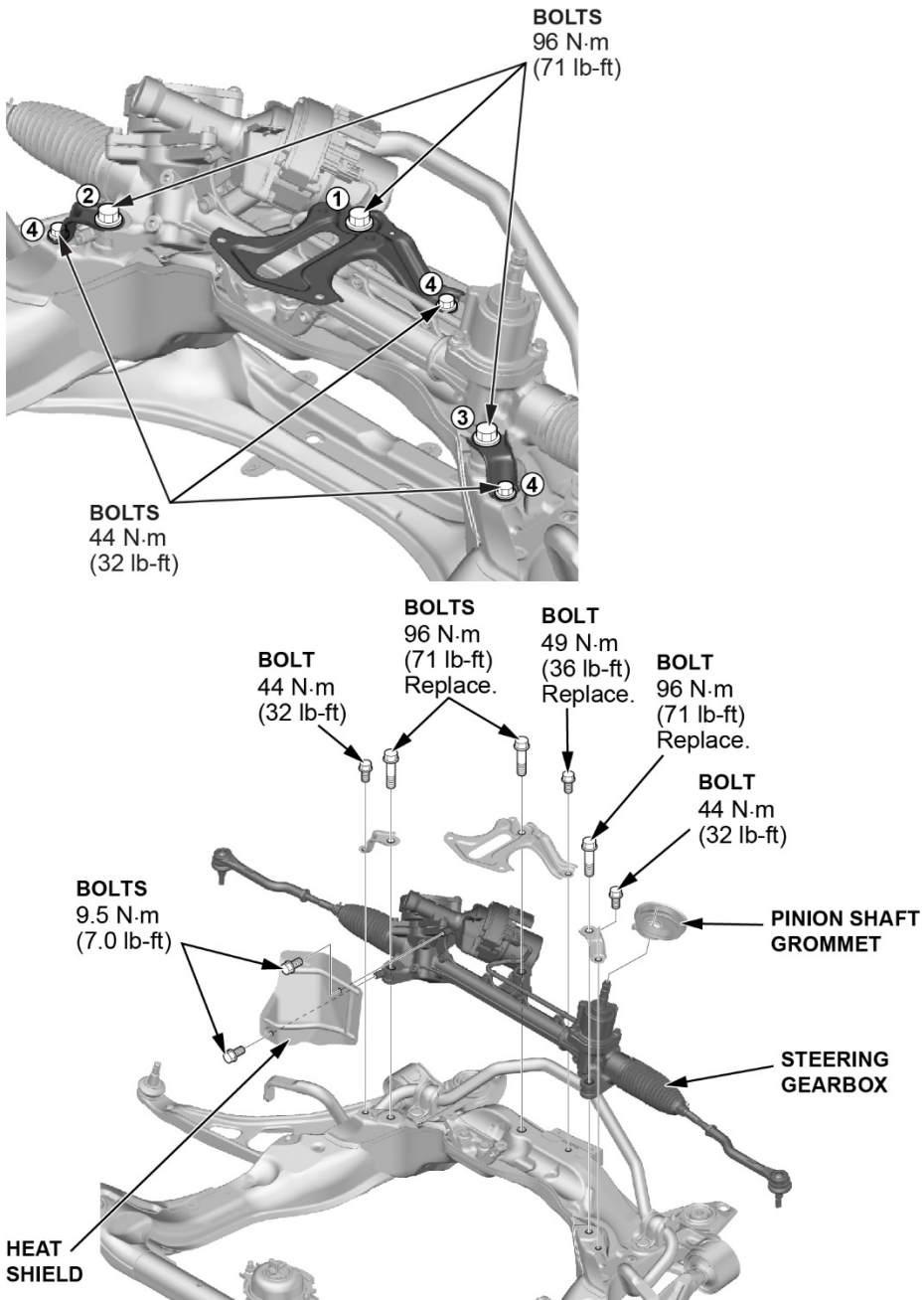

35. Install tie rod ends to steering gearbox, using the same number of turns you counted when removing (both sides).

NOTE: Final tightening of tie rod lock nut will be done at alignment.

36. Install the rear engine mount to the EPS gearbox mounting plate and torque the mounting bolts to **38 N·m (28 lb-ft)**.

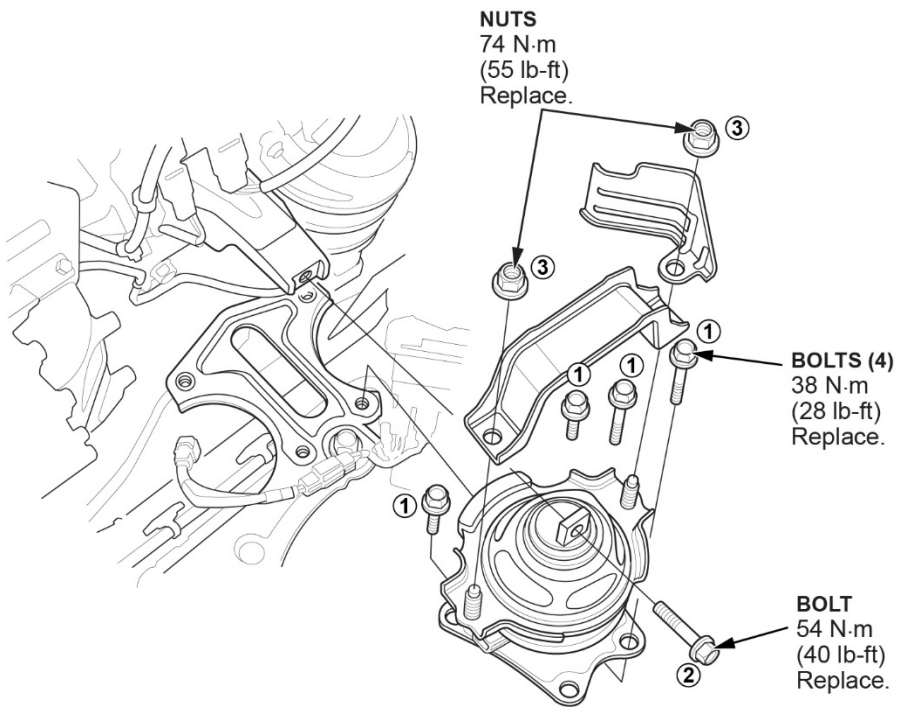

37. Install the front subframe:

NOTE: After loosening the subframe mounting bolts, replace them with new ones.

1. Lift the front subframe up to the body and loosely install the new subframe mounting bolts.
2. Loosely install the front stiffeners with new mounting bolts.
3. Loosely install the rear stiffeners with new mounting bolts.
4. Tighten the subframe mounting bolts to the specified torque **in the numbered sequence**.
5. Check all of the subframe mounting bolts and retighten, if necessary.

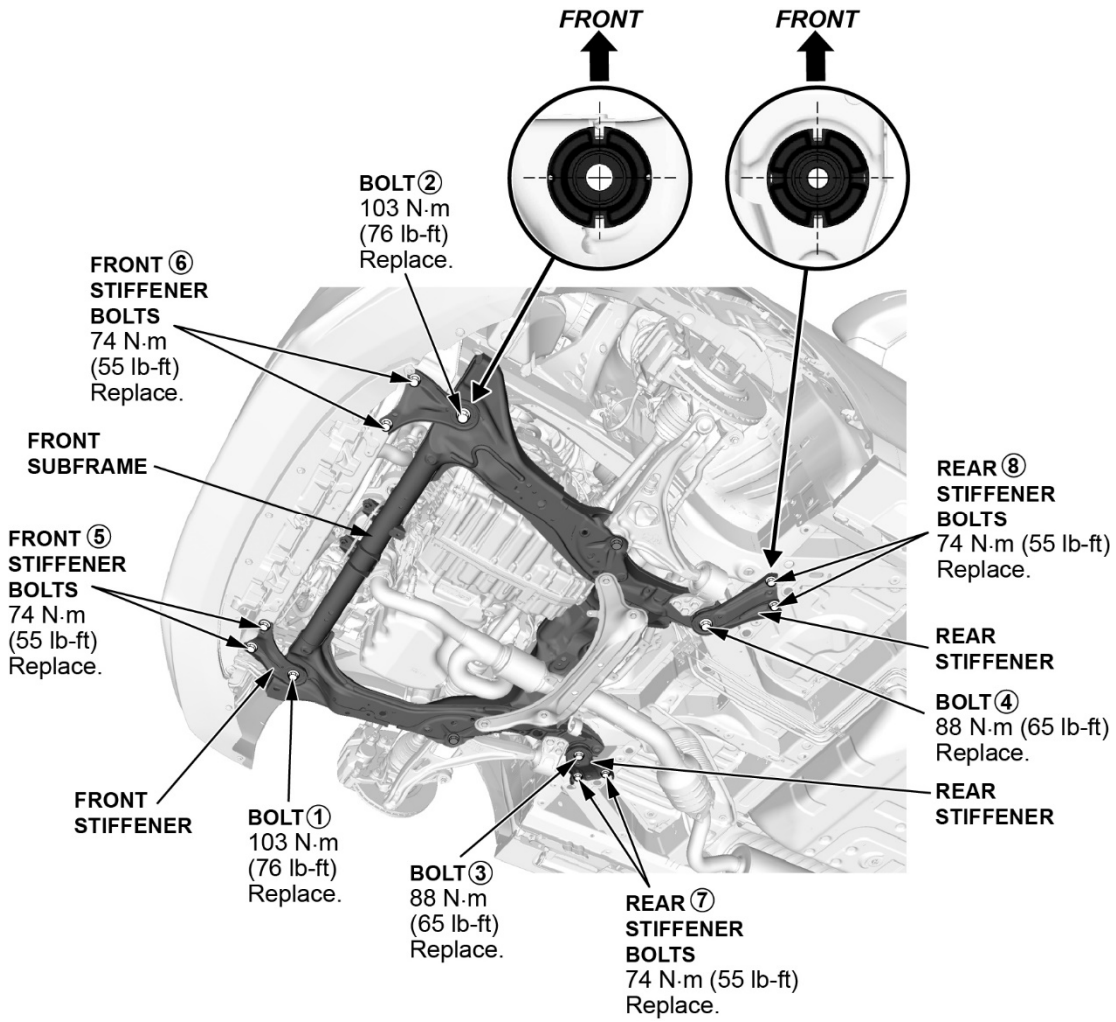

38. Remove the transmission jack/subframe adapter.

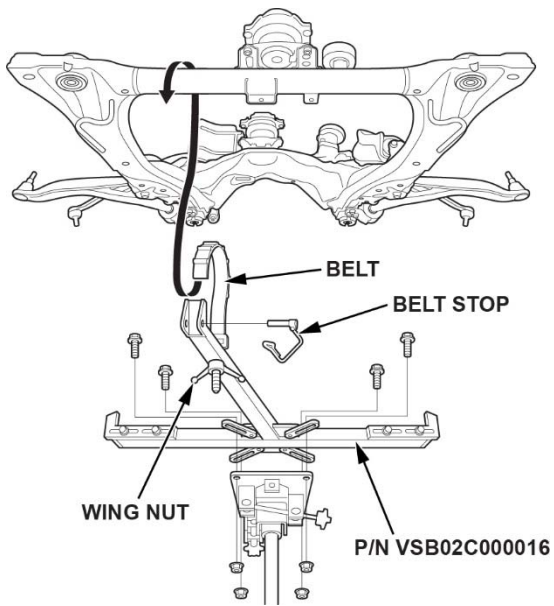

39. Connect the lower arm ball joint (both sides).

NOTE:

- Use a new castle nut.
- Torque the castle nut to the lower torque specification, then tighten it only far enough to align the slot with the ball joint pin hole. **Do not** align the castle nut by loosening it.
- Be careful not to damage the ball joint boot when connecting the knuckle.
- Before connecting the ball joint, degrease the threaded section and the tapered portion of the ball joint pin, along with the ball joint connecting hole. Also degrease the threaded section, and the mating surfaces of the castle nut.

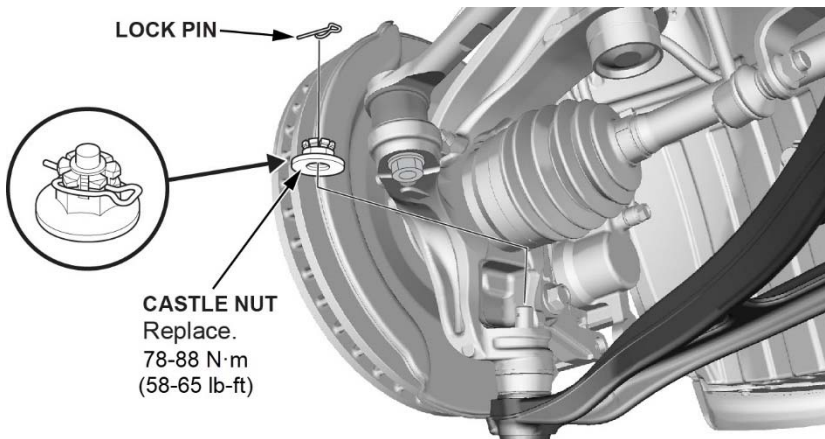

40. Connect the tie rod end ball joint (both sides).

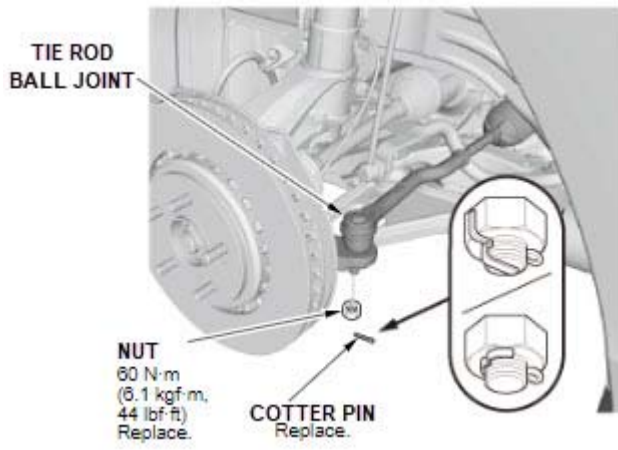

41. Connect the stabilizer bar link upper mounting point (both sides).

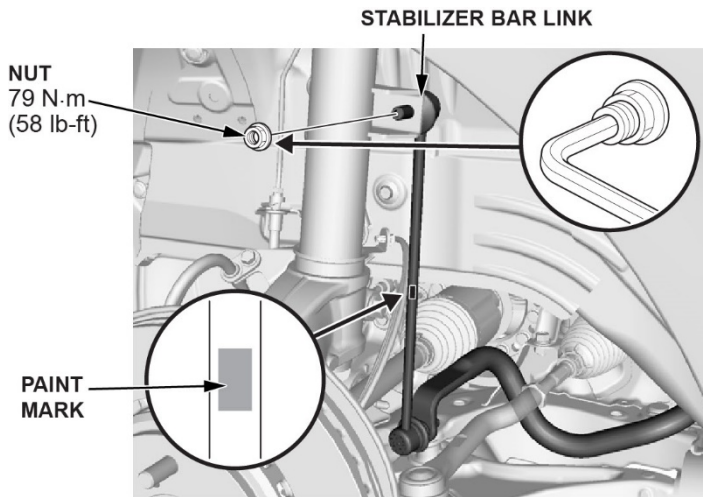



42. Connect the EPS/motor control unit.

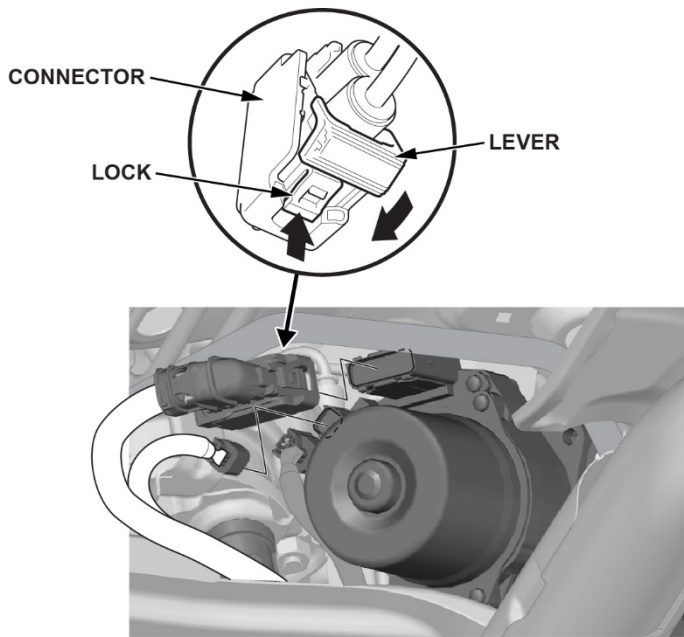

43. Install the under-floor TWC/exhaust A-pipe.

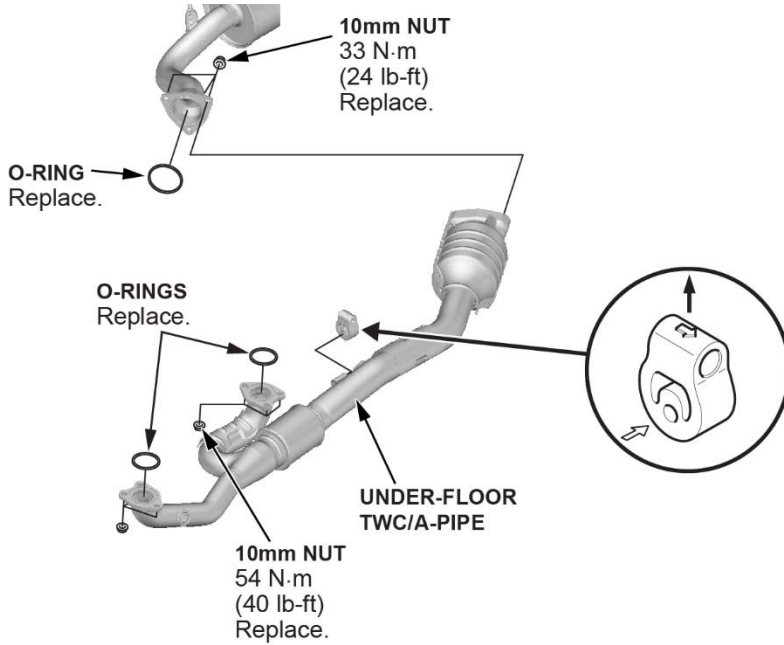

44. Reconnect the O<sub>2</sub> sensor.

45. Install the front subframe stiffener plate.

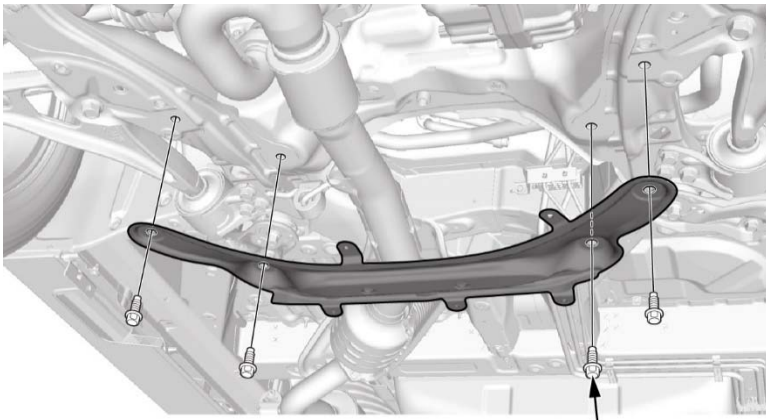

**BOLTS (4)**  
54 N·m (40 lb-ft)  
Replace.

46. Connect the front ACM subharness.

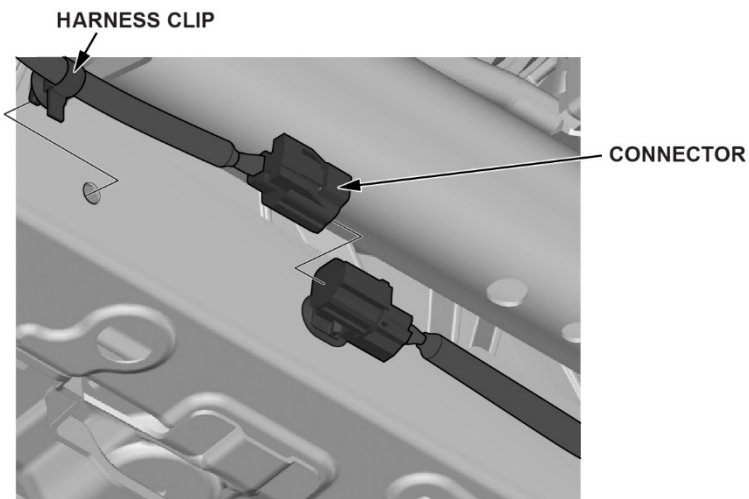

47. Loosely install the transmission mount.

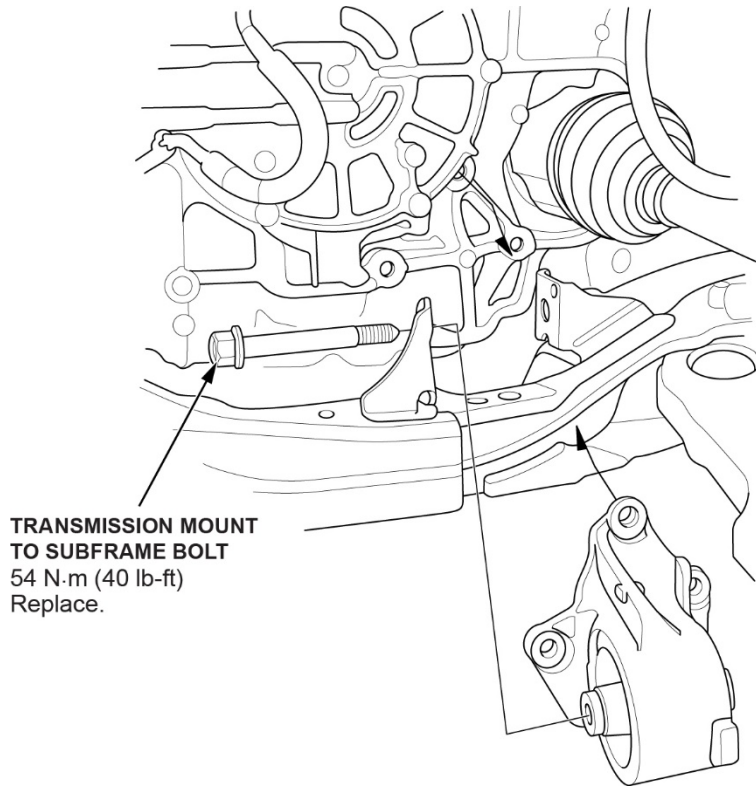

48. Lower the vehicle to working height.

49. Remove the engine support hanger, then remove the engine hanger balance bar.

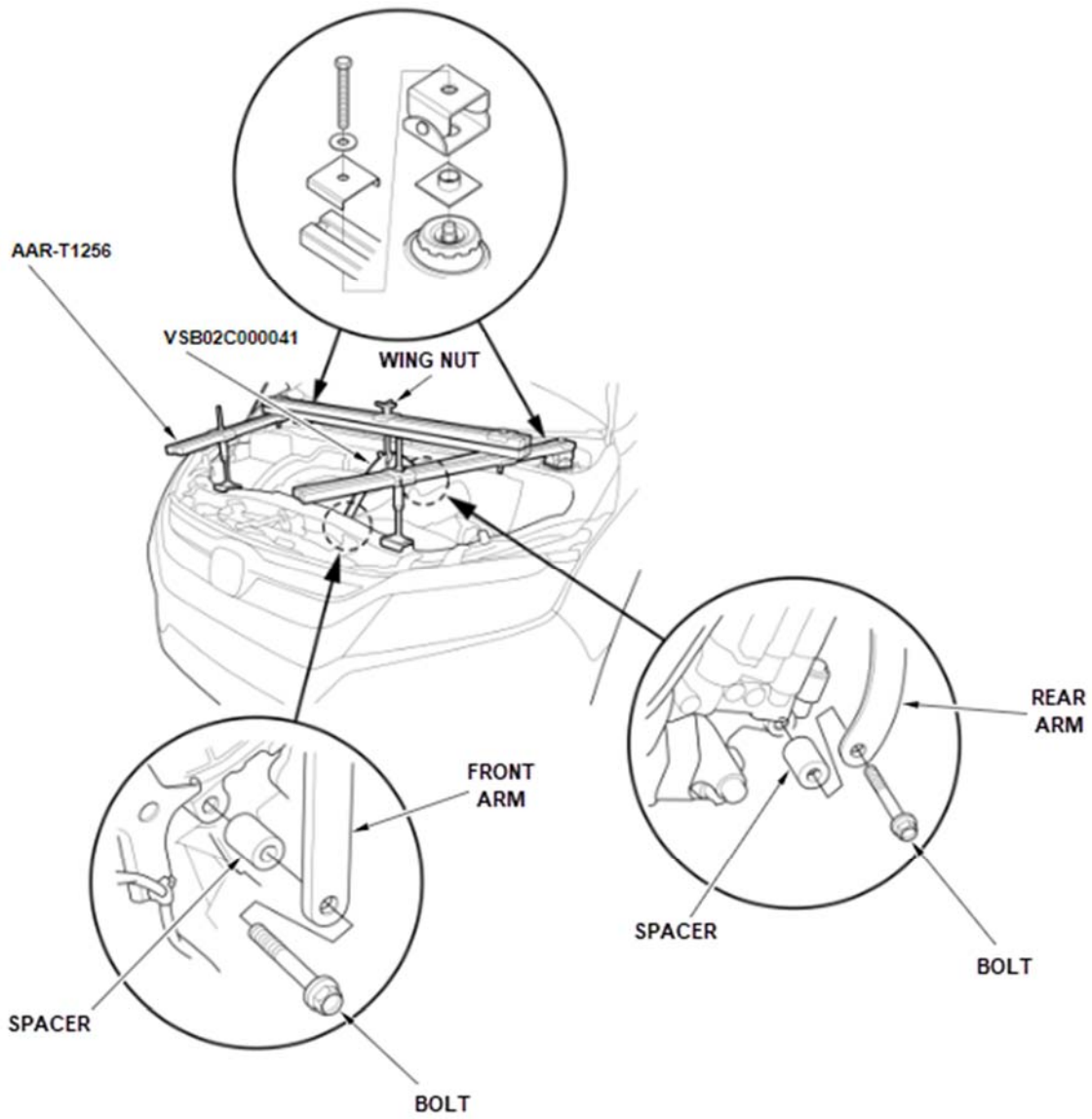

50. Loosely install the rear engine mount stop and the rear engine mount mounting bolt, then reconnect the rear mount connector.

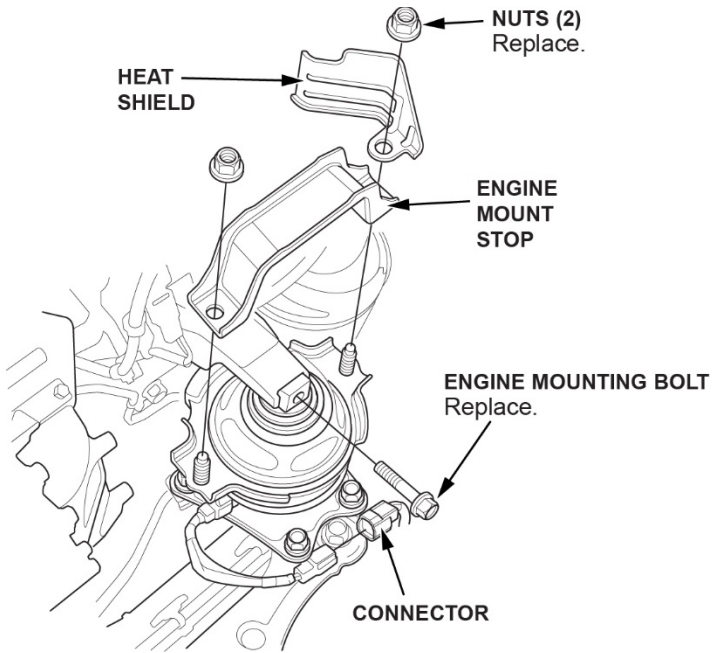

51. Loosely install the front engine mount stop and the front engine mount mounting bolt.

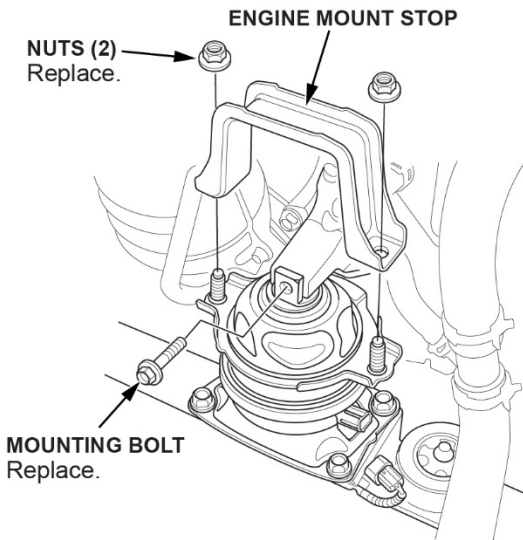

52. Tighten the engine/transmission mounts in the following sequence:

Sequence	Mount Description
1	Front Engine Mount
2	Rear Engine Mount
3	Transmission Mount
4	Side Engine Mount

1. Tighten the front engine mount to the specified torque in sequence:

- Torque the engine mounting bolt to **54 N·m (40 lb-ft)**.
- Torque the engine mount stop nuts to **74 N·m (55 lb-ft)**.

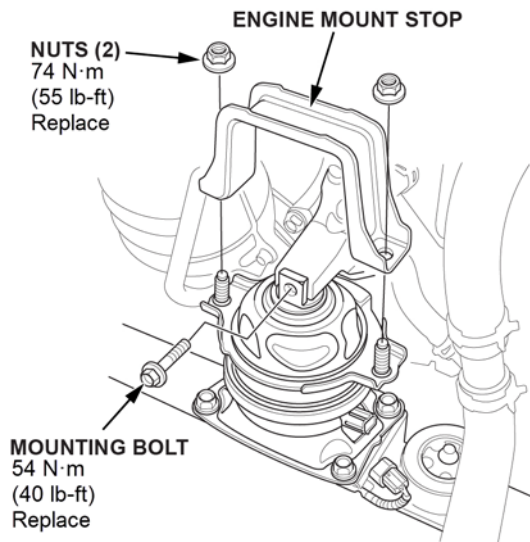

2. Tighten the rear engine mount to the specified torque in sequence:

- Torque the engine mounting bolt to **54 N·m (40 lb-ft)**.
- Torque the engine mount stop nuts to **74 N·m (55 lb-ft)**.

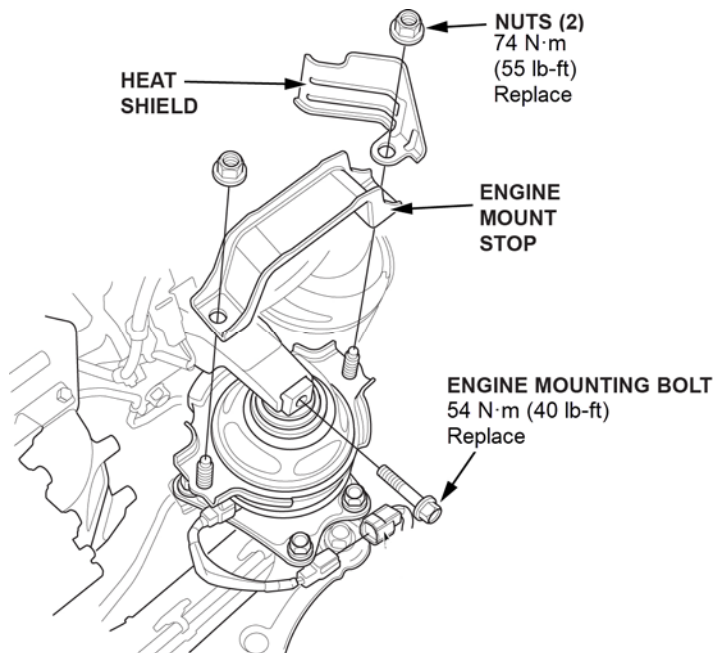

3. Tighten the transmission mount bolt to **54 N·m (40 lb-ft)**.

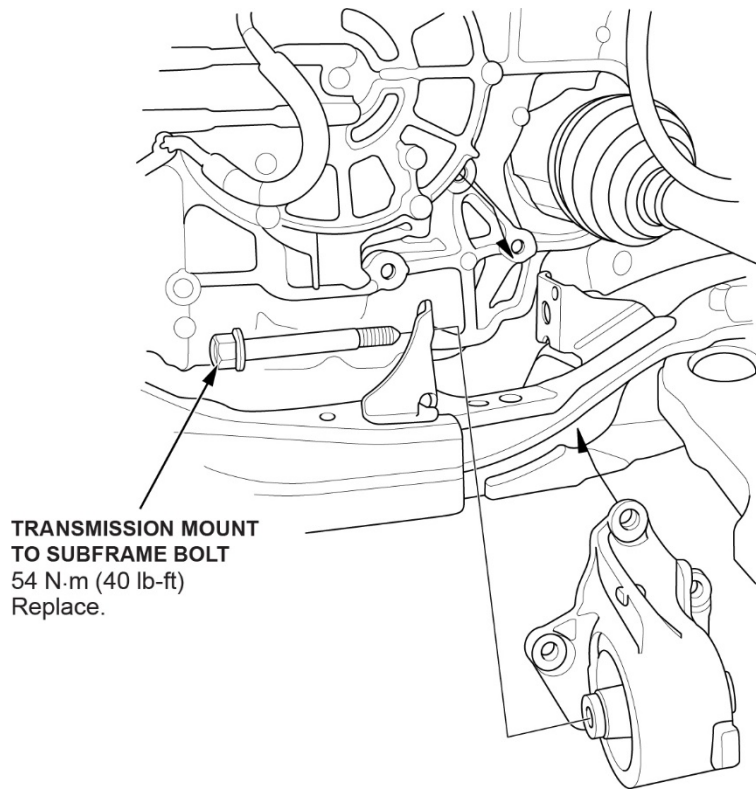

4. Tighten the side engine mount bolts to the specified torque.:

- Tighten the #2 bolts to **44 N·m (32 lb-ft)**.
- Tighten the #3 bolt to **64 N·m (47 lb-ft)**.

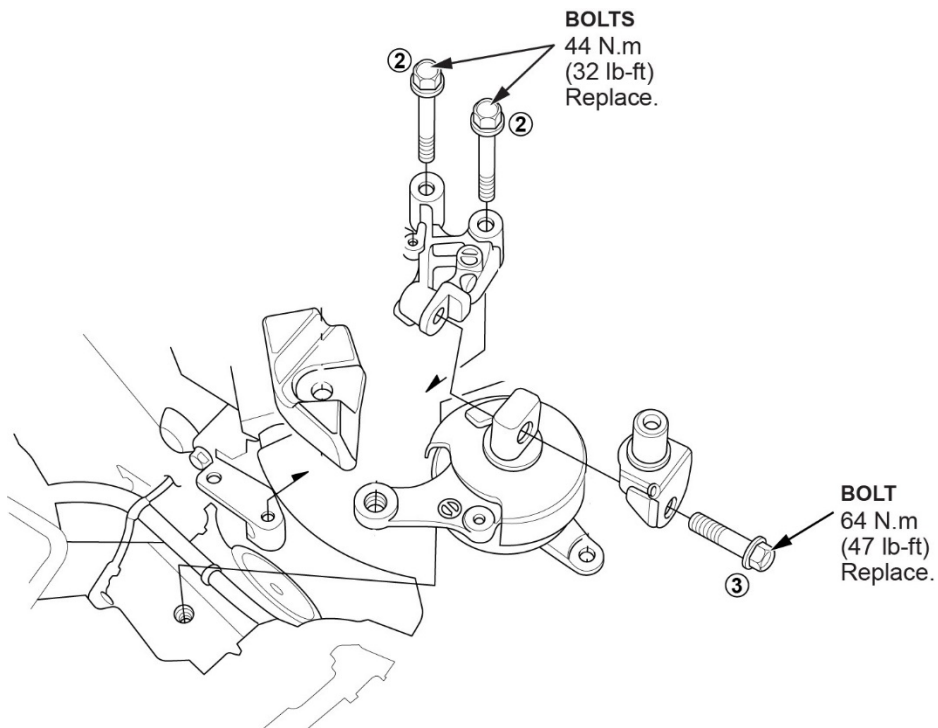

53. Install the transmission undercover.

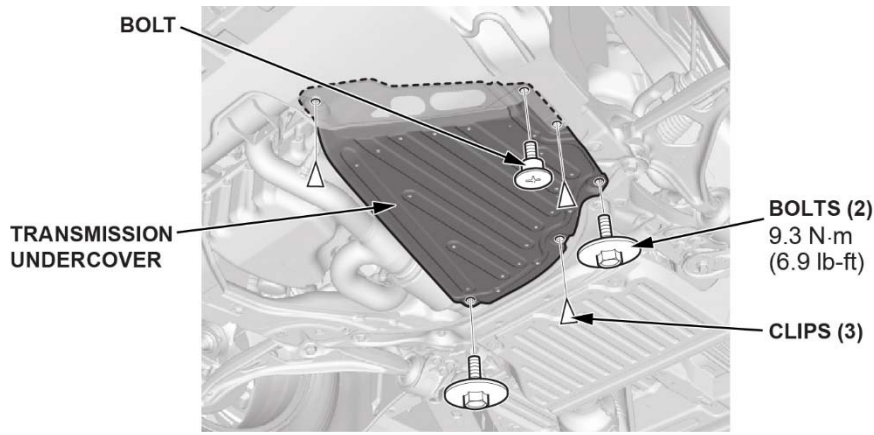

54. Install the engine undercover.

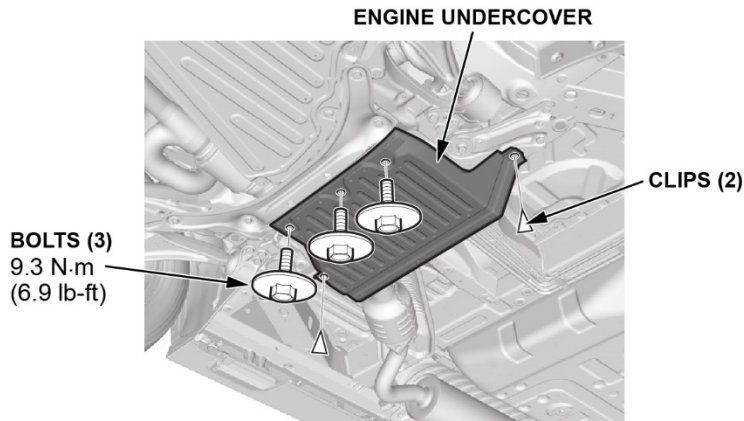

55. Install the splash shield.

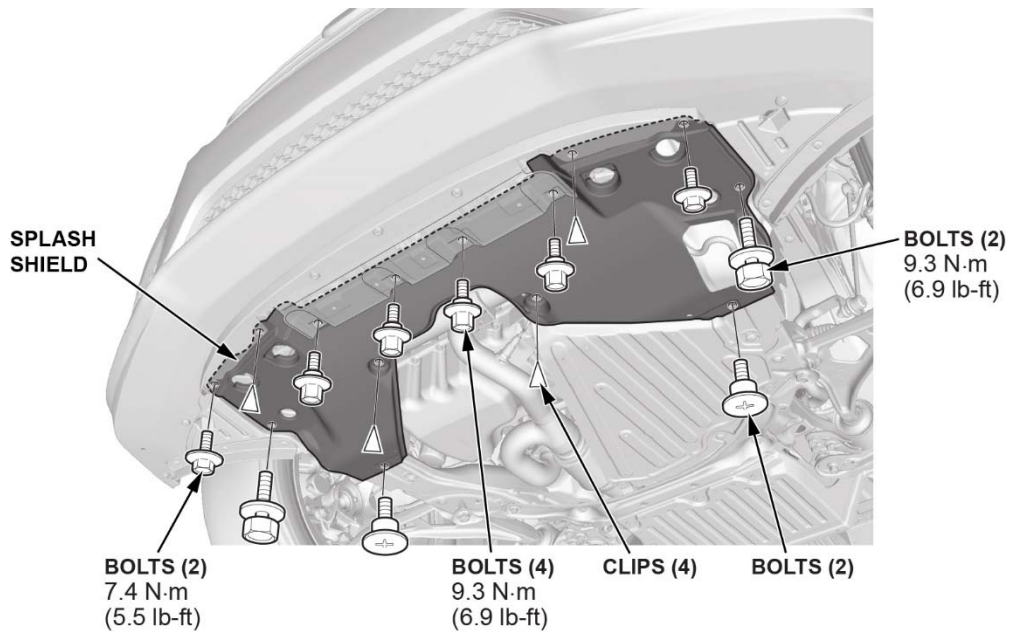



56. Install the front wheels.

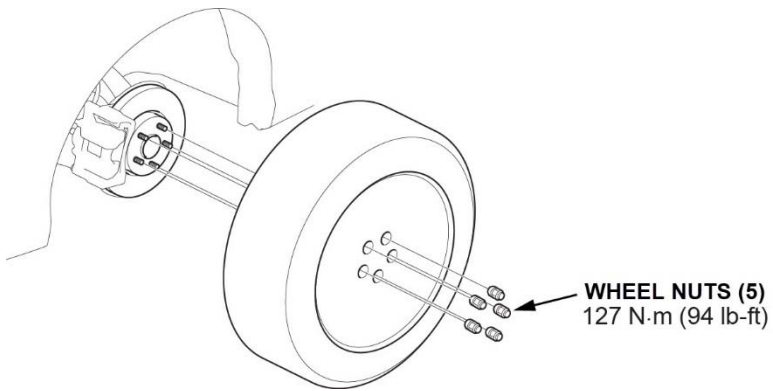

57. Lower the vehicle.

58. Connect the steering joint.

- If the center guide is still on the pinion shaft, align the steering joint to the center guide.

If the pinion shaft does not have a center guide:

- Position the steering column by aligning the gap within the angle.
- Align the bolt hole on the steering joint with the groove around the pinion shaft.

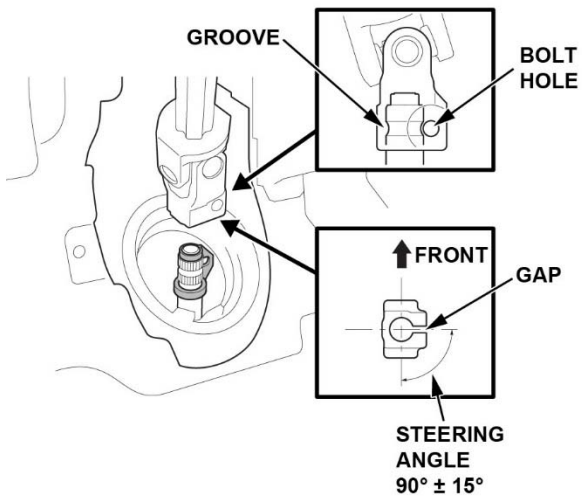

59. Install the steering joint bolt and cover.

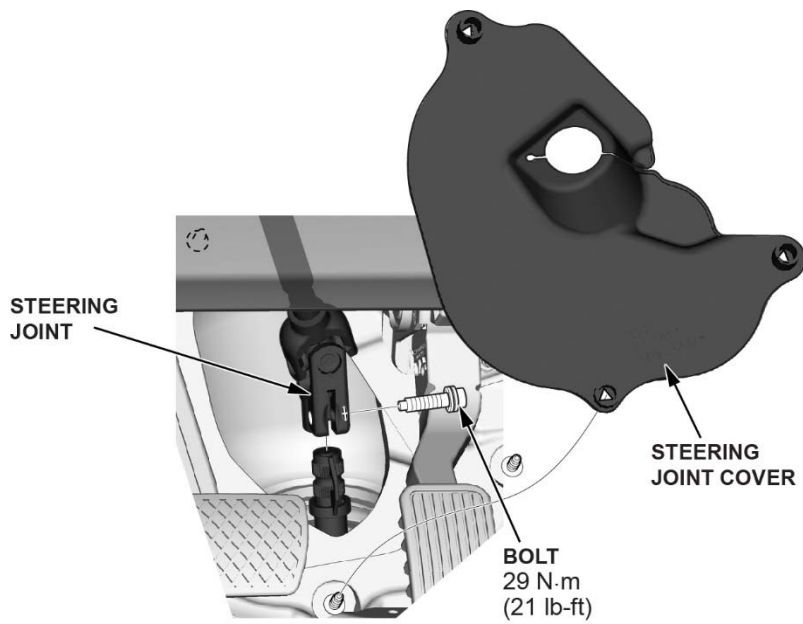

60. Install the driver's side center console side panel.

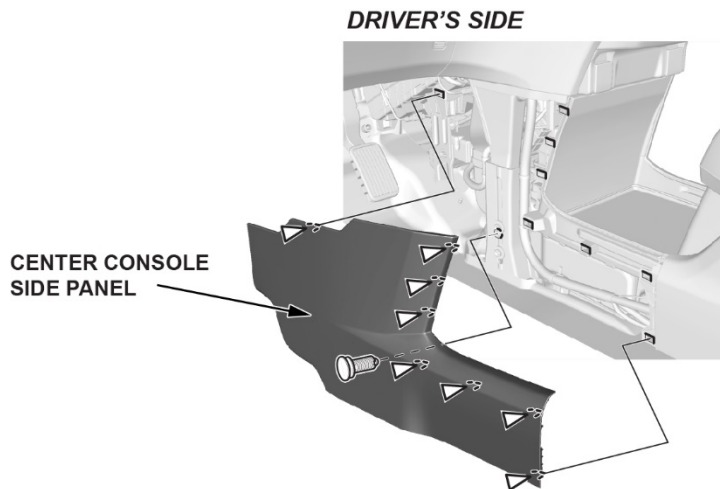

61. Connect the negative cable to the 12-volt battery.

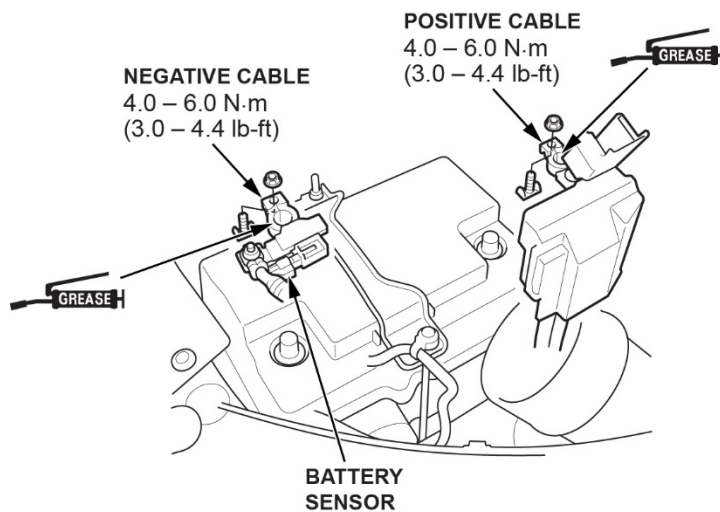

62. Install the cowl cover.

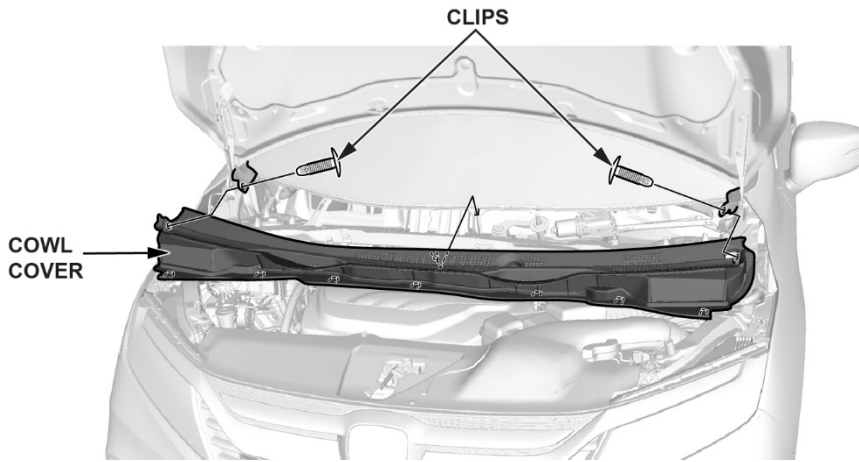

63. Install the windshield wiper arms.

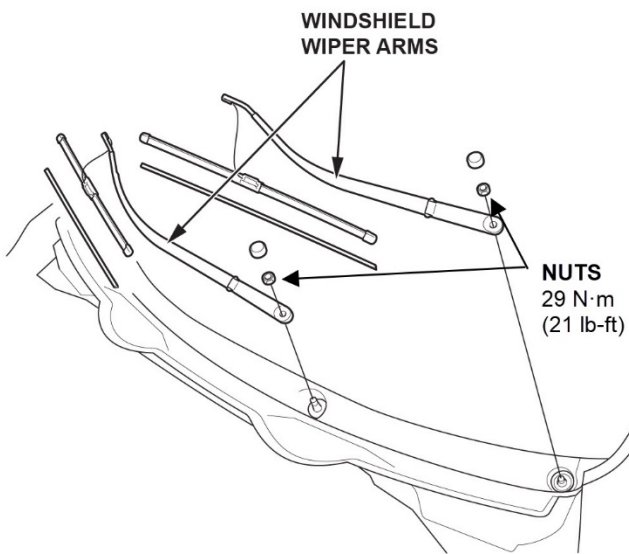

64. Install the **No. 6 cylinder** ignition coil.

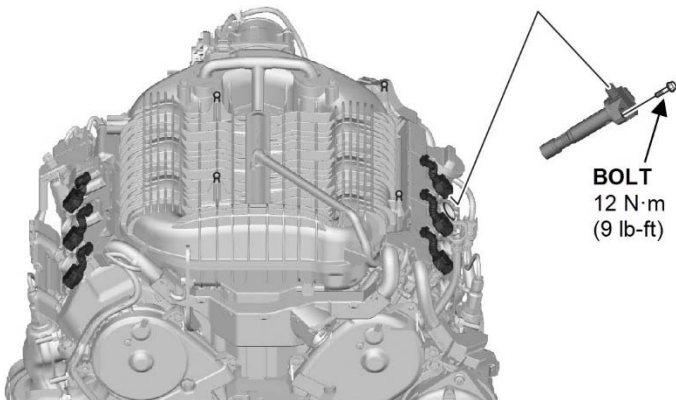

65. Install the air intake duct and air guide.

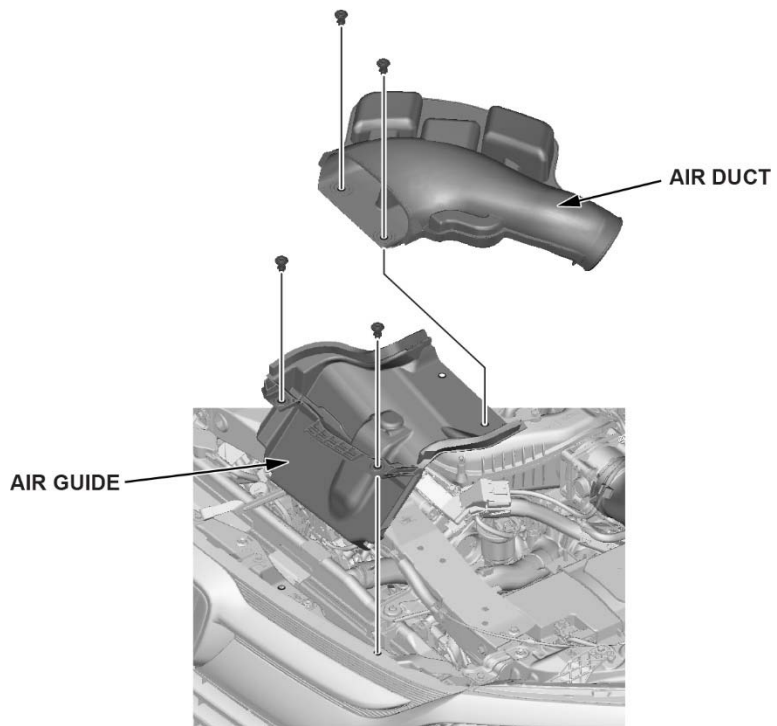

66. Install the front bulkhead cover.

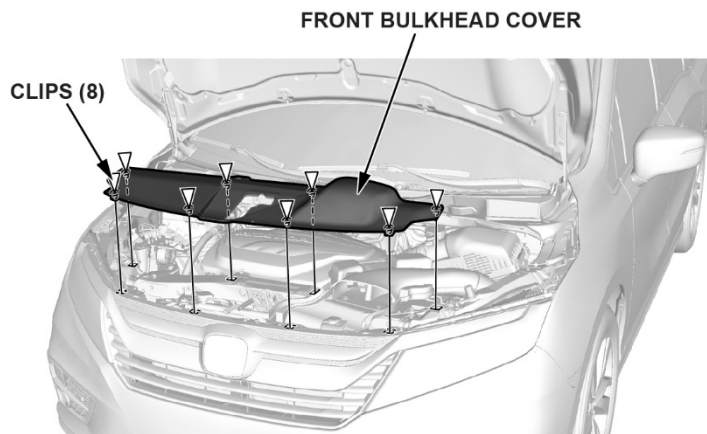

67. Install the engine cover.

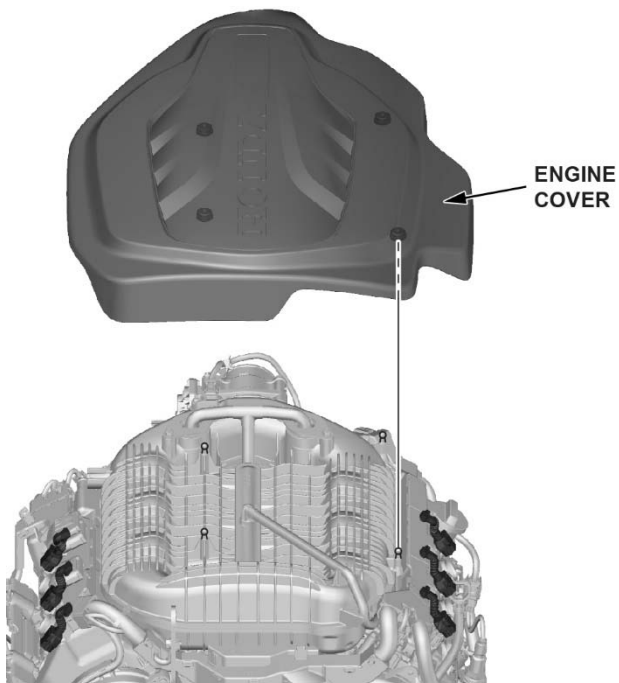

68. Update the EPS control unit.

1. Connect the i-HDS to the data link connector (DLC) located under the driver's side of the dashboard.



2. Follow the prompts to update the EPS control unit.

69. Do a wheel alignment.

70. Torque the tie rod locknut to specification (both sides).

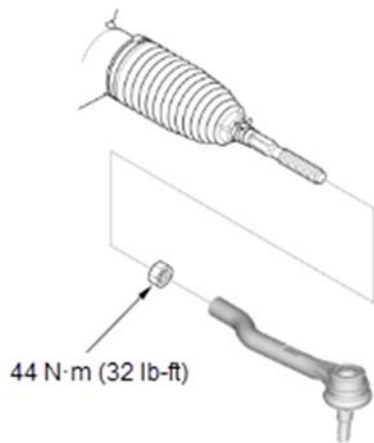

71. Do a steering gearbox after-installation check.

- With the front wheels straight ahead, make sure the steering wheel is centered and the turning revolutions from center to full lock (left and right) is equal. If not, check the installation of the steering wheel and the engagement of the joint/pinion shaft splines.
- With the tires raised off the ground, check for noise and abnormality by turning the steering wheel fully to the right and left several times.

72. Do a power steering assist check:

1. Start the engine and let it idle.
2. Attach a commercially available spring scale to the steering wheel.
3. With the engine idling and the vehicle on a clean, dry floor, pull the scale as shown and read it as soon as the tires begin to turn.
4. The amount of force measured should not exceed **34 N (7.6 lbf)**.



73. Check that the EPS indicator does not come on.

74. Do the VSA Sensor Neutral Position Memorization procedure:

NOTE: Do not press the brake pedal during this procedure.

1. Turn the vehicle to the OFF mode.
2. Connect the i-HDS to the data link connector (DLC) located under the driver's side of the dashboard.
3. Turn the vehicle to the ON mode, but do not start the engine.
4. Activate the i-HDS, then make sure the HDS communicates with the PCM and other vehicle systems. If it doesn't, go to the DLC circuit troubleshooting.
5. Set the steering wheel in the straight-ahead position.
6. Select **ADJUSTMENT > ABS/TCS/VSA > ALL SENSOR**, and follow the screen prompts.