



Safety Recall

Code: 20UF

Subject Suction Jet Pump

Document History

Date	Summary
08/07/2024	Updated claiming instructions
08/06/2024	Original publication

Affected Vehicles

Country	Beginning Model Year	Ending Model Year	Vehicle	Vehicle Count
USA	2015	2020	GOLF	58,544
USA	2015	2020	GOLF GTI	114,485
USA	2015	2019	GOLF SPORTWAGEN	26,037
USA	2019	2020	JETTA GLI	10,925
CAN	2015	2019	GOLF	57,293
CAN	2015	2020	GOLF GTI	15,783
CAN	2015	2019	GOLF SPORTWAGEN	8,689
CAN	2019	2020	JETTA GLI	1,558

Check Campaigns/Actions screen in ELSA on the day of repair to verify that a VIN qualifies for repair under this action. ELSA is the only valid campaign inquiry & verification source.

- ✓ Campaign status must show "open."
- ✓ If ELSA shows other open action(s), inform your customer so that the work can also be completed at the same time the vehicle is in the workshop for this campaign.

Problem Description

The suction jet pump inside the fuel tank is designed to purge fuel from the Evaporative Emissions (EVAP) system. If a specific seal inside an affected suction jet pump fails, the fuel may flow directly into the EVAP system. If this happens, fuel could accumulate in the EVAP system and may leak through the charcoal canister filter element. Leaking fuel, in the presence of an ignition source, may result in a fire.

Corrective Action

Replace the suction jet pump.

Precautions

If the recall condition exists in the vehicle, customers could experience refueling issues (early stopping fuel nozzles, spillback) when fuel has accumulated in the EVAP system. A fuel odor may also be noticed by the driver/vehicle occupants. Customers experiencing these issues are advised to contact an authorized dealer to have the vehicle diagnosed.

Code Visibility

On February 16, 2024, the campaign code was applied to affected vehicles.

Owner Notification

Owner notification will take place in August 2024. Owner letter examples are included in this bulletin for your reference.

Additional Information

Please alert everyone in your dealership about this action, including Sales, Service, Parts and Accounting personnel. Contact Warranty if you have any questions.

IMPORTANT REMINDER ON VEHICLES AFFECTED BY SAFETY & COMPLIANCE RECALL

New Vehicles in Dealer Inventory: It is a violation of federal law for a dealer to deliver a new motor vehicle or any new or used item of motor vehicle equipment (including a tire) covered by this notification under a sale or lease until the defect or noncompliance is remedied. By law, dealers must correct, prior to delivery for sale or lease, any vehicle that fails to comply with an applicable Federal Motor Vehicle Safety Standard or that contains a defect relating to motor vehicle safety.

Pre-Owned Vehicles in Dealer Inventory: Dealers should not deliver any pre-owned vehicles in their inventory which are involved in a safety or compliance recall until the defect has been remedied.

Dealers must ensure that every affected inventory vehicle has this campaign completed before delivery to consumers.

Fill out and affix Campaign Completion Label (CAMP 010 000) after work is complete. *Labels can be ordered at no cost via the Compliance Label Ordering portal at www.vwhub.com.*

Parts Information

Criteria	Quantity	Part Number	P.O.C. Part Description	Ordering Method (see description below)
01	1	5Q0-201-029-A	PUMP	UOL
	2	5GM-886-373	GROMMET	Free Order
	1	1J0-919-133-B	SEAL	Free Order

Parts Control Type: Upper Order Limit (UOL)	Parts will be managed with a weekly Upper Order Limit. Please see Parts On Command (POC) for your Upper Order Limit quantity.
--	---

Parts Control Type: Free Order	Parts will be managed by Free Order
---	-------------------------------------

Initial Allocation: YES	Dealers will be sent an initial allocation prior to customer notification. If no initial allocation was received, please reference your dealer's Estimated Remaining Repairs by campaign to view your potential VIN population.
--	---

NOTE

Your dealer's Estimated Remaining Repairs by campaign can be found in Parts on Command. Click on "View Campaign List" and review the Estimated Remaining Repairs column.

NOTE

Campaign parts should always be ordered as per the parts information in this circular. The ordering system will supersede the part, if applicable.

Claim Entry Instructions

The labor times listed here may differ from the labor operations and labor times listed in ELSA.

After campaign has been completed, enter claim as soon as possible to help prevent work from being duplicated elsewhere. Attach the ELSA screen print showing action open on the day of repair to the repair order.

If a customer declines campaign work, refer to the "Customer Declines Campaign/Update Repair" section in the Campaign/Update Policy and Procedures Manual.

Service Number	20UF		
Damage Code	0099		
Parts Vendor Code	WVO		
Claim Type	Sold vehicle: 7 10 Unsold vehicle: 7 90		
Causal Indicator	Mark PUMP* as causal part		
Vehicle Wash/Loaner	Do not claim wash/loaner under this action. Loaner/rental coverage cannot be claimed under this action. However, loaner/rental may be covered under the current loaner/mobility program. Please refer to the Volkswagen Warranty Policy and Procedures Manual for loaner claims information and reimbursement details.		
Criteria I.D.	01		
	LABOR		
	Labor Op	Time Units	Description
	2066 19 00	SEE ELSA	Remove and install fuel delivery unit
	2003 17 50	SEE ELSA	Fuel drained+filled
	2050 19 99	20	Replace suction jet pump
	PARTS		
	Quantity	Part Number	Description
	1.00	1J0919133B	SEAL RING
	2.00	5GM886373	GROMMET
	1.00	5Q0201029A	PUMP*

Customer Letter Example (USA)

<MONTH YEAR>

<CUSTOMER NAME>

<CUSTOMER ADDRESS>

<CUSTOMER CITY STATE ZIPCODE>

This notice applies to your vehicle: <MODEL YEAR> <BRAND> <CARLINE>, <VIN>

NHTSA: 24V110

Subject: Safety Recall 20UF - Suction Jet Pump

Dear Volkswagen Owner,

This notice is sent to you in accordance with the National Traffic and Motor Vehicle Safety Act. Volkswagen has decided that a defect, which relates to motor vehicle safety, exists in certain 2015-2020 model year Volkswagen vehicles. Our records show that you are the owner of a vehicle affected by this action.

What is the issue?

The suction jet pump inside the fuel tank is designed to purge fuel from the Evaporative Emissions (EVAP) system. If a specific seal inside an affected suction jet pump fails, the fuel may flow directly into the EVAP system. If this happens, fuel could accumulate in the EVAP system and may leak through the charcoal canister filter element. Leaking fuel, in the presence of an ignition source, may result in a fire.

What will we do?

To correct this defect, your authorized Volkswagen dealer will replace the suction jet pump. This work will take about two hours to complete and will be performed for you free of charge. Please keep in mind that your dealer may need additional time for the preparation of the work, as well as to accommodate their daily workshop schedule.

What should you do?

Please contact your authorized Volkswagen dealer without delay to schedule this recall work. To set up an appointment online, please visit www.vw.com/find-a-dealer.

On the day of repair, if possible, please ensure that the fuel level in your vehicle is at ¼ of a tank (or less).

Precautions you should take:

If the recall condition exists in the vehicle, customers could experience refueling issues (early stopping fuel nozzles, spillback) when fuel has accumulated in the EVAP system. A fuel odor may also be noticed by the driver/vehicle occupants. Customers experiencing these issues are advised to contact an authorized dealer to have the vehicle diagnosed.

Additional Information

- If you are the lessor and registered owner of the vehicle identified in this action, the law requires you to forward this letter immediately via first-class mail to the lessee within ten (10) days of receipt.
- If your authorized Volkswagen dealer fails or is unable to complete this work free of charge within a reasonable time, if you have changed your address or sold the vehicle, or if you should have any questions about this communication, please reach out to us using your preferred method of communication at www.vw.com/contact or by calling us at 800-893-5298.
- If you still cannot obtain satisfaction, you may file a complaint with: The Administrator, National Highway Traffic Safety Administration, 1200 New Jersey Avenue, SE., Washington, DC 20590; or call the toll-free Vehicle Safety Hotline at 1-888-327-4236 (TTY: 1-800-424-9153); or go to <http://www.safercar.gov>.
- To check your vehicle's eligibility for repair under this or any other recall/service campaign, please visit www.vw.com/owners/recalls and enter your Vehicle Identification Number (VIN) into the Recall/Service Campaign Lookup tool.
- If you have previously paid for repairs relating to the condition described in this letter, the enclosed form explains how to request reimbursement. We would be pleased to review your reimbursement request.

We apologize for any inconvenience this matter may cause; however, we are taking this action to help ensure your safety and continued satisfaction with your vehicle.

Sincerely,

Volkswagen Customer Protection

Customer Letter Example (Canada)

<MONTH YEAR>

<CUSTOMER NAME>

<CUSTOMER ADDRESS>

<CUSTOMER CITY STATE ZIPCODE>

This notice applies to your vehicle: <MODEL YEAR> <BRAND> <CARLINE>, <VIN>

Transport Canada Recall: 2024-095

Subject: Safety Recall 20UF - Suction Jet Pump

Dear Volkswagen Owner,

This notice is sent to you in accordance with the requirements of the *Motor Vehicle Safety Act*. This is to inform you that your vehicle may contain a defect that could affect the safety of a person. Our records show that you are the owner of a vehicle affected by this action.

What is the issue?

The suction jet pump inside the fuel tank is designed to purge fuel from the Evaporative Emissions (EVAP) system. If a specific seal inside an affected suction jet pump fails, the fuel may flow directly into the EVAP system. If this happens, fuel could accumulate in the EVAP system and may leak through the charcoal canister filter element. Leaking fuel, in the presence of an ignition source, may result in a fire.

What will we do?

To correct this defect, your authorized Volkswagen dealer will replace the suction jet pump. This work will take about two hours to complete and will be performed for you free of charge. Please keep in mind that your dealer may need additional time for the preparation of the work, as well as to accommodate their daily workshop schedule.

What should you do?

Please contact your authorized Volkswagen dealer without delay to schedule this recall work.

On the day of repair, if possible, please ensure that the fuel level in your vehicle is at ¼ of a tank (or less).

Precautions you should take:

If the recall condition exists in the vehicle, customers could experience refueling issues (early stopping fuel nozzles, spillback) when fuel has accumulated in the EVAP system. A fuel odor may also be noticed by the driver/vehicle occupants. Customers experiencing these issues are advised to contact an authorized dealer to have the vehicle diagnosed.

Additional Information

- If you are the lessor and registered owner of the vehicle identified in this letter, you shall forward this letter (and any subsequent notice, if applicable) to the lessee within ten (10) days of receipt.
- If your authorized Volkswagen dealer fails or is unable to complete this work free of charge within a reasonable time, if you have changed your address or sold the vehicle, or if you should have any questions about this communication, please contact please contact Customer Relations, Monday through Friday from 8AM to 8PM EST by phone at 1-800-822-8987 or via our "Contact Us" page at www.vw.ca.
- If you have previously paid for repairs relating to the condition described in this letter, the enclosed form explains how to request reimbursement. We would be pleased to review your reimbursement request.

We apologize for any inconvenience this matter may cause; however, we are taking this action to help ensure your safety and continued satisfaction with your vehicle.

Sincerely,

Volkswagen Customer Protection

Repair Overview





- Replace suction jet pump.

! NOTE

- These repair instructions may differ from the labor operations and labor times listed in ELSA.
- Damages resulting from improper repair or failure to follow these work instructions are the dealer's responsibility and are not eligible for reimbursement under this action.
- This procedure must be read in its entirety prior to performing the repair.
- Due to variations in vehicle equipment and options, the steps/illustrations in this work procedure may not identically match all affected vehicles.
- Diagnosis and repair of pre-existing conditions in the vehicle are not covered under this action.
- When working during extreme temperatures, it is recommended that the vehicle be allowed to acclimate inside the shop to avoid temperature-related component damage/breakage.

Required Tools

 <p>Wrench - Fuel Sending Unit -T10202-</p>	 <p>Trim Removal Wedge -3409- (or equivalent)</p>
 <p>Fuel Extracting Device -VAS5190A- (or equivalent)</p>	

Repair Instruction

Section A - Check for Previous Repair

Applicable criteria ID(s)	Campaign/Action Status
01 ← 2	Open ← 1

EXAMPLE

Campaign/Action	Start	Designation
← 3 →	2015-11-10	W-SERV_ACT -
	2018-12-13	RECALL -
	2017-05-16	A-RECALL -

EXAMPLE

- Enter the VIN in Elsa and proceed to the “Campaign/Action” screen.

TIP

On the date of repair, print this screen and keep a copy with the repair order.

- Confirm the Campaign/Action is open <arrow 1>. If the status is closed, no further work is required.
- Note the Applicable Criteria ID <arrow 2> for use in determining the correct work to be done and corresponding parts associated.

CRITICAL REPAIR STEP

 **STOP!** 

All campaigns/actions with a repair available must be performed in order of the Start date <arrow 3>. The oldest should be performed first (unless otherwise noted in the repair instructions).

Proceed to Section B.

Section B – Repair Procedure

NOTE

- Due to variations in vehicle equipment and options, the steps/illustrations in this work procedure may not identically match all affected vehicles.
- This procedure must be read in its entirety before performing the repair.

NOTE

Follow these “rules” when working on the fuel supply system:

- Thoroughly clean the connecting points and the surrounding area before loosening.
- Place the removed parts on a clean surface and cover them. Only use lint-free cloths!
- Carefully cover or seal opened components if the repair will not be done immediately.
- Only install clean parts: remove replacement parts from the packaging immediately prior to installation. Do not use parts that have been stored loose (for example, in tool boxes etc.).
- When the system is open: do not work with compressed air.
- Do not move vehicle.
- Seal off any open lines and connections immediately with plugs, for example, take from -VAS6122-.
- Protect the disconnected connectors from dirt and moisture and only connect when they are dry.
- Before starting work, place the extracting hose on an exhaust extractor that is switched on near the fuel tank assembly opening to extract fuel vapors.

WARNING

Risk for repeat repair!

It is imperative that the battery is disconnected before draining the fuel. Failing to disconnect the battery can result in fuel level sending unit faults, or fuel gauge inaccuracies. Additional diagnostic time required to perform a capacitive discharge or remove fused power to the instrument cluster to clear these faults or inaccuracies are NOT covered under this campaign.

Disconnect the 12V battery:

- Move the front seats all the way forward.
- On vehicles equipped with power seats, be sure to move the front seats all the way forward before disconnecting the battery in the next step.
- Open the battery heat protection sleeve cover to access the cover <1> on the battery ground terminal <2>.
- Loosen the nut <3> several turns and remove the battery ground terminal <2> from the negative battery post and isolate the terminal.

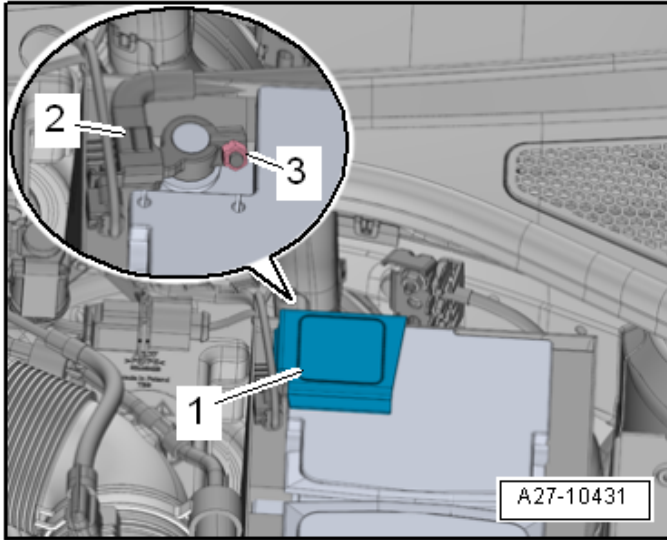

Remove the rear bench seat:

- See ELSA Repair Manual: *Repair Manual > Body > Body Interior > 72 Seat Frames > Rear Seats > Bench Seat/Single Seat, Removing and Installing*

! NOTE

Place the seat bench in a clean location where it will not be damaged. Damage to the seat bench is not covered under this action.

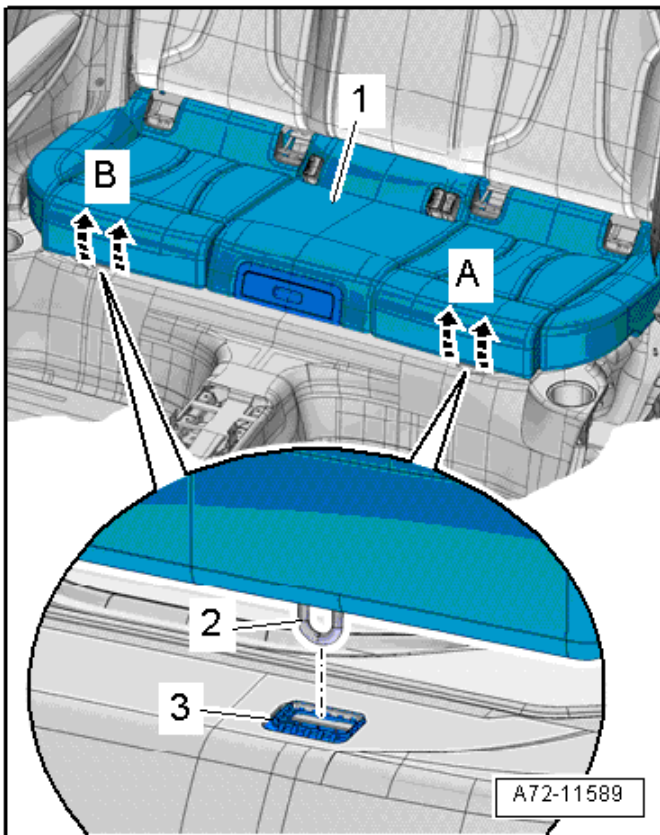

⚠ WARNING

Risk for repeat repair!

It is imperative that the exact amount of fuel removed from the fuel tank is reinstalled into the fuel tank at the end of this operation. Failing to reinstall the same amount of fuel that was extracted can result in fuel level sending unit faults, or fuel gauge inaccuracies. Additional diagnostic time required to perform a capacitive discharge or remove fused power to the instrument cluster to clear these faults or inaccuracies are NOT covered under this campaign.

Reimbursement of fuel costs will not be covered under this campaign.

⚠ WARNING

Danger due to fuel contacting skin

- To prevent injury or discomfort, wear proper protective gear when skin may come in contact with fuel. Proper fuel resistant gloves are advised.
- Take care when working on a vehicle that has been stored outdoors in extreme climate conditions. Fuel will not freeze when exposed to extreme cold, therefore the fuel in the tank may be well below 0°C. Use cold weather protective gear or equipment as necessary, drain all of the fuel out, or warm the vehicle indoors if the vehicle has been stored in an extreme climate condition before performing the next steps.

⚠ CAUTION

There is a risk of injury due to the fuel being under pressure.

The fuel system is under pressure. Injuries are possible from fuel spraying out.

Before opening the fuel system:

- Wear protective eyewear.
- Wear safety gloves.
- Reduce the pressure: place clean cloths around the connection point and carefully open the connection point.

⚠ CAUTION

Leaking fuel increases the risk of fire.

When the battery is connected, the door contact switch activates the fuel pump when opening the driver door. Leaking fuel may ignite and start a fire.

Before opening the fuel system, cut off the power supply to the fuel pump.

⚠ CAUTION

Perform the following steps before starting work on the fuel system:

Before starting work, switch on the exhaust extracting system and place a suction hose close to the installation opening of the fuel tank to extract escaping fuel fumes.

If no exhaust extracting system is available, a radial fan (as long as motor is not in air flow) with a delivery volume greater than 15 m³ (49.2 feet³)/h can be used.

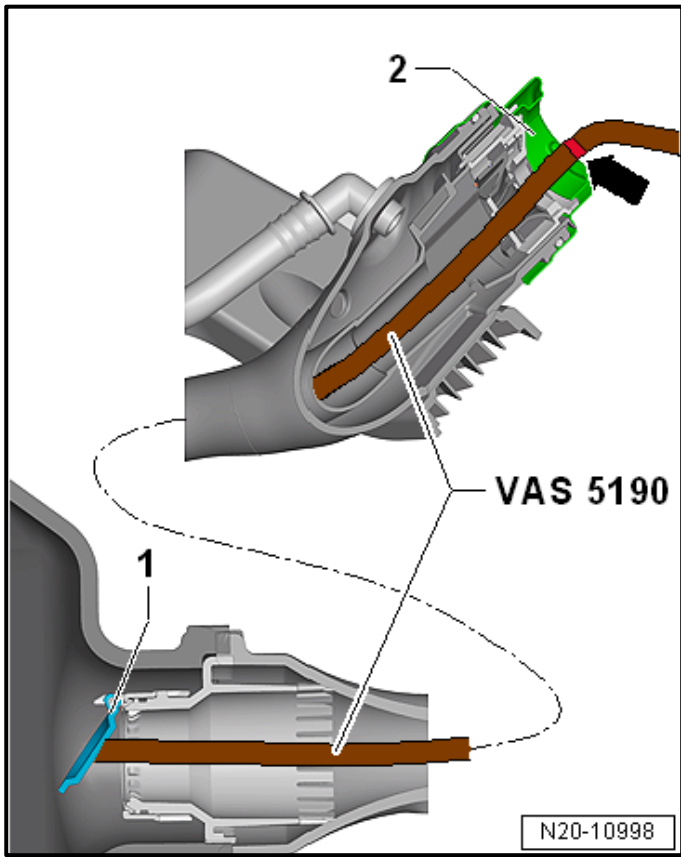

Drain the fuel tank:

⚠ WARNING

Risk for repeat repair!

- It is imperative that the exact amount of fuel removed from the fuel tank is reinstalled into the fuel tank at the end of this operation.
- Failing to reinstall the same amount of fuel that was extracted can result in fuel level sending unit faults, or fuel gauge inaccuracies.
- Additional diagnostic time required to perform a capacitive discharge or remove fused power to the instrument cluster to clear these faults or inaccuracies are NOT covered under this campaign.

- See ELSA Repair Manual: *Repair manual > Engine > Fuel Supply - Gasoline Engines > 20 Fuel Supply > Fuel Tank > Fuel Tank, Draining*

ⓘ NOTE

Risk for repeat repair!

- Do not use pliers or other tools on the fuel line connector(s) or damage to the connector may occur.
- Damage to the fuel line connector(s) due to improper removal/installation may cause the connector to not fasten securely upon reinstallation, causing a leak.
- Consequential damage to the fuel line connector(s) due to improper removal/installation is not covered under this campaign.

ⓘ NOTE

- Follow all waste disposal regulations.
- Check the fuel tank for contamination.



- Prior to disassembly, the fuel delivery unit **MUST** be clean. If excessive dirt or debris is present <as shown>, clean and dry the fuel delivery unit and surrounding areas as necessary.

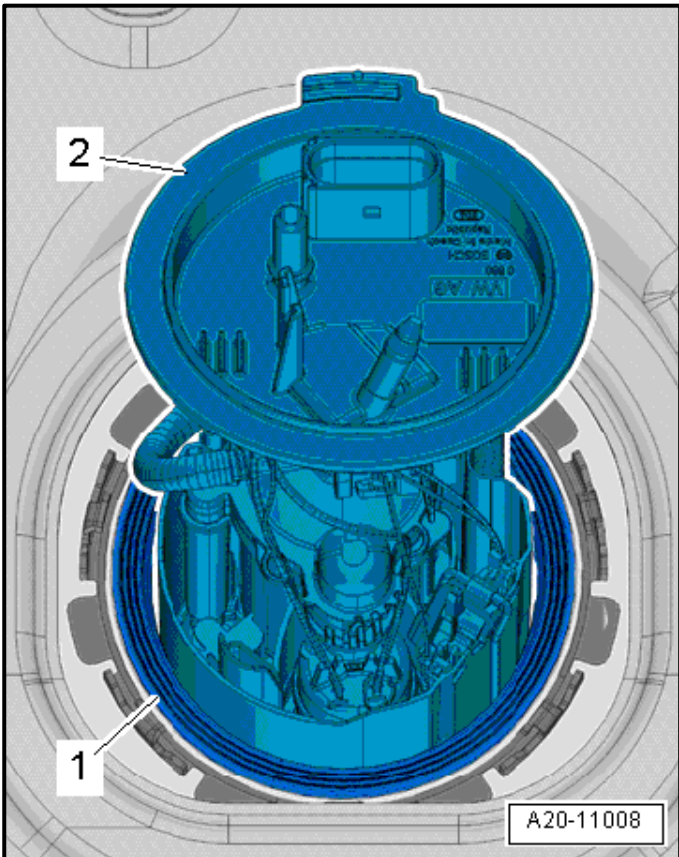

Remove the fuel delivery unit:

- See ELSA Repair Manual: *Repair manual > Engine > Fuel Supply - Gasoline Engines > 20 Fuel Supply > Fuel Delivery Unit/Fuel Level Sensor > Fuel Delivery Unit/Fuel Level Sensor, Removing and Installing,*

CAUTION

Risk for repeat repair!

During removal of the fuel delivery unit, it is very easy to damage the fuel level sensor. Use caution when removing the fuel delivery unit. Damage to the fuel level sensor is not covered under this action.



Replacing the suction jet pump:

TIP

- To view a short video overview on removing and reinstalling the suction pump, scan the QR code to the left.
- The QR code is for viewing the video on smartphones and tablets. Alternatively, the video can also be accessed through computer internet browsers with the link below:

<https://wvcup.lxp.live/training-library/dc74b9ac-30c6-4647-9bd4-2010a55135e6>

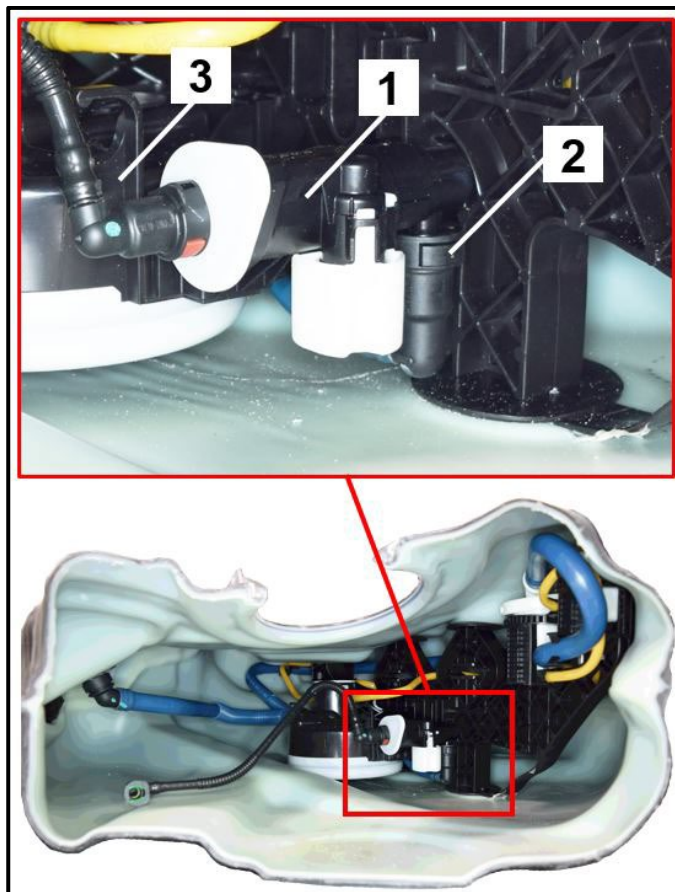

NOTE

- The fuel tank in the illustration below has been sectioned to provide a clear view of the suction valve.
- Under no circumstances should the fuel tank be altered or modified as shown below.
- Reach into the fuel tank and follow the black hose to find the suction pump <1>.
- Disconnect the rear suction line <2>:
 - Push the connector further onto the suction pump.
 - Press and hold the quick release connector latch in with the thumb.
 - Pull the connector off (downward).

NOTE

Risk for repeat repair!

- Do not use pliers or other tools on the fuel line connectors <2 and 3> or damage to the connector may occur.
- Damage to the fuel line connector(s) due to improper removal/installation may cause the connector to not fasten securely upon reinstallation, causing a leak. A damaged fuel line connector on the front or rear suction pump line requires replacement of the FUEL TANK.
- Consequential damage to the fuel tank due to connector damage from improper removal/installation is not covered under this campaign.

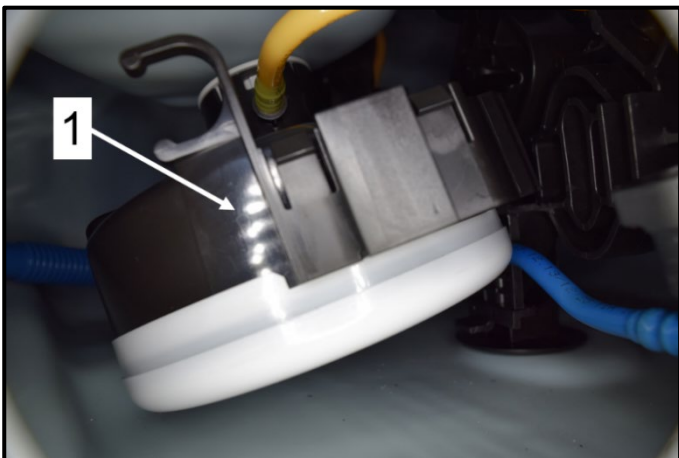
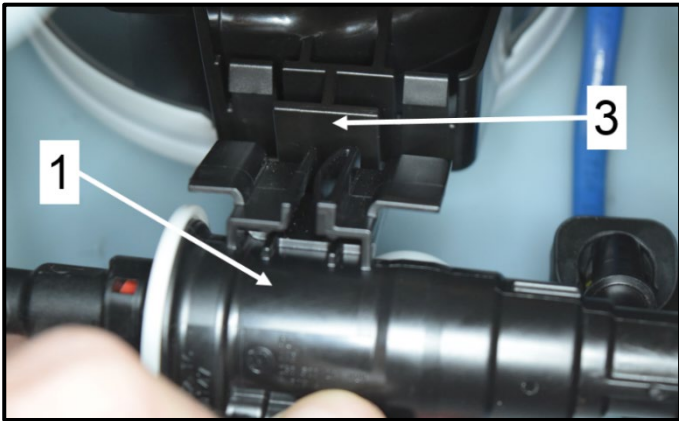
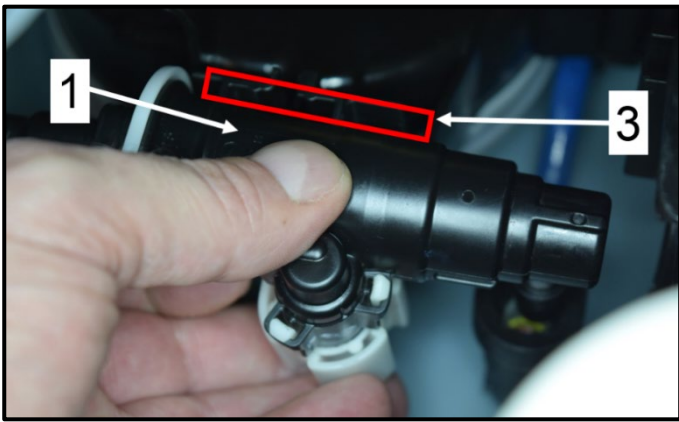

- Remove the suction pump <1> off the retainer bracket <3>:
 - Slightly rotate suction pump <1> away from the bracket <3>
 - Remove the pump <1> from the fuel tank by gently rocking it back and forth between the fingers and thumb.
 - Use caution not to damage the attached front suction line.

- Take care that the Liquid-Vapor Separator Assembly <1> does not come off of its attachment bracket when removing the Suction Jet Pump.

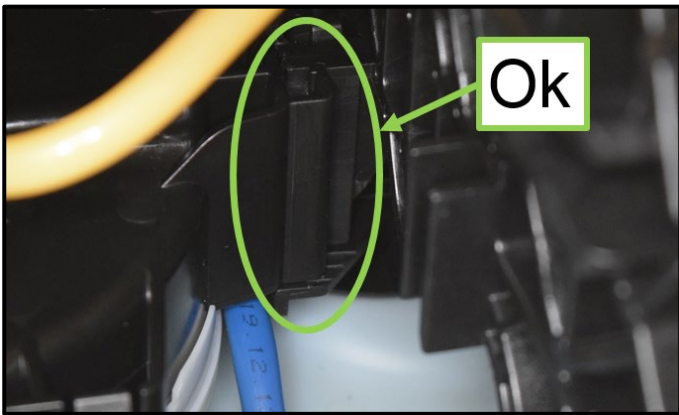
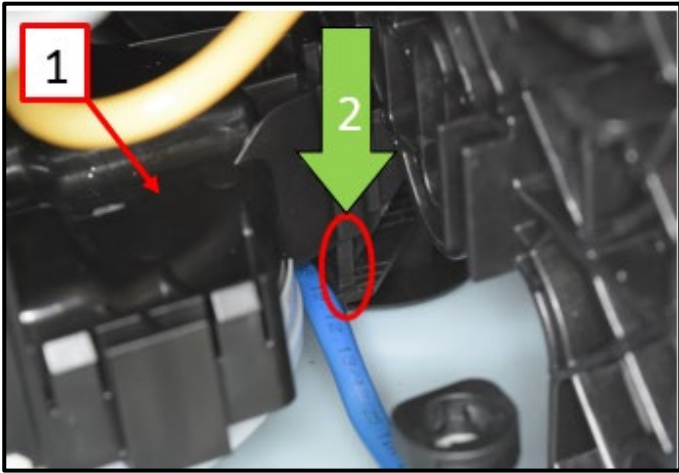
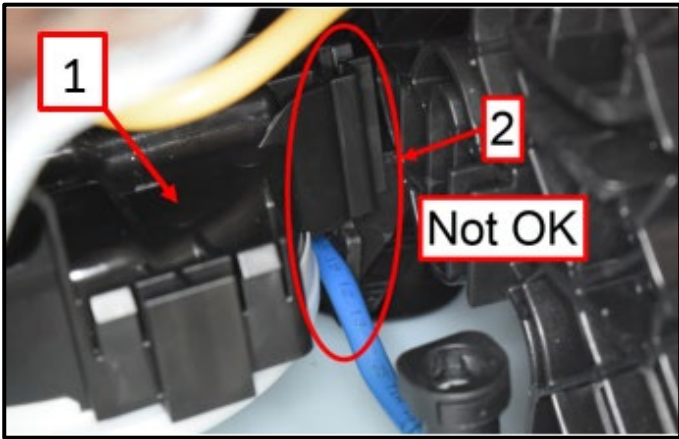

NOTE

Risk for repeat repair!

- If the Liquid-Vapor Separator <1> comes loose and is not reinstalled onto the mounting bracket, a customer comeback for rattling in the fuel tank, or EVAP system faults may occur.
- The Liquid-Vapor Separator <1> can be reinstalled onto its mounting bracket <2>.
- Replacement of the fuel tank for the Liquid-Vapor Separator dislodging from the mounting bracket is not covered under this campaign.

- If the Liquid-Vapor Separator Assembly <1> comes off the mounting bracket during suction pump removal:
 - Snap the Liquid-Vapor Separator <1> back into place by realigning it with the mounting bracket.
 - Push down on the Liquid-Vapor Separator to reengage the clip <2>.

- When correctly installed, the Liquid-Vapor Separator clip will be secured into its mounting bracket as shown.

NOTE

- The fuel tank does NOT require replacement if the Liquid-Vapor Separator Assembly is dislodged from its mounting bracket during removal of the Suction Jet Pump.
- Consequential damage for fuel tank replacement is not covered under this campaign for dislodged Liquid-Vapor Separator Assemblies.

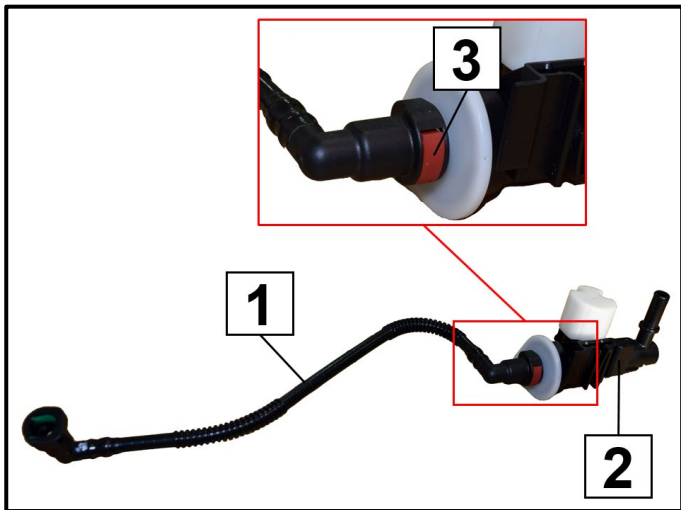

- Disconnect the front suction line <1> from the suction pump:
 - Push the front suction line <1> further onto the suction pump <2>.
 - Press the release <3> with the thumb, then pull the front suction line <3> off of the suction pump <2>.
- Transfer the front suction line <1> from the old suction pump <2> to the new suction pump, ensuring that the locking of the retention clip <3> is felt and/or heard.

i TIP

- The red colored connector <3> on the front suction line connects to the suction pump.
- The green colored connector on the front suction line connects to the fuel delivery unit.

! NOTE

Risk for repeat repair!

- Do not use pliers or other tools on the fuel line connector <3> or damage to the connector may occur.
- Damage to the fuel line connector due to improper removal/installation may cause the connector to not fasten securely upon reinstallation, causing a leak. A damaged fuel line connector on the suction pump line requires replacement of the FUEL TANK.
- Consequential damage to the fuel tank due to connector damage from improper removal/installation is not covered under this campaign.

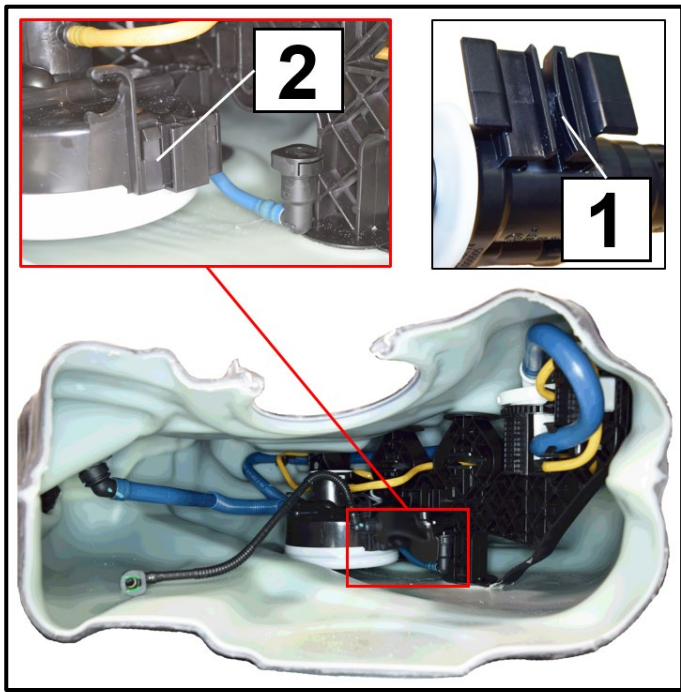

- Insert the new suction pump <1> into the fuel tank.
- Align the retention clip on the new suction pump <1> to the bracket <2> on the liquid-vapor separator.
- Slide the new suction pump <1> downward onto the bracket <2>.
- Ensure that the pump is secured firmly on the bracket <2>.

Part Number	Part Description
5Q0-201-029-A	Suction Pump

NOTE

Use caution not to damage the attached front suction line during installation.

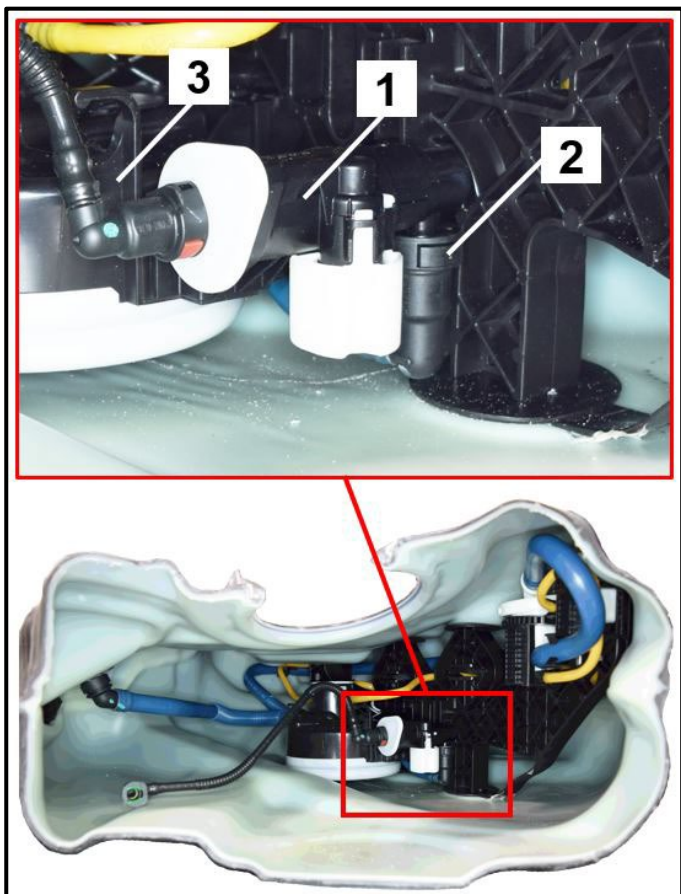

- Reconnect the rear suction line <2> to the suction pump <1>, ensuring that the locking of the retention clip is felt and/or heard.
- Ensure that the front suction line <3> and rear suction line <2> are firmly seated and secure by gently pulling the lines away from the suction pump.

NOTE

Risk for repeat repair!

- Do not use pliers or other tools on the fuel line connectors <2 and 3> or damage to the connector may occur.
- Damage to the fuel line connector(s) due to improper removal/installation may cause the connector to not fasten securely upon reinstallation, causing a leak. A damaged fuel line connector on the front or rear suction pump line requires replacement of the FUEL TANK.
- Consequential damage to the fuel tank due to connector damage from improper removal/installation is not covered under this campaign.

Reassemble vehicle in the reverse order of removal according to the ELSA repair manual and note the following:

- When reconnecting fuel lines, ensure that the locking of the retention clip is felt and/or heard.

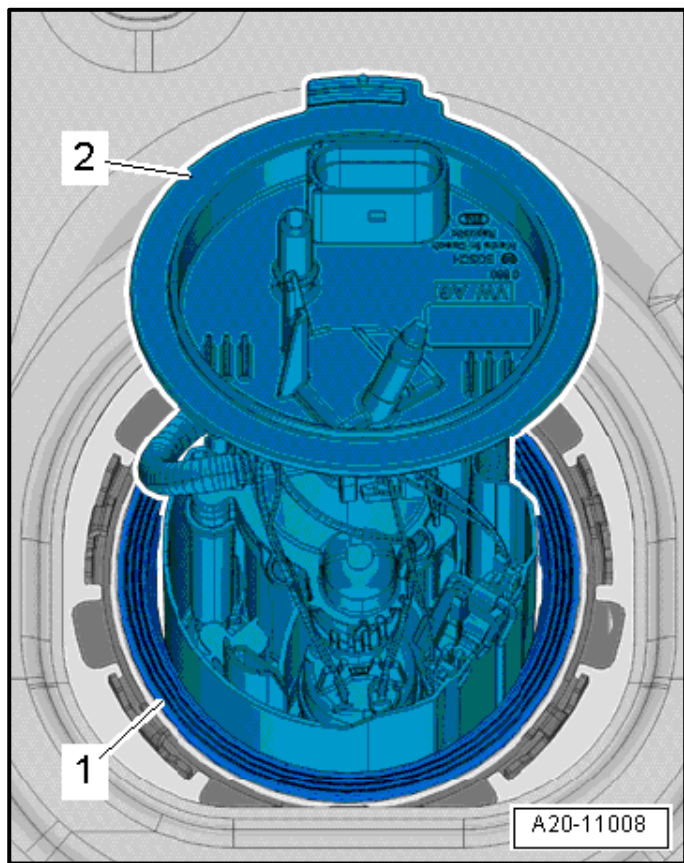

CAUTION

Risk for repeat repair!

- Be careful not to bend the fuel level sensor when installing the fuel delivery unit.
- Consequential damage to the fuel level sensor is not covered under this campaign.

- Carefully install the dry fuel delivery unit seal <1> into the opening in the fuel tank.

Part Number	Part Description
1J0-919-133-B	Seal

NOTE

The fuel delivery unit seal must be installed dry.



- Using the -T10202-, tighten the locking ring to 110 Nm.

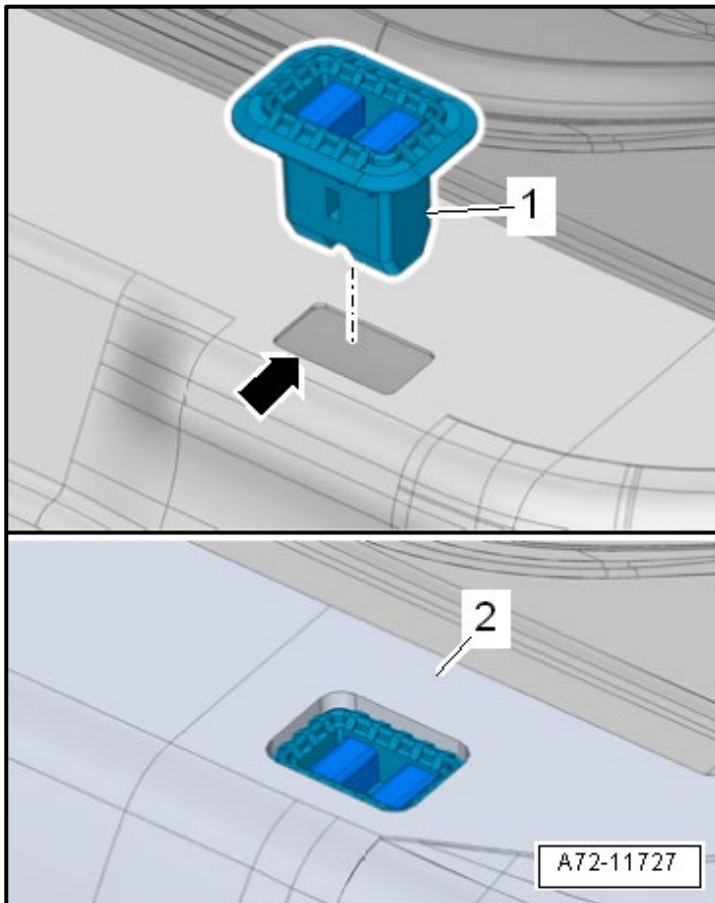

- Replace rear seat bench grommets <1>.

Part Number	Part Description
5GM-886-373	GROMMET

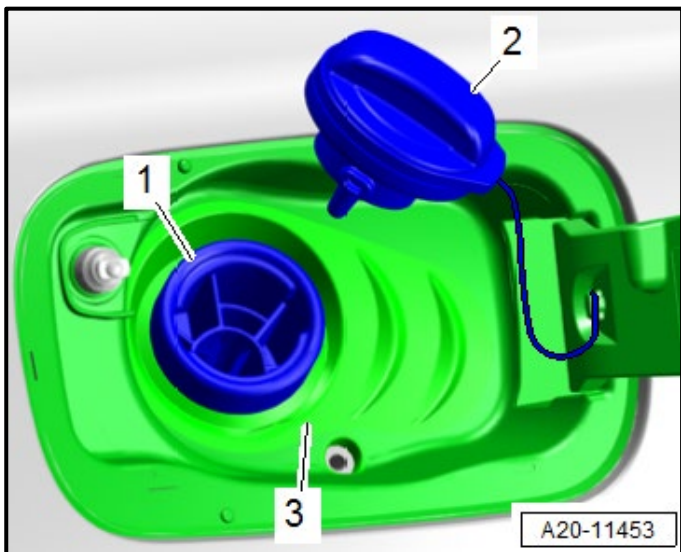

- Open the fuel door and remove the fuel cap <2>.
- Refill the fuel tank with the same amount of fuel removed prior with the -VAS5190A- Fuel Extraction Unit.
- Verify using the sightglass on the side of the -VAS5190A- Fuel Extraction Unit that the fuel tank was filled with the same amount of fuel that was extracted before reconnecting the battery.

NOTE

Risk for repeat repair!

Failing to fill the fuel tank with the same amount of fuel that was extracted can result in fuel level sending unit faults, or fuel gauge inaccuracies. Additional diagnostic time required to perform a capacitive discharge or remove fused power to the instrument cluster to clear these faults or inaccuracies are NOT covered under this campaign.

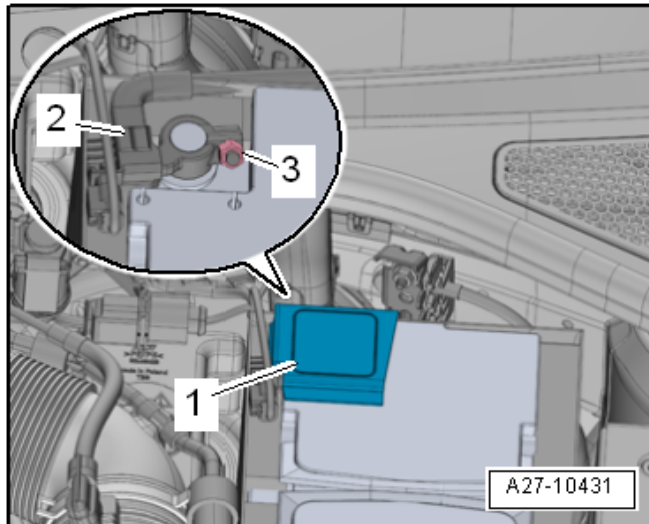

- Reconnect the negative battery terminal <2> to the negative battery post and tighten the nut <3> to 6 Nm.
- Activate the convenience open/close functions.

! NOTE

- After connecting the battery and switching on the ignition, the ASR/ESP Control Lamp -K155- and Electromechanical Power Steering Indicator Lamp light up continuously. The indicator lamps switch off automatically after driving a short distance (less than 100 meters). This activates Steering Angle Sensor -G85-.
- Once -G85- is activated and the ignition is cycled, the Start/Stop function (if equipped) will also start working again and any faults related to the battery being disconnected should be able to be cleared.

Proceed to section C

Section C – Campaign Completion Label

Install Campaign Completion Label

- Fill out and affix Campaign Completion Label, part number CAMP 010 000, next to the vehicle emission control information label.



TIP

Ensure Campaign Completion Label does not cover any existing label(s).

Proceed to Section D

Section D - Parts Return/Disposal

Properly store (retain), destroy or dispose of removed parts in accordance with all state/province and local requirements, unless otherwise indicated and/or requested through the Warranty Parts Portal (WPP) for U.S. and the Part Destruction and Core Disposition Report for Canada.