

RECALL 24V103 / 2024-086 INSPECTION INSTRUCTIONS



Make(s): FR3 & GEORGETOWN
Model(s): ALL MODELS
Model Year(s): 2019 - 2024

Concern:
The two mounting ("L") brackets which the LPG tank is bolted to may fracture within the radius bend, and it is possible there is a lack of weld connecting the L Bracket to the chassis.

Repair Code: N/A
Allotted Time: N/A
Inspection Code: RC-026-05-00-004487
Allotted Time: .20 HRS.

Photo(s) Required: YES, SEE BELOW
Prior Authorization Required: NO
Part(s) Kit Number: N/A
Part(s) Return: YES, SEE BELOW

Turn off LP Gas at LPG Tank(s). Place vehicle in (P) Park and engage the Parking Brake. Disconnect the vehicles' battery Positive and Negative, disconnect any House battery(s) Positive and Negative, if equipped with a generator ensure it is off and lastly, ensure the vehicle is disconnected from shore power. Block any tires/wheels to prevent the vehicle from rolling. Failure to do so may result in electrocution, fire or other personal injury, property damage and/or death.

STEP 1: OPEN THE LPG COMPARTMENT;

STEP 2: USE GLASS CLEANER AND A CLOTH, BRUSH, RAG, OR ANYTHING ELSE NEEDED TO REMOVE DUST AND ROAD GRIME FROM THE "L" BRACKETS THAT THE LPG TANK IS BOLTED TO;

STEP 3: TAKE A PHOTO OF EACH BRACKET;

- ENSURE TO CAPTURE THE BRACKET; FIGURE 1
- ENSURE THE FOCUS OF THE PHOTO IS OF THE BEND/RADIUS; FIGURE 1
- THIS SHOULD BE TWO (2) PHOTOS (FRONT BRACKET AND REAR BRACKET);

STEP 4: TAKE A PHOTO OF EACH BRACKET AND ITS WELDS;

- ENSURE TO CAPTURE THE BRACKET AND WELDS; FIGURE 2
- ENSURE THE FOCUS OF THE PHOTO CAPTURES GOOD VISUALS OF THE BRACKET WELDS; FIGURE 2
- THIS SHOULD BE TWO (2) PHOTOS (FRONT BRACKET AND REAR BRACKET);

STEP 5: SCAN THE QR CODE AND UPLOAD THE PHOTOS;

- THE VIN IS REQUIRED FOR SUBMISSION;

STEP 6: SCAN THE QR CODE BELOW;

- CAPTURE FOUR PHOTOS AND SUBMIT TO THE PORTAL;
- ENSURE YOU HAVE THE FORD VIN AVAILABLE;



NOTE: FOREST RIVER AND ITS PARTNER SUPPLIER WILL REVIEW PHOTOS. IF FURTHER ACTION IS NEEDED, YOU WILL BE NOTIFIED.

RECALL 24V103 / 2024-086 INSPECTION INSTRUCTIONS



Make(s): FR3 & GEORGETOWN
Model(s): ALL MODELS
Model Year(s): 2019 - 2024

Concern:
The two mounting ("L") brackets which the LPG tank is bolted to may fracture within the radius bend, and it is possible there is a lack of weld connecting the L Bracket to the chassis.

Repair Code: N/A
Allotted Time: N/A
Inspection Code: RC-026-05-00-004487
Allotted Time: .20 HRS.

Photo(s) Required: YES, SEE BELOW
Prior Authorization Required: NO
Part(s) Kit Number: N/A
Part(s) Return: YES, SEE BELOW

FIGURE 1 (ONLY SHOWING THE FRONT SIDE)

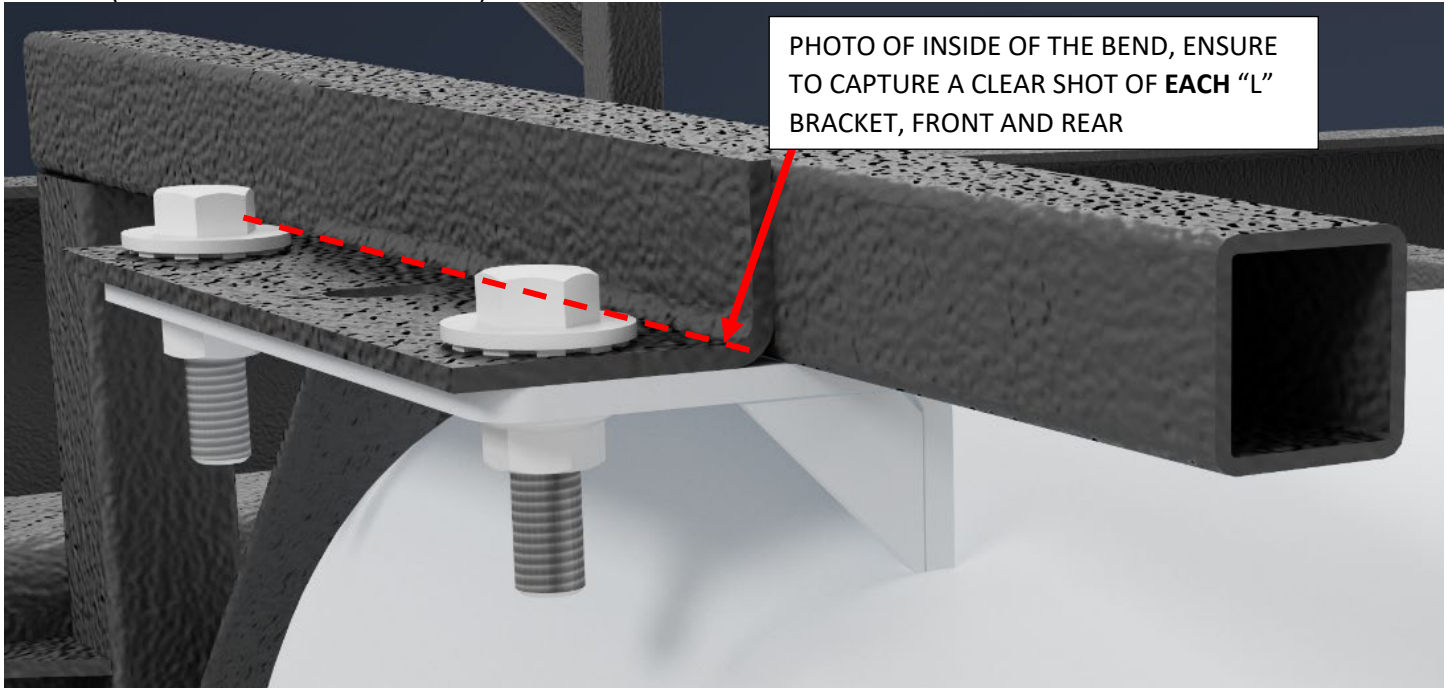

FIGURE 2 (ONLY SHOWING THE FRONT SIDE)

