



## SAFETY RELATED RECALL

Global Recall Action  
Number: H468v5

Changes are highlighted in blue

<b>Subject:</b>  <b>High Voltage (HV) Battery Busbar Fixings</b>	Publication No.: H468v5
	Model: I-PACE (X590)
	Model Year: 2019 - 2024
	Date of Issue: 01 July 2025

<b>To:</b>	All National Sales Companies (NSCs), importers, retailers and authorized repairers.
<b>For the Attention of:</b>	The approved JLR retailer / authorized repairer.
<b>Important:</b>	<p>NOTE: The information in this campaign is intended for use by professional technicians. If you are not a JLR retailer / authorized repairer, do not assume that a condition described affects a specific vehicle. Contact an authorized JLR retailer / authorized repairer to determine if this campaign applies to a specific vehicle.</p> <p>This bulletin has been re-published to update the model years affected.</p>

### FOR THE ATTENTION OF ALL:

#### DESCRIPTION OF ISSUE AND THE EFFECT ON VEHICLE OPERATION

A concern has been identified on a small number of 2019 model year to 2024 model year I-PACE vehicles where the fasteners for the **High Voltage (HV)** battery module to module electrical connecting busbars may not be sufficiently secure, which under some circumstances could result in arcing at the busbar to module connection point. Arcing will generate heat which may lead to a thermal overload condition.

A vehicle thermal overload condition such as fire or smoke can result in an increased risk of occupant injury and / or injury to persons outside the vehicle, as well as property damage.

#### ACTION TO BE TAKEN

JLR has taken the decision to recall affected vehicles to repair the vehicle.

Following procedures appropriate to your market and as required by local legislation, owners of affected vehicles should be contacted requesting that the owner contact their nearest JLR retailer / authorized repairer as soon as possible to arrange for the repair to be completed. The National Sales Company (NSC), Importer, Regional Office or Government agency will contact the customers. If you have any questions about this process, contact your NSC / Importer or Regional Office for more information.

Check the JLR Warranty Portal to make sure affected vehicles are correctly identified prior to starting this campaign. The Warranty Portal will be updated to reflect only those vehicles affected.

JLR retailers / authorized repairers are reminded that they must not sell vehicles identified as affected by this campaign until such time as the repair has been successfully completed.

An owner may indicate that a repair has already been completed for this concern, in which case the full cost of the repair should be reimbursed. Refer to the warranty section of this campaign for details of the Customer Reimbursement and Related Damage Process. At the time of confirming a booking for a vehicle repair, make sure you check the Warranty Portal to confirm if there are any other outstanding campaigns, to make sure the correct parts are available and adequate workshop time is allocated for repairs to be completed in one visit.

For information purposes, a Technical Question and Answer document is attached.

**FOR THE ATTENTION OF NORTH AMERICAN TERRITORIES ONLY:**

National Highway Traffic Safety Administration (NHTSA) reference number: 24V-086

Visit the British Brands Sales Suite (BBSS) website for a list of affected vehicles at your JLR retailer / authorized repairer. Unsold vehicles must be repaired prior to handover of the vehicle for retail sale.

**REGULATORY INFORMATION**

Jaguar Land Rover North America, LLC have informed the National Highway Traffic Safety Administration (NHTSA) of their intent to perform a Safety Recall on certain 2019 model year to 2020 model year Jaguar I-PACE vehicles imported into the United States markets. Information relating to this Safety Recall will be posted on the NHTSA website. United States Federal regulations require that JLR retailers / authorized repairers must be notified within a reasonable time after the manufacturer decides that a defect that relates to motor vehicle safety or a non-compliance exists. United States Federal Law requires JLR retailers / authorized repairers to complete any outstanding Safety Recall before a new vehicle is delivered to the buyer or lessee. Violation of this requirement by a JLR retailer / authorized repairer, in the USA only, could result in a maximum civil penalty of up to the equivalent of \$27,168.00 USD per violation and the equivalent of \$135,828,178.00 USD for a related series of violations. This Safety Recall serves as notification to all JLR retailers / authorized repairers in the United States and Federalized Territories that any affected new vehicles may not be sold and delivered for customer use until the Safety Recall repair is completed.

Jaguar Land Rover North America, LLC recommends that affected sales demonstrator and loaner vehicles are repaired before use, and that used vehicles are repaired before sale. JLR retailers / authorized repairers who choose to proceed against this recommendation, where legally permitted, must clearly and conspicuously disclose the open Safety Recall notice to the applicable customers.

Yours faithfully

Steve Oldham

Global Customer Care Quality Director

# SERVICE INSTRUCTION - H468V5

Changes are highlighted in blue

## Parts Information

### NOTE:

The parts below are for the completion of the Service Inspection only. All other parts that are renewed as a result of the [Technical Assistance \(TA\)](#) must be claimed as related damage through the related damage process.

The parts below should be ordered through JLR in the normal manner.

Description	Part Number	Qty
Busbar bolt	T4K8734	75
<a href="#">Battery Electrical Module (BEM)</a> seal	T4K8513	1
<a href="#">BEM</a> bolt	T4K8733	6
<a href="#">BEM</a> inspection lid seal	T4K8515	1
<a href="#">BEM</a> inspection lid screws	T4K8504	10
<a href="#">BEM</a> to battery lid seal	T4K8516	1
Master service plate to battery lid seal	T4K8519	1
Gasket	T4K8151	8
Gasket	T4K8152	12
Battery lid bolt M5 x 12mm	T4K13071	98
Screw M8 x 20mm	T4K8724	8
<a href="#">Cell Supervisory Circuit (CSC)</a> bracket screw M5 x 8mm	T4K8728	2
Nut M6	T4K8739	2

## SROs

### NOTE:

The SRO time provided is for the completion of the Service Inspection up to raising the [JA](#) and then the re-installation of the components removed up to that point. All repairs completed by the guidance of [JA](#) must be claimed as related damage through the related damage process.

Description	SRO	Time
<a href="#">High Voltage (HV)</a> battery busbar - Inspection	99.03.26	15.5

Description	SRO	Time
Drive in / drive out	10.10.10	0.2

**NOTE:**

Repair procedures are under constant review, and therefore times are subject to change; those quoted here must be taken as guidance only. Always refer to TOPIx to obtain the latest repair time.

**Warranty Information**

Warranty claims should be submitted quoting program code H468 with the relevant option code from the table below. As option codes are used there is no requirement for you to enter SROs or parts, these are included for information only.

Program Code	Option	Description	SRO	Time	Part Number	Qty
H468	A	<a href="#">HV</a> battery busbar - Inspection	99.03.26	15.5	T4K8734	75
					T4K8513	1
					T4K8733	6
					T4K8515	1
					T4K8504	10
					T4K8516	1
					T4K8519	1
					T4K8151	8
					T4K8152	12
					T4K13071	98
					T4K8724	8
					T4K8728	2
					T4K8739	2
					H468	B
T4K8513	1					
T4K8733	6					
T4K8515	1					
T4K8504	10					
T4K8516	1					
T4K8519	1					
T4K8151	8					
T4K8152	12					
T4K13071	98					
T4K8724	8					
T4K8728	2					
T4K8739	2					

**NOTE:**

The option that contains the drive in / drive out allowance may only be claimed when the vehicle has been brought back into the workshop for this action alone to be undertaken.

Warranty claims should be submitted in accordance with the current JLR Global Warranty Manual, and its amendments, unless stated otherwise in this campaign.

**Customer Reimbursement and Related Damage Process****NOTE:**

If there is a requirement to claim for related / consequential damage or customer reimbursement, refer to the related instruction that can be found in TOPIx (in the Search box, search for 'Related Damage Claim' and open the related bulletin link).

# SERVICE INSPECTION

## WARNINGS:

- This procedure must be completed in the exact sequence shown. Failure to do so could result in serious personal injury.
- It is the responsibility of the [Electric Vehicle Senior Authorized Person \(EVSAP\)](#) to make sure they comply with any local legislation regarding working with High Voltage [HV](#) within this procedure.
- This procedure requires the use Class 1 [Personal Protective Equipment \(PPE\)](#), all persons involved in this procedure must have read and understood the [PPE](#) requirements as detailed in section 414-01B Electric Vehicle Safety Rules.
- The approved [PPE](#) must be worn where indicated by the orange [PPE](#) icons within this procedure, all persons involved in this procedure must have read and understood section 100-00 About This Manual before continuing.
- All [PPE](#) equipment must be checked for wear or damage prior to use and replaced if required.
- All safety locking device keys must be kept in the designated key lock box at least 5 meters away from the vehicle.

## NOTES:

- All [Permit To Work \(PTW\)](#) and [Live Work Certificate \(LWC\)](#) documents must be kept for a minimum of 5 years.
- This procedure contains illustrations showing certain components removed to provide extra clarity.
- This procedure contains some variation in the illustrations depending on the vehicle specification, but the essential information is always correct.



E208432

1.

### WARNING:

JLR [EVSAP](#) trained technicians only.

This procedure involves **live working** on [HV](#) battery components. Only technicians qualified to [EVSAP](#) level or higher are allowed to perform this procedure. It is mandated that all technicians involved with the steps in this procedure **must** have read and understood the [Electric Vehicle \(EV\) Safety Rules](#) (see TOPIx workshop manual section 414-01B: Battery, Mounting and Cables - High Voltage System - Description and Operation - Electric Vehicle Safety Rules).

2. Remove the [HV](#) battery (see TOPIx workshop manual section 414-01B: Battery, Mounting and Cables - High Voltage System - Removal and Installation - Electric Vehicle Battery).

3. Position the [EV](#) safety barrier around the [HV](#) battery at a minimum distance of 1 meter to all points on the [HV](#) battery.

4.

**CAUTION:**

The Hazardous Voltage sign **must** be placed on the safety barrier.

Place the Hazardous Voltage sign on the safety barrier.



E306186

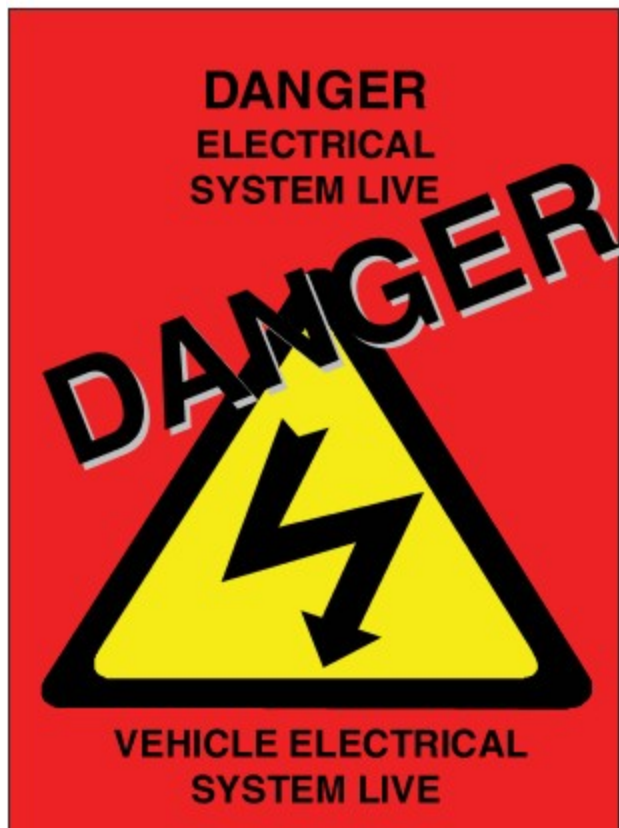

E160529

## SERVICE INSTRUCTION

5.

### CAUTION:

The Danger sign **must** be clearly visible to anyone outside of the live working area.

Place the Danger sign on the [HV](#) battery, the Danger sign **must** be clearly visible to anyone outside of the live work area.

6. The [EVSAP](#) **must** issue a [LWC](#) before any further work can commence (see TOPIx workshop manual section 414-01B: Battery, Mounting and Cables - High Voltage System - Description and Operation - Live Working Certificate).

7. Remove the [BEM](#) baseplate (see TOPIx workshop manual section 414-01B: Battery, Mounting and Cables - High Voltage System - Removal and Installation - Battery Electrical Module Base Plate).



E230327

## SERVICE INSTRUCTION

8.

**WARNING:**

The safety accompanying person **must** sign onto the [LWC](#).

The following steps require the safety accompanying person with the safety hook **outside** the live working area, this person **must** remain in position until instructed otherwise.

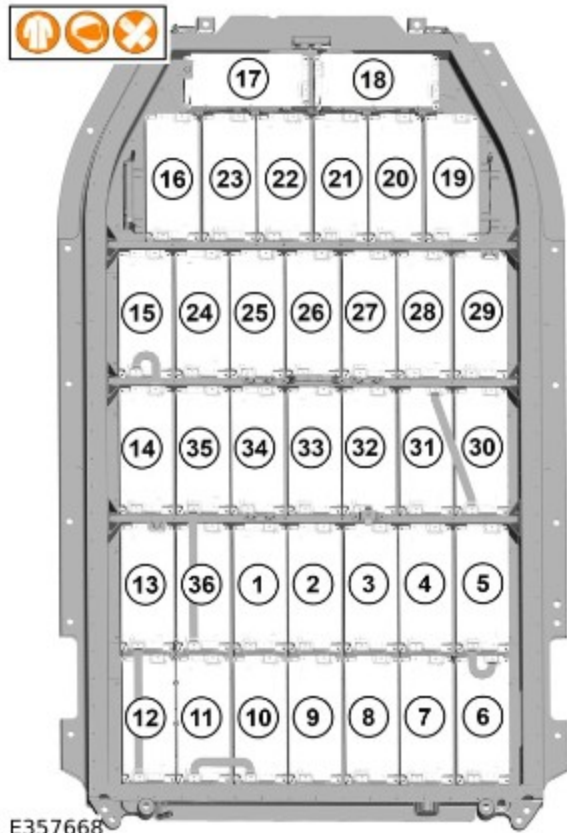

## SERVICE INSTRUCTION

9.

**WARNING:**

Class 1 [PPE](#) **must** now be worn in addition to the Class 0 1000 volt insulated rubber gloves.

**CAUTION:**

Use the illustration to note the installed position of the busbars as they are removed.

The illustration shows the location of the 36 [HV](#) battery modules in the [HV](#) battery.

- When removing the busbars you **must** make a note of their installed positions and provide this information to [TA](#) when reporting your inspection findings.
- Use the illustration as a guide to note the [HV](#) battery modules that each busbar connects between.

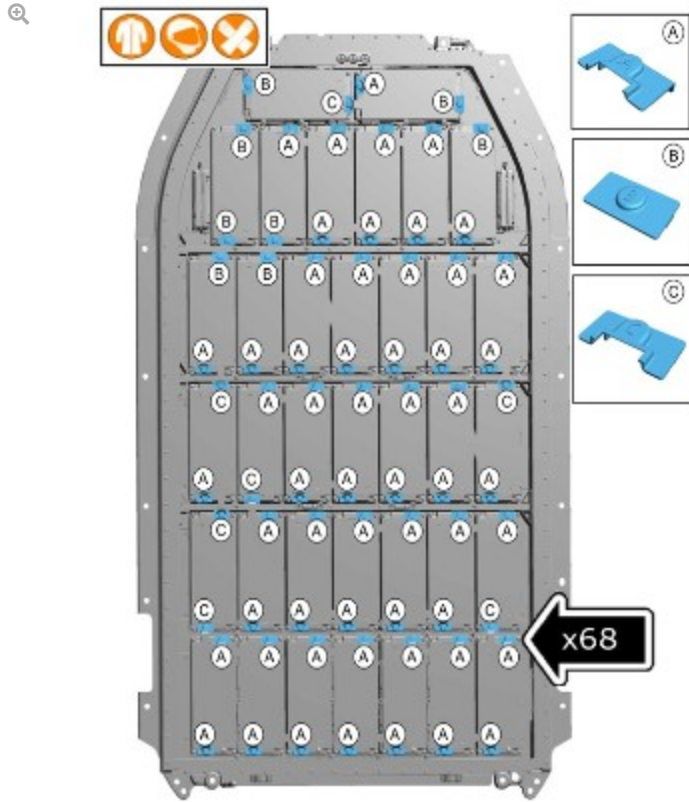

E359038

10.

CAUTIONS:

- Make a note of the installed position of the busbar caps, there are 3 types of caps as shown in the illustration.
- Care **must** be taken not to damage the busbar caps.

Remove the 68 busbar caps.

11. Install pieces 1,2,3,4,5 and 6 of the [HV](#) battery busbar assembly jig JLR-415-081, the busbar cut outs must align with each busbar position.

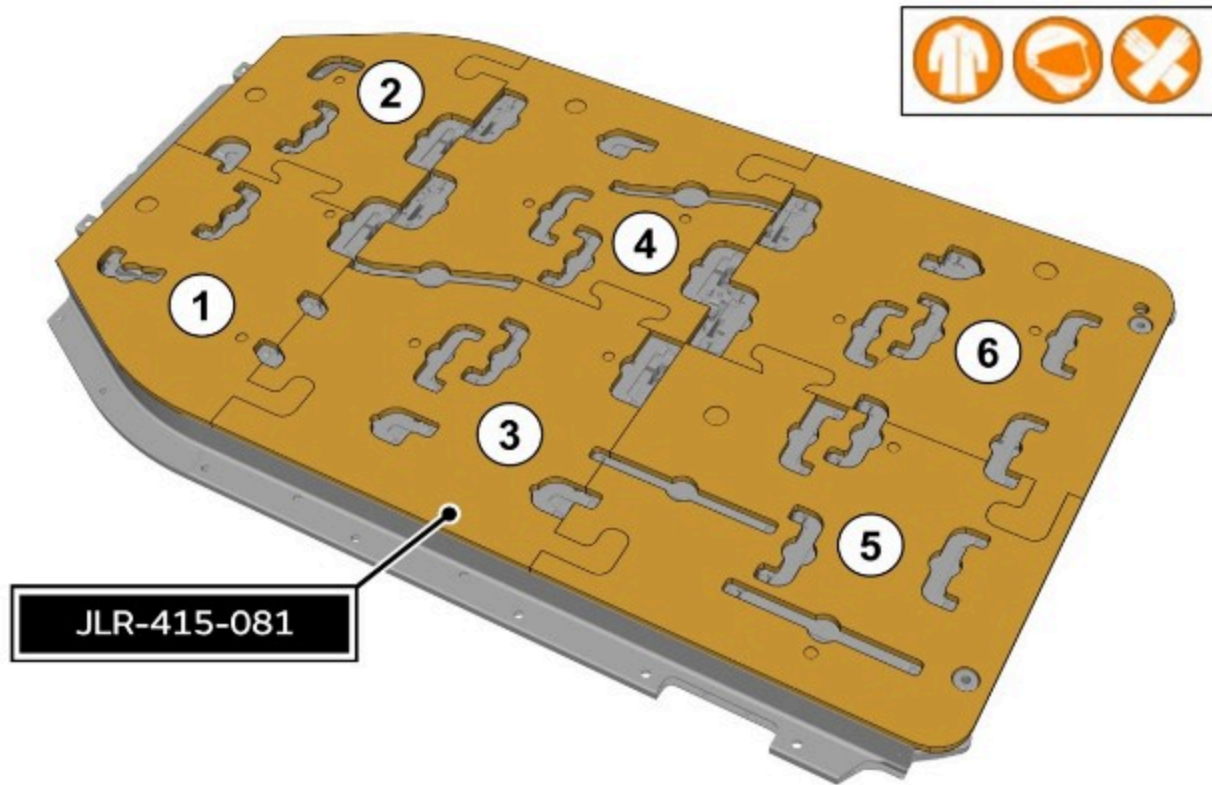

E357225

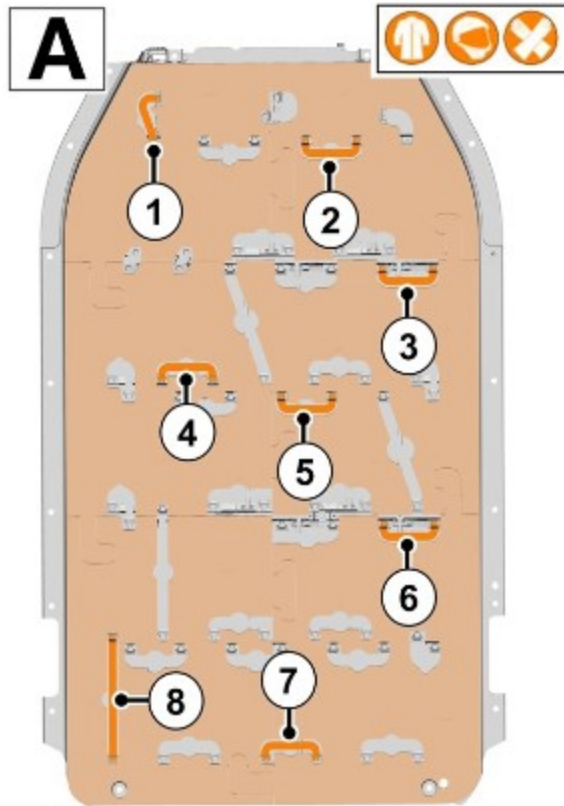

E357226

## SERVICE INSTRUCTION

12.

**WARNINGS:**

- Before removing the busbars make a note of their installed locations and orientations in the [HV](#) battery.
- The busbars **must** be removed in the sequence shown in the illustration marked 'A'.

Remove the 8 busbars in the sequence shown in the illustration marked 'A'. The illustration marked 'B' shows the process to remove each busbar.

- Using the insulated 3/8 drive wrench and insulated T30 torx socket, remove and discard the 2 bolts. Repeat this for all 8 busbars.
- Install the battery module terminal blanking caps, JLR-415-016, to all exposed module terminals.

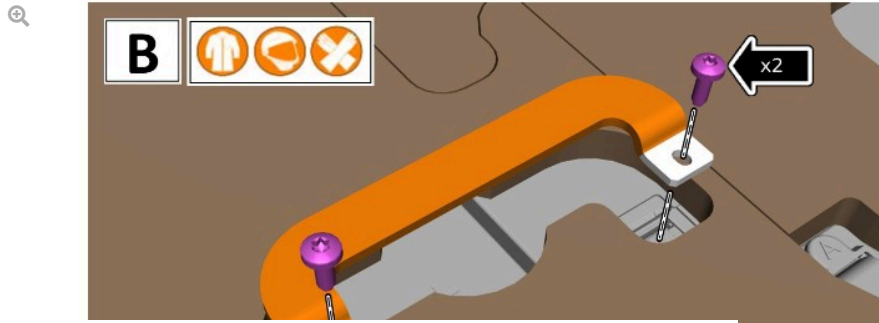

E230327

**WARNING:**  
Class 0 [PPE](#) must still be worn.

When step 12 has been completed Class 1 [PPE](#) can be removed until stated otherwise. Class 0 [PPE](#) must still be worn.

When step 12 has been completed, the safety accompanying person positioned outside the live working area can sign off the [LWC](#) and leave the live working area.

15.

**CAUTIONS:**

- Make a note of all damage found and the installed position of the damaged busbar within the [HV](#) battery.
- All findings **must** be reported to [TA](#).
- The images marked with a **RED 'X'** show an example of busbar damage caused by overheating, make a note of all damage found.

Thoroughly inspect the 8 busbars removed for safe voltage reduction.

- Clean the busbar contact areas (**A**) with alcohol based cleaning fluid and a lint free cloth.
- Visually inspect the contact areas (**A**) for signs of damage.
- Visually inspect the protective insulation for damage (**B**).
- If there **ARE** any signs of damage as shown in the images marked with a **RED 'X'**, make a note of the installed position of the busbar in the [HV](#) battery. **Continue to step 16, do not reinstall the busbars.**
- If there **ARE NOT** any signs of damage, **continue to step 16, do not reinstall the busbars.**

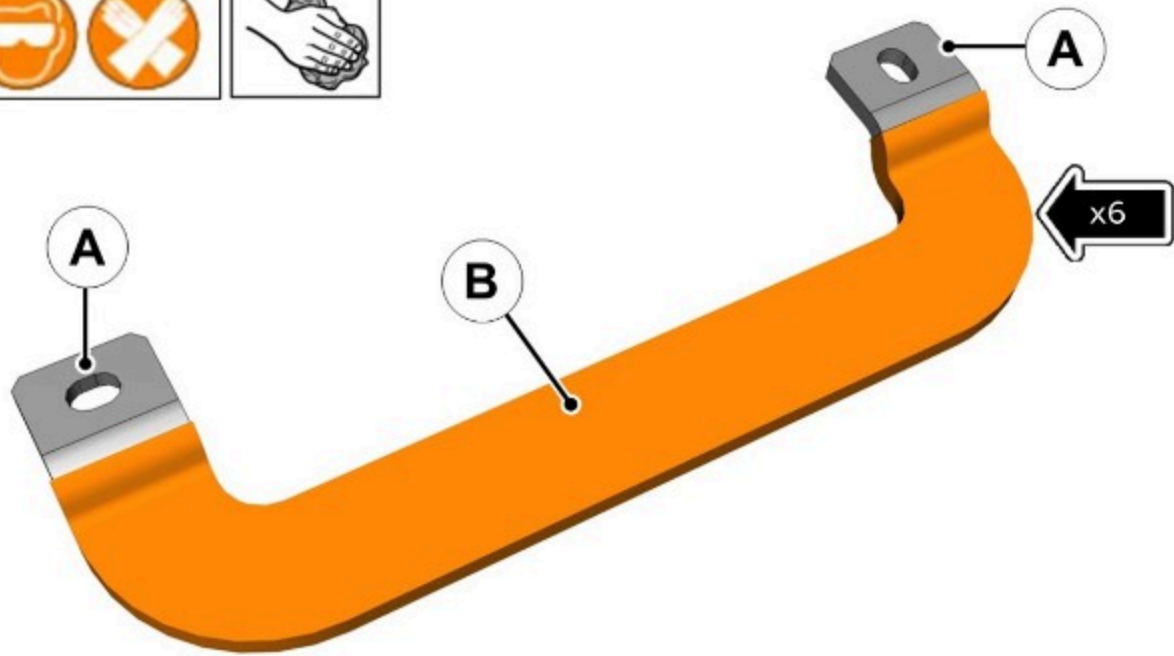

E357235

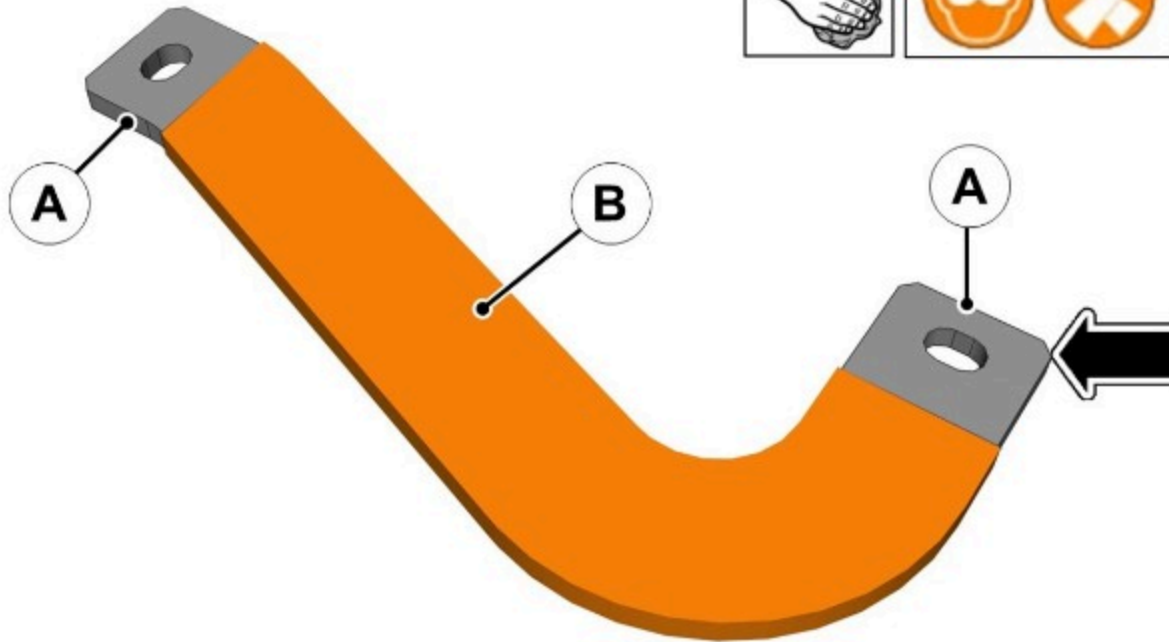

E357234

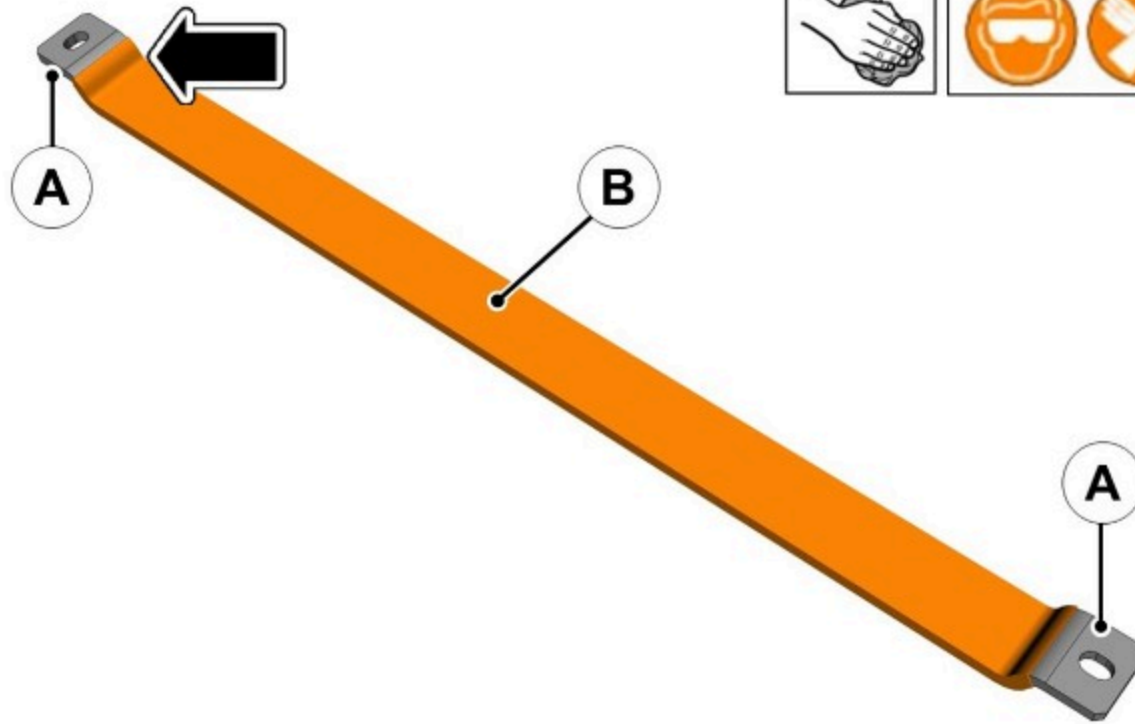

E357233





E357603



E357314

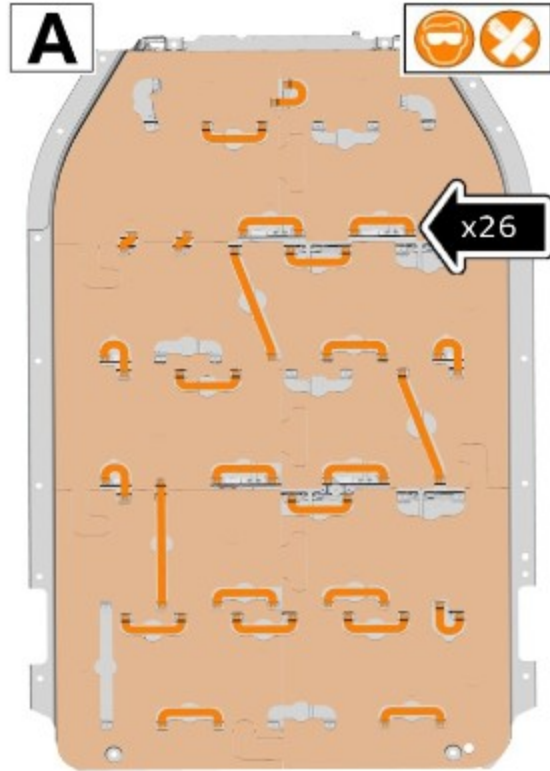

E357343

## SERVICE INSTRUCTION

16.

**WARNING:**

Before removing the busbars make a note of their installed locations and orientations in the [HV](#) battery.

Remove the 26 busbars as shown in the illustration marked 'A'. The illustration marked 'B' shows the process to remove each busbar.

- Using the insulated 3/8 drive wrench and insulated T30 torx socket, remove and discard the 2 bolts. Repeat this for all 26 busbars.
- Install the battery module terminal blanking caps, JLR-415-016, to all exposed module terminals.

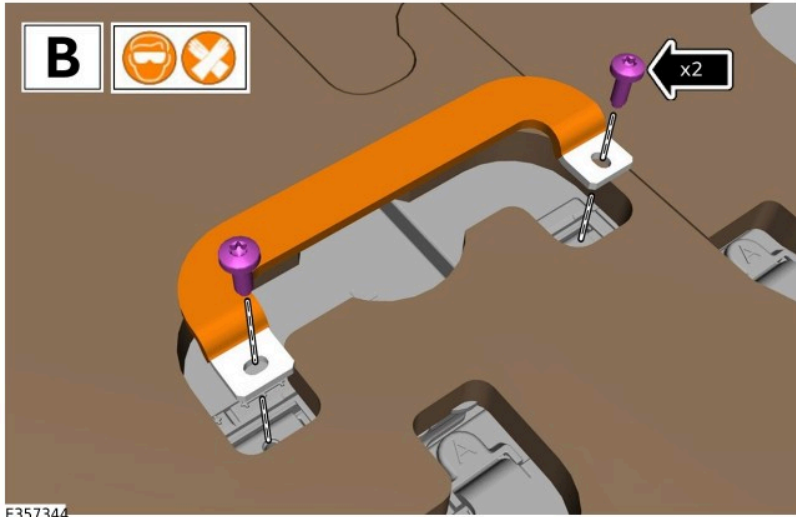

17.

**CAUTIONS:**

- Make a note of all damage found and the installed position of the damaged busbar within the [HV](#) battery.
- All findings **must** be reported to [TA](#).
- The images marked with a **RED 'X'** show an example of busbar damage caused by overheating, make a note of all damage found.

Thoroughly inspect the 26 busbars.

- Clean the busbar contact areas (**A**) with alcohol based cleaning fluid and a lint free cloth.
- Visually inspect the contact areas (**A**) for signs of damage.
- Visually inspect the protective insulation for damage (**B**).
- If there **ARE** any signs of damage as shown in the images marked with a **RED 'X'**, make a note of the installed position of the busbar in the [HV](#) battery. **Continue to step 18, do not reinstall the busbars.**
- If there **ARE NOT** any signs of damage, **continue to step 18, do not reinstall the busbars.**

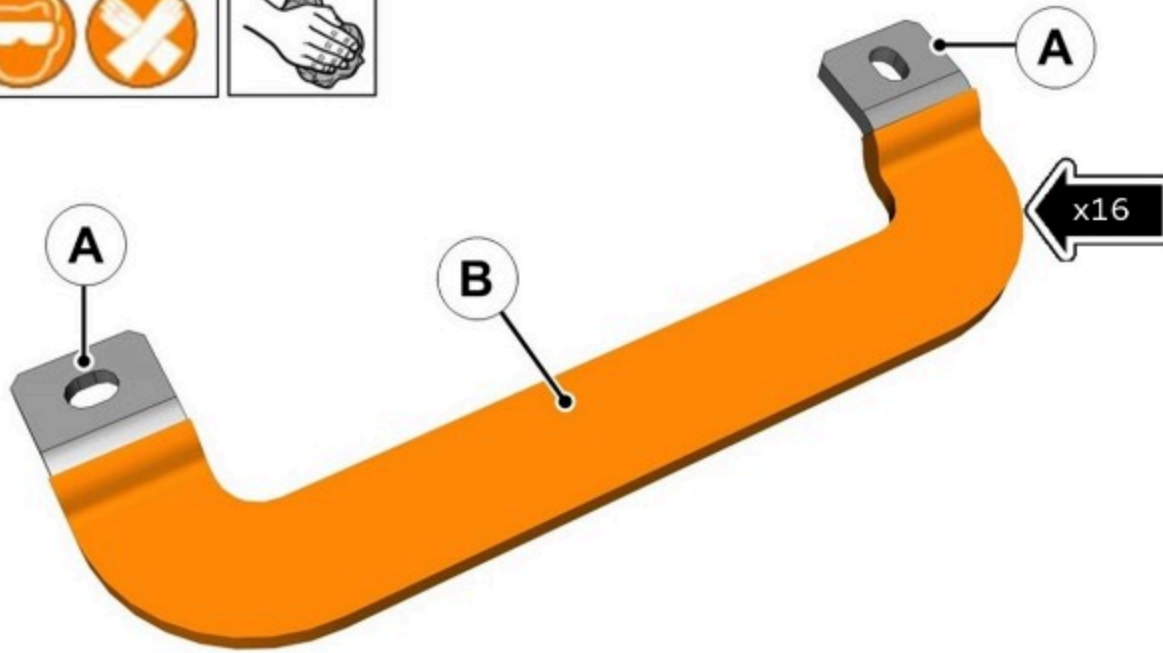

E357345

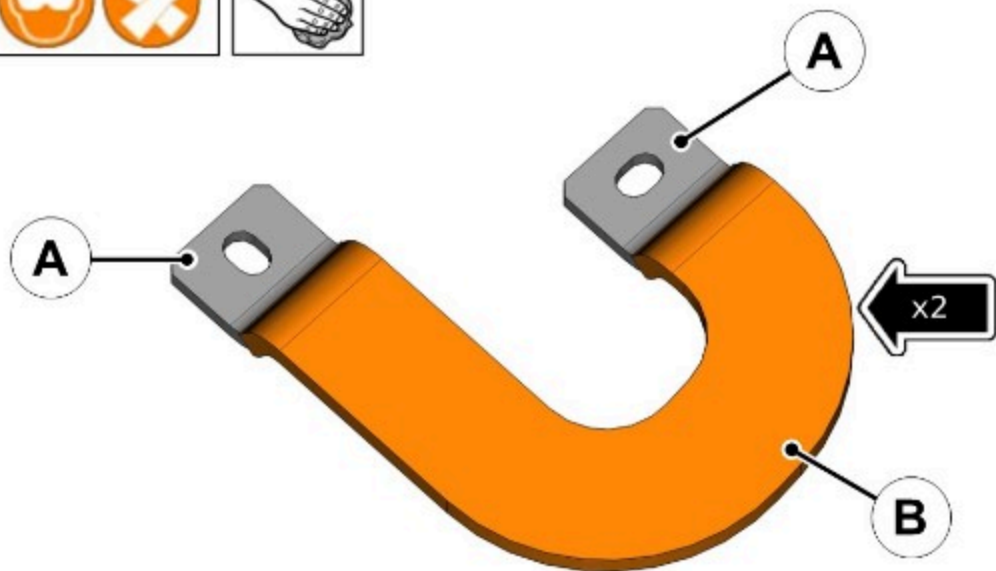

E357347

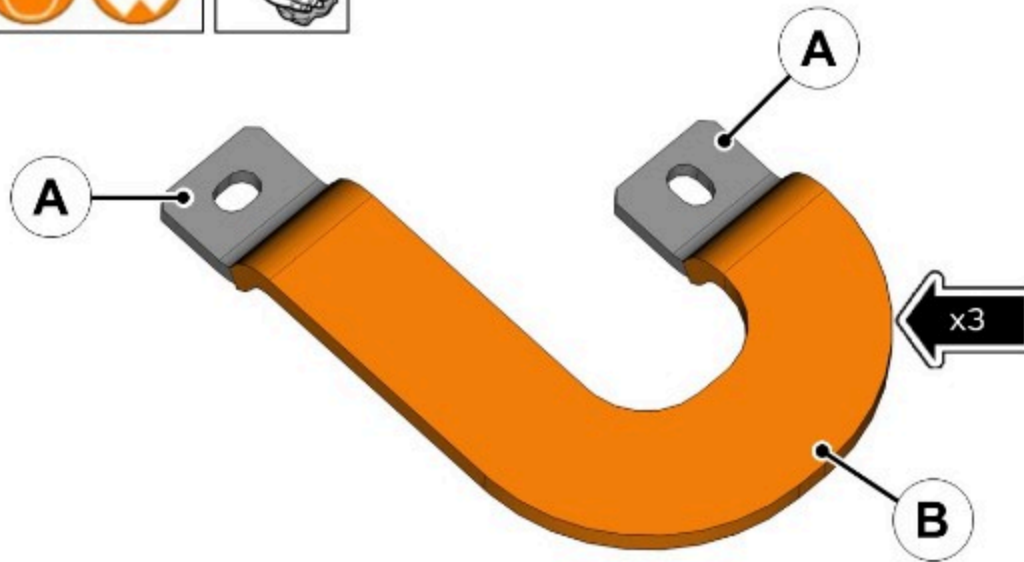

E357350

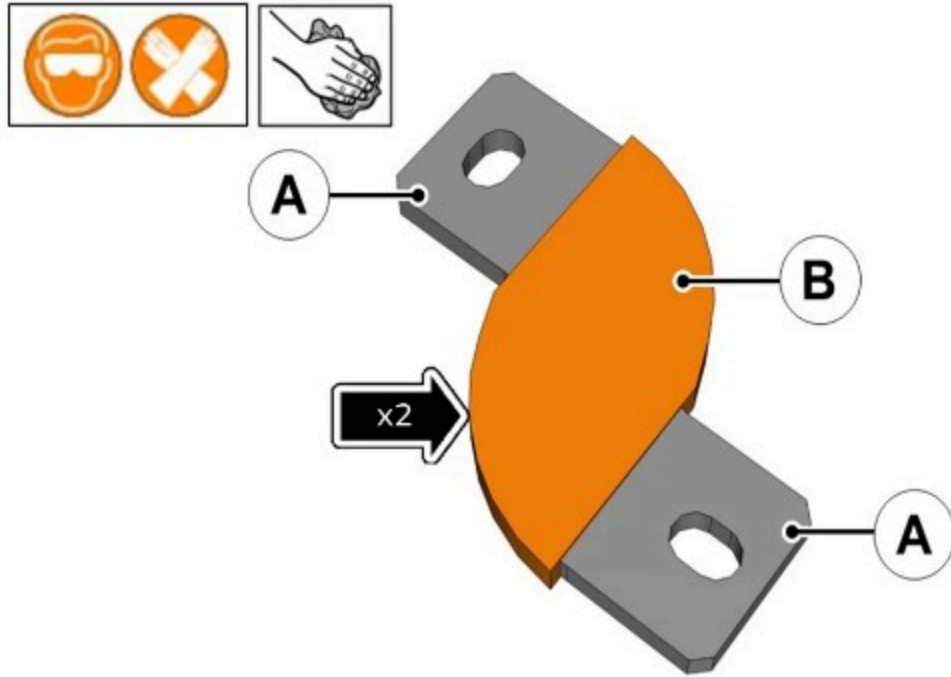

E357348

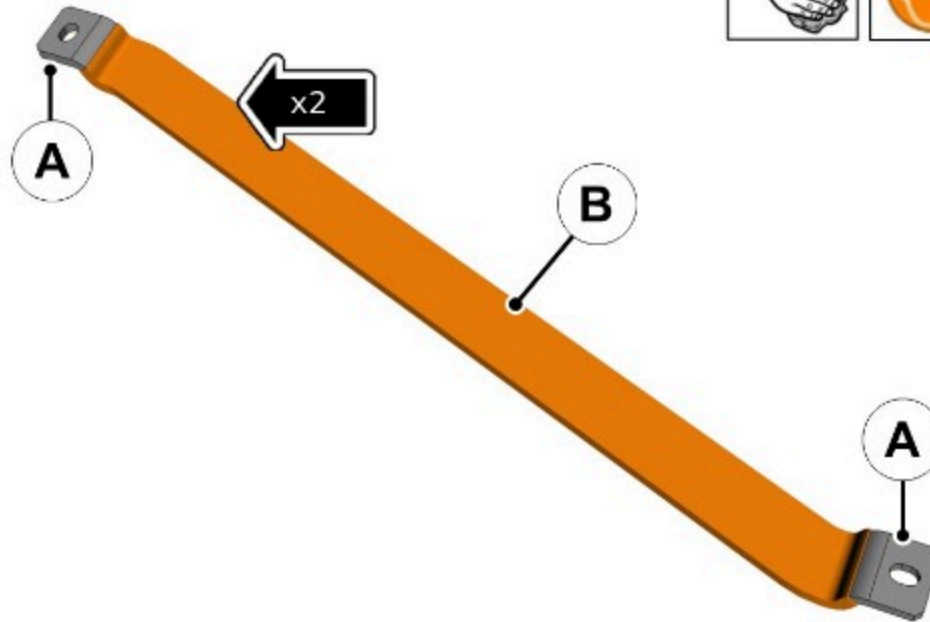

E357349

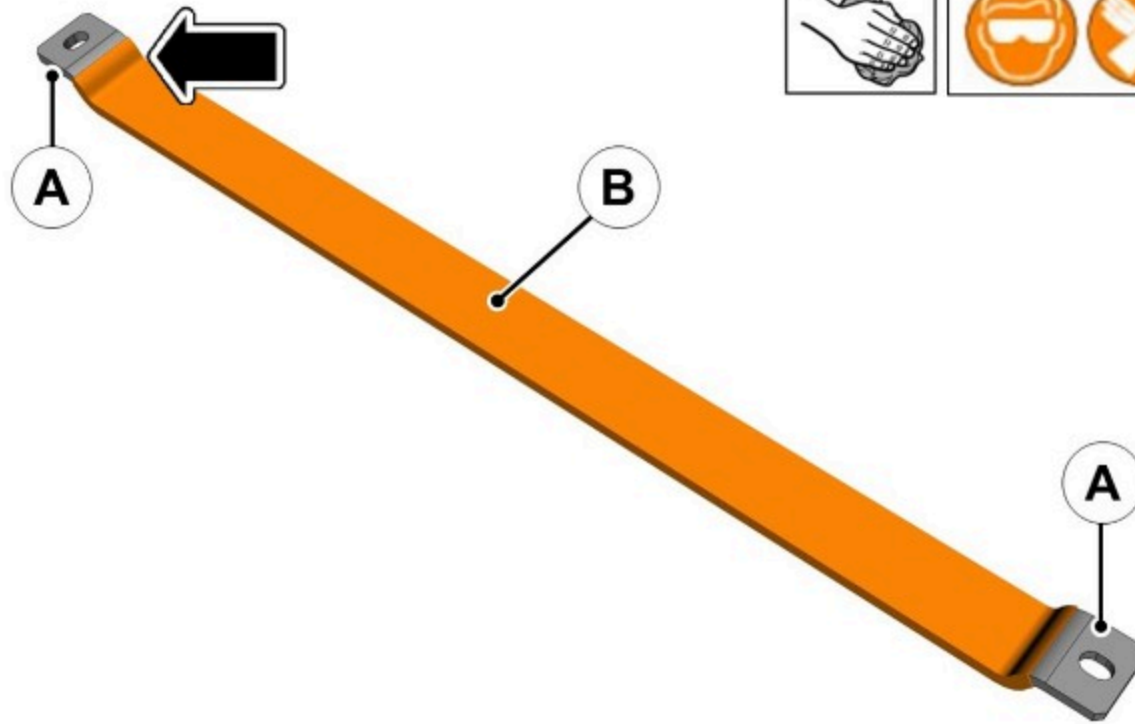

E357233





E357603



E357314

**18.****CAUTIONS:**

- Make a note of all damage found and the installed position of the damaged busbar within the [HV](#) battery.
- All findings **must** be reported to [TA](#).
- The images marked with a **RED 'X'** show an example of busbar damage caused by overheating, make a note of all damage found.

Thoroughly inspect the 4 busbars removed during [BEM](#) baseplate removal.

- Clean the busbar contact areas (**A**) with alcohol based cleaning fluid and a lint free cloth.
- Visually inspect the contact areas (**A**) for signs of damage.
- Visually inspect the protective insulation for damage (**B**).
- If there **ARE** any signs of damage as shown in the images marked with a **RED 'X'**, make a note of the installed position of the busbar in the [HV](#) battery. **Continue to step 19.**
- If there **ARE NOT** any signs of damage, **continue to step 19.**

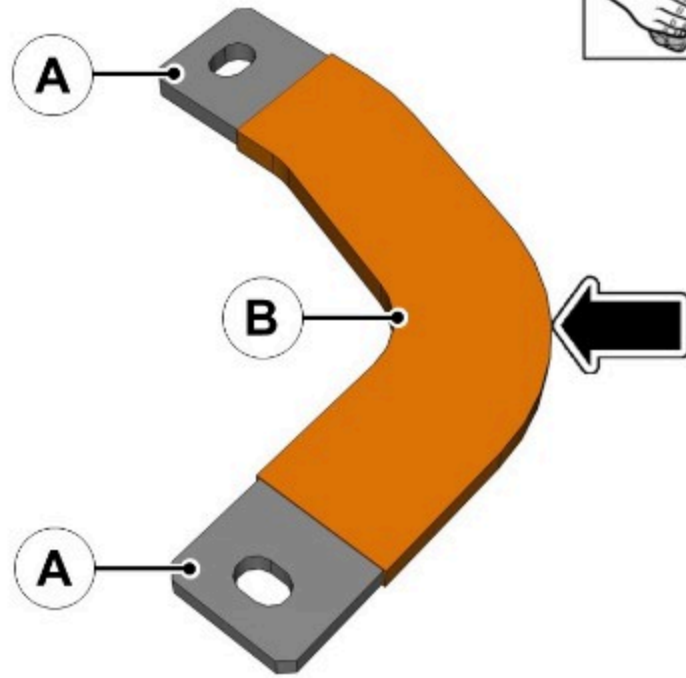

E357478

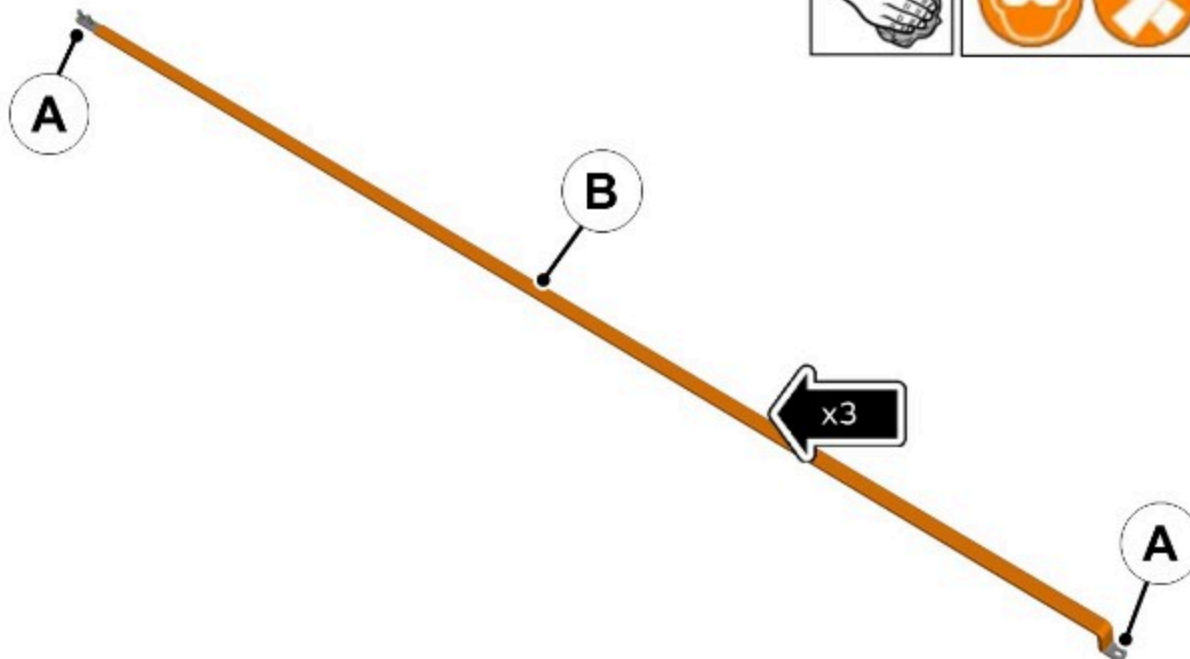

E357479





E357603



E357314

**19.****CAUTIONS:**

- Make a note of all damage found and the installed position of the damaged busbar within the [HV](#) battery.
- All findings **must** be reported to [TA](#).
- The images marked with a **RED 'X'** show an example of busbar damage caused by overheating, make a note of all damage found.

Thoroughly inspect the 5 [BEM](#) baseplate busbars.

- Clean the busbar contact areas (**A**) with alcohol based cleaning fluid and a lint free cloth.
- Visually inspect the contact areas (**A**) for signs of damage.
- Visually inspect the protective insulation for damage (**B**).
- If there **ARE** any signs of damage as shown in the images marked with a **RED 'X'**, make a note of the installed position of the busbar in the [HV](#) battery. **Continue to step 20.**
- If there **ARE NOT** any signs of damage, **continue to step 20.**

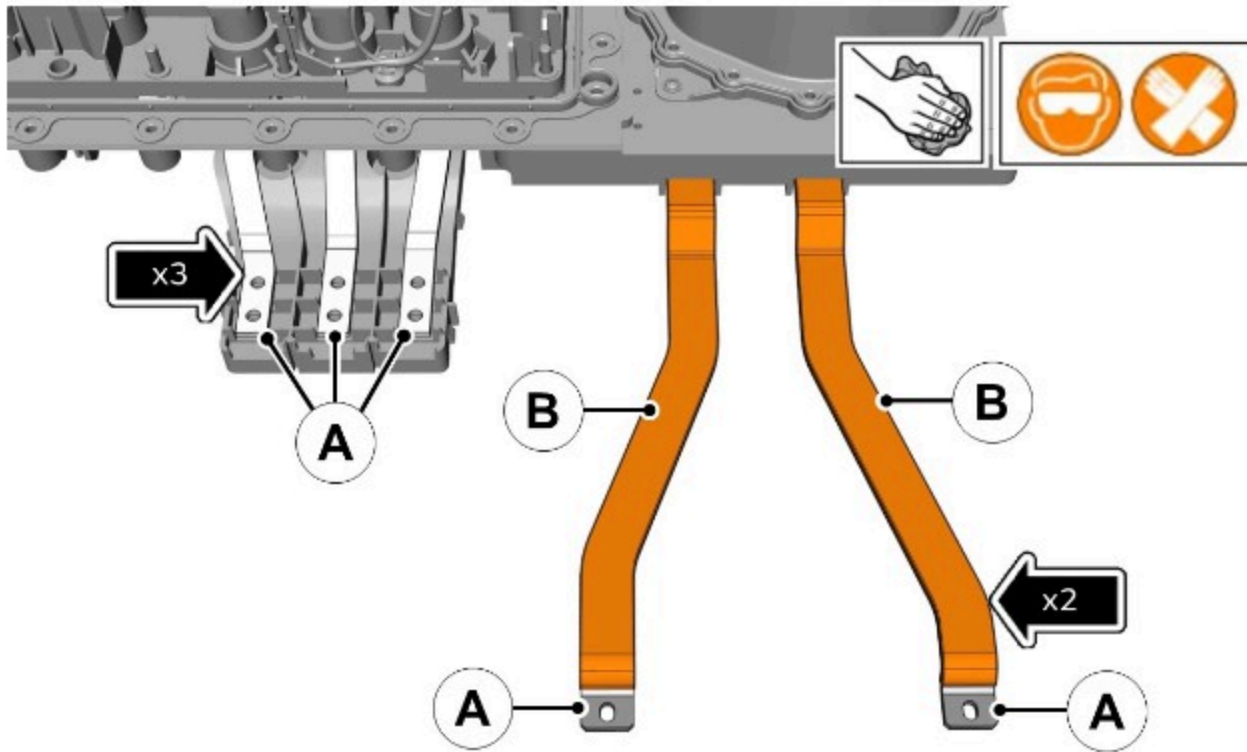

E357482





E357603



E357314

20. Remove the [HV](#) battery busbar assembly jig JLR-415-081.

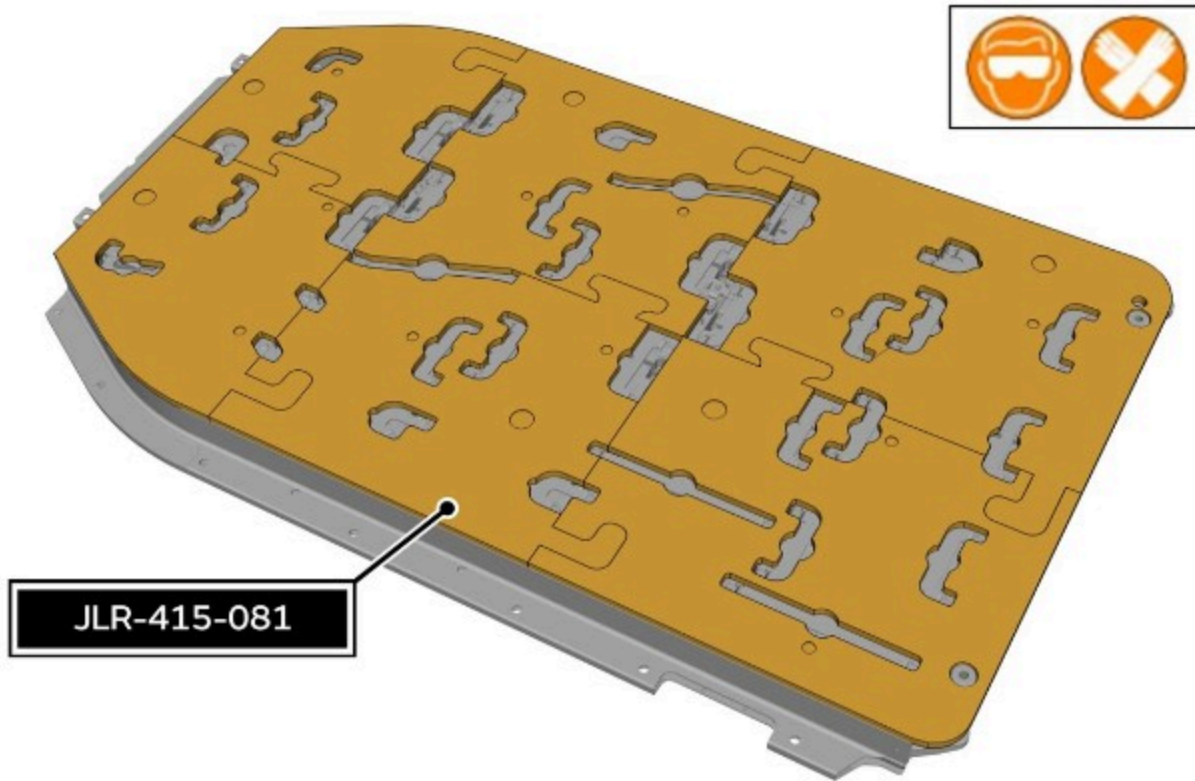

E357486

21.

**CAUTIONS:**

- Make a note of all damage found and the installed position of the damaged busbar within the [HV](#) battery.
- All findings **must** be reported to [TA](#).
- The images marked with a **RED 'X'** show an example of busbar damage caused by overheating, make a note of all damage found.

Thoroughly inspect the 3 [HV](#) connector busbars.

- Clean the busbar contact areas (**A**) with alcohol based cleaning fluid and a lint free cloth.
- Visually inspect the contact areas (**A**) for signs of damage.
- Visually inspect the protective insulation for damage (**B**).
- If there **ARE** any signs of damage as shown in the images marked with a **RED 'X'**, make a note of the installed position of the busbar in the [HV](#) battery. **Continue to step 22.**
- If there **ARE NOT** any signs of damage, **continue to step 22.**

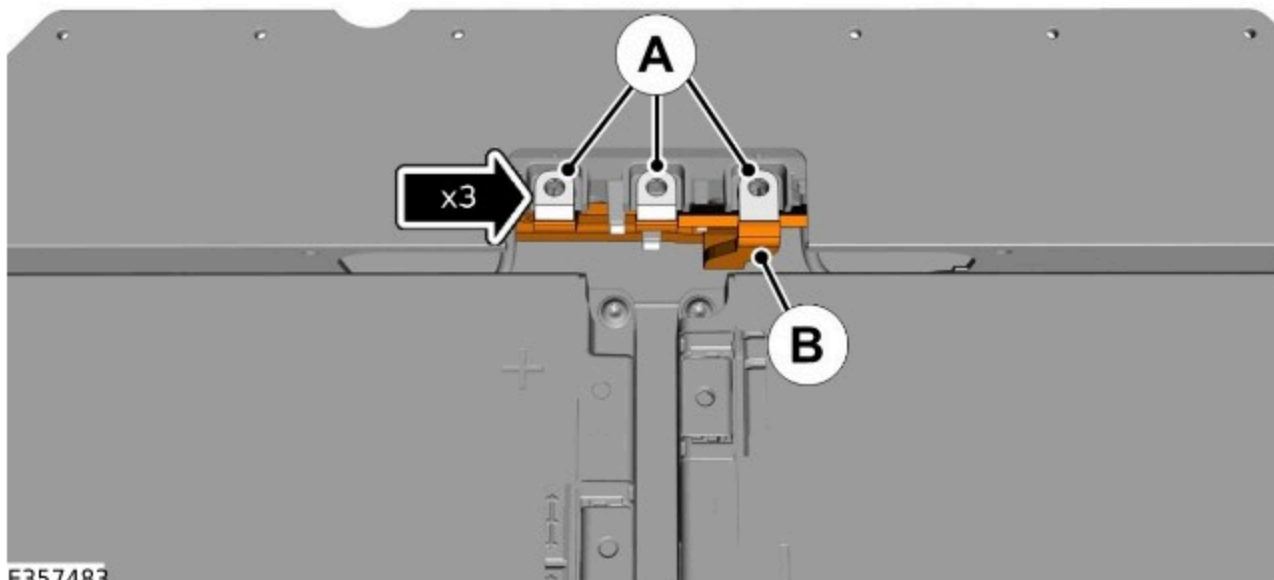

E357483





E357603



E357314

**22.****CAUTIONS:**

- Each [HV](#) battery module has 2 contact areas, all contacts areas **must** be thoroughly inspected.
- All findings **must** be reported to [TA](#).
- The image marked with a **RED 'X'** show an example of [HV](#) battery module damage caused by overheating, make a note of all damage found.

Thoroughly inspect the 36 [HV](#) battery module contact areas.

- Remove the battery module terminal blanking caps, JLR-415-016, from the module terminals.
- Clean the [HV](#) battery module contact areas with alcohol based cleaning fluid and a lint free cloth.
- Visually inspect the [HV](#) battery module contact areas for signs of damage.
- If there **ARE** any signs of damage as shown in the images marked with a **RED 'X'**, make a note of the installed position of the busbar in the [HV](#) battery. **Continue to step 23.**
- If there **ARE NOT** any signs of damage, **continue to step 23.**

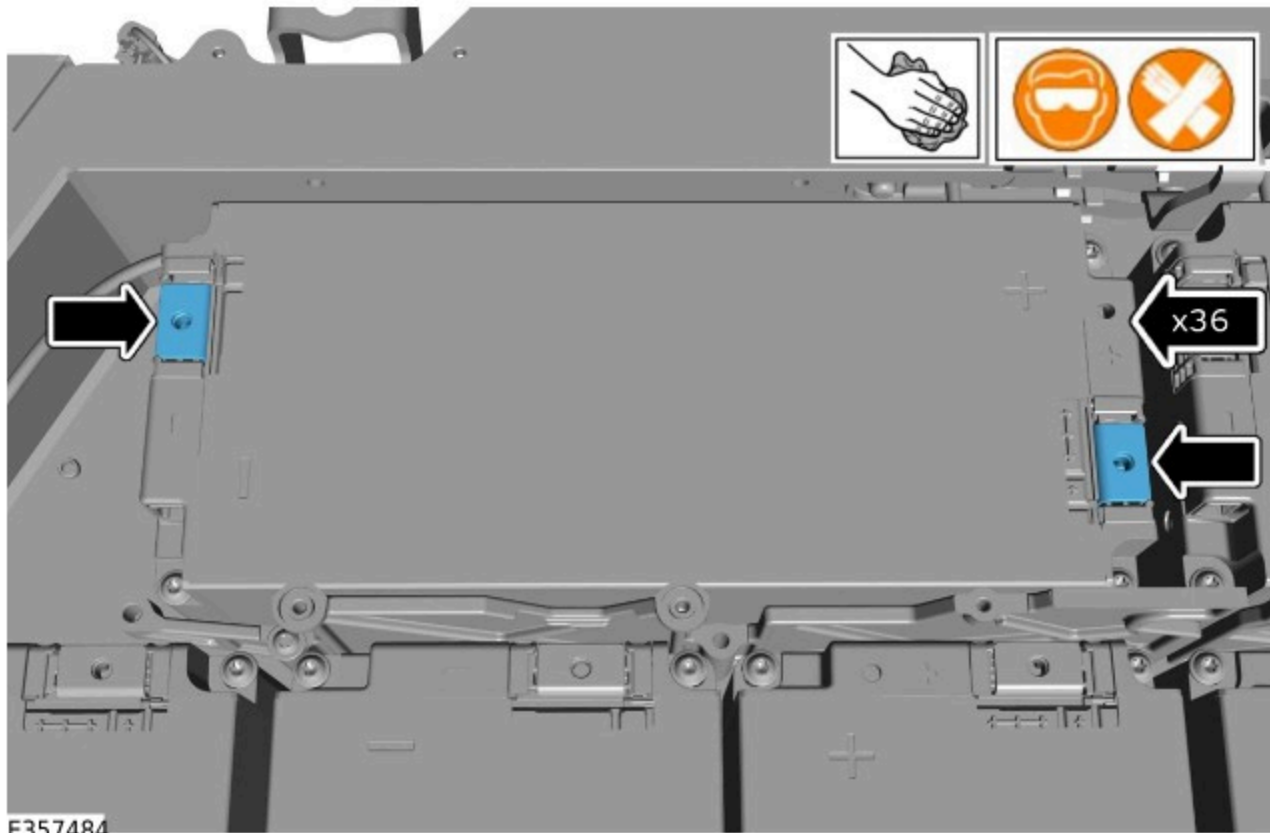

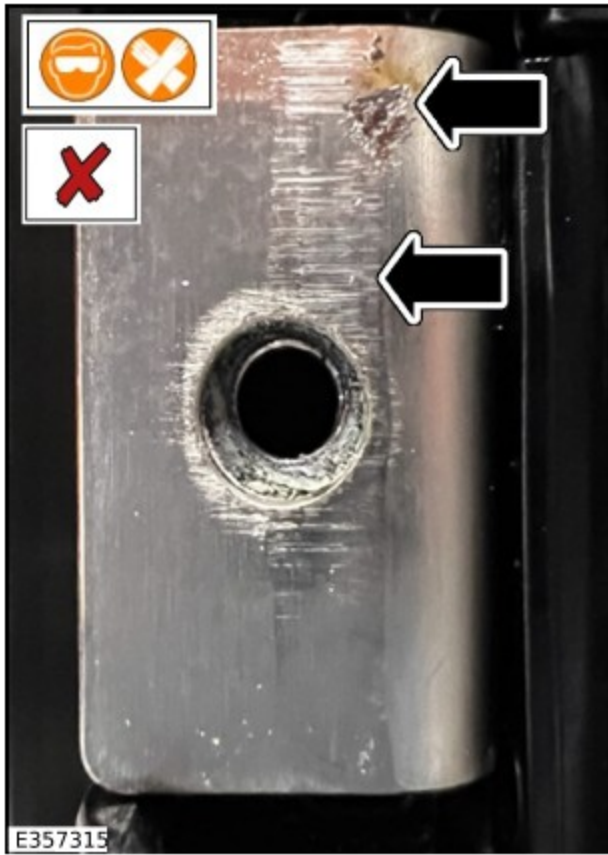

23.

**WARNINGS:**

- Before raising a **TA** you **must** follow steps 23 to 25 to make the live working area safe.
- This step requires the aid of an assisting person to help the **EVSAP** inside the live working area.
- The assisting person **must** be qualified to **Electric Vehicle Competent Person (EVCP)** or higher and be signed onto the **LWC**.

With the aid of an assisting person, install the **HV** battery cover.

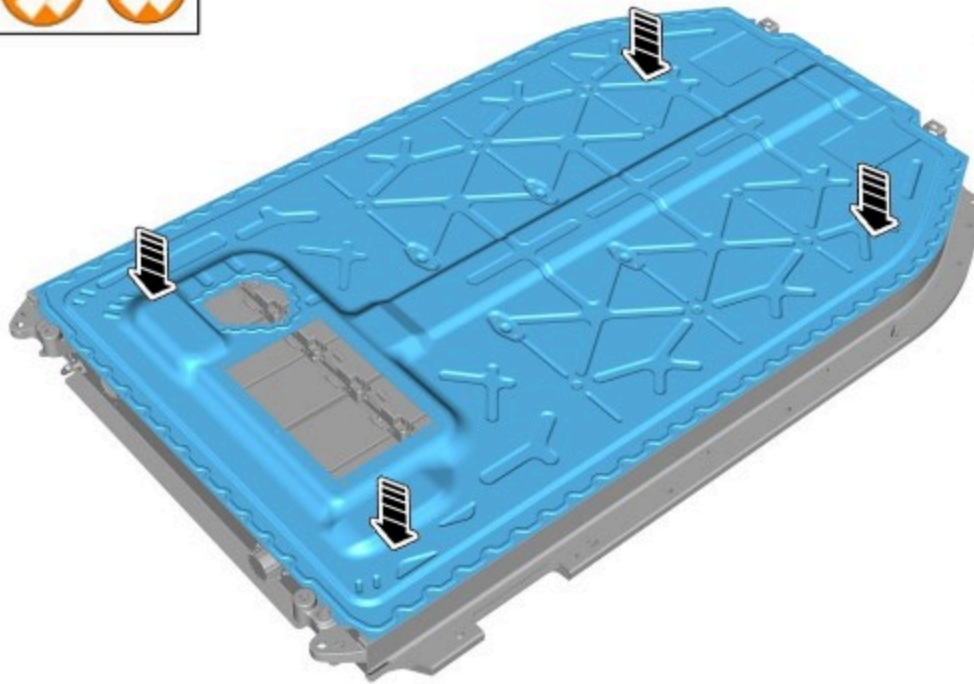

E357488

24. Install the transparent insulated mat JLR-415-015.

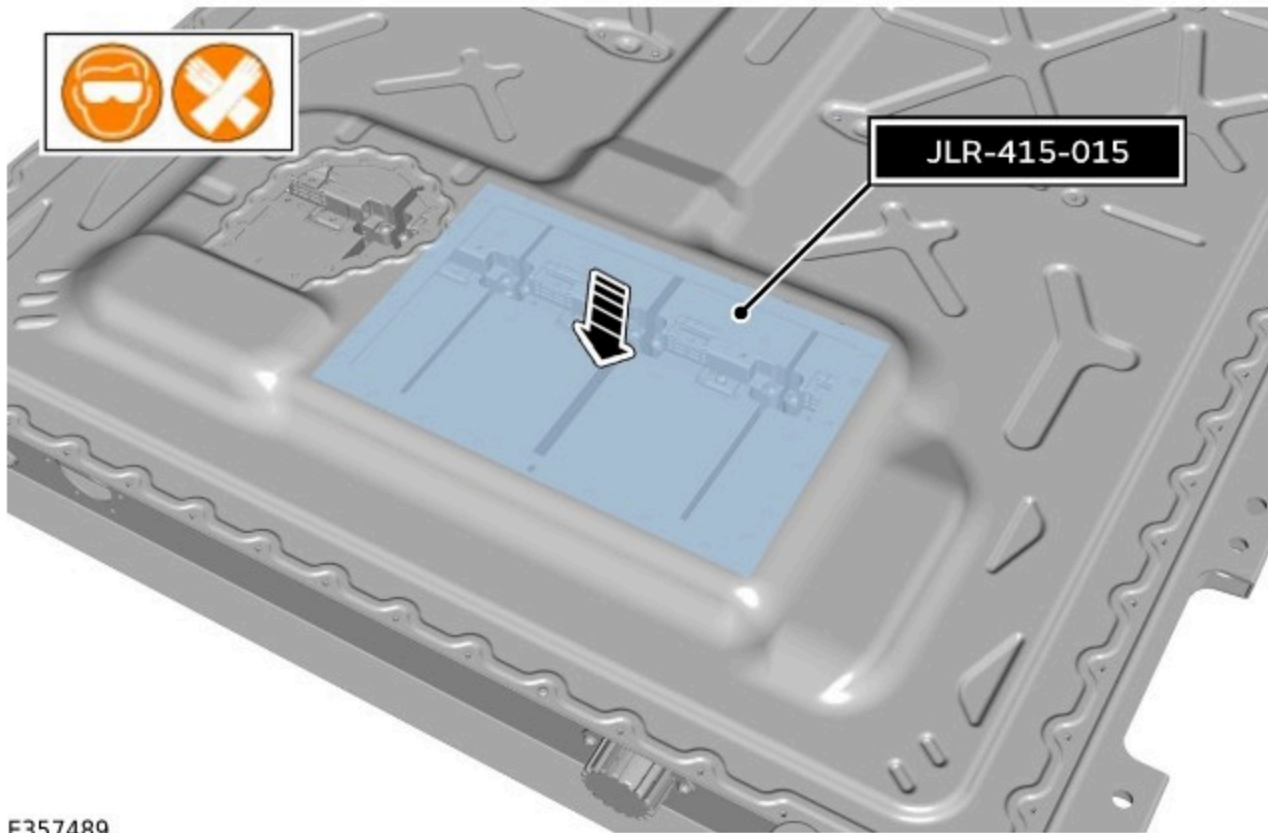

E357489

25. Install and hand tighten 6 bolts as shown in the illustration.

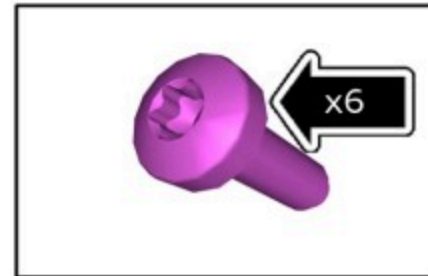
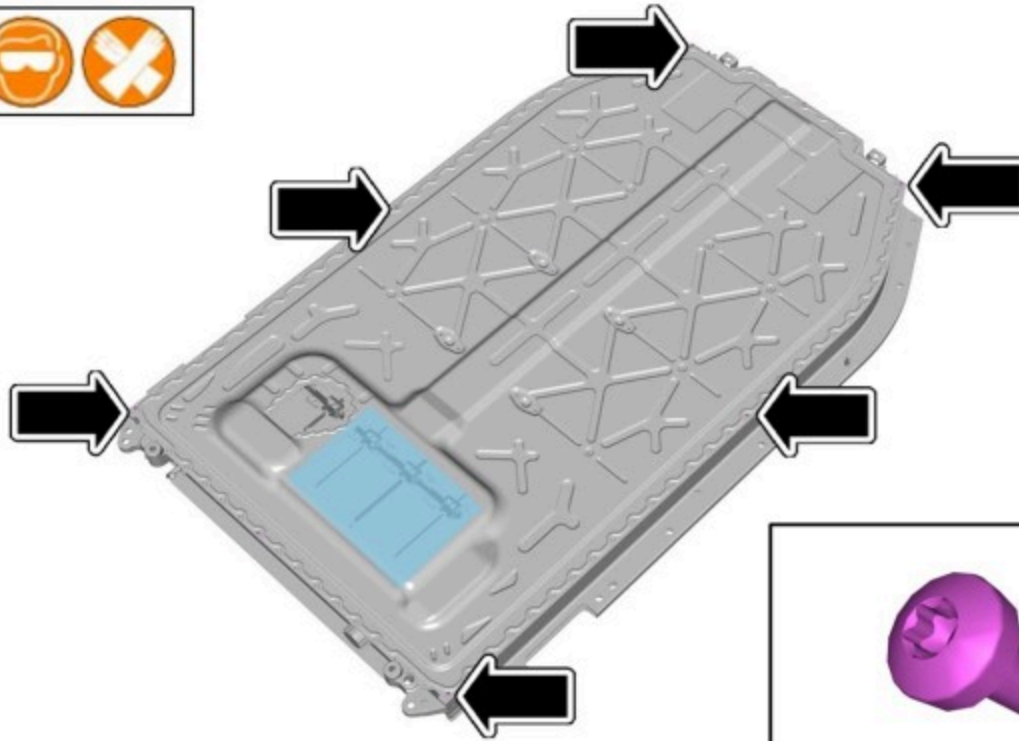

E357604

26.

**CAUTIONS:**

- **All findings must** be reported to [TA](#), this includes if damage is not found.
- Include images of all damage found and the location of the damaged components inside the [HV](#) battery.
- [TA](#) will provide confirmation of the repairs that are required for the [HV](#) battery.
- All additional parts and labour required to complete the repair guided by [TA](#) must be claimed as related damage through the related damage process.

**Following the thorough inspection of all busbars and [HV](#) battery modules, raise a [TA](#) stating the campaign number H468.**

- **Provide evidence of all busbar damage found.**
- **Provide evidence of all [HV](#) battery module contact area damage found.**
- **If no evidence of damage is present on any of the busbar's and [HV](#) modules, photographic evidence of each connection is still required to confirm that no damage is present.**
- **When providing evidence, include the location of each busbar and [HV](#) battery module within the [HV](#) battery.**
- **Await further instruction from [TA](#).**

**SAMPLE CUSTOMER LETTER - FOR INFORMATION ONLY**

Name  
Address line 1  
Address line 2  
Address line 3  
Post Code

Vehicle Identification Number (VIN):  
Registration Number:  
Program Number: H468

Date: month/year

**SAFETY RELATED RECALL - I-PACE - High Voltage (HV) Battery Busbar Fixings**

Dear

JLR would like to advise you that during ongoing quality assessment of our product it has been identified that a possible safety related problem may occur on certain I-PACE vehicles within a specific production range. Read the information below, this will explain the actions that we intend to take and what you will need to do.

**Why are we contacting you?**

A concern has been identified on a small number of 2019 model year to 2024 model year I-PACE vehicles where the fasteners for the [High Voltage \(HV\)](#) battery module to module electrical connecting busbars may not be sufficiently secure, which under some circumstances could result in arcing at the busbar to module connection point. Arcing will generate heat which may lead to a thermal overload condition.

A vehicle thermal overload condition such as fire or smoke can result in an increased risk of occupant injury and / or injury to persons outside the vehicle, as well as property damage.

**What will your JLR retailer/authorized repairer do?**

At your visit, your preferred JLR retailer / authorized repairer will inspect the busbar fixings and install new components, as required.

**How long will it take?**

The work on your vehicle will be completed as quickly and efficiently as possible in order to minimize inconvenience to you. Your JLR retailer / authorized repairer will be able to advise how long your vehicle will be required for when a booking is made.

**What we are asking you to do**

Contact your preferred JLR retailer / authorized repairer without delay. To book your vehicle in for this action you will need to provide the JLR retailer / authorized repairer with the following which are detailed at the beginning of this letter:

- The VIN for your vehicle
- Vehicle registration number of your vehicle.
- The program code for the action.

If you do not have a JLR retailer / authorized repairer, access [www.jaguar.co.uk](http://www.jaguar.co.uk) or [www.jaguar.com](http://www.jaguar.com) for contact details.

If you no longer own the vehicle could you complete the 'Change of Ownership' slip attached to this letter, returning the slip to JLR Limited immediately in the enclosed 'Freepost' envelope. This will enable us to make contact with the new owner.

**If you have concerns**

If you experience any concerns relating to this Recall, contact the Service Manager at the JLR retailer / authorized repairer for assistance or contact the JLR Customer Experience Center on 0345 303 2303 or (enter phone number).

This bulletin is being issued in accordance with the legislative or industry requirements concerning vehicle defects. The authorities will closely monitor the response rate of this bulletin.

Treat this matter with the urgency it requires, JLR Limited apologize for any inconvenience this bulletin may cause and thank you, in advance, for your co-operation.

Yours sincerely

Head of Business

<b>Technical Questions And Answers</b>	
<b>FOR USE ON ENQUIRY</b>	
<b>JLR Recall H468</b>	
<b>I-PACE <a href="#">High Voltage (HV)</a> Battery Loose Busbar Fixings</b>	

A concern has been identified on a small number of 2019 model year to 2024 model year I-PACE vehicles where the fasteners for the [HV](#) battery module to module electrical connecting busbars may not be sufficiently secure, which under some circumstances could result in arcing at the busbar to module connection point. Arcing will generate heat which may lead to a thermal overload condition.

### **Question 1**

Who do I contact if a member of the press contacts me about this recall?

#### **Answer**

Make sure that any press enquiries are referred to the JLR Corporate Affairs office.

### **Question 2**

Why is JLR recalling certain models?

#### **Answer**

JLR is conducting a voluntary safety recall involving certain 2019 model year to 2024 model year Jaguar I-PACE vehicles where data has shown that the busbar fasteners within the high voltage battery may not be sufficiently secure.

### **Question 3**

Can you tell me more about what is wrong with the vehicles?

#### **Answer**

Engineering analysis of the [HV](#) battery pack data received through the [Diagnostic Over The Air \(DOTA\)](#) route has shown that, in a small number of vehicles, there is an abnormal resistance at the busbar fixings within the [HV](#) battery pack. The elevated resistance is due to insecure busbar fixings. Insecure busbar fixings could lead to arcing which could in turn lead to a thermal overload condition. A thermal overload condition such as fire or smoke can result in an increased risk of occupant injury and / or injury to persons outside the vehicle, as well as property damage.

**Question 4**

How would the customer become aware of potentially having this concern?

**Answer**

Vehicles may suffer from a decrease in range, or in some cases owners may notice a burning smell, smoke or fire.

**Question 5**

Does this concern affect vehicle safety?

**Answer**

JLR has determined that the potential for arcing to occur could pose a risk to vehicle safety due to the risk of a fire developing.

**Question 6**

Has JLR received many complaints?

**Answer**

JLR has received a small number of complaints which have been attributed to this issue.

**Question 7**

Have there been any accidents or injuries?

**Answer**

There have been no reports of accidents or injuries relating to this concern of which JLR is aware.

**Question 8**

How was the concern discovered?

**Answer**

The concern was identified through JLR's field reporting process.

**Question 9**

How long has JLR known about this concern?

**Answer**

Investigations relating to unusual battery module resistance readings commenced in late August 2023.

**Question 10**

Is the concern leading you to any concerns regarding the reliability of a system, which is supposed to be designed and engineered for the passengers' safety? What type of measures are you planning to take?

**Answer**

JLR has no concerns with the overall reliability of the vehicle. JLR carefully monitors field data to make sure that any matters relating to safety and compliance are rigorously investigated.

**Question 11**

What has JLR done in production?

**Answer**

The battery pack supplier has introduced controls relating to the installation of the busbar fixings such that assurance of correct installation is provided.

**Question 12**

What will JLR retailers / authorized repairers do to the vehicles?

**Answer**

Vehicles will have their [HV](#) battery busbar fixings inspected, and new components installed as required.

**Question 13**

Which vehicles are affected by this recall?

**Answer**

2019 model year to 2024 model year I-PACE vehicles as below may be affected:

SADHD2S19K1F61469 to SADHA2A1XR1638447\*

\* Specific vehicles within the VIN range

**Question 14**

Are other JLR models affected by these actions?

**Answer**

No other JLR models are known to be affected by this condition.

**Question 15**

Are parts available to rework vehicles?

**Answer**

Parts are available for JLR retailers / authorized repairers to conduct this repair.

**Question 16**

How much will the recall cost JLR?

**Answer**

Cost was not a factor in deciding to recall these vehicles.

**Question 17**

How do I know if my vehicle is affected?

**Answer**

All owners of potentially affected vehicles will shortly receive a letter inviting them to contact a JLR retailer / authorized repairer for the work to be completed.

**Question 18**

How long does it take for the vehicle to be inspected and repaired?

**Answer**

The work will be completed out as quickly and efficiently as possible in order to minimize inconvenience to customers and is expected to take around 18 hours to complete. Naturally, due to JLR retailer / authorized repairer schedules, vehicles may be required for longer.

**Question 19**

Can I continue to drive my vehicle safely until it has been recalled?

**Answer**

Customers are advised to contact a JLR retailer / authorized repairer should they have any concerns.

**Note:**

Make sure that any press enquiries are referred to the JLR Corporate Media office on +44-(0)2475-361000 or [jlrmmedia@jaguarlandrover.com](mailto:jlrmmedia@jaguarlandrover.com)