

# SAFETY RECALL

# SR24-82

Date      Expiration      Group      No.      Page  
02.2024      NA                1(11)

First Release

mm-dd-yy

DRAG LINK INSPECTION  
9700 (B13R)

## MODEL YEAR(S) AND VEHICLE SERIAL NUMBERS (VIN) INVOLVED

<b>NOTICE TO SERVICE CENTERS</b> <i>Verify vehicle eligibility by checking recall status with <b>SAP</b> or via <b>ONLINE WARRANTY SYSTEM</b> available on Service / Warranty tab of Prevost website.</i>	
<b>Model</b>	<b>VIN</b>
Volvo 9700 us/can Model Year : 2024	
This recall does not necessarily apply to all the above-mentioned vehicles, some vehicles may have been modified before delivery. The owners of the vehicles affected by this recall will be advised by a letter indicating the Vehicle Identification Number (VIN) of each vehicle concerned.	

## DESCRIPTION

On the vehicles affected by this recall, inspect drag link if need replace the drag link or replace the ball joint of drag link.

## MATERIAL

Order the following parts for inspection only (Part 1):

<b>Part No.</b>	<b>Description</b>	<b>Qty</b>
907861	SPLIT PIN 4X32	2

Order the following parts for inspection and drag link replacement (Part 2):

<b>Part No.</b>	<b>Description</b>	<b>Qty</b>
22627723	DRAG LINK	1
60112752	CASTLE NUT	2
907861	SPLIT PIN 4X32	2

# SAFETY RECALL

# SR24-82

Date      Expiration      Group      No.      Page  
02.2024      NA                2(11)

Order the following parts for inspection and ball joint replacement (Part 3):

Part No.	Description	Qty
21263821	BALL JOINT (LH)	1
22164949	SCREW AND NUT KIT	1
60112752	CASTLE NUT	1
907861	SPLIT PIN 4X32	2

## PROCEDURE

	<b>DANGER</b>
<p>Park vehicle safely, apply parking brake, stop the engine. In the battery box, set the battery cut-off switch to the OFF position prior to working on the vehicle.</p> <p>Lockout &amp; Tag out (LOTO) must be performed during set-up, maintenance or repair activities. Refer to your local procedure for detailed information regarding the control of hazardous energy.</p>	

## TABLE OF CONTENT

PART 1 - INSPECTION.....	3
PART 2 - DRAG LINK REPLACEMENT.....	6
PART 3 - BALL JOINT REPLACEMENT.....	9
PARTS / WASTE DISPOSAL.....	11
WARRANTY.....	11

## PART 1 - INSPECTION

1. Locate the drag link.

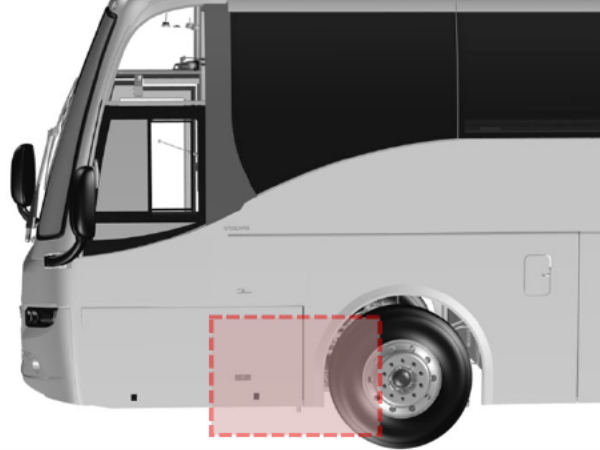

2. Lift the vehicle and support it on jack stands or perform the job on an inspection pit.

**NOTE**

*Follow the instructions carefully to avoid personal injury and damage to equipment. Negligence can lead to serious personal injury or death.*

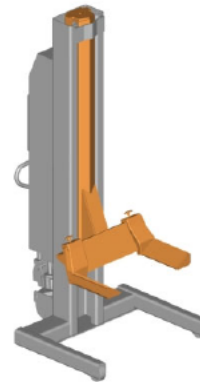

3. Check the relative play between both ball joints of the drag link and their joints to:

- Steering arm
- Pitman arm

**NOTE**

*To check the relative play in the ball joints, move them vigorously.*

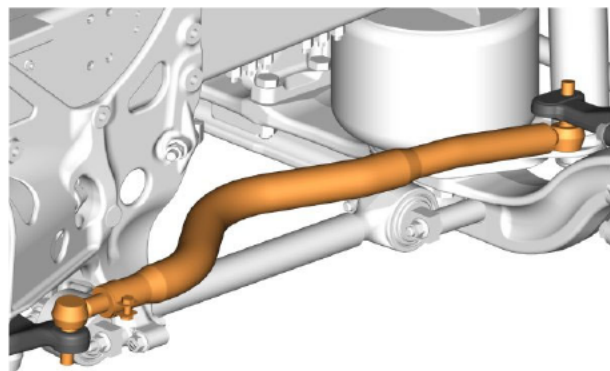

4. Disassembly the drag link from the steering arm and discard the split pin.
5. Verify the castle nut conditions.
  - If damage discard and replace by a new 60112752.
  - If no go to next step.
6. Verify drag link end thread conditions.
  - If damage discard and replace by a new 22627723 and go to drag link replacement section (PART 2).
  - If no go to next step.

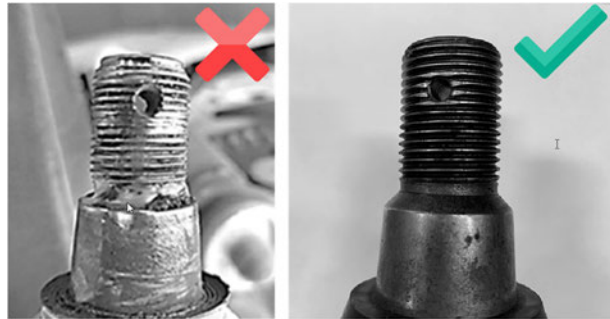
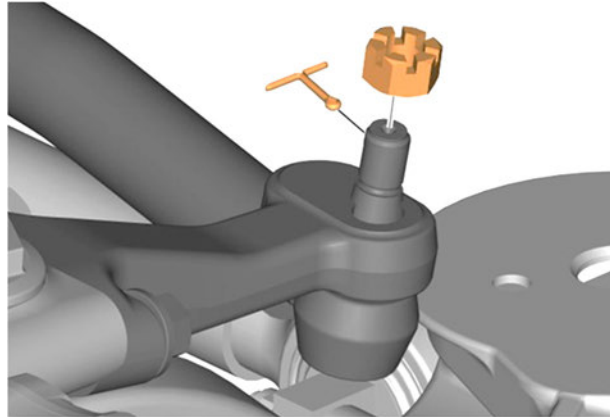

7. Install the castle nut 60112752 on the drag link from the steering arm.
8. Torque the castle nut to 200 Nm and up to the next split pin hole.
9. Install a new split pin 907861.

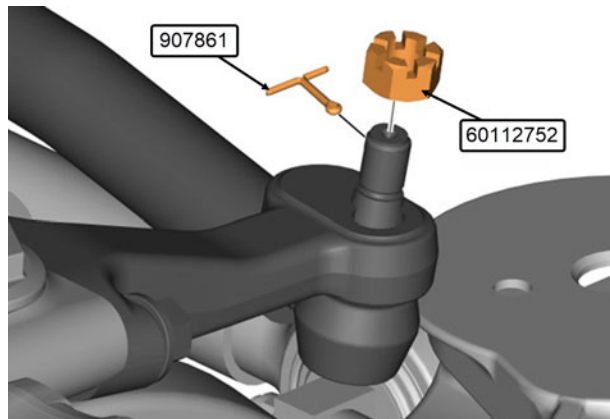

10. Disassembly the drag link from the pitman arm and discard the split pin.

11. Verify the castle nut conditions.

- If damage discard and replace by a new 60112752.
- If no go to next step.

12. Verify drag link end thread conditions.

- If damage, go to ball joint replacement section (PART 3).
- If no go to next step.

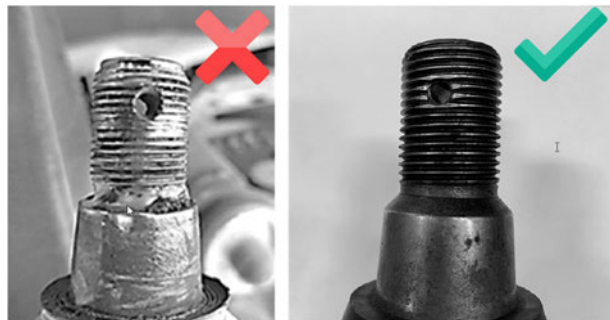
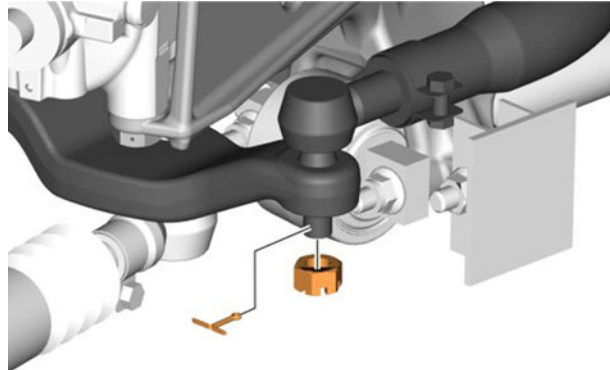

13. Install the castle nut 60112752 on the drag link from the pitman arm.

14. Torque the castle nut to 200 Nm and up to the next split pin hole.

15. Install a new split pin 907861.

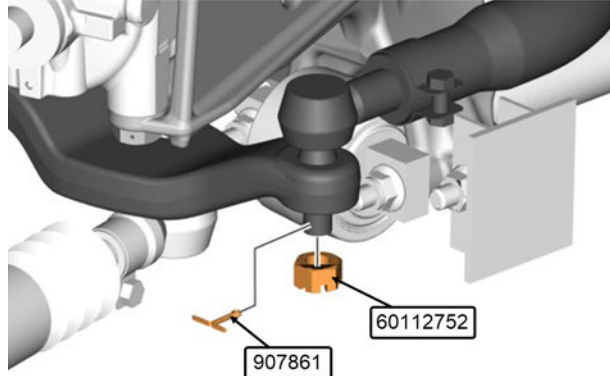

## PART 2 - DRAG LINK REPLACEMENT

1. Set the wheels to the straight-ahead position. Make sure the steering gear is in the straight-ahead position before loosening the drag link.
2. Secure the steering wheel so that it cannot turn.

**NOTE**

*The steering wheel must NOT be turned while the drag link is removed on busses with automatic steering limiter valves on the steering gear.*

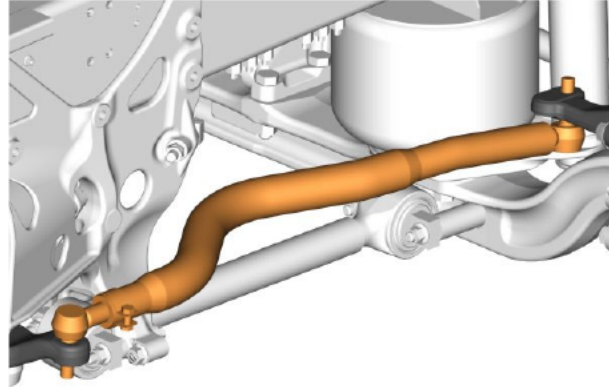

3. Remove castle nut and split pin the drag link from the steering arm and discard.

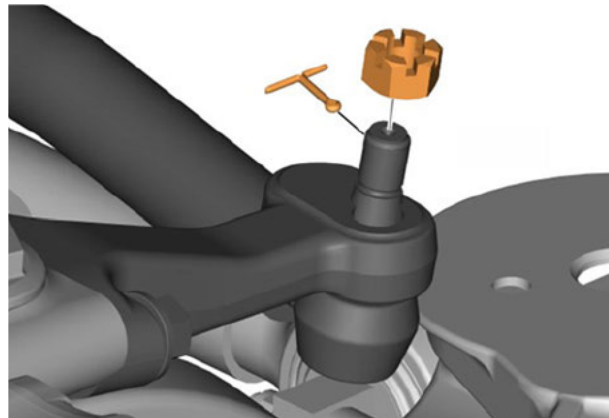

4. Disassembly the drag link from the steering arm with tool 9990814.

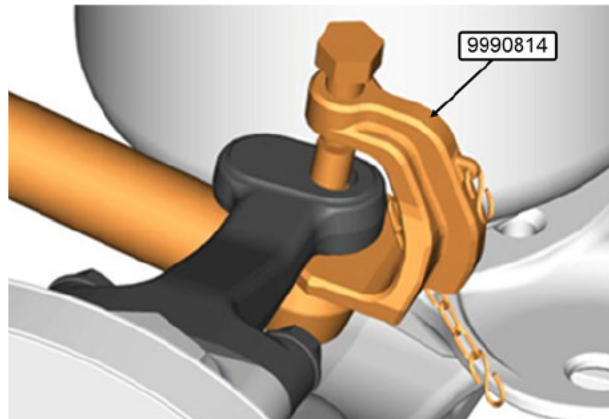

5. Remove castle nut and split pin from the pitman arm and discard.

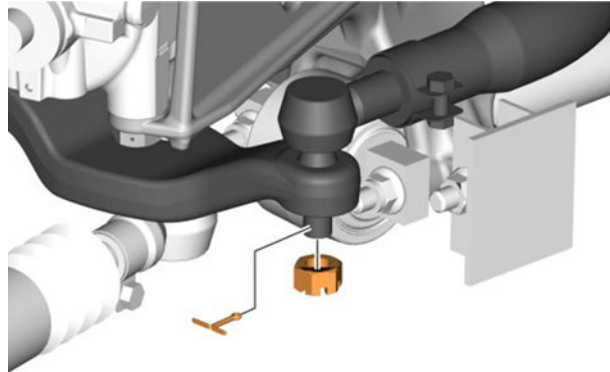

6. Disassembly the drag link from the pitman arm with tool 9990814.
7. Discard the drag link.

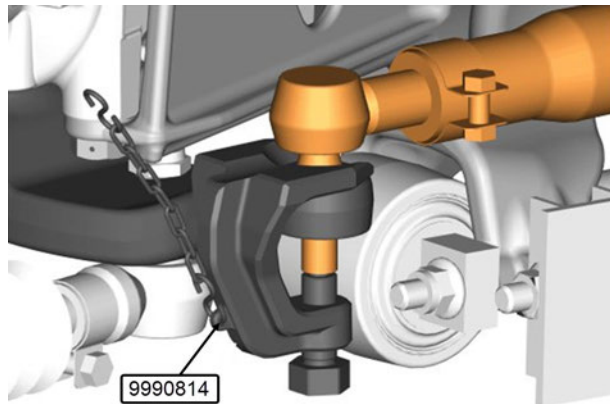

8. Install the new drag link assembly 22627723.

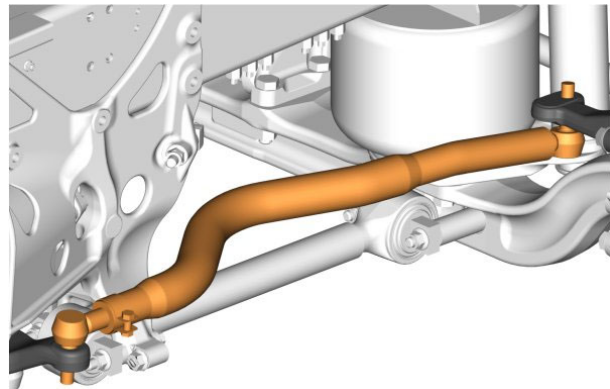

9. Install a new castle nut 60112752 on the drag link from the steering arm.
10. Torque the castle nut to 200 Nm and up to the next split pin hole.
11. Install a new split pin 907861.

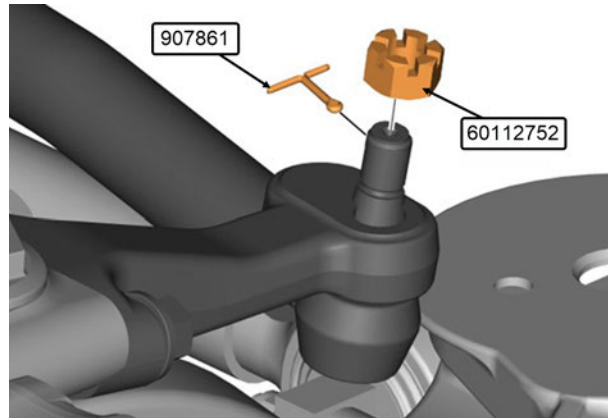

12. Adjust the drag link to the correct length 70mm (A) and fit it to the Pitman arm, checking that the steering gear is in the centre position. If not, adjust the drag link.

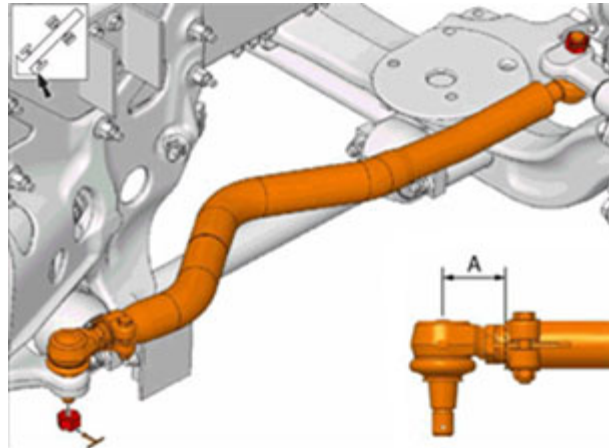

13. Torque screw and nut of the clamp to 170Nm.

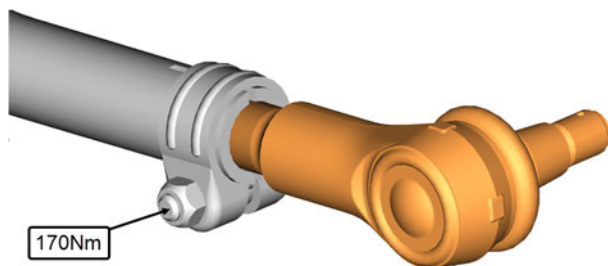

14. Install a new castle nut 60112752 on the drag link from the pitman arm.
15. Torque the castle nut to 200 Nm and up to the next split pin hole.
16. Install a new split pin 907861.

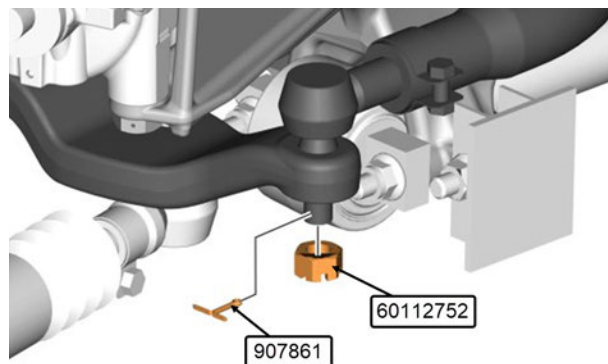



## PART 3 - BALL JOINT REPLACEMENT

1. Set the wheels to the straight-ahead position. Make sure the steering gear is in the straight-ahead position before loosening the drag link.
2. Secure the steering wheel so that it cannot turn.

### NOTE

*The steering wheel must NOT be turned while the drag link is removed on busses with automatic steering limiter valves on the steering gear.*

3. Remove the damage ball joint and the nut and the screw of the clamp and discard.
4. Install the new ball joint 21263821.

Install new screw and nut kit 22164949 on the clamp.

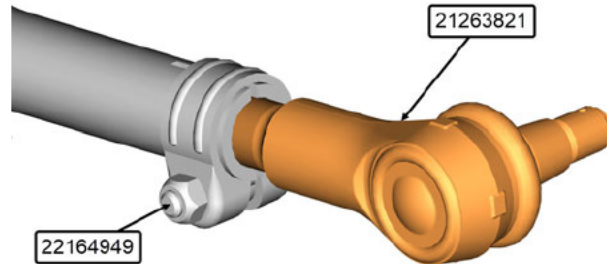

5. Adjust the drag link to the correct length 70mm (A) and fit it to the Pitman arm, checking that the steering gear is in the centre position. If not, adjust the drag link.

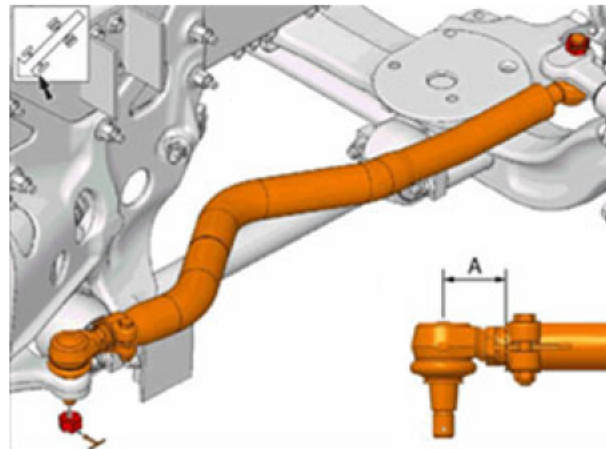

6. Torque screw and nut of the clamp to 170Nm.

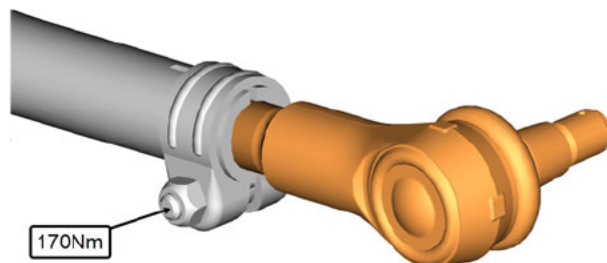

# SAFETY RECALL

# SR24-82

Date	Expiration	Group	No.	Page
02.2024	NA			10(11)

7. Install a new castle nut 60112752 on the drag link from the pitman arm.
8. Torque the castle nut to 200 Nm and up to the next split pin hole.
9. Install a new split pin 907861.

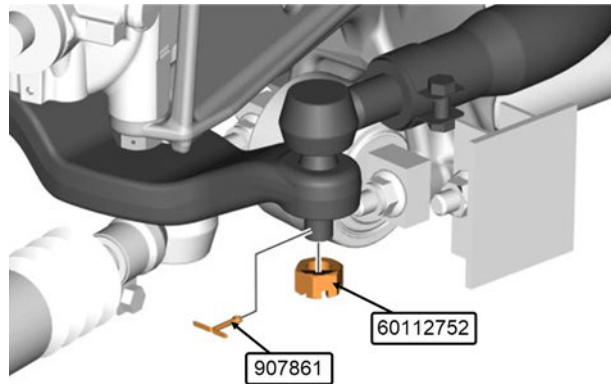

## PARTS / WASTE DISPOSAL

All replaced parts must be returned to Prevost according to the Return Shipping Instructions available on <https://www.prevostcar.com/content/warranty-documents> for full reimbursement. A copy of the warranty claim form must be enclosed with the shipment.

Discard waste according to applicable environmental regulations (Municipal/State[Prov.]/ Federal)

## WARRANTY

This modification is covered by Prevost's normal warranty. We will reimburse you the parts and labor as follows upon receipt of a completed A.F.A. Please submit claim via our Online Warranty System, available at [www.prevostcar.com](http://www.prevostcar.com) (under Service \ Warranty section). Use Claim Type: "Bulletin/Recall" and select "Safety Recall SR24-82".

Link inspection only

½ hour (0.5) of labor

Link inspection and replacement of the drag link

two hours (2.0) of labor

Link inspection and replacement of the ball joint

two hours (2.0) of labor

## OTHER

VBC Bulletin	C0836
Fail Code	14.05
Defect Code	09
Syst.Cond.	R
Causal Part	60112752

Access all our Service Bulletins on <http://prevostparts.volvo.com/technicalpublications/en/publications.asp> or scan the QR-Code with your smart phone.

E-mail us at [technicalpublications\\_prev@volvo.com](mailto:technicalpublications_prev@volvo.com) and type "ADD" in the subject to receive our warranty bulletins by e-mail.



Prevost engages in a continuous program of testing and evaluating to provide the best possible product. Volvo Bus, however, is not committed to, or liable for updating existing products.