



GROUP	MODEL
Safety Recall Campaign	2024MY Telluride (ON)
NUMBER	DATE
SC296	March 2024

SAFETY RECALL CAMPAIGN

Subject: **ENGINE SUB-ASSEMBLY REPLACEMENT (SC296)**

This bulletin provides information to replace the engine sub-assembly on certain 2024MY Telluride (ON) vehicles produced from October 1, 2023 through December 6, 2023. The engine valve springs in the subject vehicles may break while driving due to fatigue cracking as a result of damage to the springs during manufacture by the supplier. A broken valve spring may result in a loss of motive power. In rare cases, a hole in the engine block may occur due to a broken valve entering the combustion chamber. A loss of motive power increases the risk of crash. A hole in the engine block increases the risk of a fire. Customers may experience abnormal engine noise, check engine light illumination, and engine running rough. Follow the procedure outlined in this publication to replace the engine sub-assembly on the applicable vehicle. Before conducting the procedure, verify that the vehicle is included in the list of affected VINs.

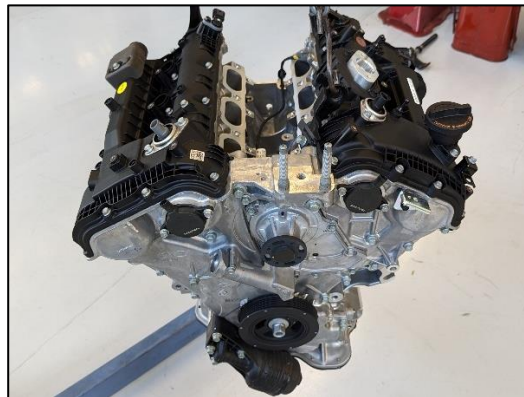

NOTICE

There is no charge to the vehicle owner for this repair. Under applicable law, you may not sell or otherwise deliver any affected vehicle until it has been repaired pursuant to the procedures set forth in this bulletin.

Repair status for a VIN is provided on KDealer+ (Service → Warranty Coverage → Warranty Coverage Inquiry → Campaign Information). Not completed Recall / Service Action reports are available on KDealer+ (Consumer Affairs → Not Completed Recall → Recall VIN → Select Report), which includes a list of affected vehicles.

Replacement Procedure:

 NOTICE

Be sure to review the instructions provided in this publication and reference KGIS for additional instructions as needed. FWD and AWD models will differ slightly.

1. Remove the engine sub-assembly by referring to “Engine Mechanical System → Engine and Transaxle Assembly → Engine and Transaxle Assembly → Removal and Installation” in the applicable Shop Manual on KGIS.

Include the removal of:

- Oil Level Gauge & Pipe

Note: Front drive axles (FWD & AWD) at brake rotors) and the three (3) rear propeller shaft mounting bolts (AWD only) were not removed.

 IMPORTANT

Using an lift table, allow the removed engine and transaxle assembly to rest on the table surface for disassembly. **Reference the KGIS shop manual for instructions to remove the transferable parts described in this publication.**

2. Remove the engine oil plug (A) located behind the right rear cylinder head.

Note: Do not lose/discard of the oil plug.

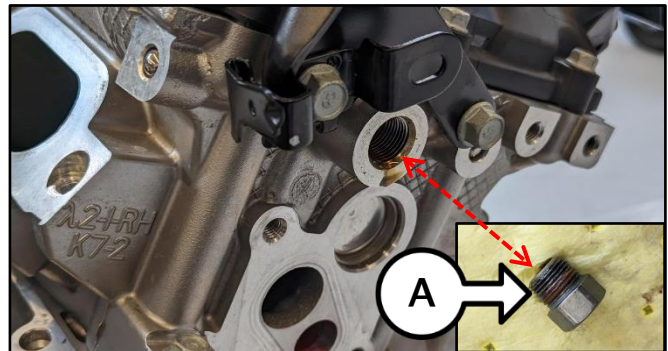

3. Remove the engine wire harness (B) by disconnect all connectors and retaining bolts from the engine.

Refer to [TSB ENG190](#) for information regarding engine replacement practices.

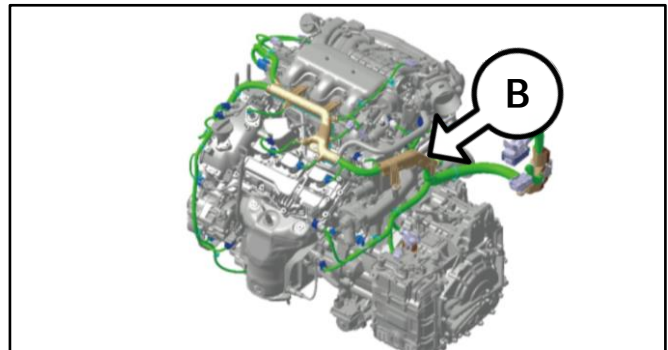

SUBJECT:

ENGINE SUB-ASSEMBLY REPLACEMENT REPLACEMENT (SC296)

4. Remove the drive belt (C), alternator (D), and air conditioner compressor (E).

Include the removal of:

- Drive Belt Tensioner
- Water Pump Pulley
- Idler(s)

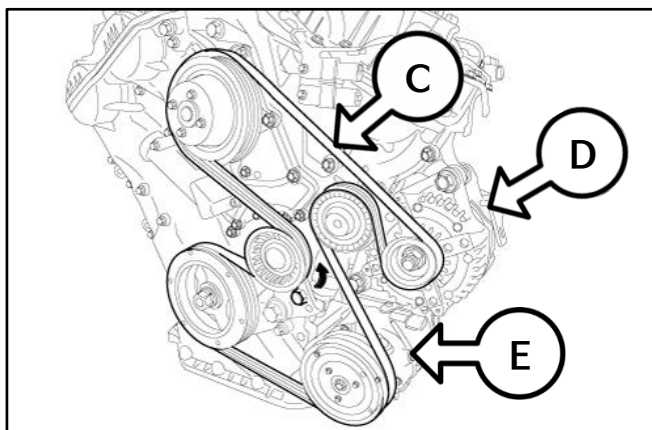

5. Remove the surge tank (F).

Refer to [TSB ENG083](#) for special attention and handling procedures of GDI-specific components.

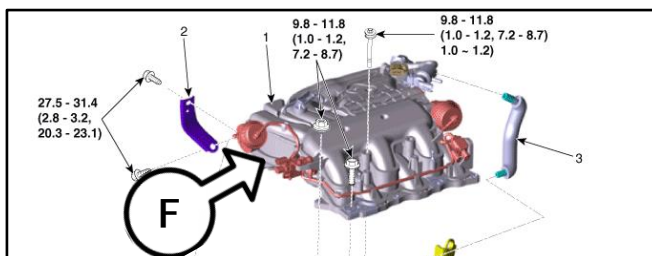

6. Remove the six (6) ignition coils (G) from both bank 1 and bank 2.

Note: The spark plugs do not need to be removed.

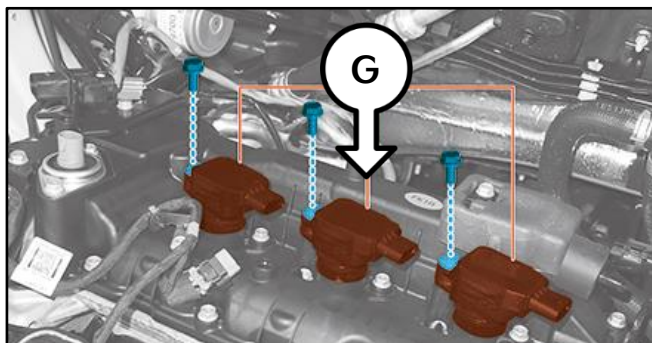

7. Remove the intake manifold (H).

Include the removal of:

- High Pressure Fuel Pump
- High pressure Fuel Pipe
- Delivery Pipe w/Injectors

Refer to [TSB ENG083](#) for special attention and handling procedures of GDI-specific components.

Note: Be sure not to lose/discard the water vent seal (I) located under the intake manifold.

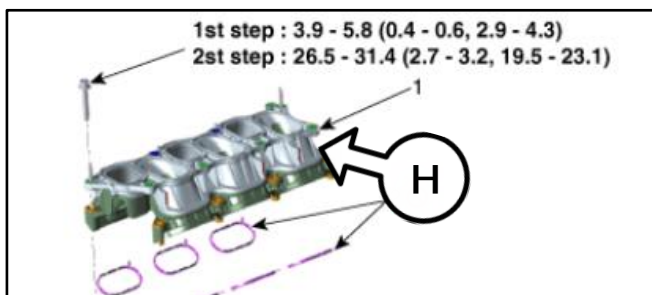

8. Remove the water temperature control assembly (J) and water center pipe (K).

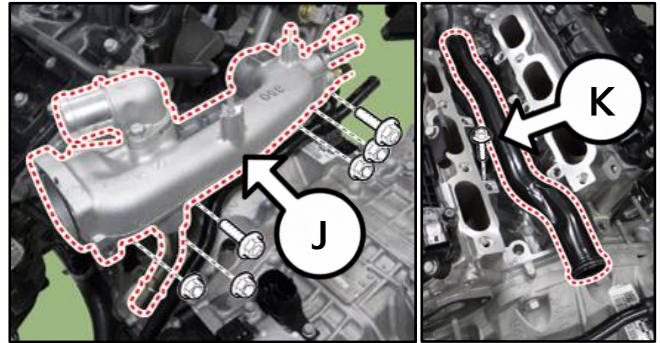

9. Remove the two (2) knock sensors (L) from both bank 1 and bank 2.

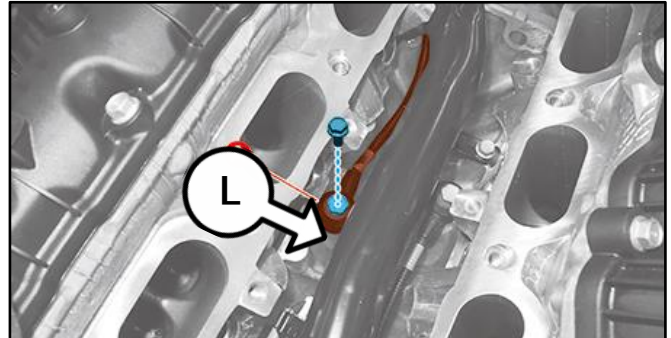

10. Remove the four water temperature control assembly retaining studs bolts (M) from the back of the cylinder heads.

Note: Do not lose/discard of the 4 stud bolts.

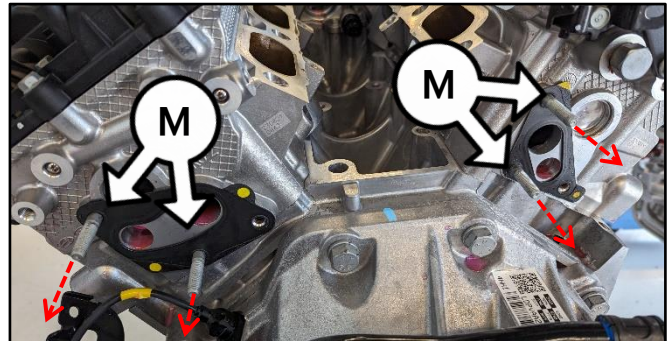

11. Remove both left and right side exhaust manifolds (N).

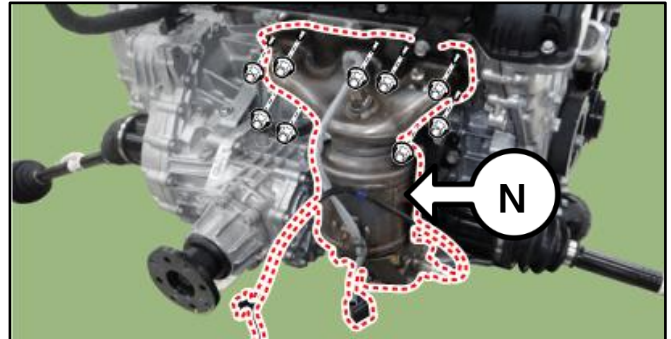

12. Remove the ignition starter assembly (O).

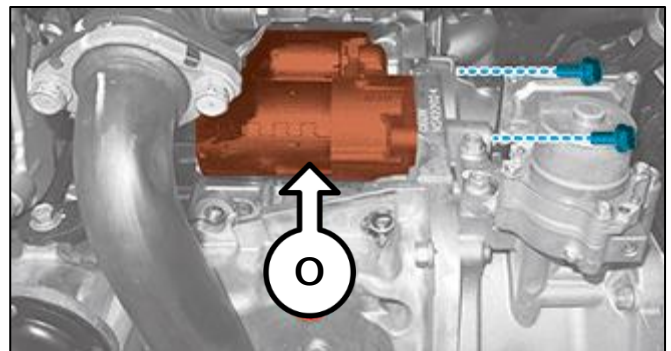

SUBJECT:

ENGINE SUB-ASSEMBLY REPLACEMENT REPLACEMENT (SC296)

If applicable (AWD models):

13. Remove the transfer assembly (P).

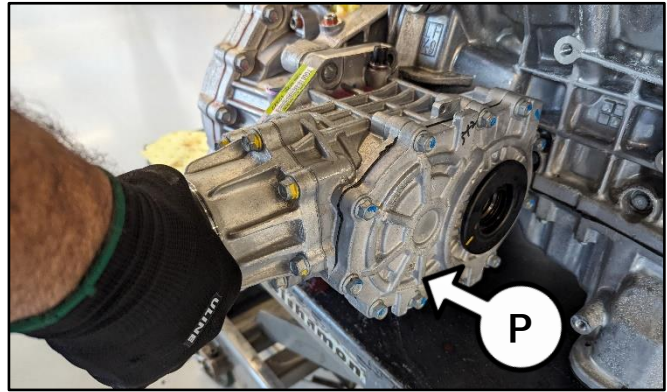

14. Separate the automatic transaxle assembly (Q) from the engine (R).

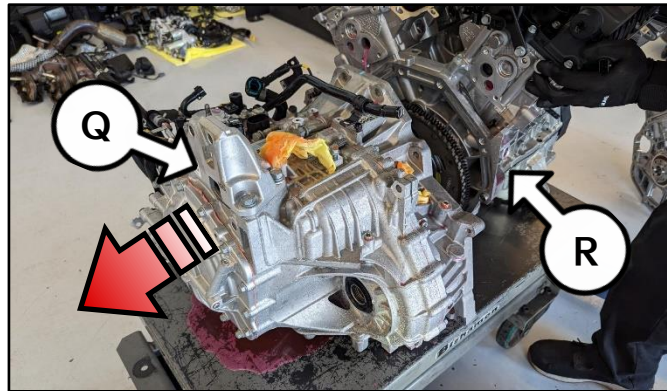

15. Loosen the eight (8) bolts to remove drive plate (S) from the engine.

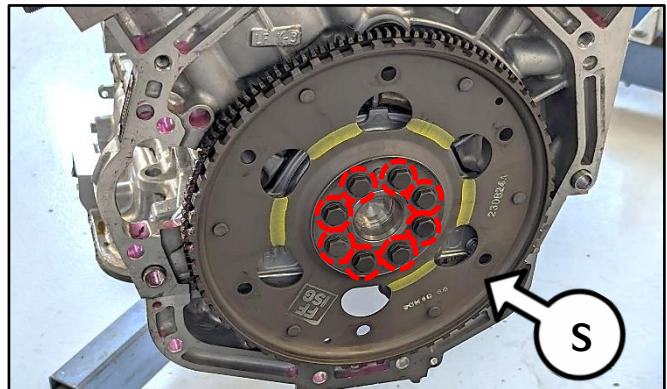

16. Remove the two (2) alignment sleeves (T) located on opposite sides of the engine using a push pin and hammer.

Note: Do not lose/discard of the 2 alignment sleeves.

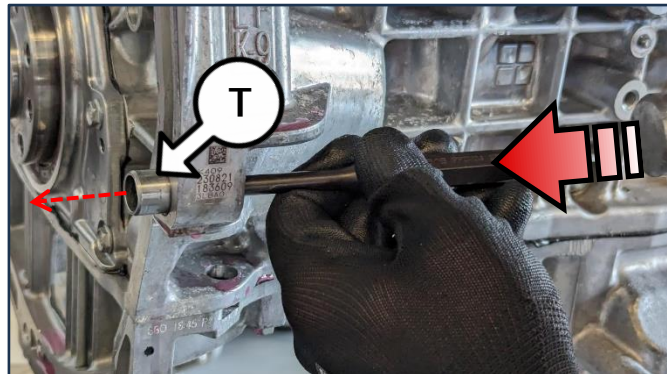

17. Replace the injector seals and related parts by referring to “Engine Control/Fuel System → Fuel Delivery System → Injector → Replacement” in the applicable shop manual on KGIS.

SST PN 09353 2B000

Note: Be sure to ALL of the parts included in the service kit or ordered separately.

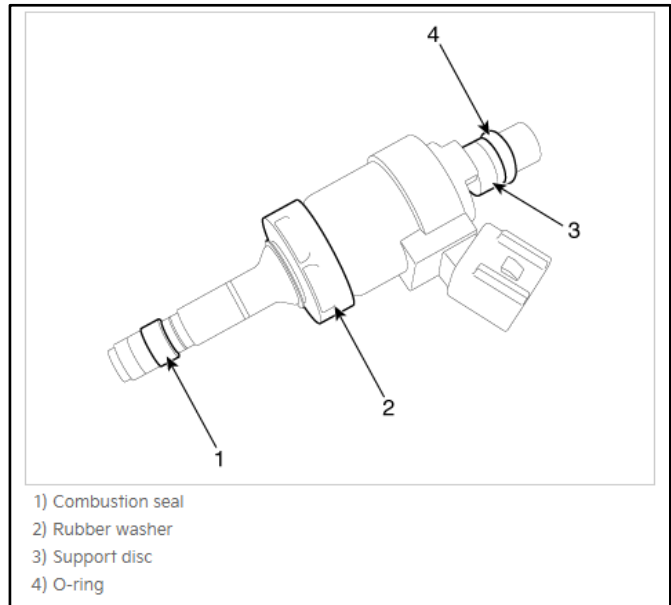

18. **BEFORE REASSEMBLY:** Be sure to re-install the two (2) alignment sleeves (from step 16) and the four (4) water temperature control assembly retaining studs bolts (from step 10), and the engine oil plug (from step 2) before re-assembly.
19. Reinstall the assembled engine and transmission/transaxle into the vehicle in the reverse order of removal using ALL of the supplied parts included in the applicable FWD/AWD engine assembly and service kit parts. Refer to parts table on page 7 and inventory on page 8.

AFTER REASSEMBLY:

- Fill crankcase with 5W-30 oil (refer to KGIS for oil fill level requirements)
 - Recommended Product: QUARTZ 9000 FUTURE FGC 5W-30 **Full Synthetic** SN PLUS, QUARTZ 9000 FUTURE XT 5W30 **Full Synthetic** SN PLUS, Mobil **Super Synthetic** 5W30 or above. If not available, use other brand 5W30 and **Full Synthetic** type with API SN/SN+/SP, ILSAC GF4/GF5 or higher service grade.
 - Fill and bleed the cooling system per KGIS instructions using 50/50 coolant or mixture appropriate for area.
 - Pressurize the fuel system before starting the vehicle.
 - Reset engine adaptive values and perform steering angle sensor calibration.
20. Verify normal operation of the vehicle with road test, and with the **engine 'ON' (running), erase any stored DTCs** (e.g., EPS, ESC, and TPMS) that may have been set by this procedure.
21. Verify no leaks exist and ensure engine oil and coolant are at their proper level.

SUBJECT:

ENGINE SUB-ASSEMBLY REPLACEMENT REPLACEMENT (SC296)**AFFECTED VEHICLE RANGE:**

Model	Production Date Range
Telluride (ON)	October 1, 2023 to December 6, 2023

REQUIRED PART:

Part Name	Part Number	Figure	Qty.
Engine Sub-Assembly (AWD)	170S1 3LS00QQK*		1
Engine Sub-Assembly (FWD)	169S1 3LS00QQK*		

Part Name	Part Number	Comments	Qty.
Service Kit (Refer to page 8 parts inventory)	21111 3LS14QQK*	AWD	1
	21111 3LS12QQK*	FWD	

Part Name	Part Number	Comments	Qty.
Engine Oil	NPNEG5W30	5w30	7 Qts.
Coolant	UM020 CH263	50/50	2 Gal.
High Pressure Fuel Pipe	35305 3L100	Not included in kits at this time (Must be Ordered Separately)	1
Cross Over Pipe	353073 L000		1
Injector O-Ring	35312 2E610		6
Injector Backup O-Ring	35312 2E611		6
Combustion Seal Ring	35312 2E613		6

Note: Depending on engine part availability, you may receive an engine assembly with some components pre-installed or parts typically included in the separate Service Kit. Dealers will be billed for the Service Kit. Please use the information provided in the warranty table listed on page 4 to claim the Service Kit Part Number. When necessary, manually enter sublet code 'X2' for reimbursement of one roundtrip rideshare expense or up to three (3) days of rental for engine replacement. Attach supporting documentation. Parts supply is limited - DO NOT order for stocking purposes. A valid VIN is required when ordering an engine sub assembly and service kit.



SUBJECT:

ENGINE SUB-ASSEMBLY REPLACEMENT REPLACEMENT (SC296)

SERVICE KIT PART INVENTORY:

(Included parts in kits, DO NOT Order Separately unless specified)

Part Name	Part Number	Comments	Qty.	
Exhaust Gasket Pipe	28751 2B550	FWD	1	
Exhaust Gasket Pipe	28751 C5100	AWD	2	
Front Propeller Shaft Bolt	11435 10256K		4	
Rear Propeller Shaft Bolt	49129 C5200		3	
Steering U-Bolt	56415 L1000		1	
Roll Rod Bracket Bolt	11435 12006KA	FWD/AWD	1	
Gasket-Exhaust Pipe	28751 3S100		1	
Tie Rod End Nut	55259 2M000		2	
Nut-Castle	49551 4T000		2	
Clip-Fuel Injector	35309 3L000		6	
Washer-Injector Brkt	35313 3L000		6	
O-Ring	35322 3L000		1	
High Pressure Pump Bolt	11405 06206K		2	
BOLT - Flange	11403 08506K		6	
Oil Level Gauge Pipe O-Ring	26614 2B000		1	
Gasket-Throttle Body	35101 3C000		1	
Gasket-Exhaust Manifold,Lh	28521 3C702		1	
Gasket-Exhaust Manifold,Rh	28521 3C712		1	
Gasket-Surge Tank	29215 3CFA1		1	
Gasket-Inlet Manifold	28215 3CFA0		6	
Mounting Flange Nut Self Locking	51759 F6000		3	
Thermostat Case Gasket Lh	25614 3L100		1	
Thermostat Case Gasket Rh	25614 3L150		1	
Cross-Over Coolnat Pipe O-Rings	25462 35504		2	
Drive Plate Bolt	23311 35050		8	
High Pressure Fuel Pipe	35305 3L100		FWD/AWD Not included in kits at this time. (Must Order Separately)	1
Cross Over Pipe	353073 L000			1
Injector O-Ring	35312 2E610			6
Injector Backup O-Ring	35312 2E611			6
Combustion Seal Ring	35312 2E613			6



SUBJECT:

ENGINE SUB-ASSEMBLY REPLACEMENT REPLACEMENT (SC296)

WARRANTY INFORMATION:

N Code: N99 C Code: C99

Claim Type	Causal P/N	Qty.	Repair Description	Labor Op Code	Op Time	Replacement P/N	Qty.
R	22221 3L310	0	(SC296) Engine Sub-Assembly Replacement (FWD)	241A08R0	8.4 M/H	169S1 3LS00QQK	1
						21111 3LS12QQK	
						NPNENG5W30	7
						UM020 CH263	2
						35305 3L100	1
						353073 L000	
						35312 2E610	6
						35312 2E611	
						35312 2E613	
R	22221 3L310	0	(SC296) Engine Sub-Assembly Replacement (AWD)	241A08R1	8.7 M/H	170S1 3LS00QQK	1
						21111 3LS14QQK	
						NPNENG5W30	7
						UM020 CH263	2
						35305 3L100	1
						353073 L000	
						35312 2E610	6
						35312 2E611	
						35312 2E613	

Note: Refer to [Warranty Bulletin 2024-08](#) for claim submission procedures. Depending on engine part availability, you may receive an engine assembly with some components pre-installed or parts typically included in the separate Service Kit. Dealers will be billed for the Service Kit. Please use the information provided in the warranty table listed above.

 NOTICE

VIN inquiry data for this repair is provided for tracking purposes only. Kia retailers should reference [SC296](#) when accessing the KDealer+ system.

