



SAFETY RECALL

— Confidential and Proprietary —

Release Date: February 08, 2024

IND

Communication #: I-24-03

Expiration Date: No Expiration Date

Model Year(s): 2019-2022

VERSION: R03 (January 22, 2025)

IMPORTANT STOP SALE SAFETY NOTICE!

Revision	Release Date	Update
R01	2/8/2024	Safety Recall Release
R02	2/21/2024	Repair Procedure Updated
R03	1/22/2025	Canada Models Added. No changes for motorcycles in the United States.

If you are working with a printed copy, please verify you have the most current version of this document.

SUBJECT: ANTI-LOCK BRAKE (ABS) SOFTWARE UPDATE

PURPOSE

Indian Motorcycle has determined that some Model Year 2019-2020 and 2022 FTR, Model Year 2020-2022 Challenger and Model Year 2022 Pursuit motorcycles, equipped with a specific Anti-Lock Brake System (ABS) module may experience inadvertent brake light illumination, which increases the risk of a crash and serious injury. This can occur without rider input during certain limited riding conditions when a momentary loss of wheel contact with the ground occurs.

Indian Motorcycle has released this Safety Recall to update the ABS module with new software.

NOTICE

UNITED STATES DEALERS: on 02/08/2024, Indian Motorcycle auto-shipped an ABS reflash jumper harness for Challenger and Pursuit models and tracking info was posted to DEX.

NOTICE

CANADA DEALERS: Indian Motorcycle will be auto-shipping an ABS reflash jumper harness for Challenger and Pursuit models, starting 01/22/2025, and tracking info will be posted to DEX.

AFFECTED MODELS

MODEL YEAR	MODELS	VEHICLE IDENTIFICATION NUMBER RANGE
2019-2020 and 2022	FTR	Reference Unit Inquiry on the dealer website or the Service Communications list on the STOP site to lookup affected VINs.
2020-2022	Challenger	
2022	Pursuit	

The information contained within this document is confidential and protected by U.S. and international copyright laws, and is the property of Polaris Inc. This document is provided for the sole use of authorized Polaris dealers and distributors. This document is not to be distributed, duplicated, or copied, digitally or otherwise, without the written consent of Polaris Inc.

CUSTOMER NOTIFICATION

Dealers are required to review their sales records and make arrangements with customers for Recall completion. In addition to consumer units, dealers are required to correct any affected units in their inventory. Indian Motorcycle will be mailing a notification letter to consumers affected by this Recall. Indian Motorcycle will also send an email to owners for whom Indian Motorcycle has a valid email address.

CONTACT POLARIS

If you have questions that are not addressed in this document or in the Safety Recall FAQ, contact Indian Motorcycle Service through Ask Polaris or by phone at 877-204-3697.

DEALER - WHAT TO DO?

UNITED STATES: As of February 08, 2024, **YOU MUST NOT SELL OR DELIVER** any **NEW OR USED Model Year 2019-2020 and 2022 FTR, Model Year 2020-2022 Challenger and Model Year 2022 Pursuit motorcycles** affected by this **Stop Sale** until it is repaired according to the **Safety Recall**.

CANADA: As of January 22, 2025, **YOU MUST NOT SELL OR DELIVER** any **NEW OR USED Model Year 2019-2020 and 2022 FTR, Model Year 2020-2022 Challenger and Model Year 2022 Pursuit motorcycles** affected by this **Stop Sale** until it is repaired according to the **Safety Recall**.

WARRANTY CLAIM INFORMATION

2019, 2020, AND 2022 FTR MODELS	
Bulletin	I-24-03-AA
Claim Type	SB (Service Bulletin)
Labor Allowance	0.3 hours (18 minutes)
Part Number / Description	0000541 (QTY 1) Bulletin Misc Labor
Parts Availability	NA
University of Polaris Video Training Required	NO

2020-2022 CHALLENGER, AND 2022 PURSUIT MODELS	
Bulletin	I-24-03-BA
Claim Type	SB (Service Bulletin)
Labor Allowance	0.4 hours (24 minutes)
Part Number / Description	0000541 (QTY 1) Bulletin Misc Labor
Parts Availability	NA
University of Polaris Video Training Required	NO

Claim Submission:

- **US / Canada Dealers:** On DEX, go to Service and Warranty > Start a New Warranty Claim. Select Service Bulletin > Enter the VIN / PIN and Retrieve Registration. Select Indian Motorcycle® I-24-03 and Send Claim.

[Click here to start a Warranty Claim](#)

ACCESSORY LABOR

Polaris will review coverage of labor for the removal and installation of accessories required to complete the work in this communication. Follow the steps below to request reimbursement:

1. Start a new Ask Polaris Case, Service & Warranty Question.
2. Supply written description and pictures of the accessories to support the labor time requested.

COVERAGE PERIOD

Coverage will begin on February 08, 2024. This bulletin has no expiration date.

FEEDBACK FORM

A feedback form has been created for the technician to provide Polaris with an overall satisfaction rating for the instructions, provide comments on your experience or upload pictures/video. The form is viewable on mobile devices by scanning the QR code or on a PC by clicking [HERE](#).



I-24-03-AA REPAIR PROCEDURE – FTR MODELS

TOOLS REQUIRED

- Digital Wrench® II
- MultiLink XP cable
- Battery Tender (minimum 2 amps)

FTR ABS REFLASH REPAIR PROCEDURE

1. Park motorcycle on a flat surface, fully extend side stand, and make sure vehicle is stable.
2. Turn off the motorcycle.
3. Connect the battery tender to the motorcycle.
4. Connect the MultiLink XP cable to the PC and motorcycle. Then power on the motorcycle. Do **NOT** start.
5. Verify that the latest version of Digital Wrench II has been installed on your PC or laptop. For installation instructions, Click [HERE](#) to view the Digital Wrench II user manual or visit “Other Publications” on the left navigation menu of the DEX/iDEX STOP site.

Verify that your multilink has been set up to Direct to USB.

CAUTION

Make sure the vehicle has sufficient battery voltage and is connected to a battery tender before the reflash. Failure to do so may result in a reflash crash and damage the ECM.

6. Open Digital Wrench II and select “Auto Identify”.

NOTICE

Make sure the VIN, Model Year, Line, and Model are correct.



7. Select “Vehicle Update”.

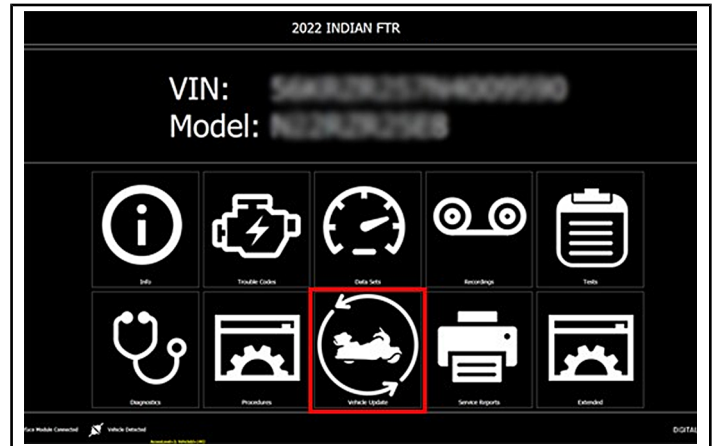

8. Click “Continue”.

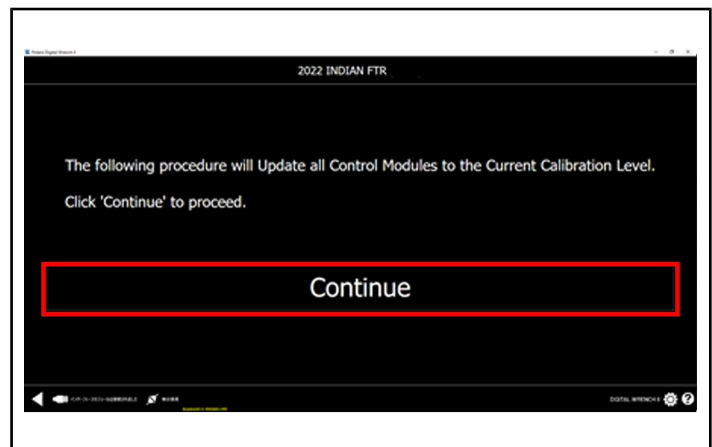

9. Select “ABSSTABILITY”, and then click “Update ECU (s)”.

NOTICE

Selecting "ABSSTABILITY" will ONLY update the ABS module software. Select other controllers, such as ECM, to also update.

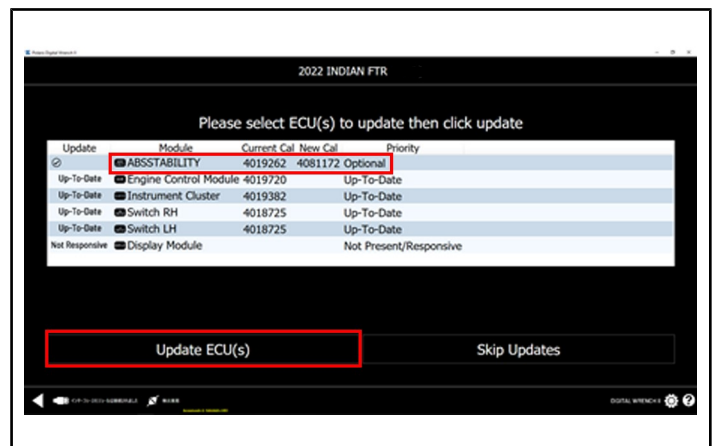

10. Once the update is complete, power cycle the motorcycle.

NOTICE

4081171 or 4081172 (depending on model) ABS Module software is now installed.

NOTICE

ONLY the ABS module software has been updated. It is suggested to verify the other controllers have up-to-date software.

11. Disconnect the battery tender and MultiLink XP cable from the motorcycle, and cap the diagnostic port.

SUBMITTING A CLAIM

Click the link below to start a Warranty Claim. Select **I-24-03-AA**

- US / Canada Dealers: [Click here to start a Warranty Claim](#)

I-24-03-BA REPAIR PROCEDURE – CHALLENGER/PURSUIT MODELS

TOOLS REQUIRED

- Digital Wrench® II
- MultiLink XP cable
- Battery Tender (minimum 2 amps)
- ABS Reflash Harness (Indian Motorcycle PN 2416838)
 - Provided by Indian Motorcycle February 2024
- 6 mm hex socket and ratchet

CHALLENGER/PURSUIT ABS REFLASH REPAIR PROCEDURE

1. Park motorcycle on a flat surface, fully extend side stand, and make sure vehicle is stable.
2. Turn off the motorcycle.
3. Connect the battery tender to the motorcycle.
4. Verify that the latest version of Digital Wrench II has been installed on your PC or laptop. For installation instructions, Click [HERE](#) to view the Digital Wrench II user manual or visit “Other Publications” on the left navigation menu of the DEX/iDEX STOP site.

Verify that your multilink has been set up to Direct to USB.

⚠ CAUTION

Make sure the vehicle has sufficient battery voltage and is connected to a battery tender before the reflash. Failure to do so may result in a reflash crash and damage the ECM.

5. Obtain the ABS Reflash Harness (Indian Motorcycle PN 2416838).

NOTICE

This tool was provided by Indian Motorcycle and shipped to the dealers February 2024.



6. Remove left upper side cover ②.

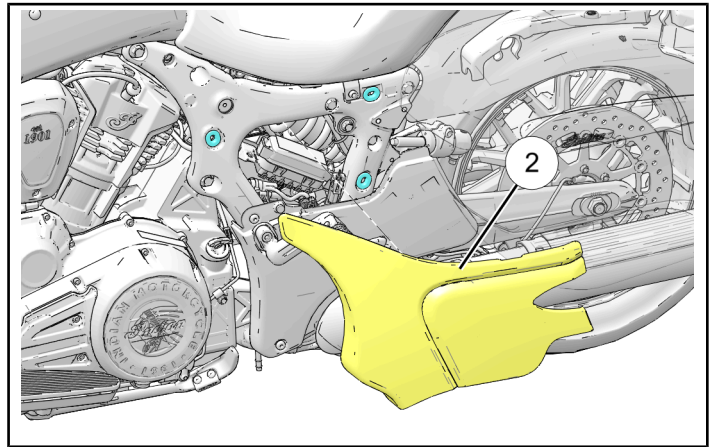

7. Remove right upper side cover ②.

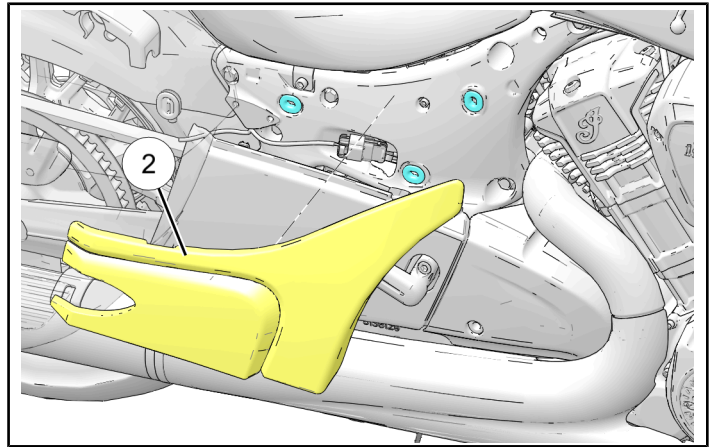

8. Remove seat fastener ①.

⚠ CAUTION

Pursuit models have wires routing through the seat.

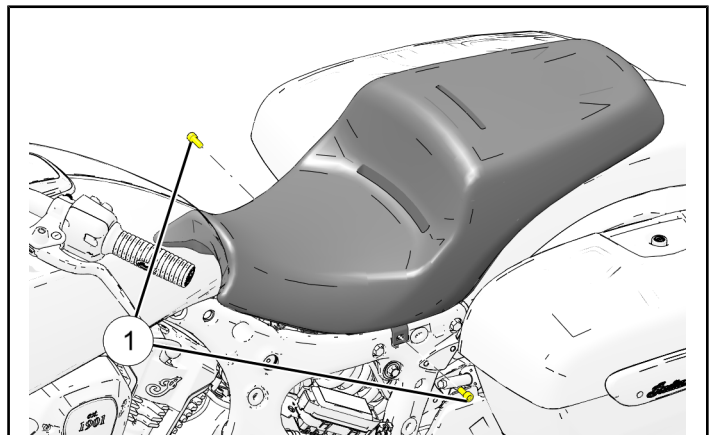

9. If equipped, disconnect seat electrical connector.

10. Remove the seat backward and up to remove.

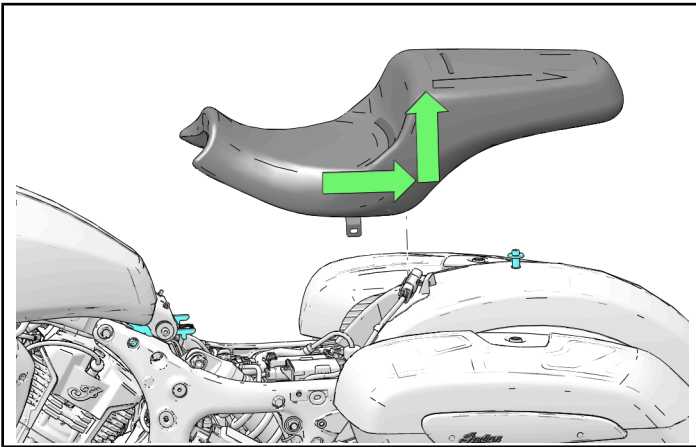

11. Connect the MultiLink XP cable to the PC and motorcycle. Then power on the motorcycle. Do **NOT** start.

12. Open Digital Wrench II and select “Auto Identify”.

NOTICE

Make sure the VIN, Model Year, Line, and Model are correct.

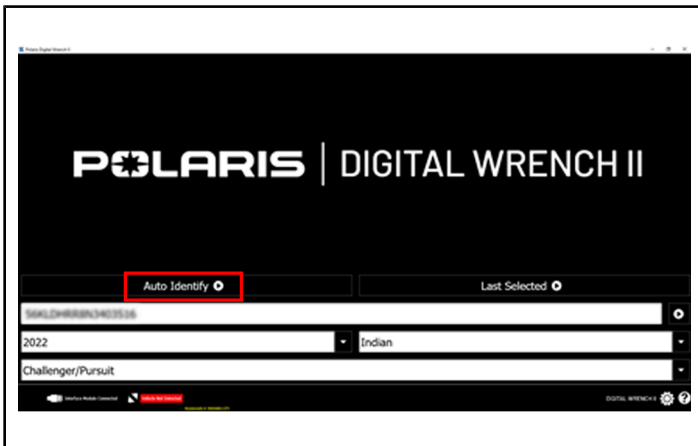

13. Select “Procedures”, and then select “ABS Update”.

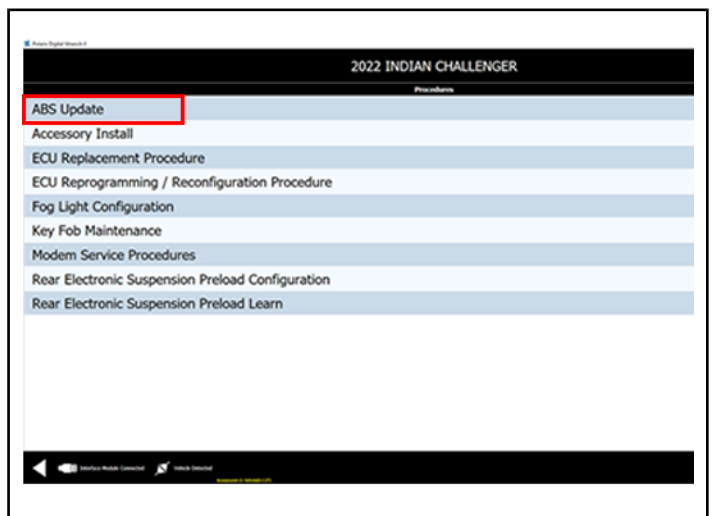

14. Select “Continue”.

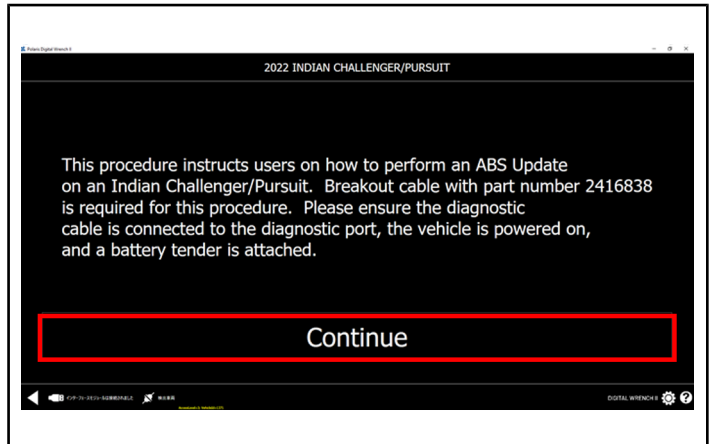

IMPORTANT

Do **NOT** select the next “Continue” until the ABS Reflash Harness is installed.
Instructions to install the ABS Reflash Harness is outlined in steps 15 – 17.

15. Locate and disconnect the ABS harness connector in the under-seat area that is taped to the trunk harness, located near the coolant line.

NOTICE

You may have to slide the WCM out of the retention bracket (2), using the WCM retention bracket release (3), to get better access to the ABS harness connector. Do **NOT** disconnect the WCM.

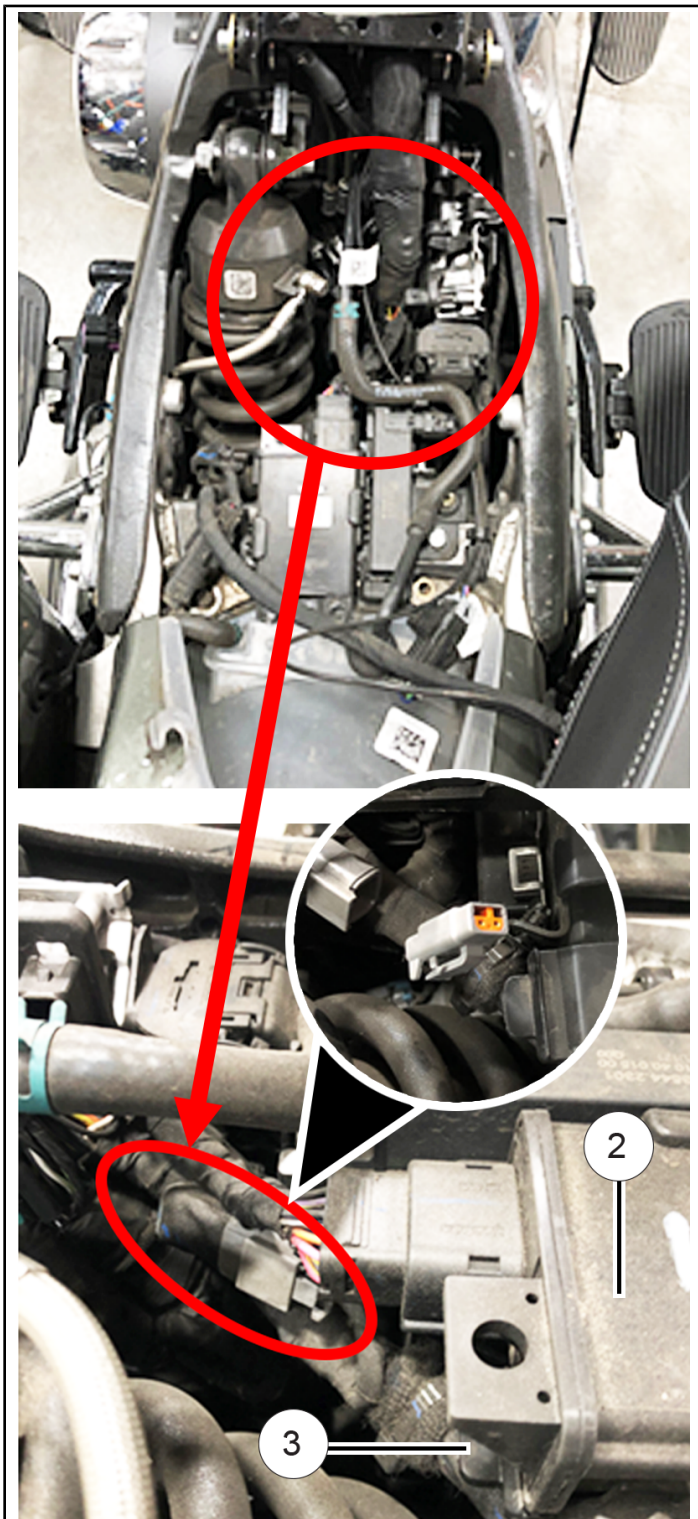

16. Disconnect the Multilink XP Cable from the diagnostic port on the motorcycle, and connect it to the ABS Reflash Harness (4).

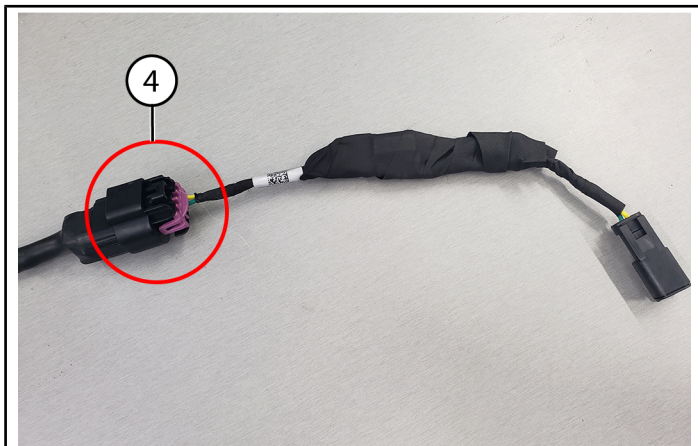

17. Connect the ABS Reflash Harness to the ABS harness connector on the motorcycle (5).

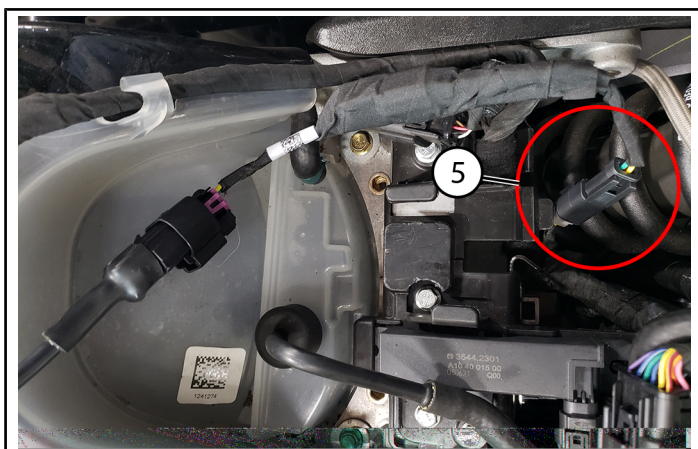

18. Once the harness is installed, NOW select "Continue".

IMPORTANT

If you select "Continue" before installing the harness, you will receive an error and have to start over.

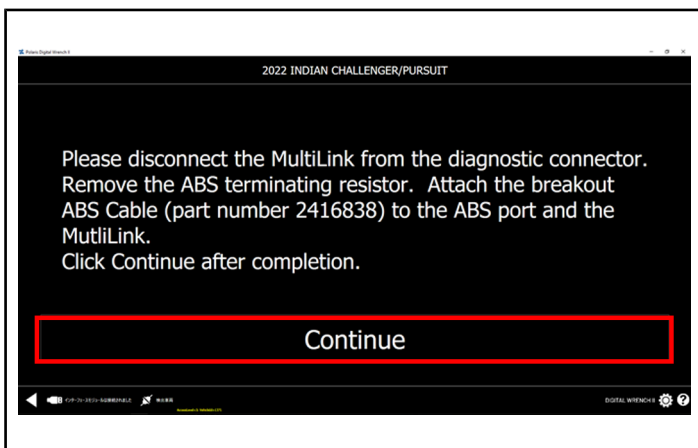

19. The ABS module will now update. Once the update has been successfully completed, select "Continue".

NOTICE

This special procedure **ONLY** updates the ABS module software. It is suggested to verify the other controllers have up-to-date software through the Vehicle Update function.

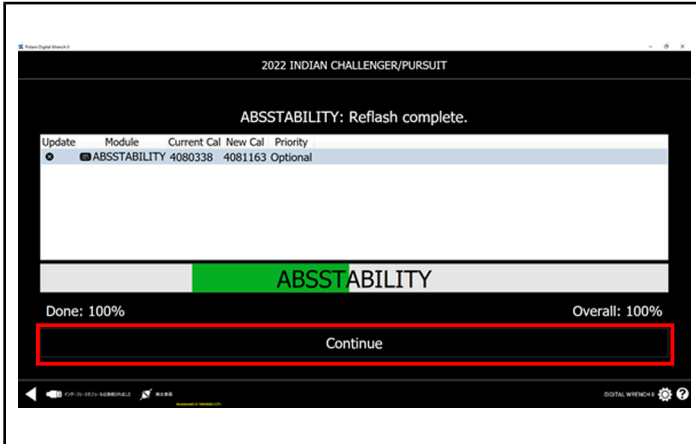

20. Disconnect the ABS Reflash Harness from the ABS harness connector on the motorcycle.

Select "Continue" **AFTER** the following actions have been completed.

NOTICE

An error will be received if this step is not completed as directed below.

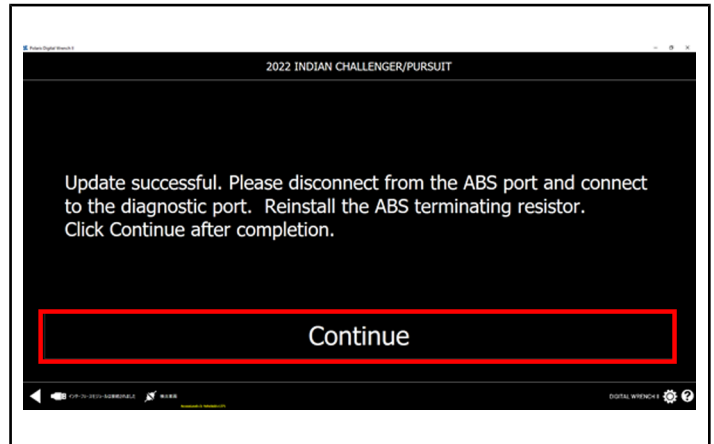

Reconnect the ABS harness connector (terminating resistor) on the motorcycle to the original connector, and reinstall the WCM into the retention bracket (if removed previously).

Connect the MultiLink back in to the diagnostic port **before** selecting "Continue".



21. Once the update is complete, power cycle the motorcycle.

NOTICE

4081163 ABS Module software is now installed.

NOTICE

ONLY the ABS module software has been updated. It is suggested to verify the other controllers have up-to-date software through Vehicle Update.

22. Disconnect the battery tender and Multilink XP Cable from the motorcycle, and cap the diagnostic port.

23. If equipped, connect the seat electrical connector.

24. Install seat down and forward.

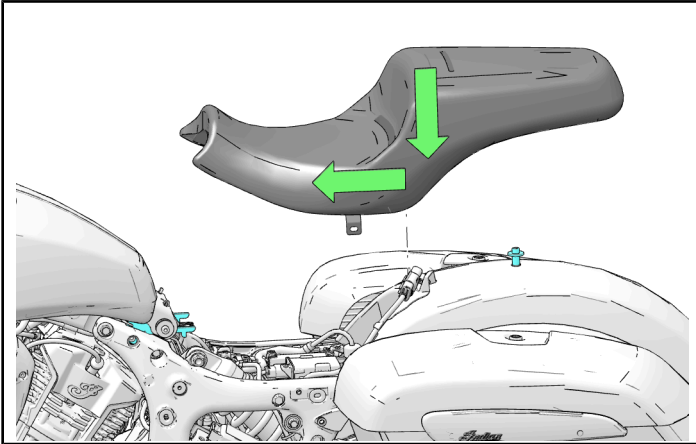

25. Install seat fastener ①.

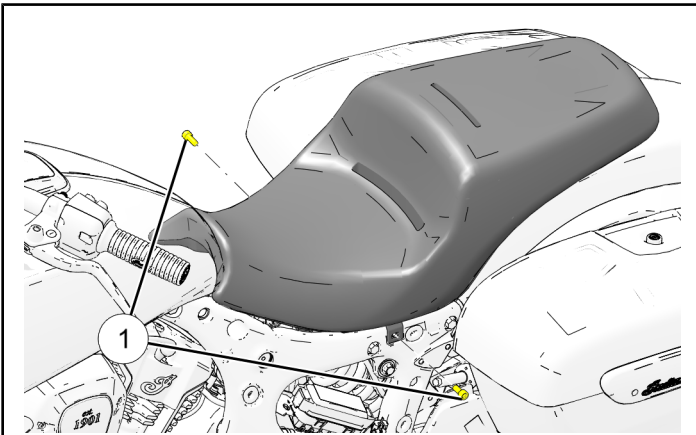

TORQUE

Seat Fastener:
18 ft-lbs (24 N·m)

26. Install right upper side cover ②.

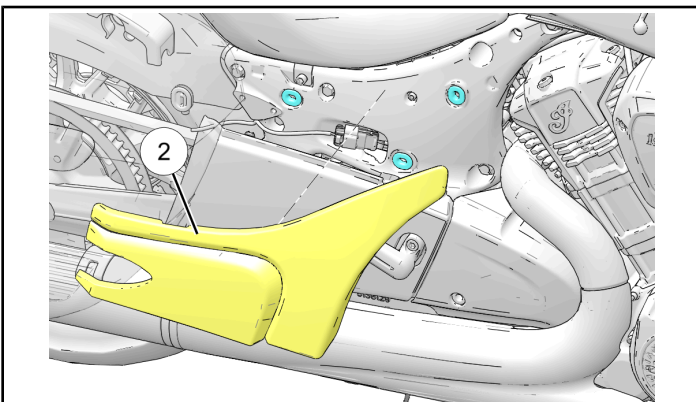

27. Install left upper side cover ②.

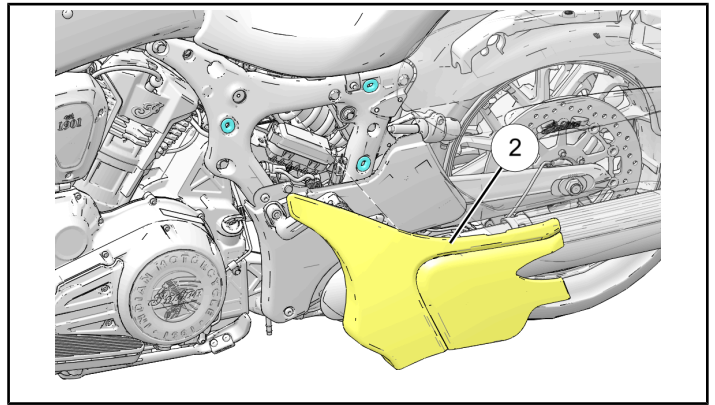

SUBMITTING A CLAIM

Click the link below to start a Warranty Claim. Select **I-24-03-BA**

- US / Canada Dealers: [Click here to start a Warranty Claim](#)

REFERENCE INFO

ADDITIONAL REFERENCE INFORMATION

For additional reference information not included in the document, click [HERE](#).

FAQS

Frequently Asked Questions (FAQs) related to this recall can be found at the end of the .pdf document.



Indian Motorcycle I-24-03 Safety Recall ABS Software Update

Version: R02 (February 21, 2024)

What is the purpose of the I-24-03 Safety Recall?

Indian Motorcycle has determined that some Model Year 2019-2020 and 2022 FTR, Model Year 2020-2022 Challenger and Model Year 2022 Pursuit motorcycles, equipped with a specific Anti-Lock Brake System (ABS) module may experience inadvertent brake light illumination. This can occur without rider input during certain limited riding conditions when a momentary loss of wheel contact with the ground occurs. Which increases the risk of a crash and serious injury.

Indian Motorcycle has released the I-24-03 Safety Recall to update the ABS module with new software.

What make & model year is included in this Safety Recall?

Some Model Year 2019-2020 and 2022 FTR, Model Year 2020-2022 Challenger and Model Year 2022 Pursuit motorcycles. Note some units may already have the correct software and have been removed from the affected population.

How can a dealer see which unregistered units in inventory are impacted by this?

1. Login to the dealer website (DEX).
2. Locate the 'Service and Warranty' dropdown, click on STOP Site.
3. On the left-hand side of the page, under 'STOP Site Links,' click on 'Service Communications'.
4. Locate the link for the bulletin of interest and click on the 'All VINs' link located on the right.
5. The 'All VINs' page will display all affected VINs within your dealership's inventory.

NOTE: Unit Inquiry can always be used to check an individual VIN.

Will Indian Motorcycle notify consumers?

Yes. Indian Motorcycle will notify consumers of the repair release by email, text message and follow-up with a mailed letter.

Should dealers notify consumers?

Yes. Dealers should follow their standard process for contacting consumers regarding recall work on their affected vehicles. Dealers should reference the STOP site for a list of their dealership's affected VINs.

Is training required before ordering parts or filing claims for this Safety Recall?

No. Polaris does NOT require any additional or specific training for the I-24-03 Safety Recall.

Is this a STOP SALE

Yes. This is a STOP SALE. All impacted units, new and used, in dealer inventory cannot be retailed until the repair is complete.

What Dealers CAN Do

1. Can quote new products.
2. Can accept deposits from consumers as a reservation for a future sale.
3. Can utilize PCDX to begin setup and PDI (except for test ride).
4. Can, and should, warranty register impacted product that was delivered to consumers prior to the release of the stop sale to ensure Indian Motorcycle has accurate records and can notify the customer if required.

What Dealers CANNOT Do

1. Cannot complete a sale.
2. Cannot deliver impacted products to consumers.
3. Cannot allow a consumer to purchase and take an affected product.
4. Cannot warranty register an affected vehicle (unless delivered to the consumer prior to the release of the stop sale).
5. Cannot hold customers' vehicles in service against their will.

What parts are required to update the vehicles affected by this recall?

No parts are required for I-24-03. This is a software update.

Will performing the ABS Module update affect other controller's software such as the ECM or VCM?

No, the ABS module software update will only update the ABS module if that is all that is selected. It is suggested that you update all controllers with the most current software if available.

What should dealers do with service parts in dealer inventory?

Nothing. Dealer service parts are not affected by I-24-03.

Are there special tools required to complete this Safety Recall?

One special tool, ABS Reflash Harness is required for I-24-03-AB to update the ABS software on Challenger or Pursuit models. This tool was shipped to dealers on the release of the Safety Recall. If the tool is lost, the dealer will need to purchase a replacement by ordering PN 2416838.

Will dealers be paid for performing this Safety Recall?

Yes. Dealers will be reimbursed for the cost to perform the recall.

Can I allow demos on vehicles that haven't had I-24-03 performed?

While this is **not** a STOP RIDE it is **highly** recommended that dealers complete the repair prior to operating an affected vehicle.

How does a dealer warranty register a unit that a customer has paid for and taken delivery of PRIOR to the STOP SALE announcement?

The warranty registration capability is disabled for all units affected by the stop sale. If the unit has not been paid for, or if the unit has not yet been delivered to the customer, you should retrieve or hold the unit until repairs have been completed.

In the event that a warranty registration must be completed, please submit an Ask Polaris case using Sales Question > Wholegoods Question and include the following:

- Completed PCDX Customer Information and Customer Delivery form
- Sales invoices: Paper & DMS
- Copies of form of payment document or payment check
- Copies of purchaser's identification
- Copies of the state registration forms unless the registration was VERY recent, and this has not yet been obtained
- The promo selection for the unit (Program Number, Rebate Amount, Promotional Financing, etc.)
- Salesperson's First Name and Last Name and My Polaris Rewards Username to award points or spiffs.

* Warranty Registrations that are received and processed by Indian Motorcycle more than three (3) days after the date of the retail delivery of the unit to the customer will not qualify for any financial incentives and may be assessed a \$300 late fee.

If you have questions that are not addressed in this document or in the recall, contact Indian Motorcycle Service through Ask Polaris or by phone at 800-330-9407.



IMPORTANT SAFETY RECALL

Indian Motorcycle
Company
P.O. Box 47700
Medina, MN 55340-9960

This notice applies to your vehicle
Recall Campaign: **24V-069**
Subject: **2019-2020 and 2022 FTR, 2020-2022 Challenger,
2022 Pursuit**
ANTI-LOCK BRAKE (ABS) SOFTWARE UPDATE
PLEASE READ IMMEDIATELY

VIN: I-24-03
First Name Last Name
Address
City, State ZIP

Dear Indian Motorcycle Owner,

This notice is sent to you in accordance with the National Traffic and Motor Vehicle Safety Act. Indian Motorcycle has decided that a defect which relates to motor vehicle safety exists in Model Year 2019-2020 and 2022 FTR, Model Year 2020-2022 Challenger, and Model Year 2022 Pursuit motorcycles equipped with a specific Anti-Lock Brake System (ABS) module. Our records show you have purchased an affected vehicle.

The reason for this notice:

Your motorcycle may experience inadvertent brake light illumination, which increases the risk of a crash and serious injury. This can occur without rider input during certain limited riding conditions when a momentary loss of wheel contact with the ground occurs.

What you should do:

Contact your authorized Indian Motorcycle dealer to schedule an appointment to have the repairs performed. Do not attempt repairs yourself. Repairs must be done only by an authorized Indian Motorcycle dealer. This repair should take approximately 30 minutes. When making contact with your dealer, discuss parts availability, their schedule and how long they will need to keep your vehicle. This work will be performed by your dealer at no cost to you.

What your dealership will do:

To address this concern, Indian Motorcycle has authorized your dealer to update the ABS module with new software.

This notice was mailed to you according to our most current registration information. If you no longer own this vehicle, or if some of the contact information in this notice is incorrect, please contact your dealer to complete a transfer of ownership. Federal law requires that any vehicle lessor receiving this notice must forward a copy of this notice to the lessee within 10 working days after the day on which the notice is received.

If you need assistance contacting or locating an Indian Motorcycle dealer, or if you have questions your Indian Motorcycle dealer is not able to address, contact our Indian Motorcycle Owner Connections Department at 1-877-204-3697, scan the QR code, or go to <https://www.polaris.com/en-us/help-center/>.



If you previously paid for repair(s) to your vehicle for this specific condition prior to receiving this letter, you may be eligible to receive reimbursement for the cost of obtaining a pre-notification remedy of the problem associated with this recall. For more information regarding obtaining reimbursement please contact your Indian Motorcycle Dealer or Indian Motorcycle Owner Connections Department using the contact information above.

If you believe that Indian Motorcycle has failed to remedy this defect without charge or is unable to do so within a reasonable time, you may submit a complaint to the Administrator, National Highway Traffic Safety Administration, 1200 New Jersey Avenue SE., Washington, D.C. 20590; or call the toll-free Vehicle Safety Hotline at 1-888-327-4236 (TTY: 1-800-424-9153); or on the web go to www.nhtsa.gov.

We apologize for this inconvenience and assure you that we are committed to customer satisfaction and providing world-class products for riders to enjoy.

Sincerely,

Indian Motorcycle Company

For the latest updates to this safety recall, or to check if your vehicle is part of another safety recall, scan the QR code, or go to www.polaris.com/en-us/on-road-recalls/.





IMPORTANT SAFETY RECALL

Indian Motorcycle
Company
P.O. Box 47700
Medina, MN 55340-9960

This notice applies to your vehicle
Recall Campaign: **2024-752**
Subject: **2019-2020 and 2022 FTR, 2020-2022 Challenger,
2022 Pursuit**
ANTI-LOCK BRAKE (ABS) SOFTWARE UPDATE
PLEASE READ IMMEDIATELY

VIN: I-24-03
First Name Last Name
Address
City, State ZIP

Dear Indian Motorcycle Owner,

This notice is sent to you in accordance with the requirements of the *Motor Vehicle Safety Act*. This is to inform you that your vehicle may contain a defect that could affect the safety of a person. Indian Motorcycle has decided that a defect which relates to motor vehicle safety exists in Model Year 2019-2020 and 2022 FTR, Model Year 2020-2022 Challenger, and Model Year 2022 Pursuit motorcycles equipped with a specific Anti-Lock Brake System (ABS) module. Our records show you have purchased an affected vehicle.

The reason for this notice:

Your motorcycle may experience inadvertent brake light illumination, which increases the risk of a crash and serious injury. This can occur without rider input during certain limited riding conditions when a momentary loss of wheel contact with the ground occurs.

What you should do:

Contact your authorized Indian Motorcycle dealer to schedule an appointment to have the repairs performed. Do not attempt repairs yourself. Repairs must be done only by an authorized Indian Motorcycle dealer. This repair should take approximately 30 minutes. When making contact with your dealer, discuss parts availability, their schedule and how long they will need to keep your vehicle. This work will be performed by your dealer at no cost to you.

What your dealership will do:

To address this concern, Indian Motorcycle has authorized your dealer to update the ABS module with new software.

If you need assistance contacting or locating an Indian Motorcycle dealer, or if you have questions your Indian Motorcycle dealer is not able to address, contact our Indian Motorcycle Owner Connections Department at 1-877-204-3697, scan the QR code, or go to <https://www.polaris.com/en-ca/help-center/>.



If after contacting your dealer and/or Indian Motorcycle customer care helpline, you have additional questions in regards to this recall, you may contact Transport Canada - Road Safety, 80 rue Noël, Gatineau, Quebec J8Z 0A1 or call 1-800-333-0510

We apologize for this inconvenience and assure you that we are committed to customer satisfaction and providing world-class products for riders to enjoy.

Sincerely,

Indian Motorcycle Company

For the latest updates to this safety recall, or to check if your vehicle is part of another safety recall, scan the QR code, or go to www.polaris.com/en-ca/on-road-recalls/.



This notice was mailed to you according to our most current registration information. If you no longer own this vehicle, or if some of the contact information in this notice is incorrect, please contact your dealer to complete a transfer of ownership. Federal law requires that any vehicle lessor receiving this notice must forward a copy of this notice to the lessee within 10 working days after the day on which the notice is received.

Polaris Industries Ltd.
Consumer Service Department
50 Prairie Way
Winnipeg, MB, CA R2J - 3J8

Ref: I2403