

**Safety Recall: 2020–22 Accord Seat Weight Sensor (DTC U3000-49)**

Supersedes 24-016, dated March 19, 2024, to revise the information highlighted in **yellow**.

**REVISION SUMMARY**

Under **WARRANTY CLAIM INFORMATION**, a new table entry was added.

**AFFECTED VEHICLES**

Year	Model	Trim Level	VIN Range
2020–22	Accord	ALL	Check the iN VIN status for eligibility.
2020–21	Accord Hybrid	ALL	Check the iN VIN status for eligibility.

**BACKGROUND**

Affected vehicles may be equipped with seat weight sensors that are not built to proper specifications. Improperly built sensors could lead to cracking and/or a short circuit of the sensor, resulting in the illumination of the SRS warning light and the passenger airbag indicator remaining OFF. In certain collisions, these seat weight sensors may cause improper deployment of the front passenger airbags, increasing the risk of injury.

**CUSTOMER NOTIFICATION**

Owners of affected vehicles will be sent a notification of this safety recall.

Do an iN VIN status inquiry to verify eligibility.

Some vehicles affected by this campaign may be in your new or used vehicle inventory.

Failure to repair a vehicle subject to a recall or campaign may subject your dealership to claims or lawsuits from the customer or anyone else harmed as a result of such failure. To see if a vehicle in inventory is affected by this safety recall, do a VIN status inquiry before selling it.

**CORRECTIVE ACTION**

- If the SRS warning light is not illuminated, refer to campaign notice 24-050.
- If the SRS warning light is illuminated, follow the inspection procedure outlined in this bulletin.

**PARTS INFORMATION**

Due to a limited supply of controlled parts, they require prior approval before shipping. This will be determined by the INSPECTION PROCEDURE, follow the steps provided by the QR code.

**CUSTOMER INFORMATION:** The information in this bulletin is intended for use only by skilled technicians who have the proper tools, equipment, and training to correctly and safely maintain your vehicle. These procedures should not be attempted by “do-it-yourselfers,” and you should not assume this bulletin applies to your vehicle, or that your vehicle has the condition described. To determine whether this information applies, contact an authorized Honda automobile dealer.

## WARRANTY CLAIM INFORMATION

**NOTE: If the INSPECTION PROCEDURE determines this Service Bulletin doesn't apply, use template C to submit a warranty claim for the inspection.**

Operation Number	Description	Flat Rate Time	Defect Code	Symptom Code	Template ID	Failed Part Number
7491E3	Replace power seat slide (includes inspect and DTC check)	1.3 hr	6XW00	RHL00	A24016A	81201-TBA-A61
8521K5	Replace manual seat frame (includes inspect and DTC check)	1.5 hr	6XW00	RHL00	A24016B	81126-TLA-C01
<b>7495A1</b>	<b>For stored DTCs other than DTC U3000-49 and/or inspection determines this Service Bulletin does not apply.</b>	<b>0.3 hr</b>	<b>6XZ00</b>	<b>KIT00</b>	<b>A24016C</b>	<b>81136-T20-A61</b>

Skill Level: Repair Technician

## INSPECTION PROCEDURE

1. Check for the SRS airbag light on the dash.
2. If the airbag light is on, connect the HDS to the vehicle. Do an All DTC check.
3. If DTC U3000-49 is present, continue to step 4.  
If DTCs other than U3000-49 are found, this service bulletin does not apply. Continue with normal troubleshooting.
4. Remove the adjustable head restraint.
5. Move the seat all the way forward and remove the rear mounting bolts.

### REAR SIDE

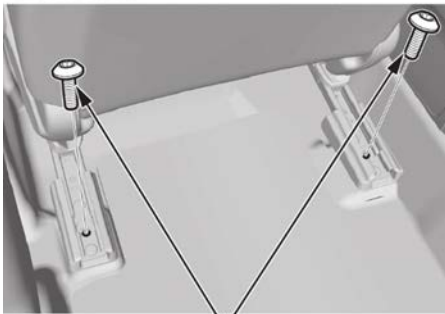

**BOLTS**  
43 N·m  
(32 lb-ft)

6. Move the seat all the way rearward and remove the front mounting bolts.

**FRONT SIDE**

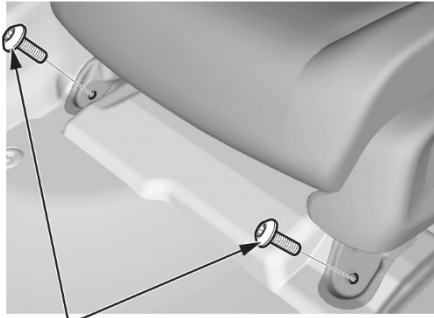

**BOLTS**  
43 N·m  
(32 lb-ft)

7. Disconnect the negative terminal from the 12-volt battery.

**1.5L ENGINE**

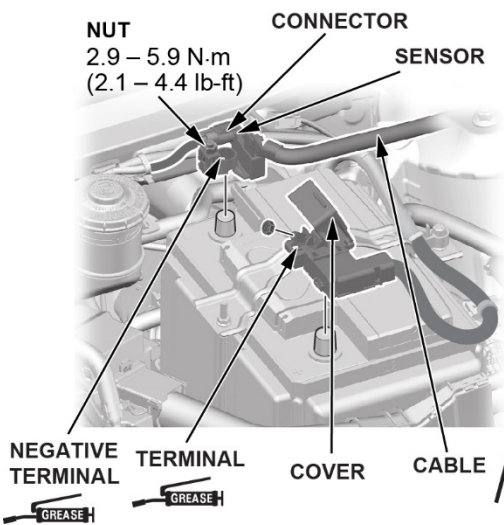

**2.0L ENGINE**

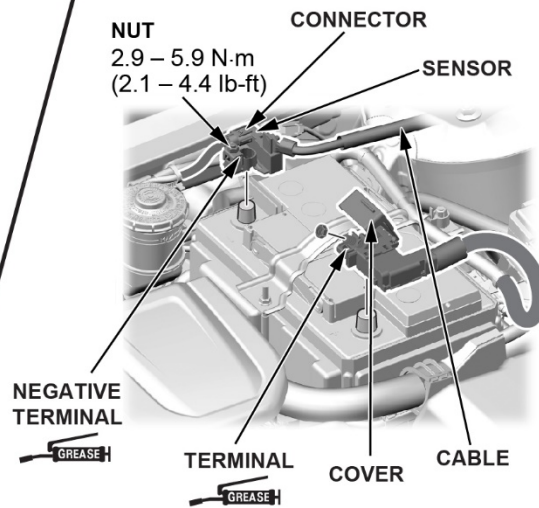

8. Tilt the seat back and disconnect the seat weight sensor connectors from the seat harness.
9. Connect the negative terminal of the 12-volt battery.

10. With the seat weight sensors disconnected, clear the DTC and do an All DTC check.

NOTE: Other new DTCs may be stored due to the seat weight sensors being unplugged. Disregard these new DTCs at this time.

- If DTC U3000-49 (Internal Failure of the SRS Unit) does not return, scan the QR code with a capable device and complete the form.

NOTE:

- This form must be filled out before parts can be ordered.
- If you can't scan the QR code, [\(Click HERE\)](#).



- If DTC U3000-49 does return, this service bulletin does not apply. Reconnect the SWS connectors and continue with normal troubleshooting.

## REPAIR PROCEDURE MANUAL SEAT

NOTE: For Power Seats, See Page 11.

1. Disconnect the negative terminal of the 12-volt battery.

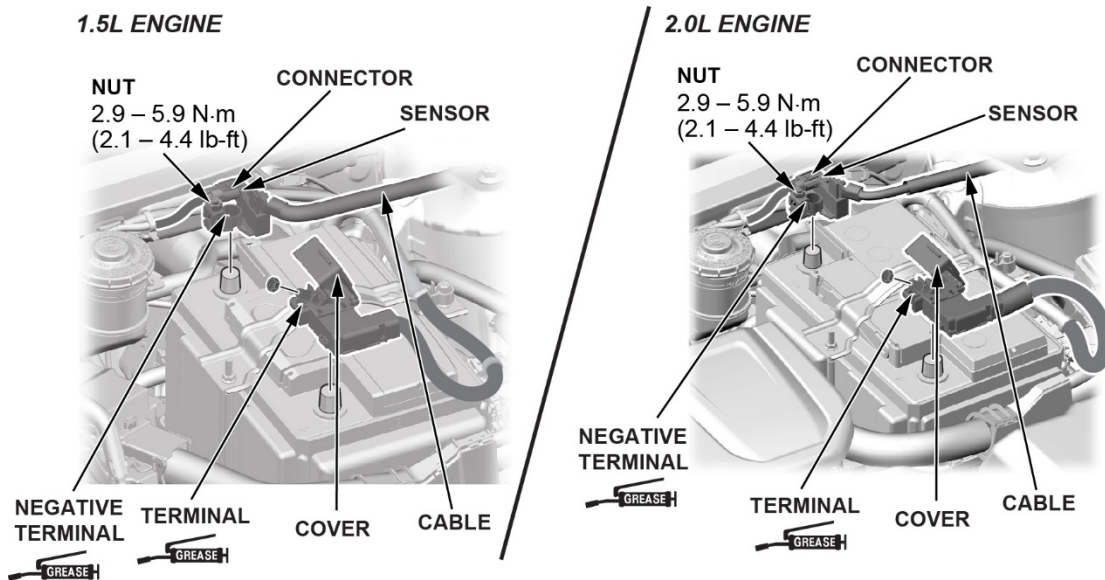

- Lift up the front seat, then disconnect the three remaining connectors and detach the harness clip.

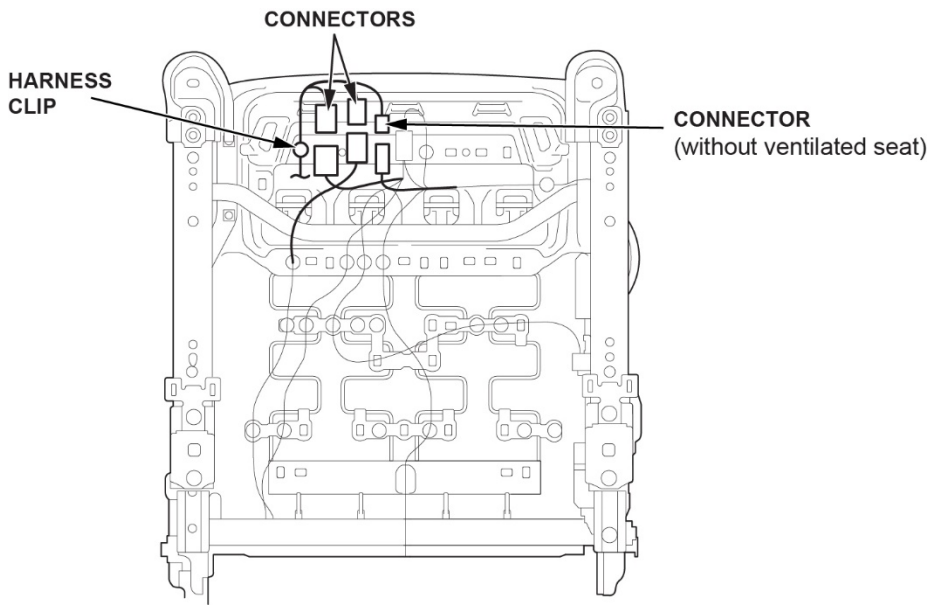

- With the help of an assistant, carefully remove the front seat through the front door opening, then, place the seat on a suitable area to work.
- Take a picture of the harness arrangement underneath the seat, then disconnect any remaining connectors and release the harness clips from the seat cushion frame.

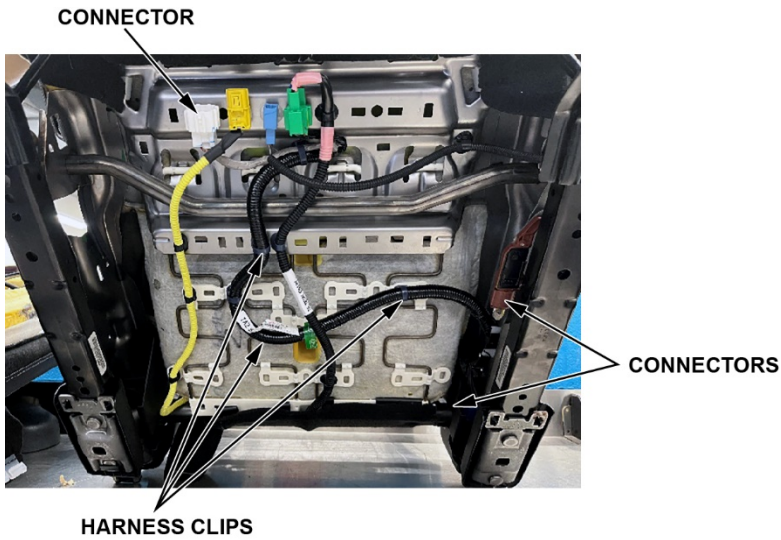

- Remove the front seat rear foot cover.

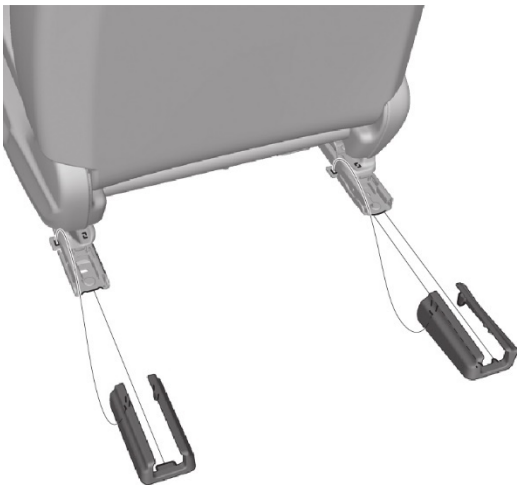

6. Remove the upper rail inner cover.

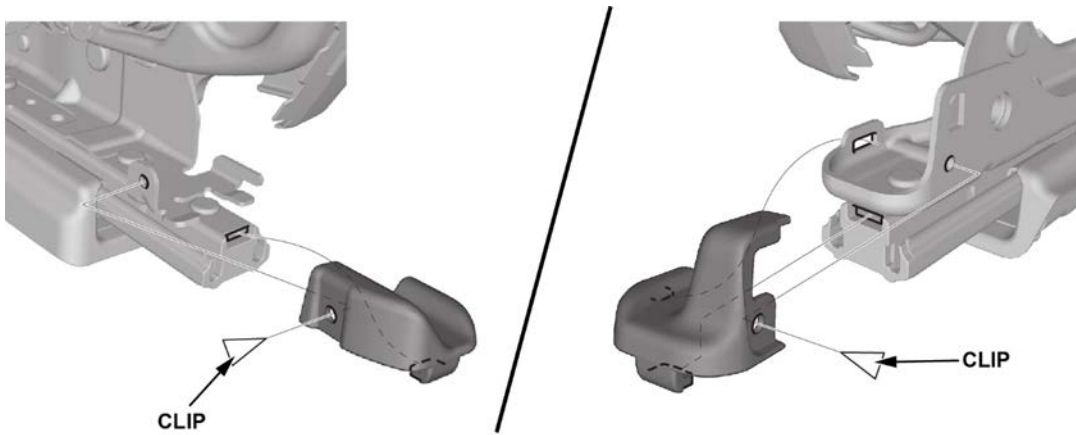

7. Release the hook strip, unzip the seat back cover, then remove the seat back cover pad.

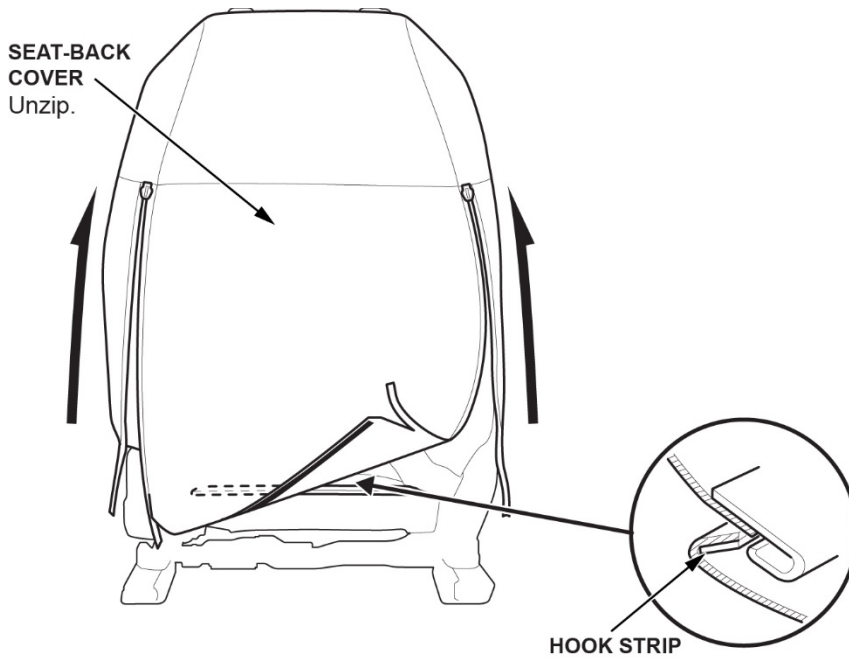

8. Release the hook strips, then remove the harness holder.

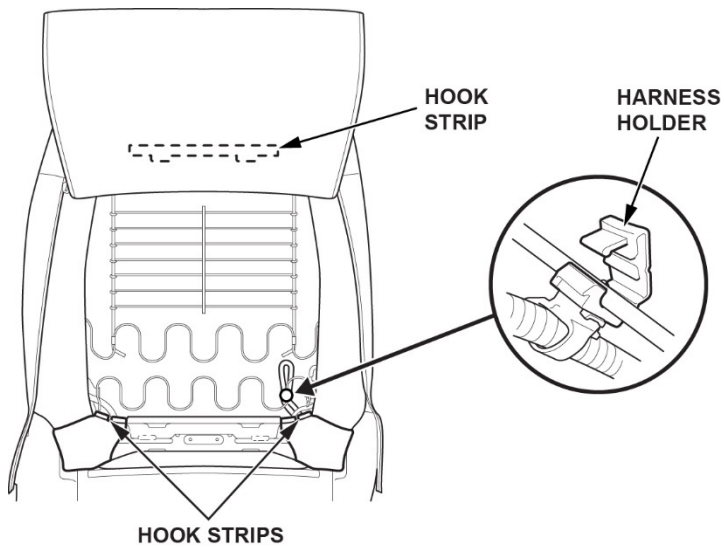

9. Remove the head restraint guides.

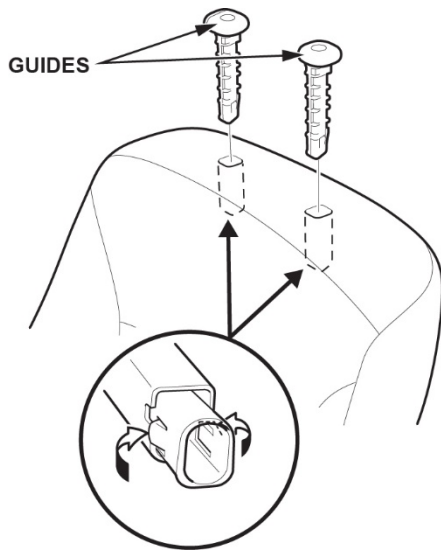

10. If equipped: Detach the clips, disconnect the blower motor duct, and then remove the seat back cover pad.

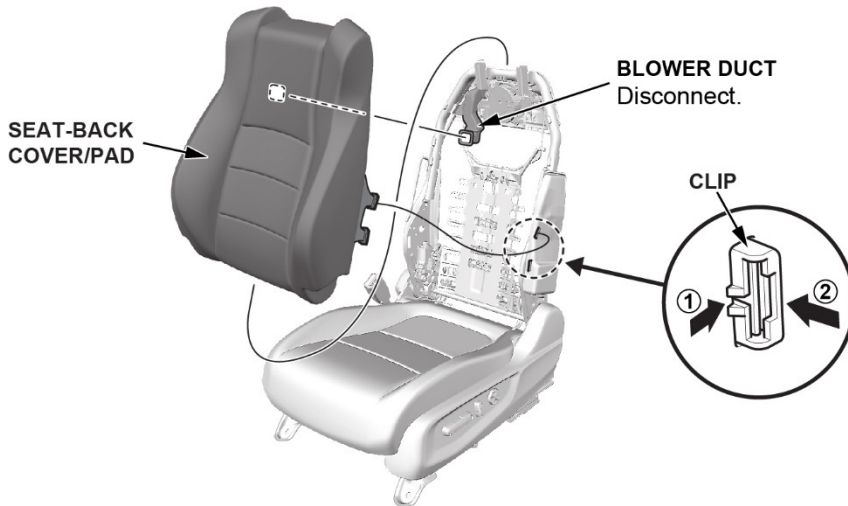

11. Remove the front seat recline knob and the front seat outer recline cover.

*PASSENGER'S SIDE*

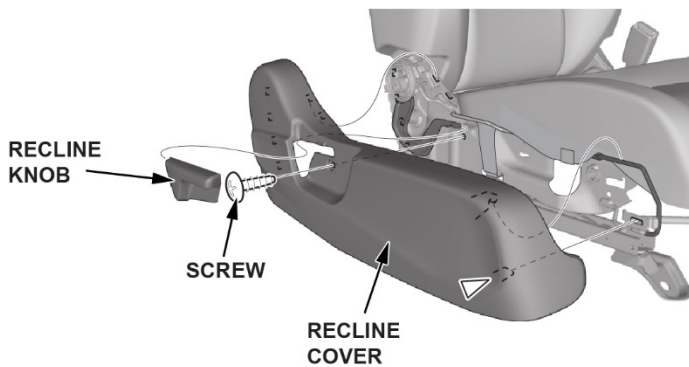

12. Remove the front seat inner recline cover.

**PASSENGER'S SEAT**

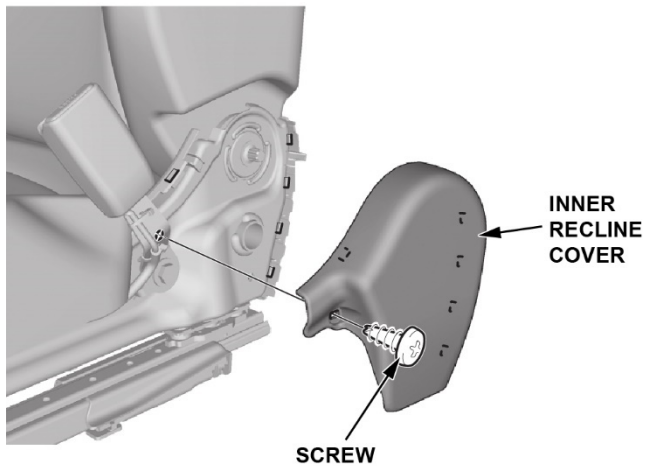

13. Release the hook strips.

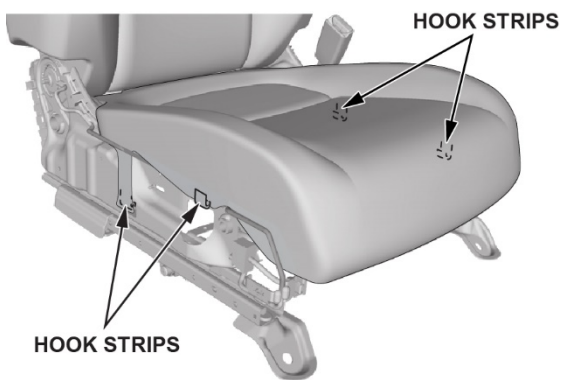

14. Remove the seat cushion cover.





15. Remove the clips and the mounting nuts. Pull the harness from the clearance of the seat frame and remove the side airbag.

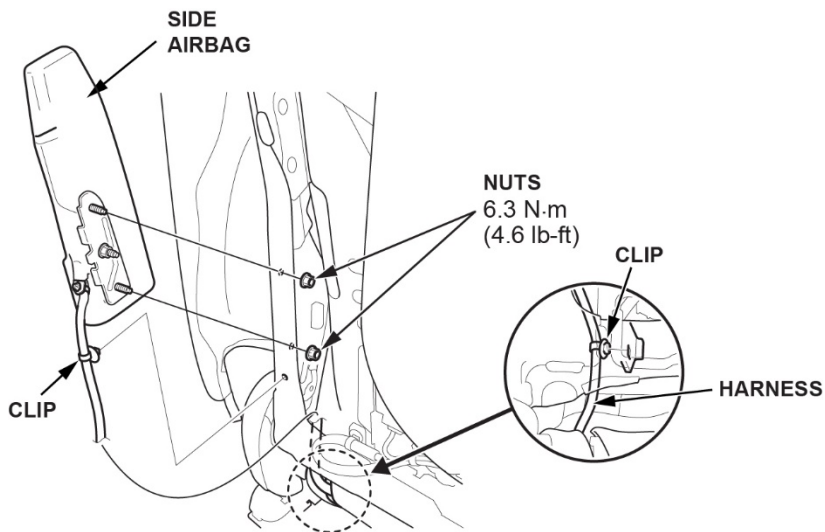

16. Remove the front seat belt buckle.

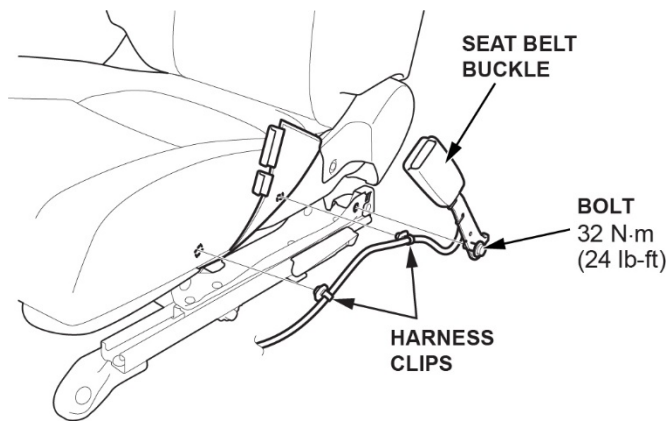

17. Remove the recline inner and outer cover.

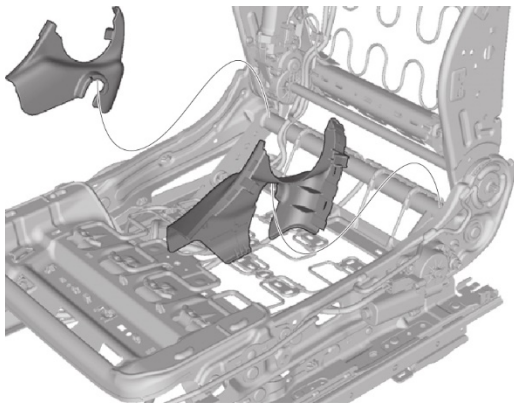

18. Remove the front seat side airbag holder.

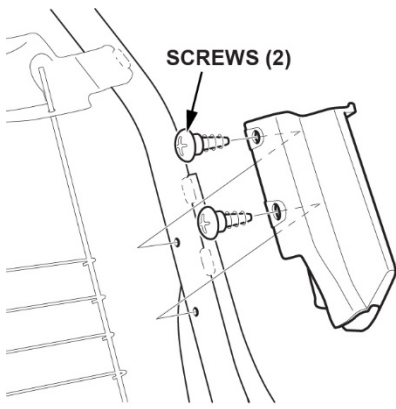

19. Connect the negative terminal of the 12-volt battery:

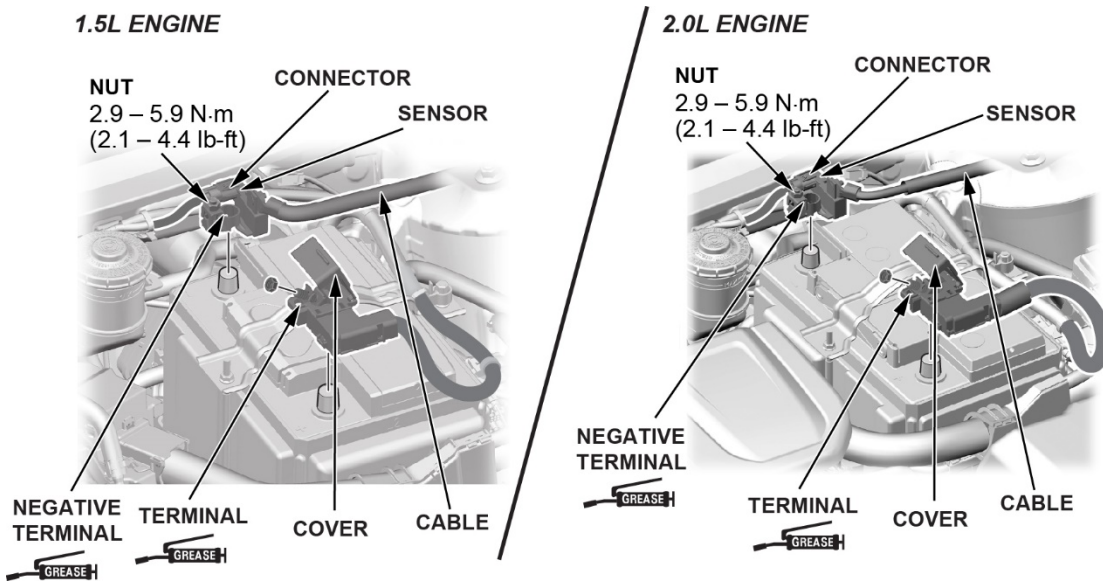

20. Transfer all removed parts onto the new seat frame in the reverse order of removal.

21. Install the bolts to the passenger's seat, and tighten the bolts by hand first, then tighten them to the specified torque in the sequence shown.

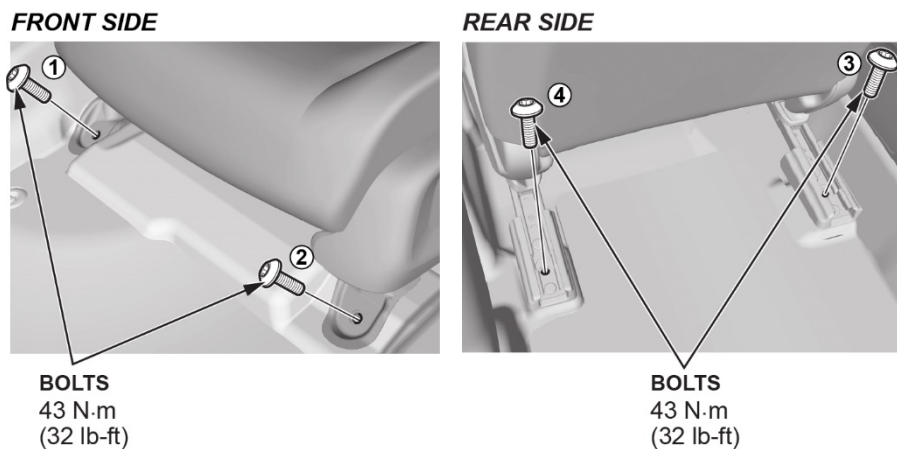

22. Do the seat weight sensor initialization ([Click Here](#)).

23. Do the front weight sensor operation check ([Click Here](#)).

24. Confirm the SRS Operation: Turn the vehicle to the ON mode, and check that the SRS indicator comes on for about 6 seconds and then goes off.

25. Do the steering neutral position learn procedure ([Click Here](#)).

## REPAIR PROCEDURE POWER SEAT

1. Disconnect the negative cable of the 12-volt battery.

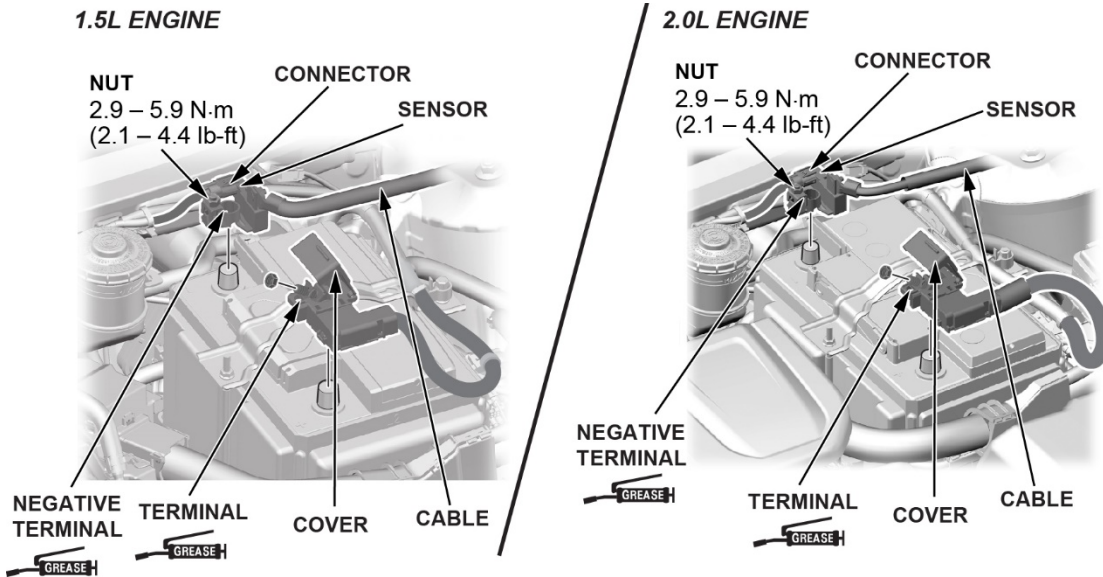

2. Lift the seat, remove the harness clip, and disconnect the connectors.

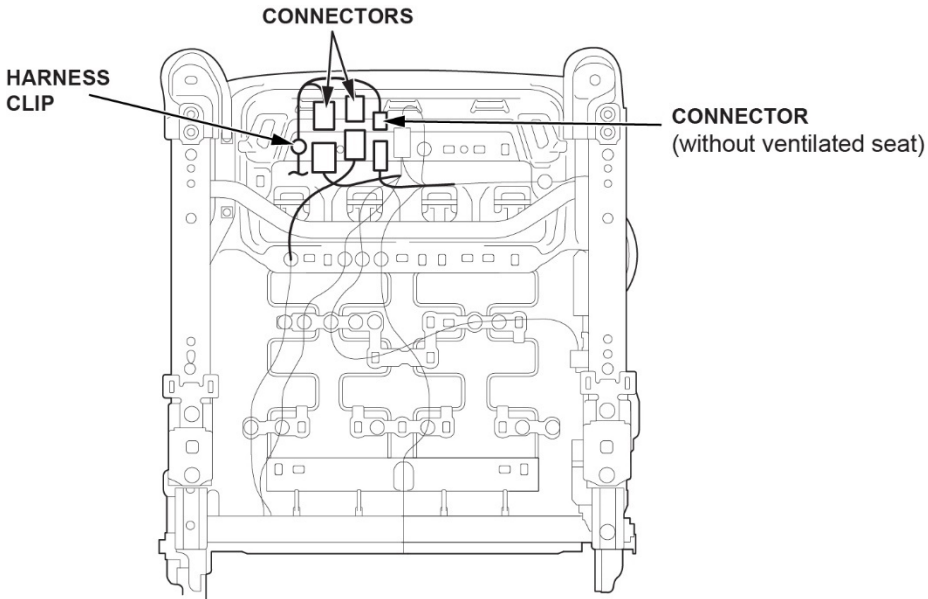

3. With the help of an assistant, carefully remove the front passenger's seat through the front door and place it on a clean, flat surface.

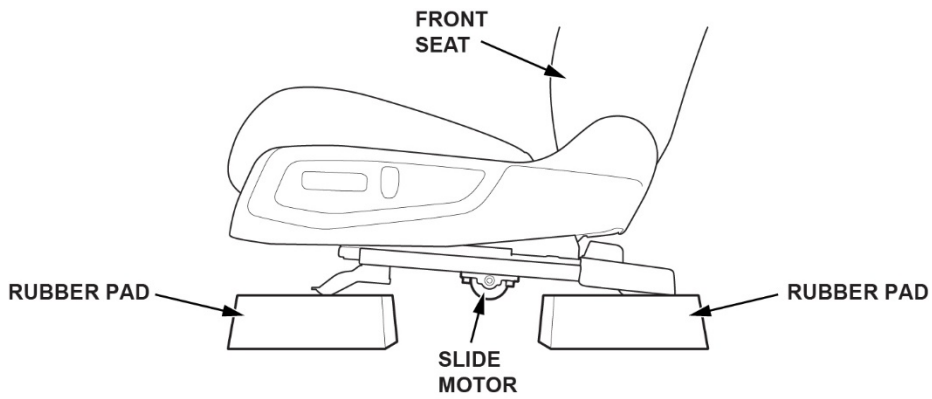

**NOTE:**

- Use the rubber pads to support the front seat.
  - Take care not to damage the side motor.
4. Take a picture of the harness arrangement underneath the seat, then disconnect the connector on the front passenger seat power motor.

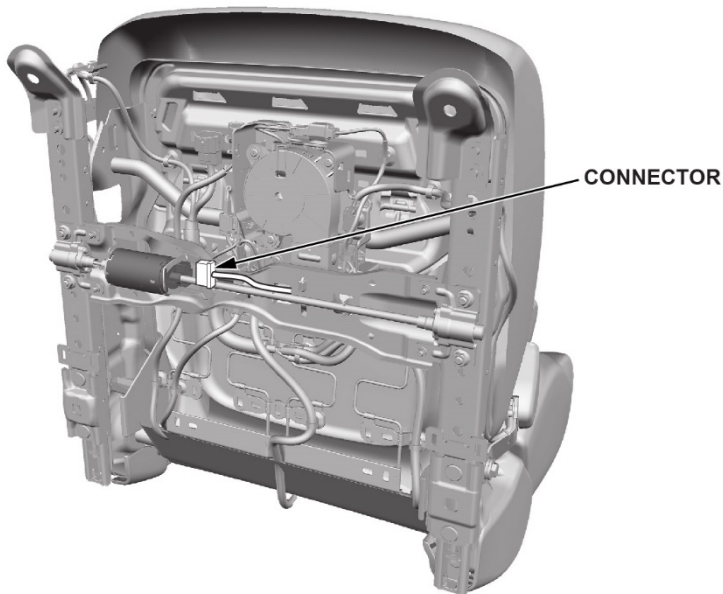

5. Remove the power seat front seat recline covers.

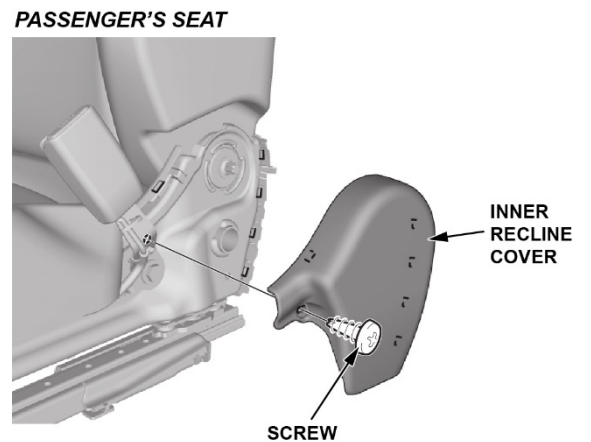
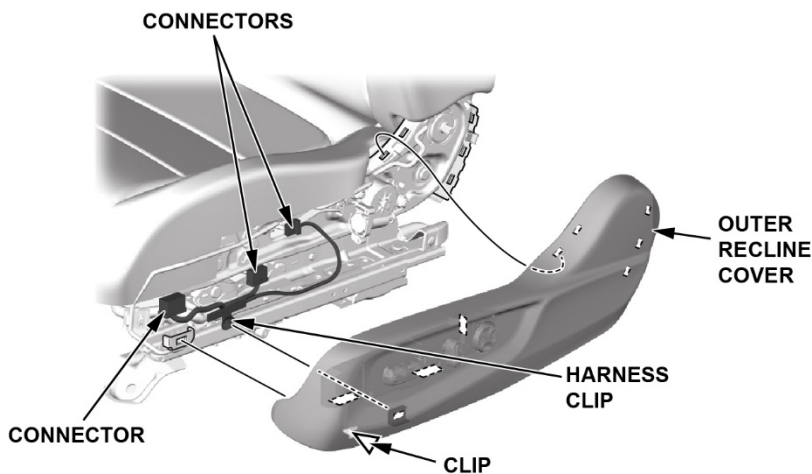

6. Disconnect the connectors.

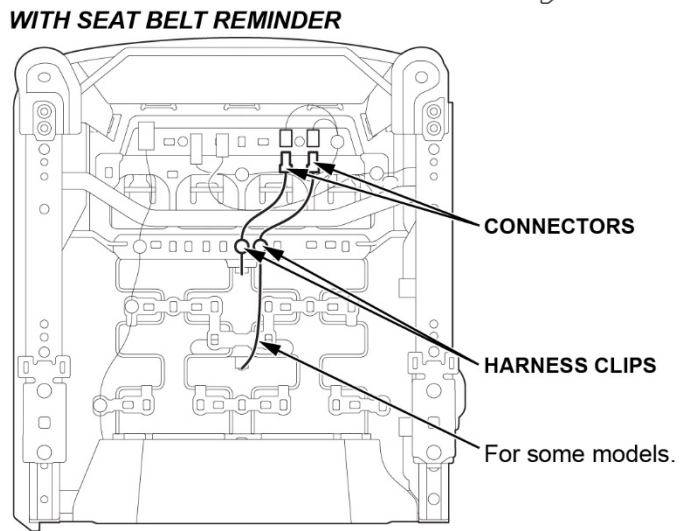
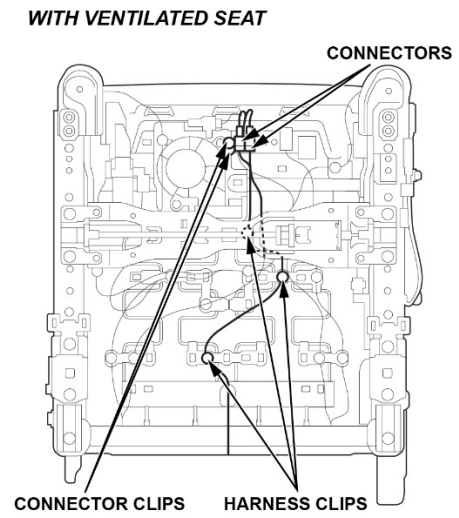
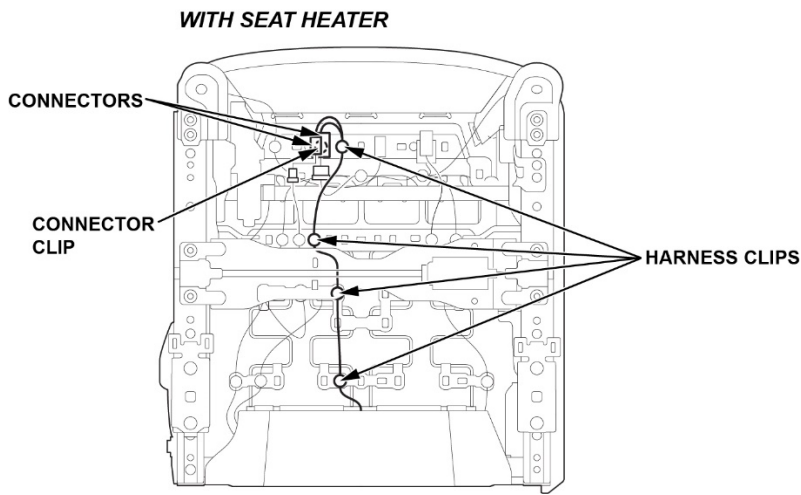

7. Detach the harness clips and the connector clip.

8. Release the hook strips.

**WITH VENTILATED SEAT**

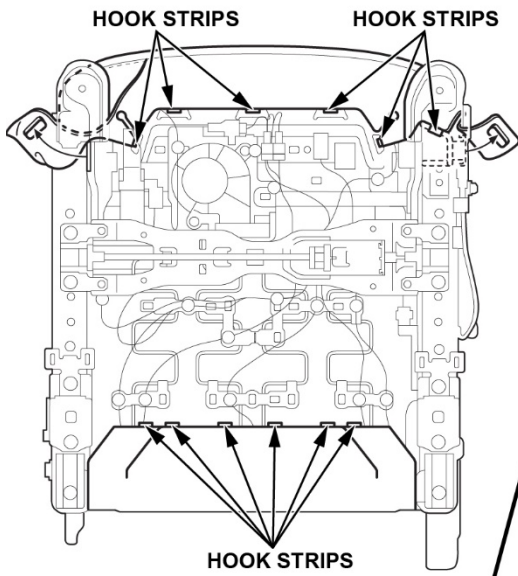

**WITHOUT VENTILATED SEAT**

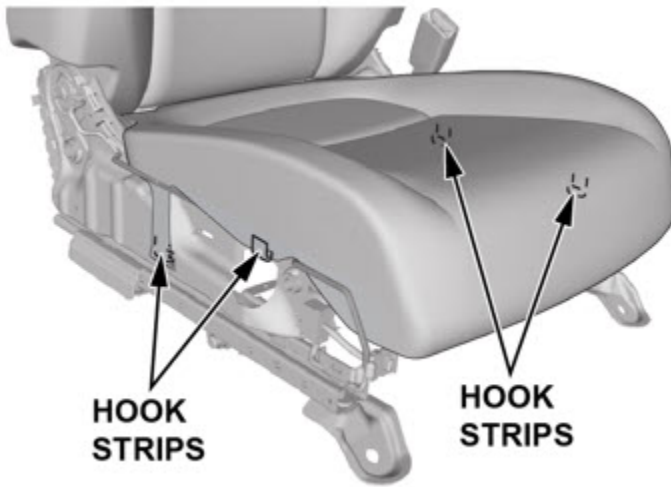
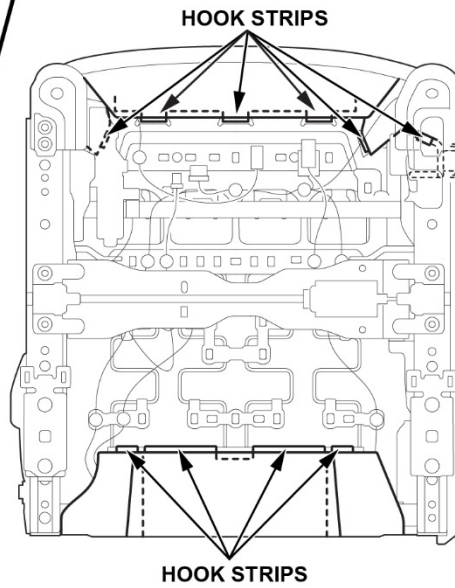

9. With ventilated seat: Disconnect the duct.

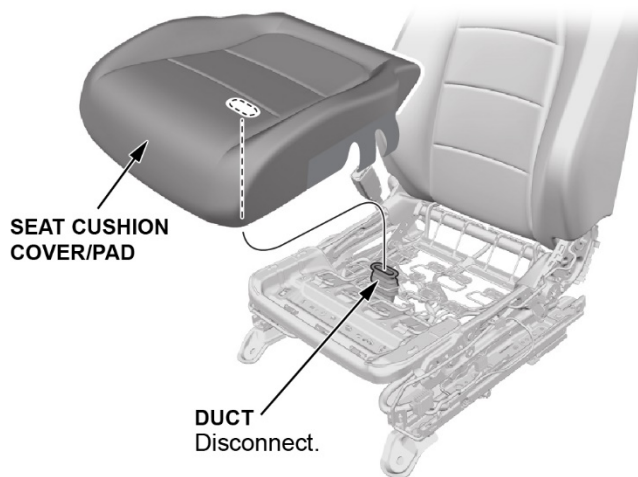

10. Remove the seat rails from the seat.

NOTE: Take a picture of all four seat frame nuts, bushings, and collars for reference.

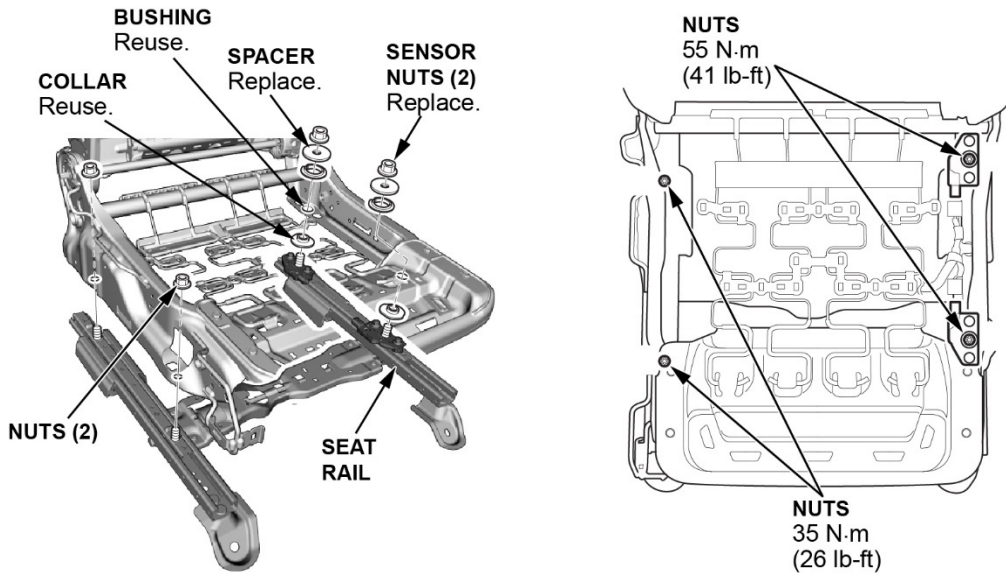

11. Install the new front passenger's seat rail weight sensors as an assembly to the seat frame, and loosely tighten the new weight sensor nuts and mounting nuts.

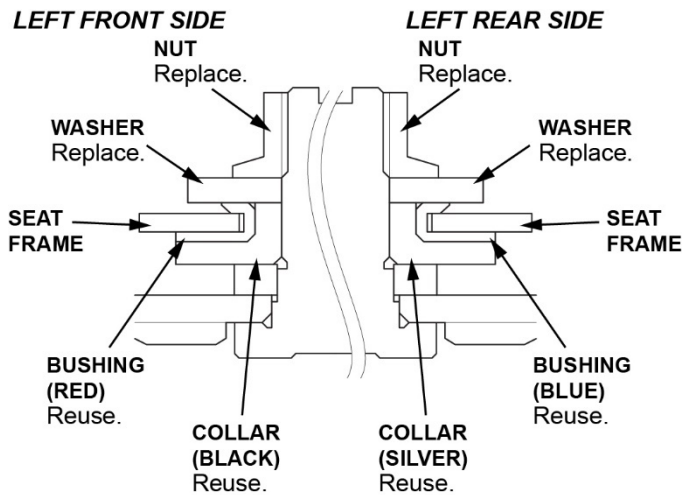

NOTE: The bushings and collars can be identified by their color. Make sure to reinstall the bushings and collars as shown above.

12. Install all parts in the reverse order of removal.

13. Install the bolts to the passenger's seat and tighten the bolts by hand first, then tighten them to the specified torque in the sequence shown **43 N-m (32 lb-ft)**.

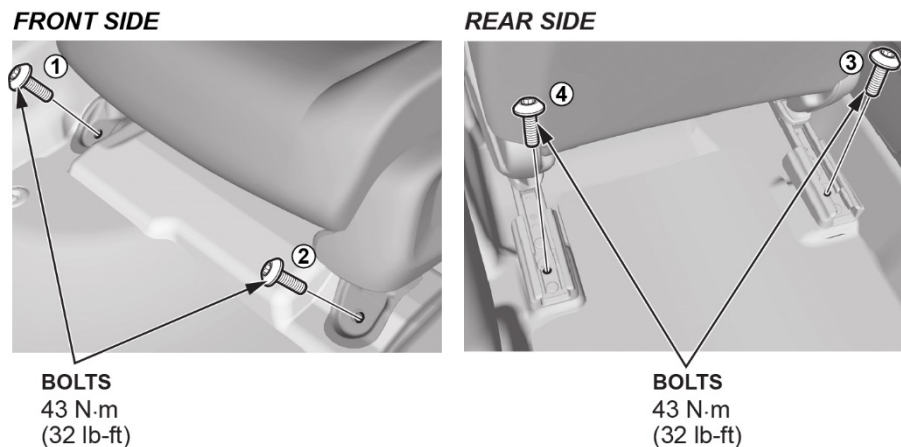

14. Connect the negative terminal of the 12-volt battery.

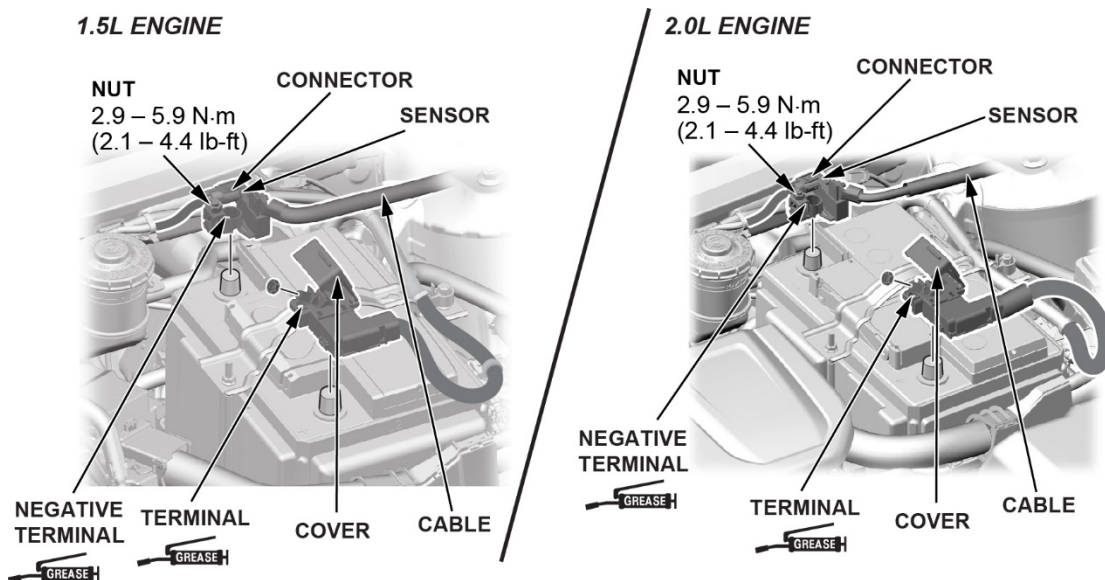

15. Do the seat weight sensor initialization ([Click Here](#)).

16. Do the front weight sensor operation check ([Click Here](#)).

17. Confirm the SRS Operation: Turn the vehicle to the ON mode, and check that the SRS indicator comes on for about **6 seconds** and then goes off.

18. Do the steering neutral position learn procedure ([Click Here](#)).