

July 17, 2024

Version 2

Safety Recall: 2020-21 CR-V Seat Weight Sensor (DTC U3000-49)Supersedes 24-021, dated March 19, 2024, to revise the information highlighted in **yellow**.**AFFECTED VEHICLES**

Year	Model	Trim Level	VIN Range
2020-21	CR-V	ALL	Check the iN-VIN status for eligibility.
2020-21	CR-V Hybrid	ALL	Check the iN-VIN status for eligibility.

REVISION SUMMARY

Under WARRANTY CLAIM INFORMATION, a new table entry was added.

BACKGROUND

Affected vehicles may be equipped with seat weight sensors that are not built to proper specifications. Improperly built sensors could lead to cracking and/or a short circuit of the sensor, resulting in the illumination of the SRS warning light and the passenger airbag indicator remaining OFF. In certain collisions, these seat weight sensors may cause improper deployment of the front passenger airbags, increasing the risk of injury.

CUSTOMER NOTIFICATION

Owners of affected vehicles will be sent a notification of this safety recall.

Do an iN VIN status inquiry to verify eligibility.

Some vehicles affected by this campaign may be in your new or used vehicle inventory.

Failure to repair a vehicle subject to a recall or campaign may subject your dealership to claims or lawsuits from the customer or anyone else harmed as a result of such failure. To see if a vehicle in inventory is affected by this safety recall, do a VIN status inquiry before selling it.

CORRECTIVE ACTION

- If the SRS warning light is not illuminated, refer to campaign notice 24-050.
- If the SRS warning light is illuminated, follow the inspection procedure outlined in this bulletin.

PARTS INFORMATION

Due to a limited supply of controlled parts, they require prior approval before shipping. This will be determined by the INSPECTION PROCEDURE, follow the steps provided by the QR code.

CUSTOMER INFORMATION: The information in this bulletin is intended for use only by skilled technicians who have the proper tools, equipment, and training to correctly and safely maintain your vehicle. These procedures should not be attempted by "do-it-yourselfers," and you should not assume this bulletin applies to your vehicle, or that your vehicle has the condition described. To determine whether this information applies, contact an authorized Honda automobile dealer.

WARRANTY CLAIM INFORMATION

NOTE: If the INSPECTION PROCEDURE determines this Service Bulletin doesn't apply, use template C to submit a warranty claim for the inspection.

Operation Number	Description	Flat Rate Time	Defect Code	Symptom Code	Template ID	Failed Part Number
7491E3	Replace power seat slide (includes inspect and DTC check)	1.3 hr	6XW00	KHO00	A24021A	81201-TBA-A61
8521K5	Replace manual seat frame (includes inspect and DTC clear)	1.5 hr	6XW00	KHO00	A24021B	81126-TLA-C01
7495A1	For stored DTCs other than DTC U3000-49 and/or inspection determines this Service Bulletin does not apply.	0.3 hr	6XZ00	KIT00	A24021C	81136-T20-A61

Skill Level: Repair Technician

INSPECTION PROCEDURE

1. Check for the SRS warning light on the dash.
2. If the SRS warning light is on, connect the HDS to the vehicle. Do an All DTC check.
3. If DTC U3000-49 is present, continue to step 4.
If DTCs other than U3000-49 are found, this service bulletin does not apply. Continue with normal troubleshooting.
4. Remove the adjustable head restraint.
5. Remove the front seat track covers (if applied) from the passenger seat rail.

FRONT SIDE

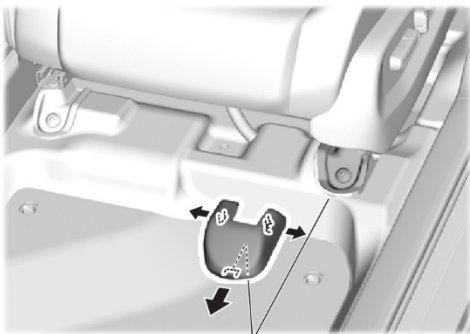

REAR SIDE

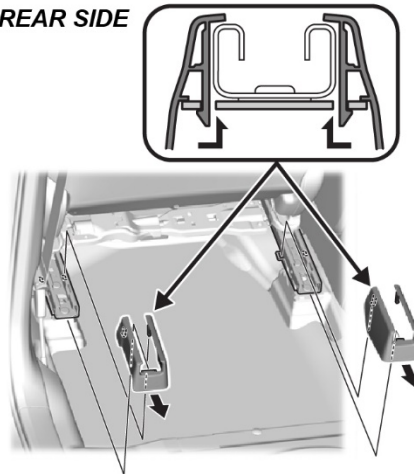

6. Move the seat all the way forward and remove the rear mounting bolts.

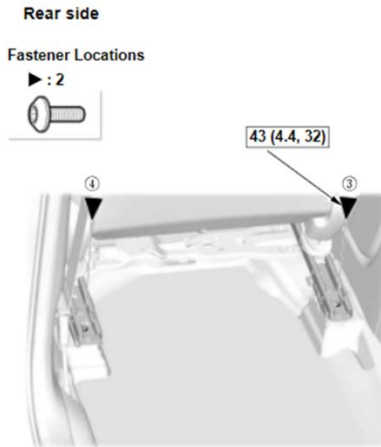

7. Move the seat all the way rearward and remove the front mounting bolts.

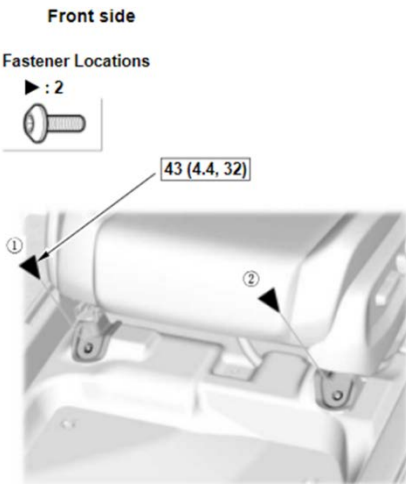

8. Disconnect the negative terminal from the 12-volt battery.

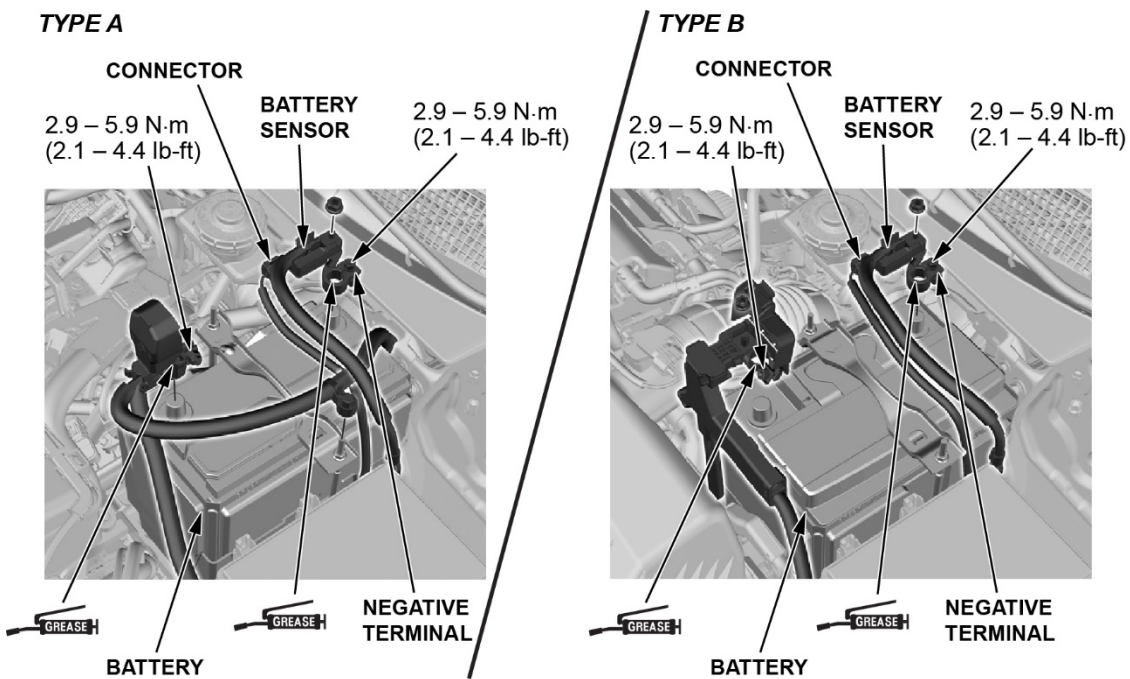

9. Tilt the seat back and disconnect the seat weight sensor connectors from the seat harness.
10. Connect the negative terminal of the 12-volt battery.
11. With the seat weight sensors disconnected, clear the DTC and do an All DTC check.

NOTE: Other new DTCs may be stored due to the seat weight sensors being unplugged. Disregard these new DTCs at this time.

- If DTC U3000-49 (Internal Failure of the SRS Unit) does not return, scan the QR code with a capable device and complete the form.

NOTE:

- This form must be filled out before parts can be ordered.
- If you can't scan the QR code, [\(Click HERE\)](#).



- If DTC U3000-49 does return, this service bulletin does not apply. Reconnect the SWS connectors and continue with normal troubleshooting.

REPAIR PROCEDURE MANUAL SEAT

NOTE: For Power Seats, see page 13.

1. Disconnect the negative terminal of the 12-volt battery.

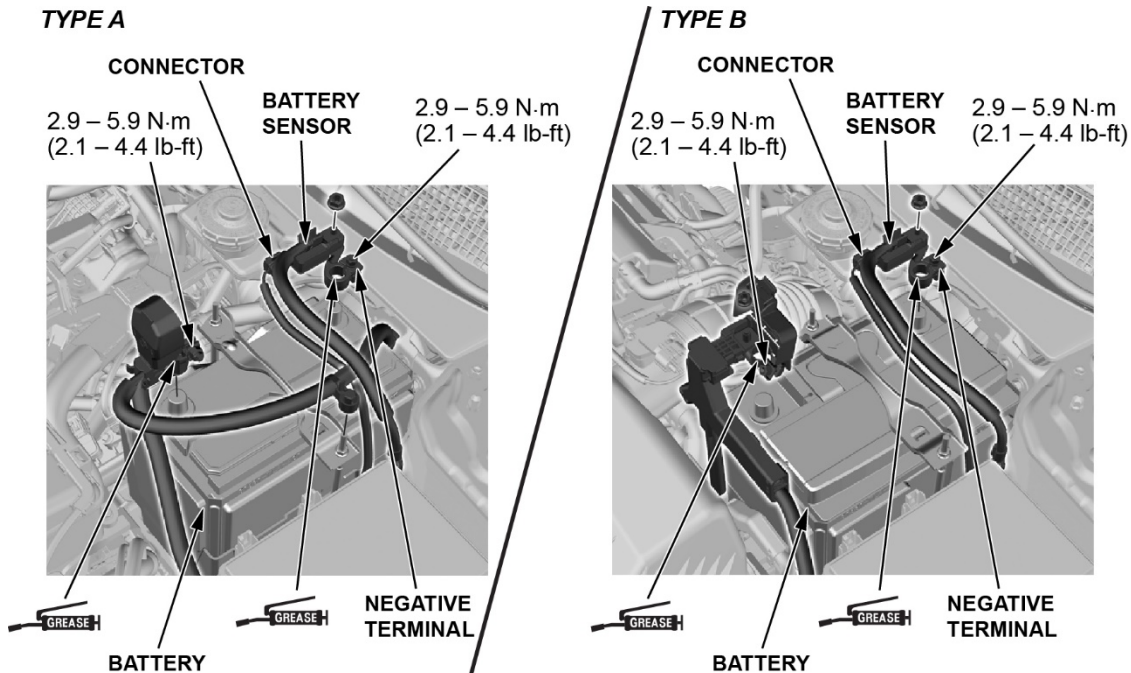

- Depending on the trim, disconnect any remaining connectors from the seat bottom and back.

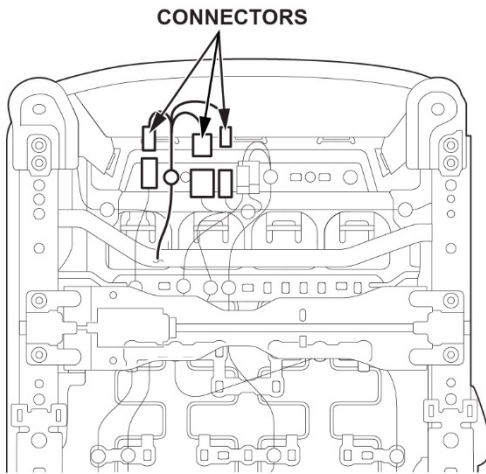

- With the help of an assistant, carefully remove the front seat through the front door opening. Then, place the seat in/on a suitable area to work.
- Release the elastic strap from the seat cushion frame springs.

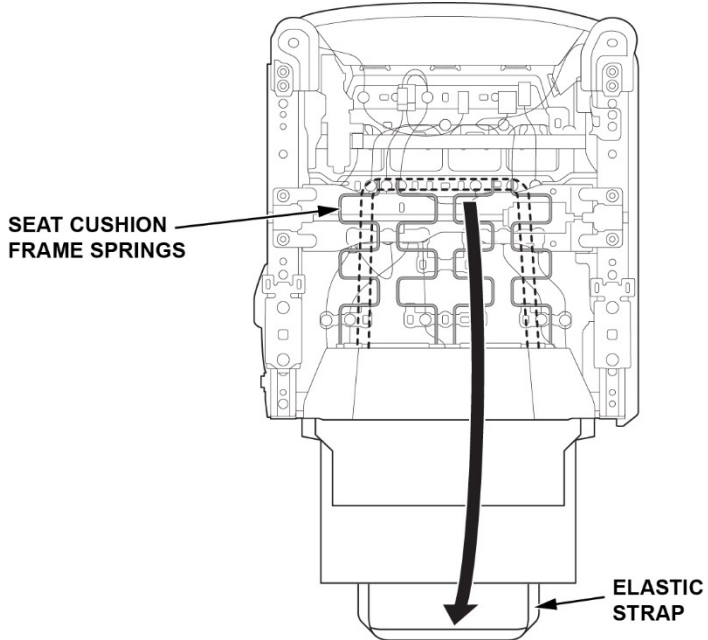

5. Take a picture of the harness arrangement underneath the seat base for harness routing reference, then remove the harness clips, disconnect the connector, and release the hooks on the seat cushion cover.

NOTE: The actual harness layout may vary depending on trim/model options.

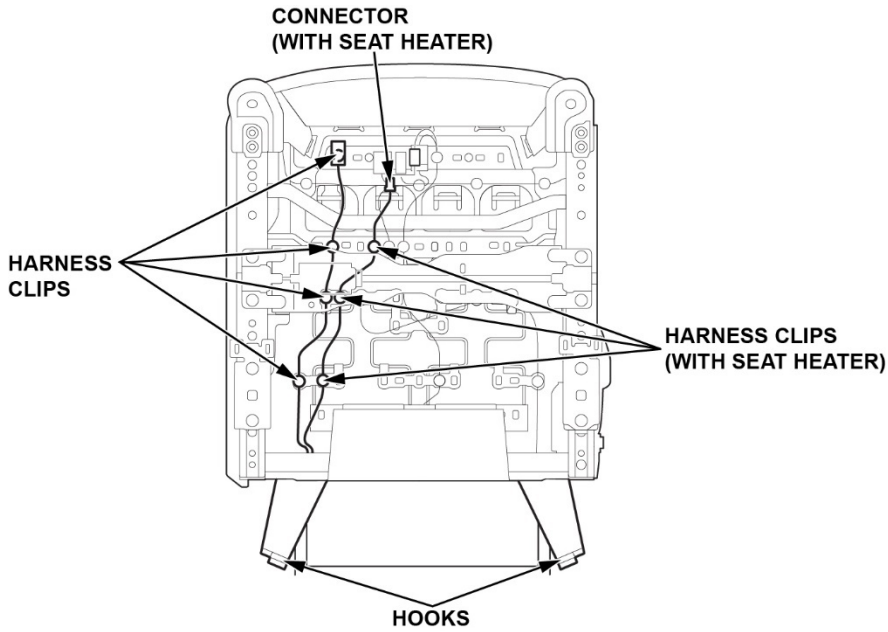

6. Pull out the wire harness and the seat-back cover between the seat cushion pad and the seat frame.

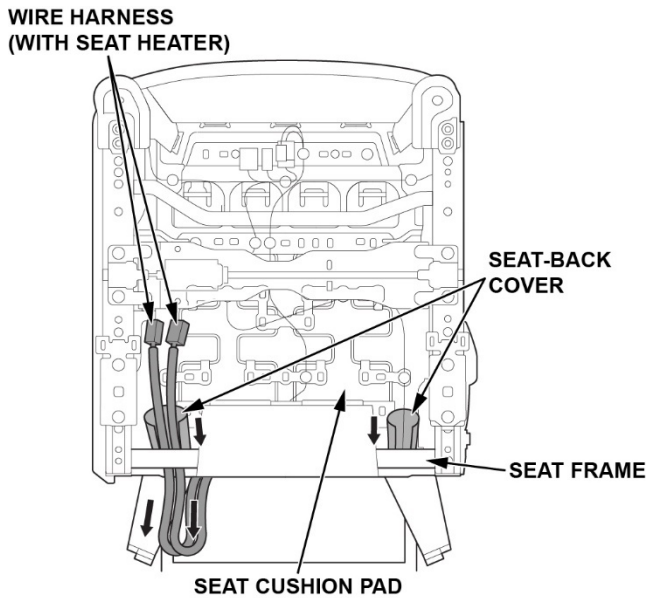

7. Release the hook strip, then unzip the seat-back cover.

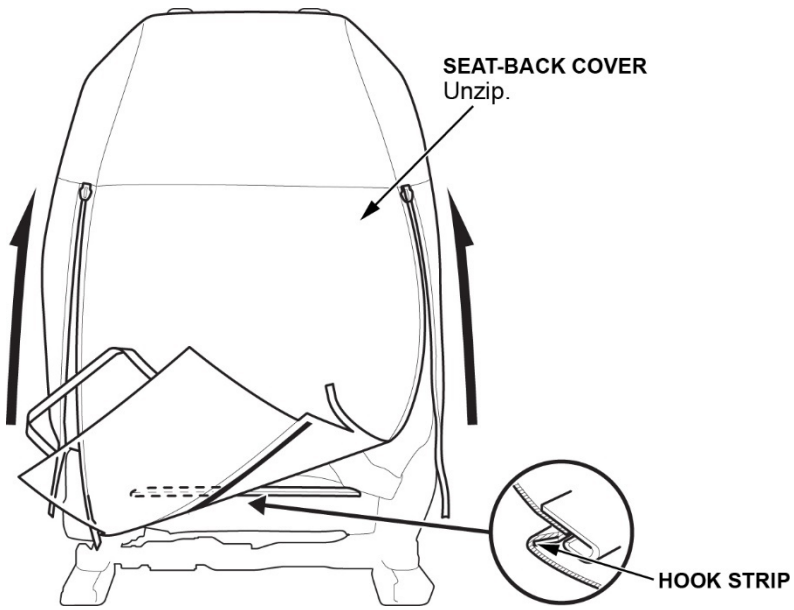

8. Release the hooks.

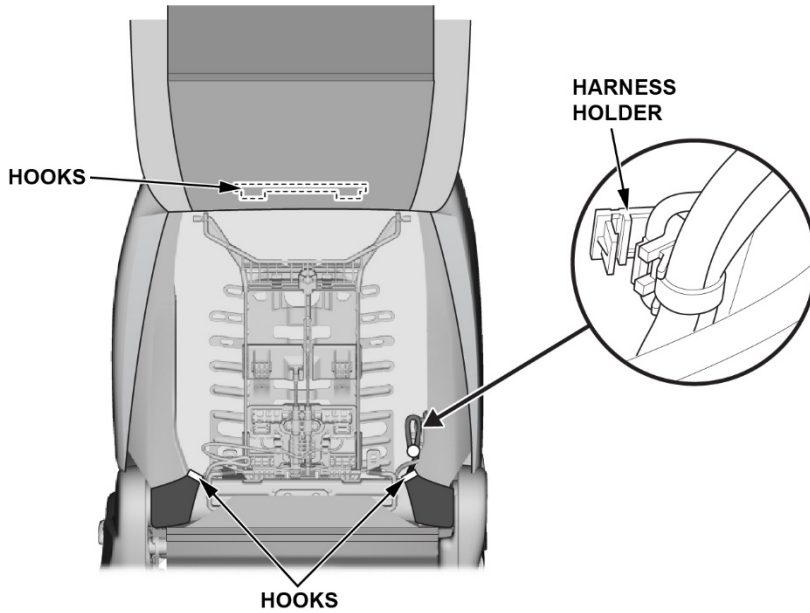

9. **With Seat Heater:** Remove the harness holder.

10. Remove the clips of the reinforcing cloth.

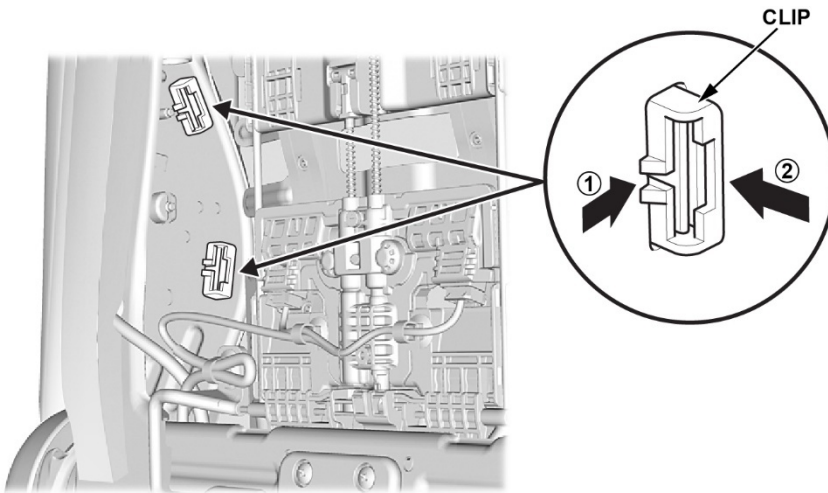

11. Release the harness clips, then remove the side airbag.

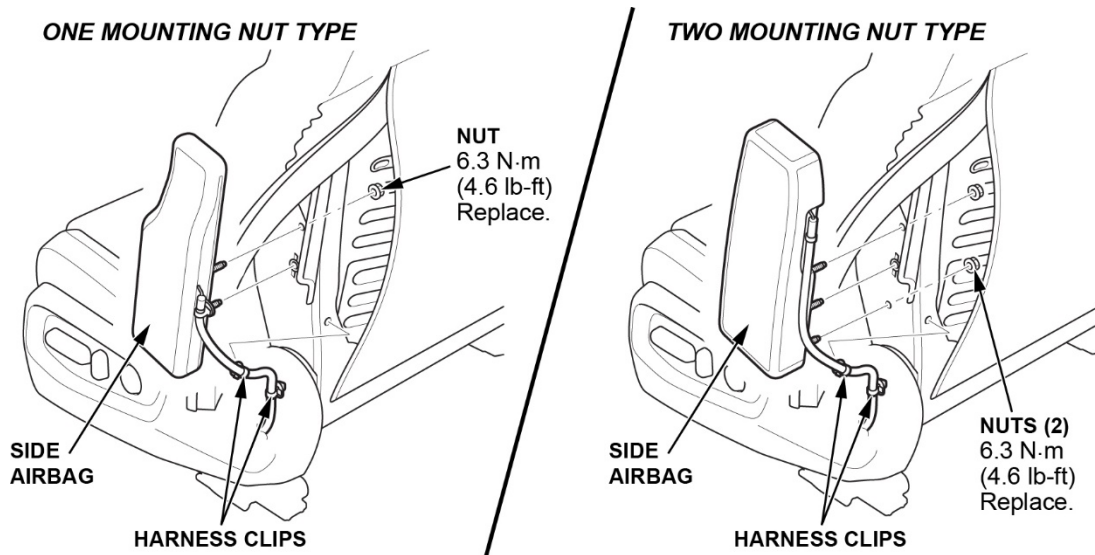

12. Remove the head restraint guides.

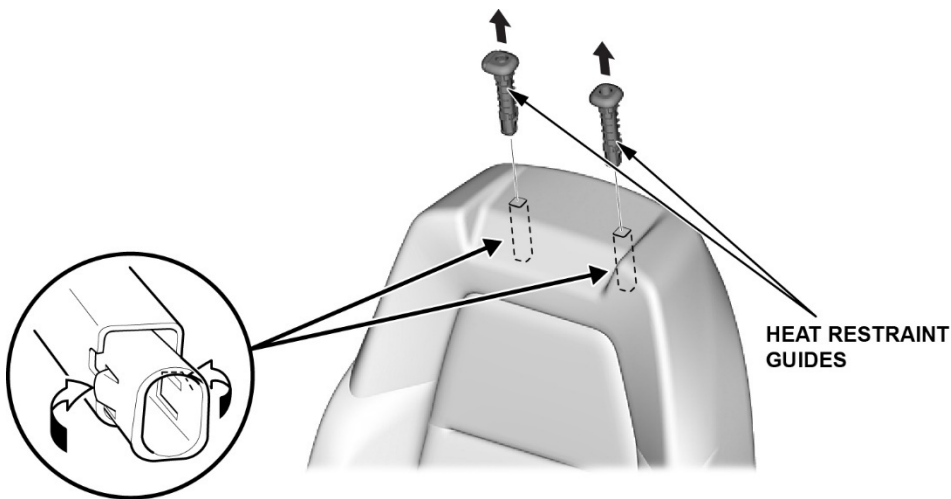

13. Remove the seat-back cover pad.

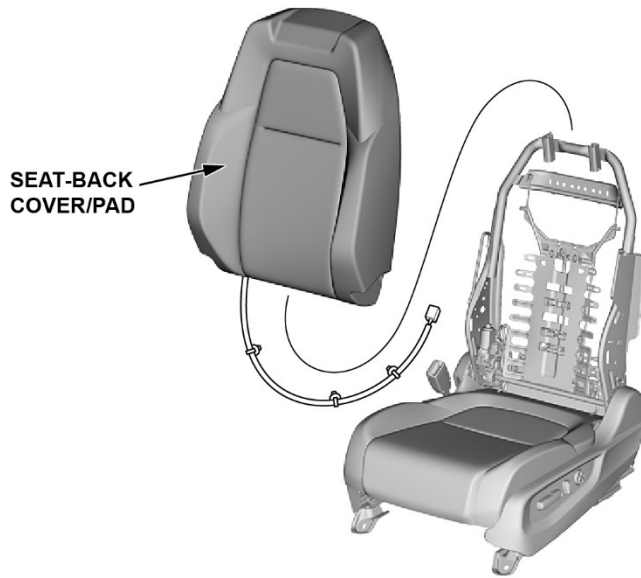

14. Remove the front seat recline knob.

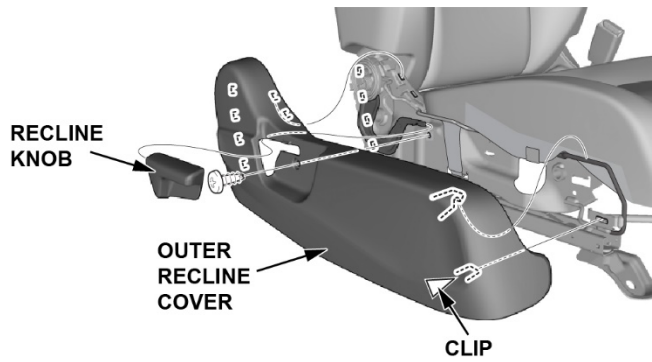

15. Remove the front seat outer recline cover.

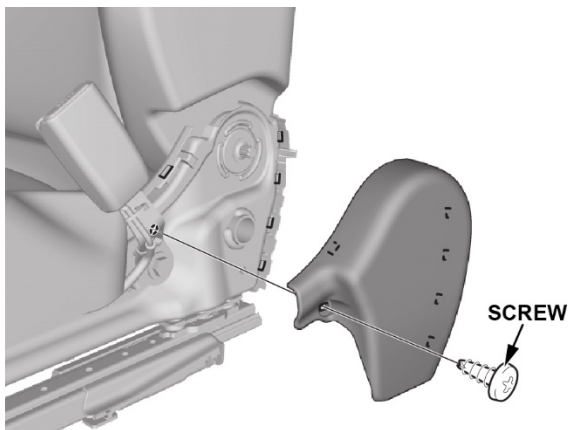

16. Release the harness clips and then remove the bolt from the seat belt buckle.

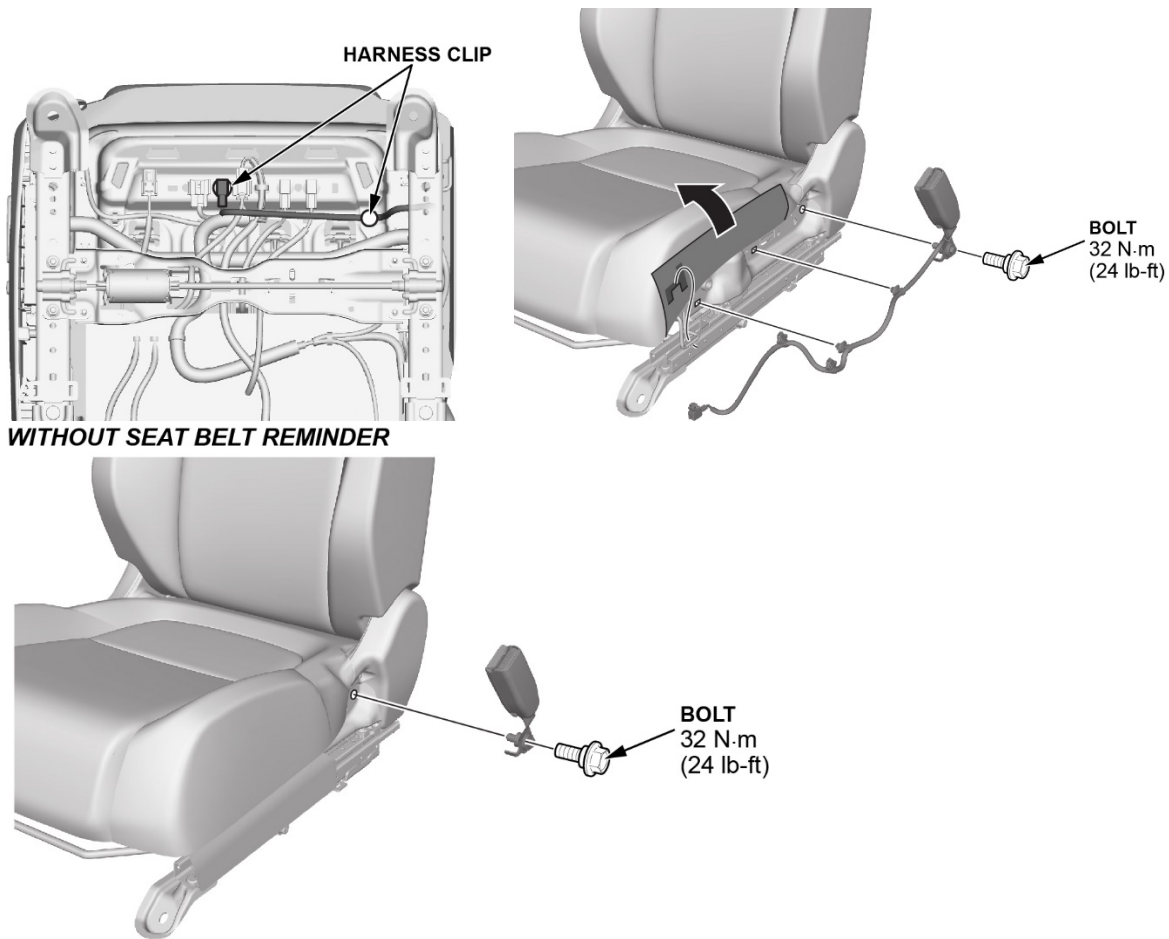

17. Release the hooks and the hook strips, then remove the seat cushion cover/pad.

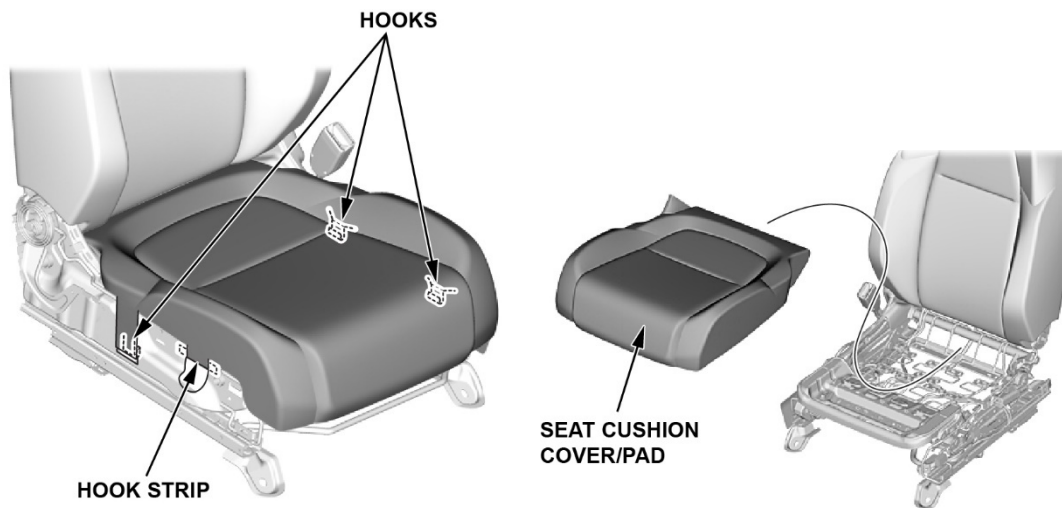

18. Remove the front seat outer/inner recline inner covers.

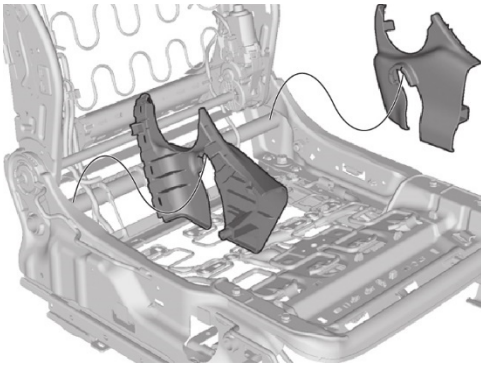

19. Remove the seat side airbag holder.

Fastener Locations

▶ : 2

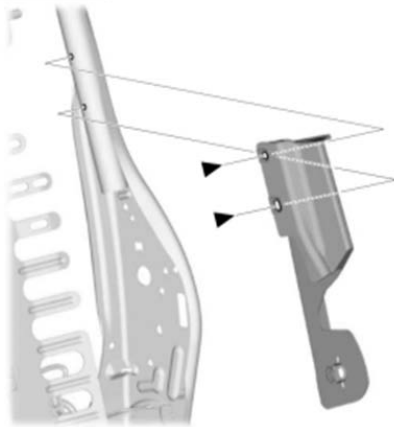

20. Remove the edge protectors.

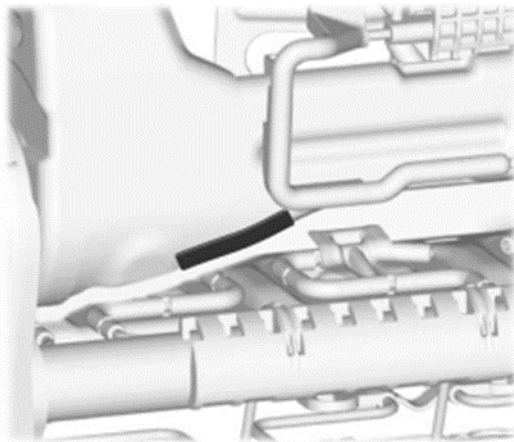

21. Install all parts in the reverse order of removal onto the replacement frame.

22. Connect the negative terminal of the 12-volt battery.

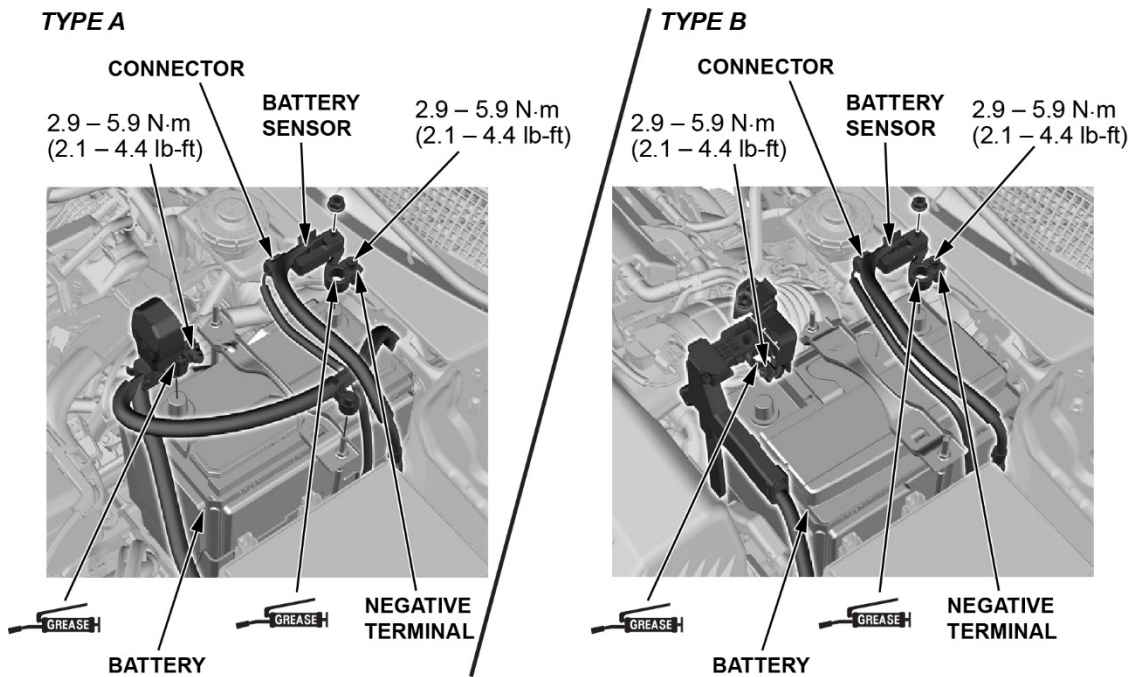

23. Install the bolts to the passenger's seat, and tighten the bolts by hand first, then tighten them to the specified torque in the sequence shown.

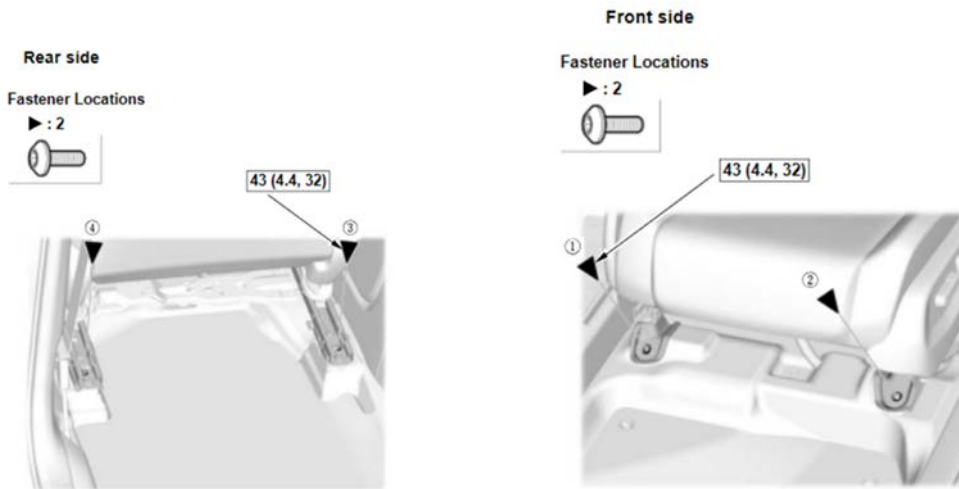

24. Do the seat weight sensor initialization [Click Here](#).

25. Do the front weight sensor operation check [\(Click Here\)](#).

26. Confirm the SRS Operation: Turn the vehicle to the ON mode, and check that the SRS indicator comes on for about **6 seconds** and then goes off.

27. Do the steering neutral position learn procedure using the method with the HDS [\(Click Here\)](#).

REPAIR PROCEDURE POWER SEAT

1. Disconnect the 12-volt battery.

TYPE A

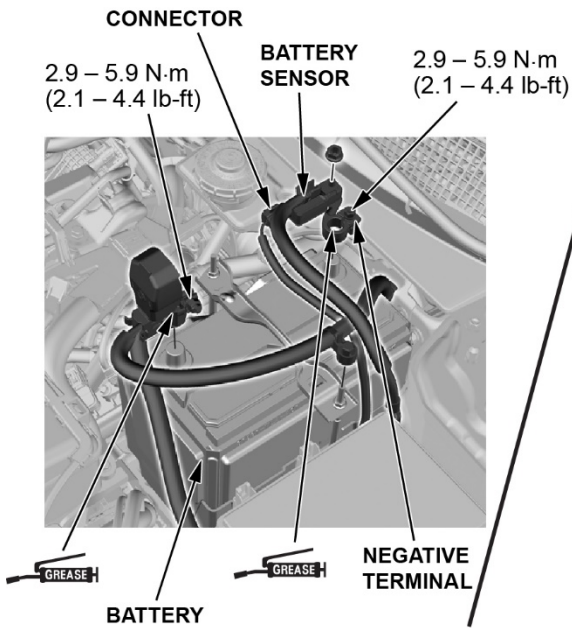

TYPE B

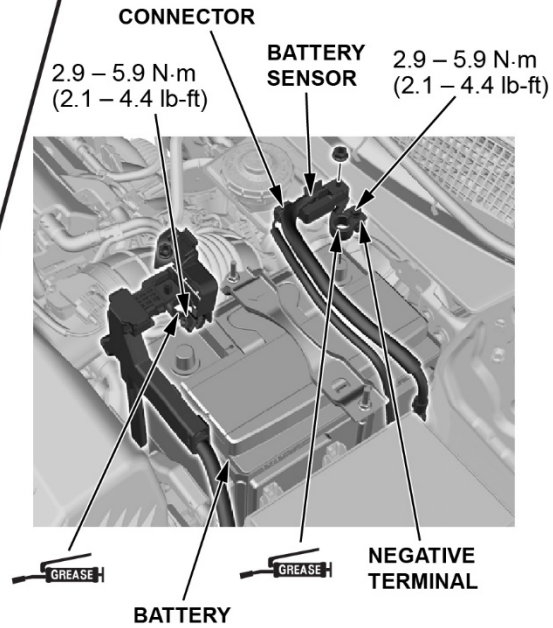

2. Disconnect the connectors.

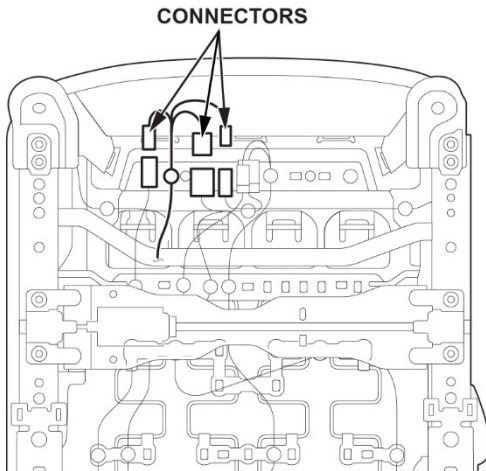

3. With the help of an assistant, carefully remove the front passenger's seat through the front door and place it on a clean, flat surface.
4. Remove the front seat recline covers.

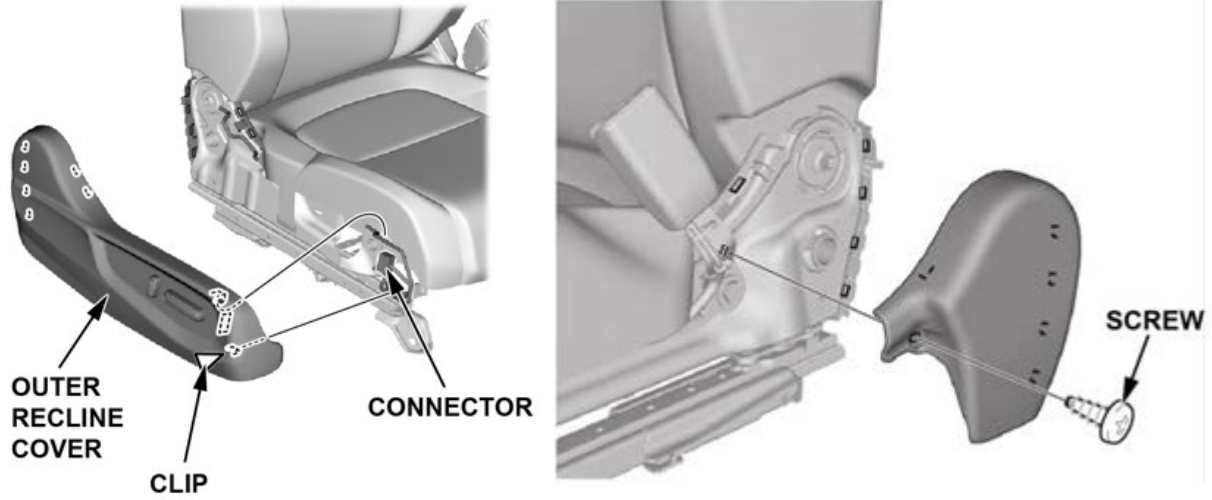

5. From under the seat cushion, release the elastic strap from the seat cushion frame springs.

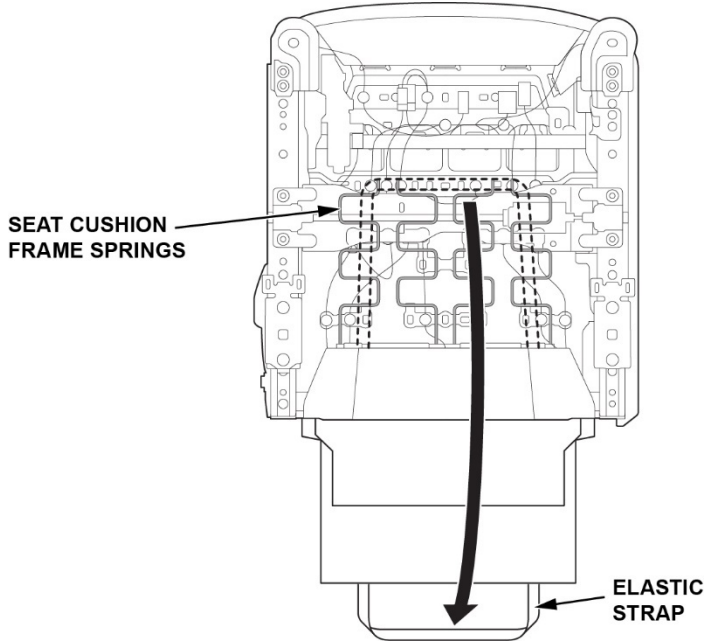

6. For some models: From under the seat cushion, disconnect the connectors, and remove the harness clips.

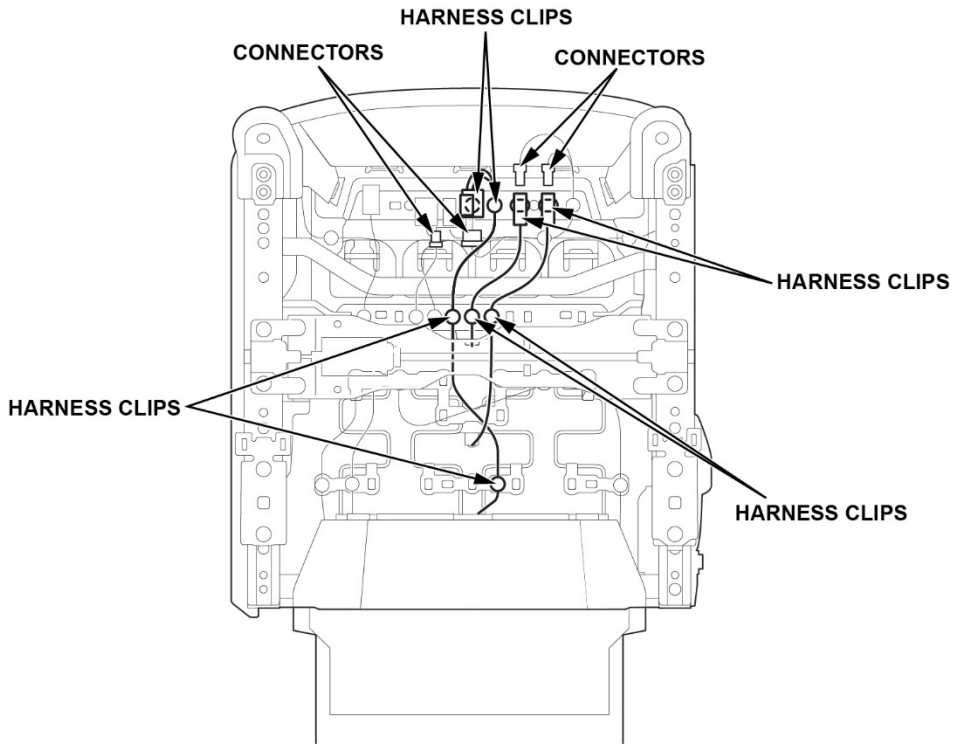

7. Release the hooks.

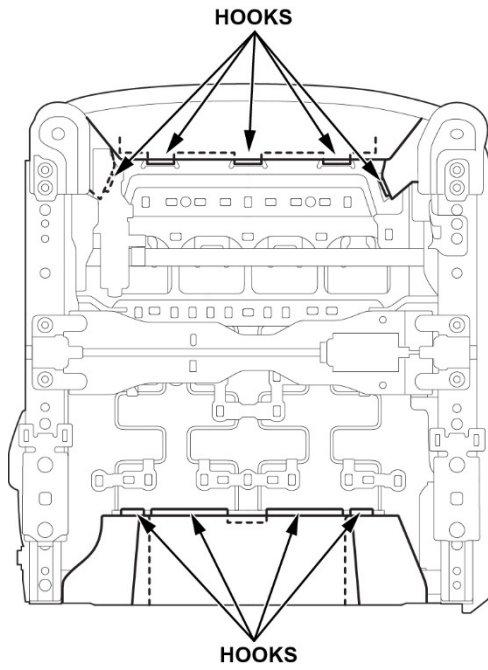

8. Disconnect the connector from the seat motor.

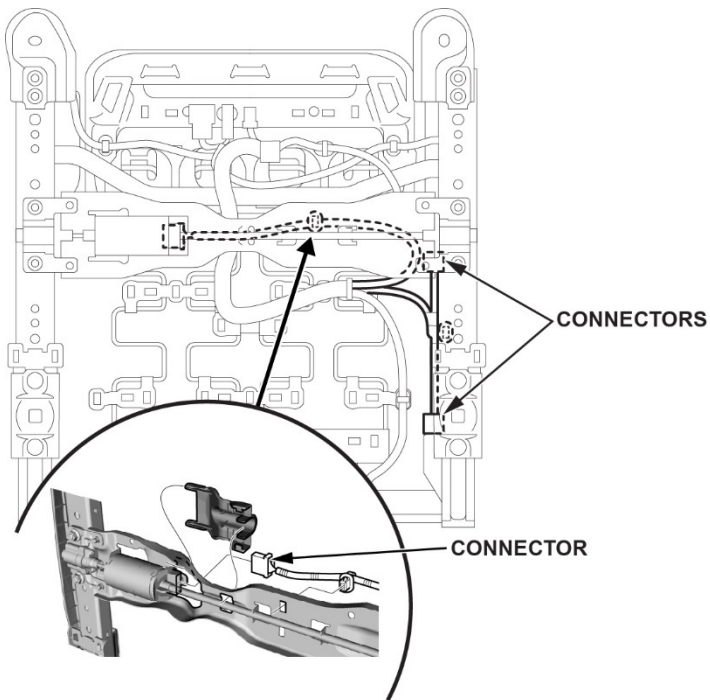

9. Release the hooks and the hook strip.

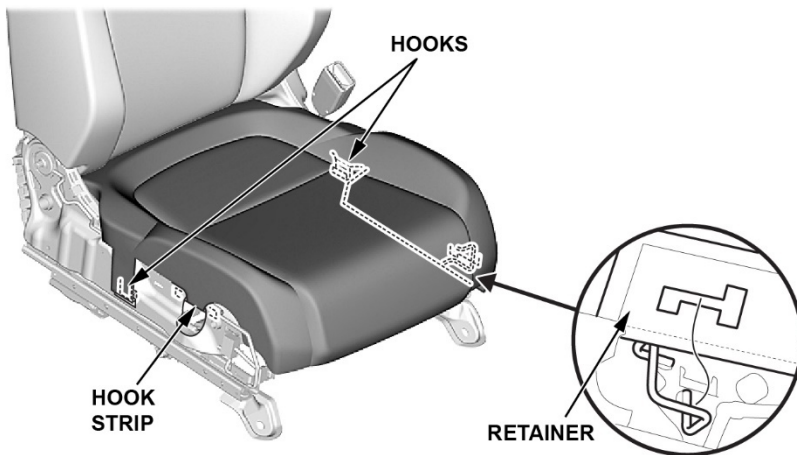

10. Remove the seat cushion cover. Some models, remove the silencer.

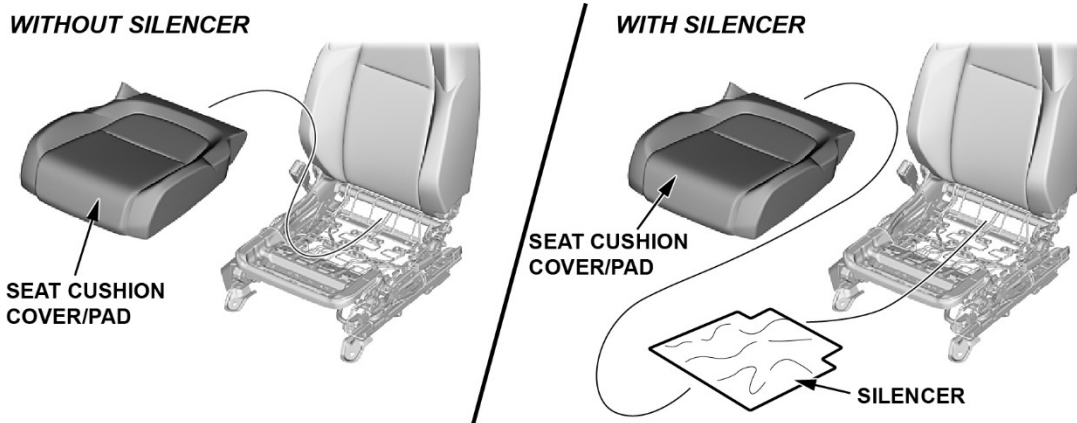

11. For some models: Remove the silencer.

12. Remove the seat rails from the seat.

NOTE:

- The bushings and collars can be identified by their color. Make sure to reinstall the bushings and collars as shown.
- Tighten the nuts in the numbered sequence shown.
- Take a picture of all four seat frame nuts, bushings, and collars for reference.

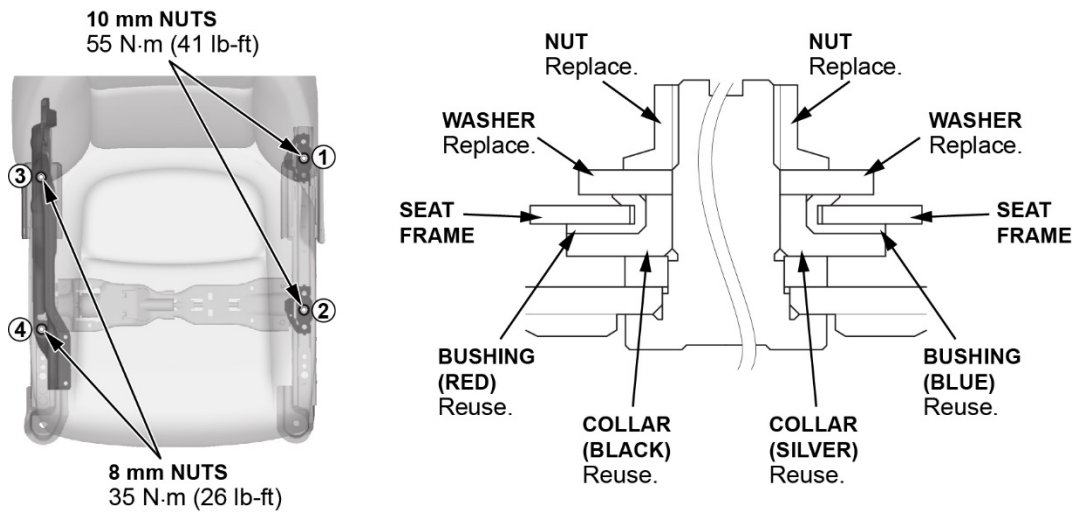

13. Replace with a new seat railing, then install in reverse order of removal.

14. Install the bolts to the passenger's seat and tighten the bolts by hand first, then tighten them to the specified torque in the sequence shown **43 N·m (32 lb-ft)**.

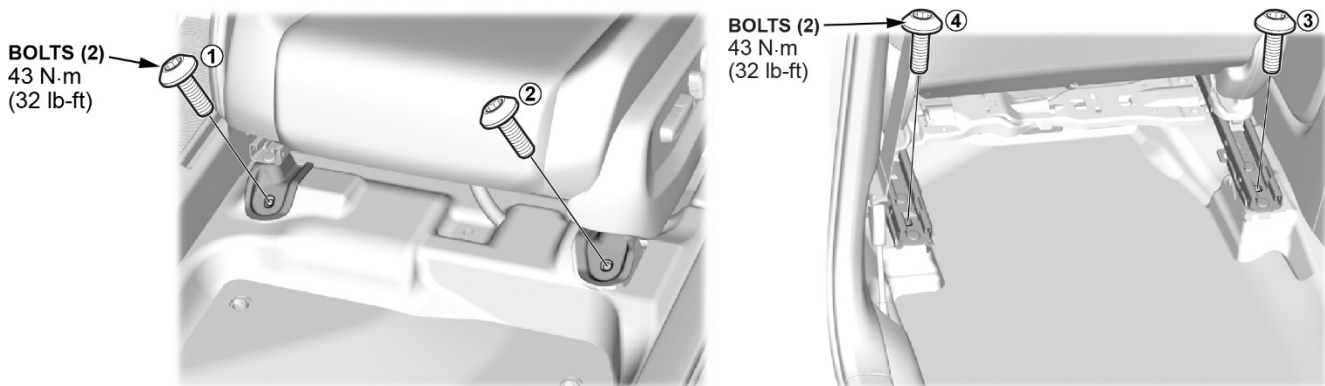

15. Connect the negative terminal of the 12-volt battery.

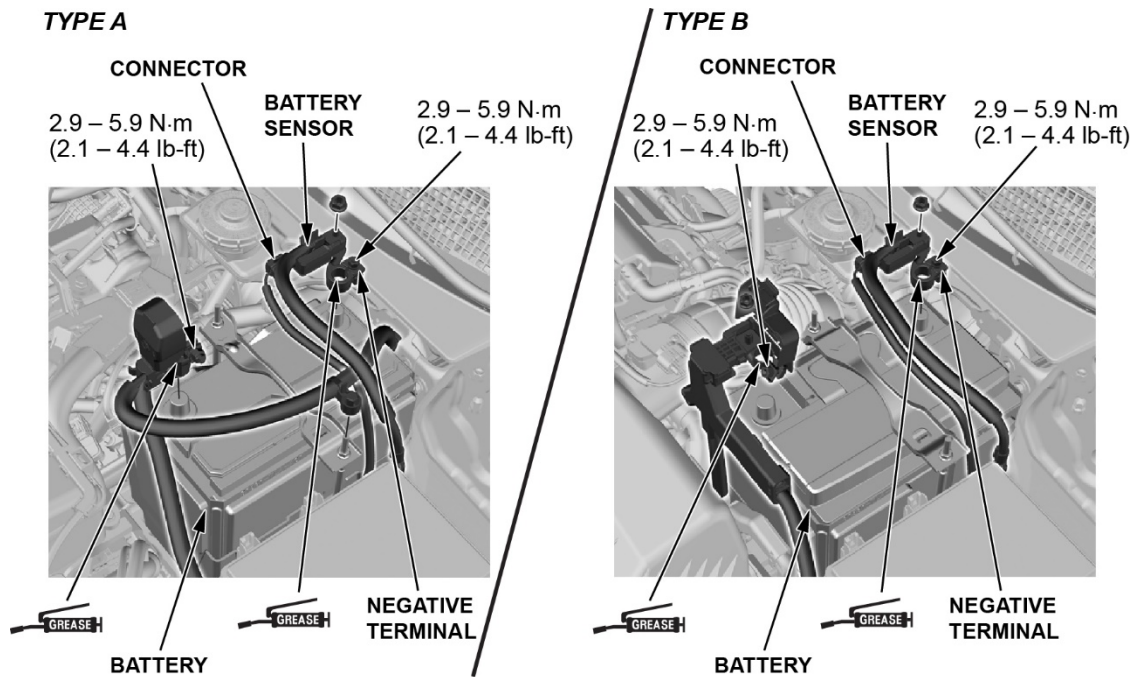

16. Do the seat weight sensor initialization ([Click Here](#)).

17. Do the front weight sensor operation check ([Click Here](#)).

18. Confirm the SRS Operation: Turn the vehicle to the ON mode, and check that the SRS indicator comes on for about **6 seconds** and then goes off.

19. Do the steering neutral position learn procedure using the method with the HDS ([Click Here](#)).