

October 8, 2024

Version 5

Safety Recall: 2020 TLX Seat Weight Sensor (DTC U3000-49)

Supersedes 24-017, dated July 17, 2024, to revise the information.

APPLIES TO

Year	Model	Trim Level	VIN Range
2020	TLX	ALL	Check the iN VIN status for eligibility.

REVISION SUMMARY

This service bulletin has been revised extensively; American Honda recommends you read the bulletin in its entirety.

BACKGROUND

Affected vehicles may be equipped with seat weight sensors that are not built to proper specifications. Improperly built sensors could lead to cracking and/or a short circuit of the sensor, resulting in the illumination of the SRS warning light and the passenger airbag indicator remaining OFF. In certain collisions, these seat weight sensors may cause improper deployment of the front passenger airbags, increasing the risk of injury.

CLIENT NOTIFICATION

Owners of the affected vehicles will be sent a notification of this campaign. Do an iN VIN status inquiry to make sure the vehicle is shown as eligible. Some vehicles affected by this campaign may be in your new or used vehicle inventory.

Failure to repair a vehicle subject to a recall or campaign may subject your dealership to claims or lawsuits from the client or anyone else harmed because of such failure. To verify if a vehicle in inventory is affected, do a VIN status inquiry before selling it.

CORRECTIVE ACTION

Replace the seat weight sensors.

CLIENT INFORMATION: The information in this bulletin is intended for use only by skilled technicians who have the proper tools, equipment, and training to correctly and safely maintain your vehicle. These procedures should not be attempted by “do-it-yourselfers,” and you should not assume this bulletin applies to your vehicle, or that your vehicle has the condition described. To determine whether this information applies, contact an authorized Acura automobile dealer.

WARRANTY CLAIM INFORMATION

For repairs on or after October 8, 2024, you must use the warranty claim information with Template ID C.

For inspection or repairs before to October 8, 2024, go to page 2.

2.4 Base, Tech

Operation Number	Description	Flat Rate Time	Defect Code	Symptom Code	Template ID	Failed Part Number
7491E4	Replace 4-way seat weight sensor - power seat (includes DTC check).	1.1 hr	6XW00	UHE00	B24017E	81205-TZ3-A12
7491E4	Replace 8-way seat weight sensor - power seat (includes DTC check).	1.1 hr	6XW00	UHE00	B24017E	81205-TZ3-A22

Skill Level: Repair Technician

Seat Weight Sensor Kit Serial Number

Enter the Seat Weight Sensor Kit serial number from the Seat Weight Sensor Kit label into the Replacement Serial Number field of the Parts Information section of the warranty claim.

NOTE:

- The Seat Weight Sensor Kit label should be affixed to the repair order by the technician.
- The claim may be rejected if a valid serial number is not included.

Parts Information						
Failed Part No.▪	<input type="text"/>		Failed Part Description▪	<input type="text"/>		
Replacement Serial No.	<input type="text"/>					
Item	Replacement Part No.▪	Quantity▪	Unit Price	Unit Total	Description	
1	<input type="text"/>	<input type="text"/>	<input type="text"/>	<input type="text"/>	<input type="text"/>	Delete
2	<input type="text"/>	<input type="text"/>	<input type="text"/>	<input type="text"/>	<input type="text"/>	Delete
3	<input type="text"/>	<input type="text"/>	<input type="text"/>	<input type="text"/>	<input type="text"/>	Delete
4	<input type="text"/>	<input type="text"/>	<input type="text"/>	<input type="text"/>	<input type="text"/>	Delete
5	<input type="text"/>	<input type="text"/>	<input type="text"/>	<input type="text"/>	<input type="text"/>	Delete
<input type="button" value="More >"/>						
Materials Information						

For repairs before to October 8, 2024, you must use the warranty claim information with Template IDs ending in A, B, C, and D.

NOTE: If the INSPECTION PROCEDURE determines this Service Bulletin doesn't apply, use template D to submit a warranty claim for the inspection.

2.4 Base, Tech

Operation Number	Description	Flat Rate Time	Defect Code	Symptom Code	Template ID	Failed Part Number
7491E3	Replace power seat rail assembly (includes inspection and DTC check).	1.5 hr	6XW00	UHE00	B24017A	81205-TZ3-A12

2.4 A-Spec; 3.5 Base, Tech, A-Spec

7491E3	Replace power seat rail assembly (includes inspection and DTC check).	1.5 hr	6XW00	UHE00	B24017B	81205-TZ3-A22
--------	---	--------	-------	-------	---------	---------------

3.5 AWD Base, Tech, Advance

7491E3	Replace power seat rail assembly (includes inspection and DTC check)	1.5 hr	6XW00	UHE00	B24017C	81205-TZ7-A22
--------	--	--------	-------	-------	---------	---------------

Inspection Only

7495A1	For stored DTCs other than DTC U3000-49 and/or inspection determines this Service Bulletin does not apply.	0.3 hr	6XZ00	FIU00	B24017D	81136-T20-A61
--------	--	--------	-------	-------	---------	---------------

PARTS INFORMATION

Seat Weight Sensor Kit, P/N 04945-T5R-A00 has been allocated to dealers in limited quantities. Acura will continue to allocate kits on a weekly basis. Refer to the Parts Information Bulletin 24-0012, *Multi-Model Seat-Weight Sensor Safety Recall Parts Availability*, for detail regarding parts availability and ordering.

TOOL INFORMATION

NOTE: Tools will be made available and auto-shipped to all dealers.

Tool Name	Tool Number	Quantity
Snap-On Torque Wrench	07AAA-TVAA400	1
Box End Head (16MM)	07AAA-TG7A300	1
SWS Fixture Guide C	07AAG-TVAA300	1

4. Remove the rear bolts of the front passenger's seat.

NOTE:

- **Thigh Support Only:** Slide the thigh support all the way forward.
- **8-way Power Seat Only:** Raise the front seat all the way up.

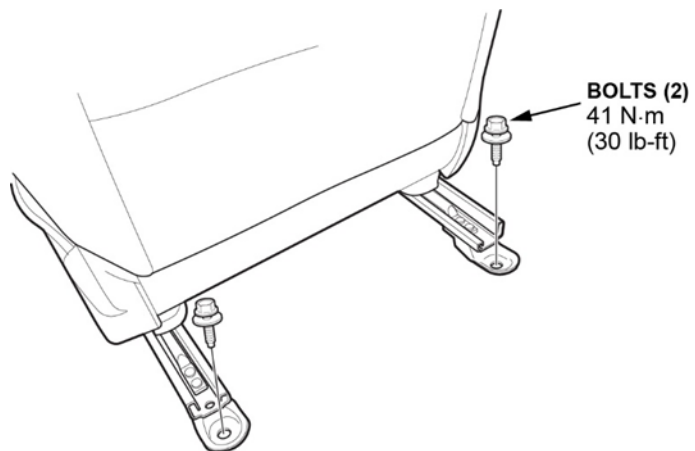

5. Slide the seat all the way back and remove the front passenger's seat mounting bolts.

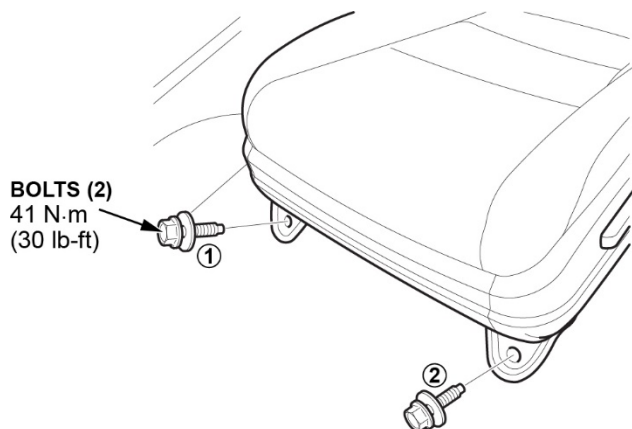

6. Disconnect and isolate the negative cable with the 12-volt battery sensor from the 12-volt battery **2.9—5.9 N·m (2.1—4.4 lb-ft)**.

NOTE:

- Always disconnect the negative side first.
- To protect the 12-volt battery sensor connector from damage, do not hold it when removing the negative terminal.
- Do not disconnect the 12-volt battery sensor from the negative terminal.
- Wait at least **3 minutes** before starting work.

L4 ENGINE

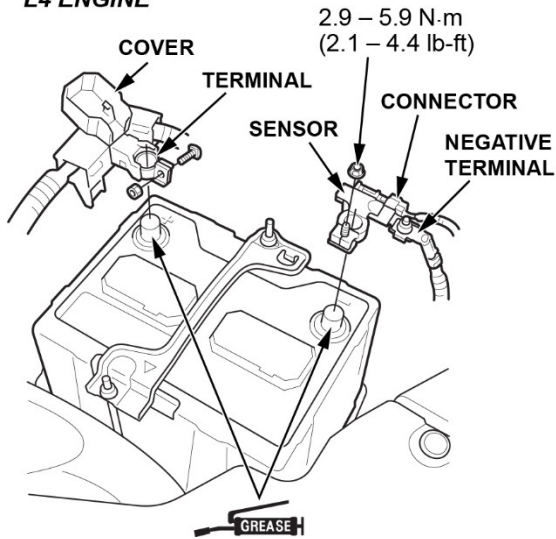

V6 ENGINE

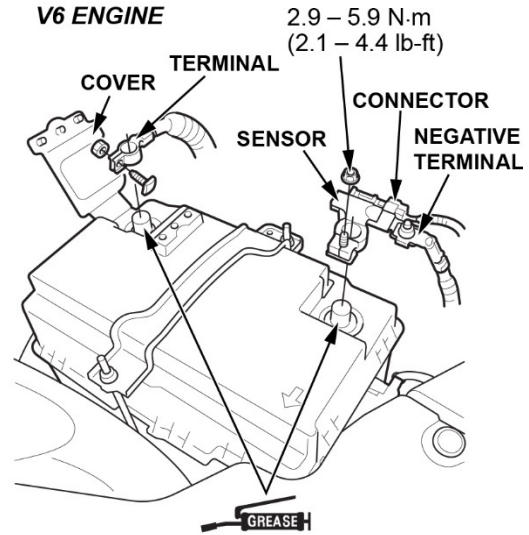

7. Remove the front seat belt lower anchor cover and the lower anchor bolt.

LEFT SIDE SHOWN

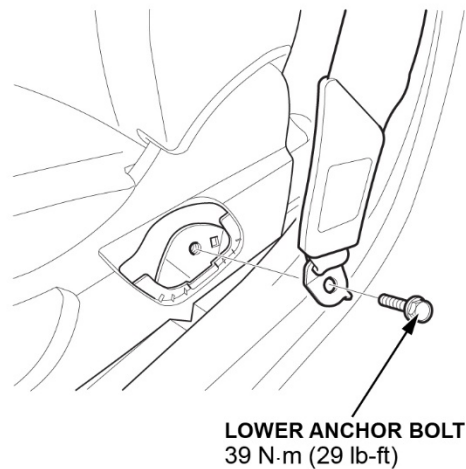
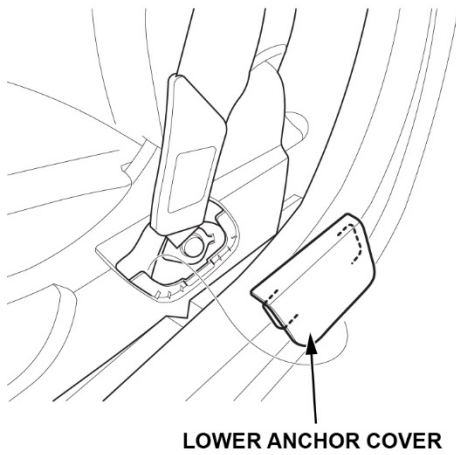

8. Make sure the ignition is in the OFF (LOCK) mode.

9. Lift up the front seat, then remove these items:

1. Remove the harness clip.

CONNECTORS

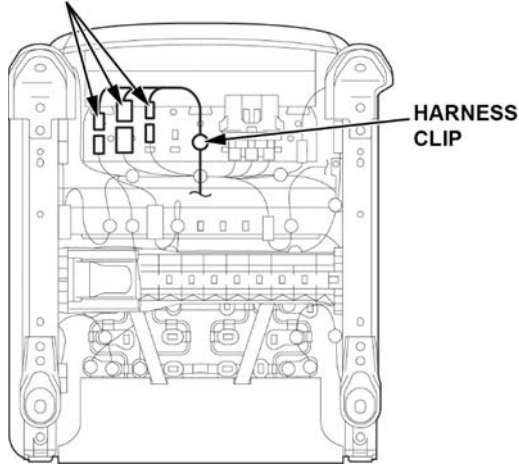

2. Disconnect the connector.
3. Remove the head restraint.
4. With the help of an assistant, carefully remove the front seat through the front door.

10. Remove the passenger's front seat front cover and front seat recline cover.

WITH THIGH SUPPORT

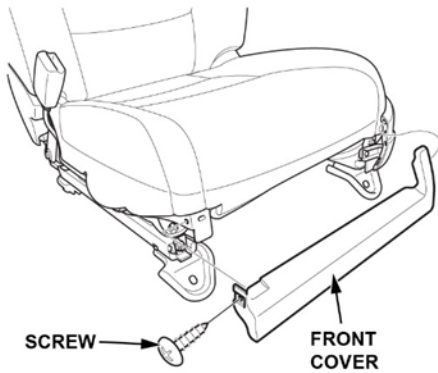

WITHOUT THIGH SUPPORT

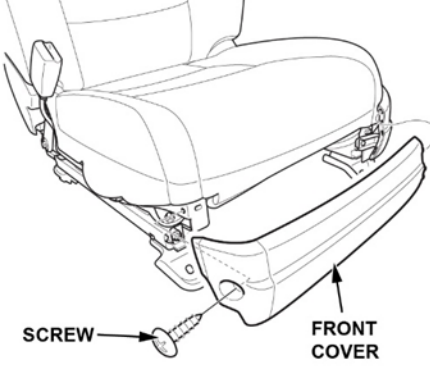

WITH THIGH SUPPORT

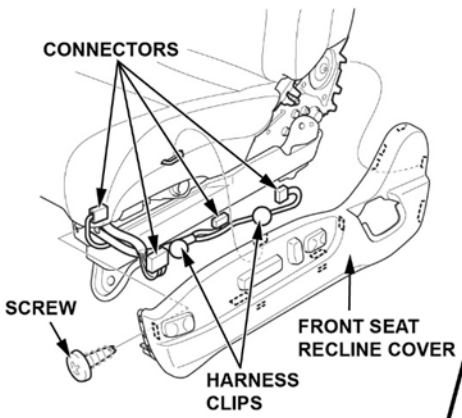

WITHOUT THIGH SUPPORT

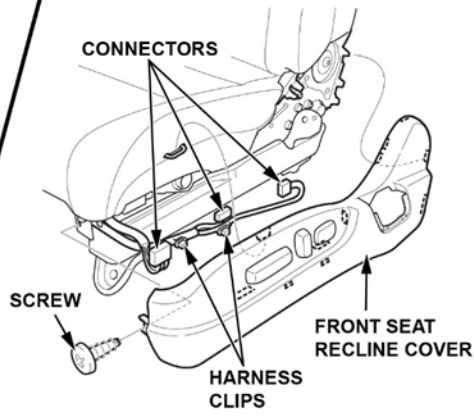

11. Remove the front seat frame upper inner and outer rail covers.

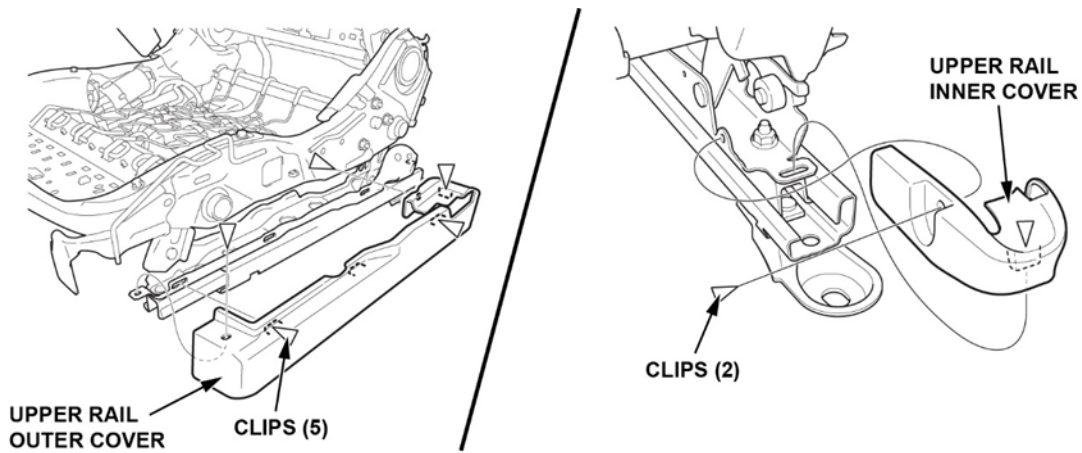

12. Remove the seat belt buckle.

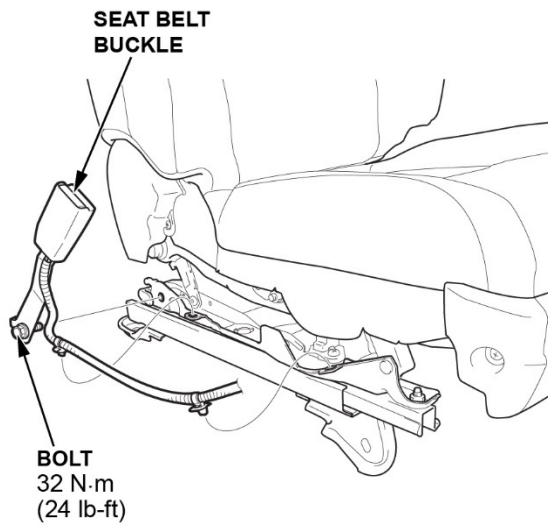

13. Disconnect the seat harness and then remove the 4 clips.



14. Remove the nuts, then remove the front passenger's seat side/up-down adjuster link.

NOTE: Discard the nuts after removal.

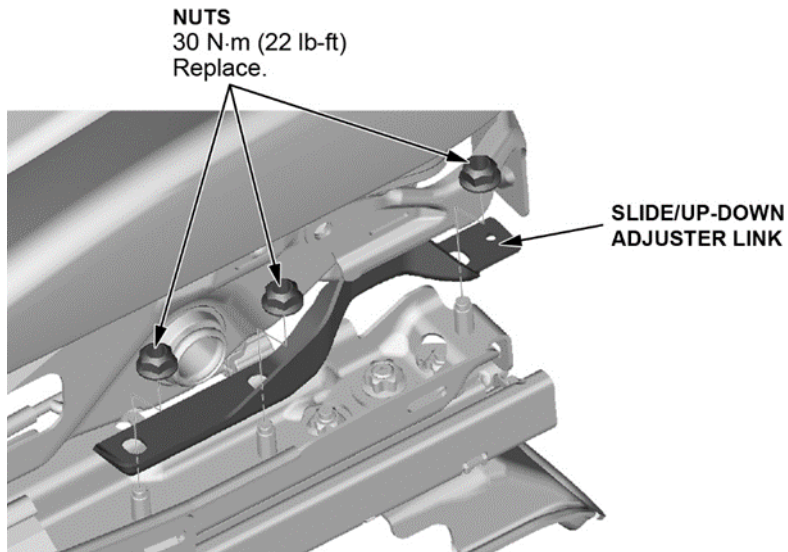

15. Remove the two bolts from the seat bracket and the two nuts, then remove the front passenger's seat rail as an assembly.

NOTE: Note the color and location of the collars and the bushings during disassembly.

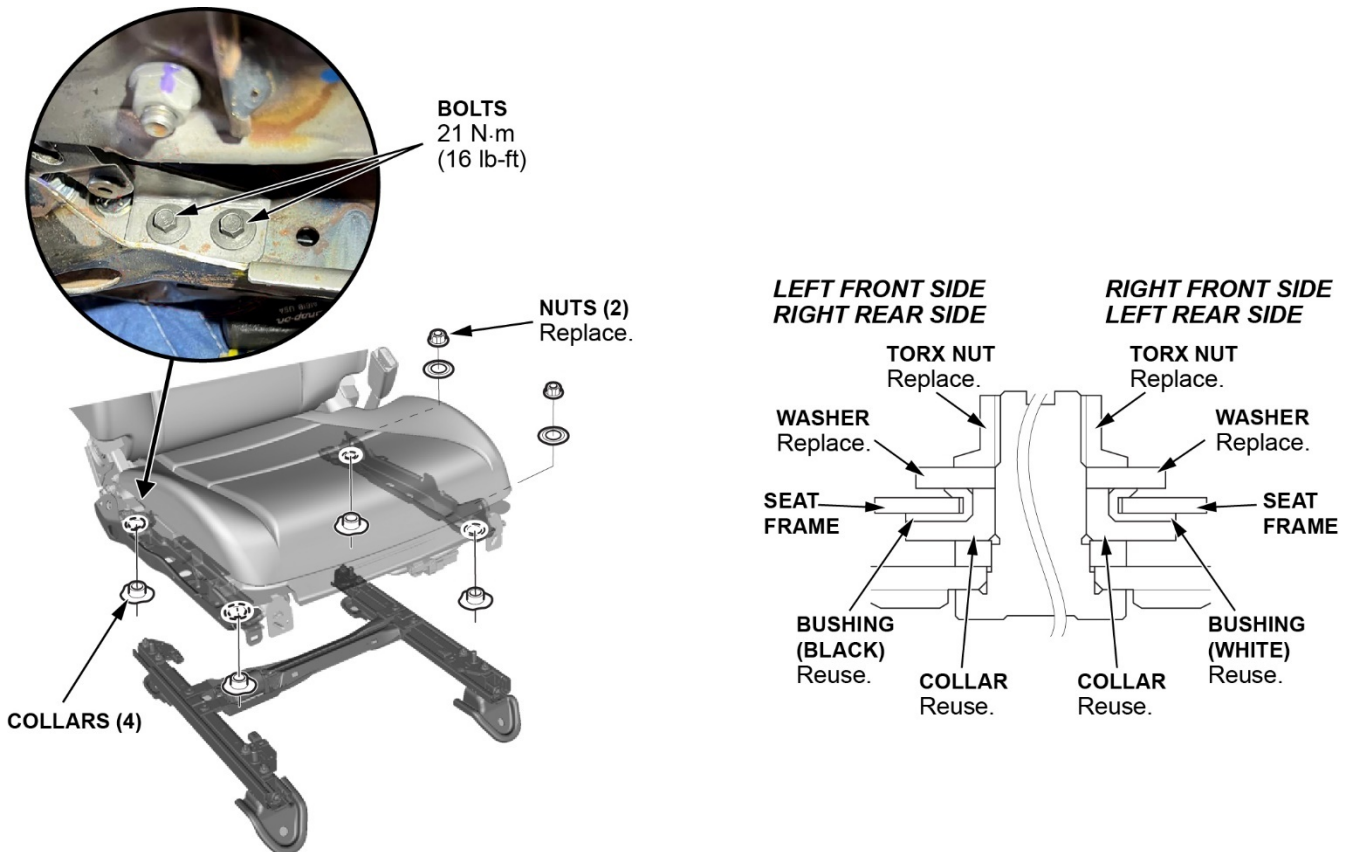

16. Remove the right top bracket from the seat rail.

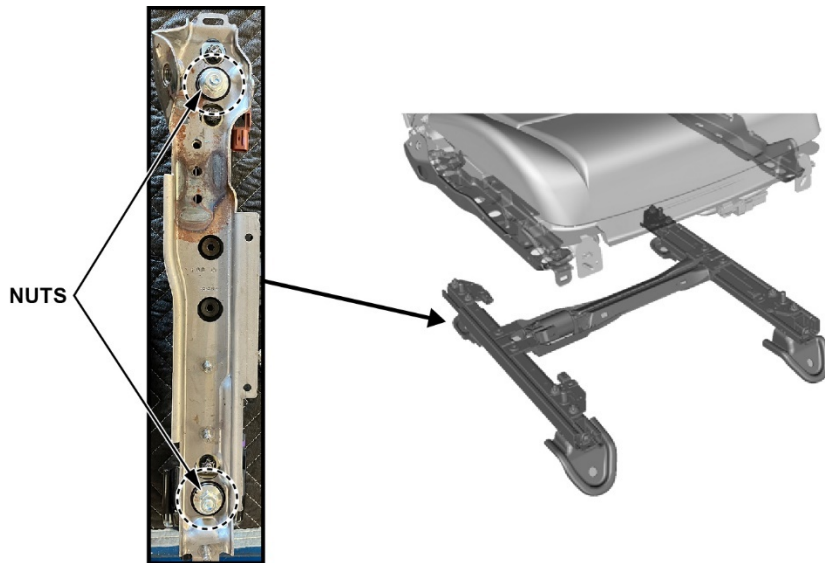

17. Mount the seat rail in the vehicle with the bolts and remove the 4 seat weight sensors, then discard the nuts and sensors.

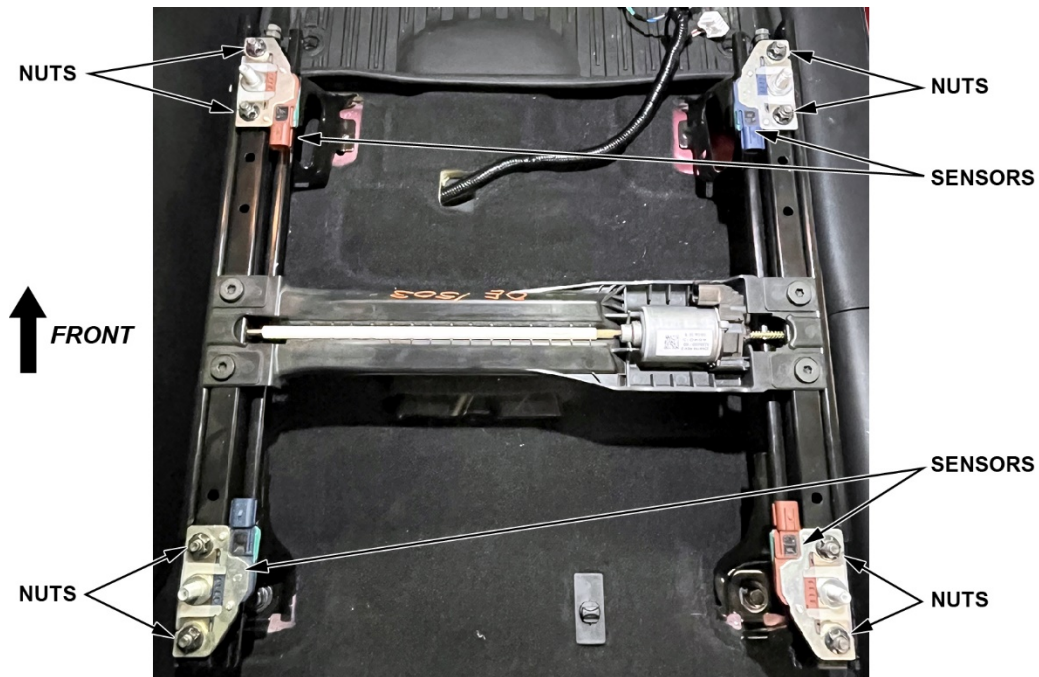

18. Install the new sensors and nuts in the orientation shown.

NOTE: The new sensors have a number for installation in the correct location.

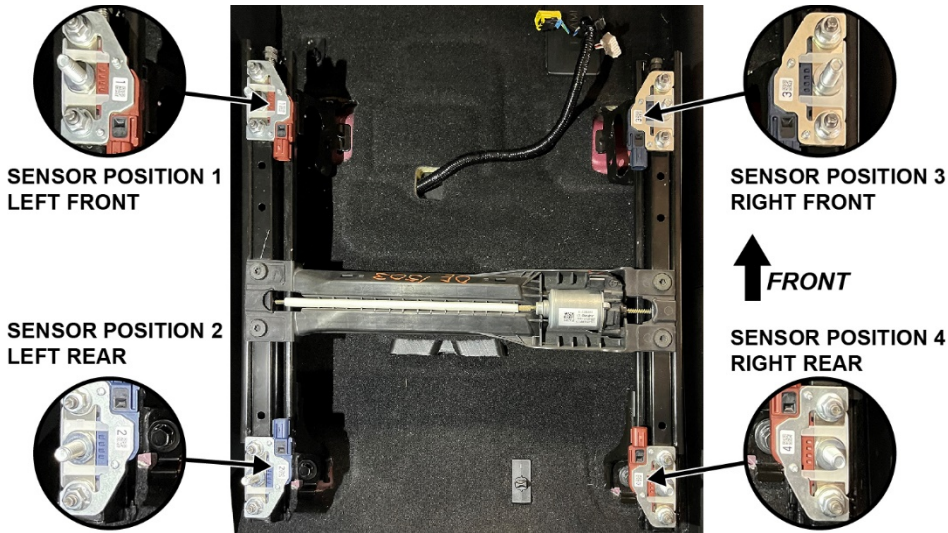

19. Place the **SWS Fixture Guide C** onto the new seat weight sensors with the tabs located on the inside of the seat track. Using the guide properly seated on the new sensors and torque the nuts to **35 N·m (26 lb-ft)** in the order shown on the SWS Fixture Guide.

NOTE: Use the socket provided with the guide.

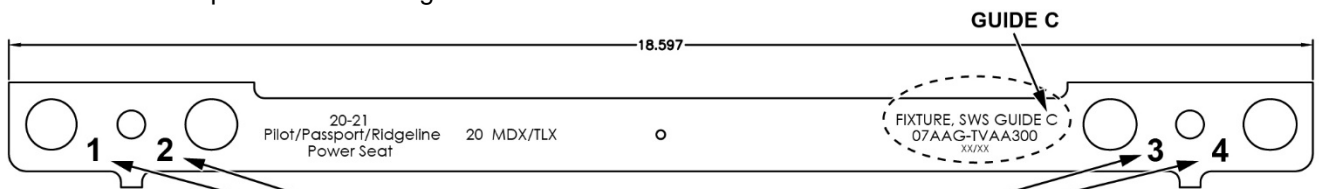

TORQUE SEQUENCE

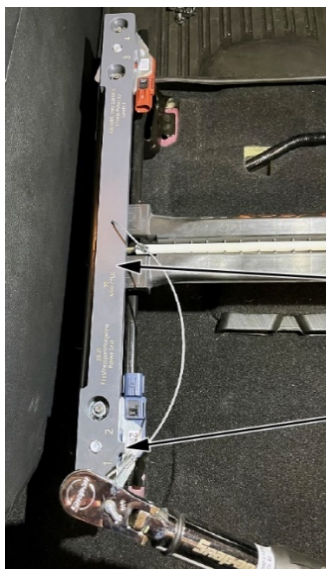

SWS FIXTURE GUIDE

TABS
Tabs located
to the inside.

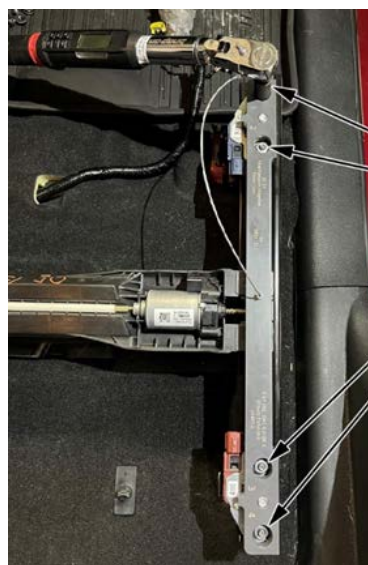

8mm NUTS
35 N·m (26 lb-ft)

20. Remove the rail from the vehicle. Install the front passenger's seat rail back onto the seat frame, loosely install the new nuts and bolts, and reinstall all parts.

NOTE: The bushings and collars can be identified by their color. Make sure to install the bushings and collars as shown.

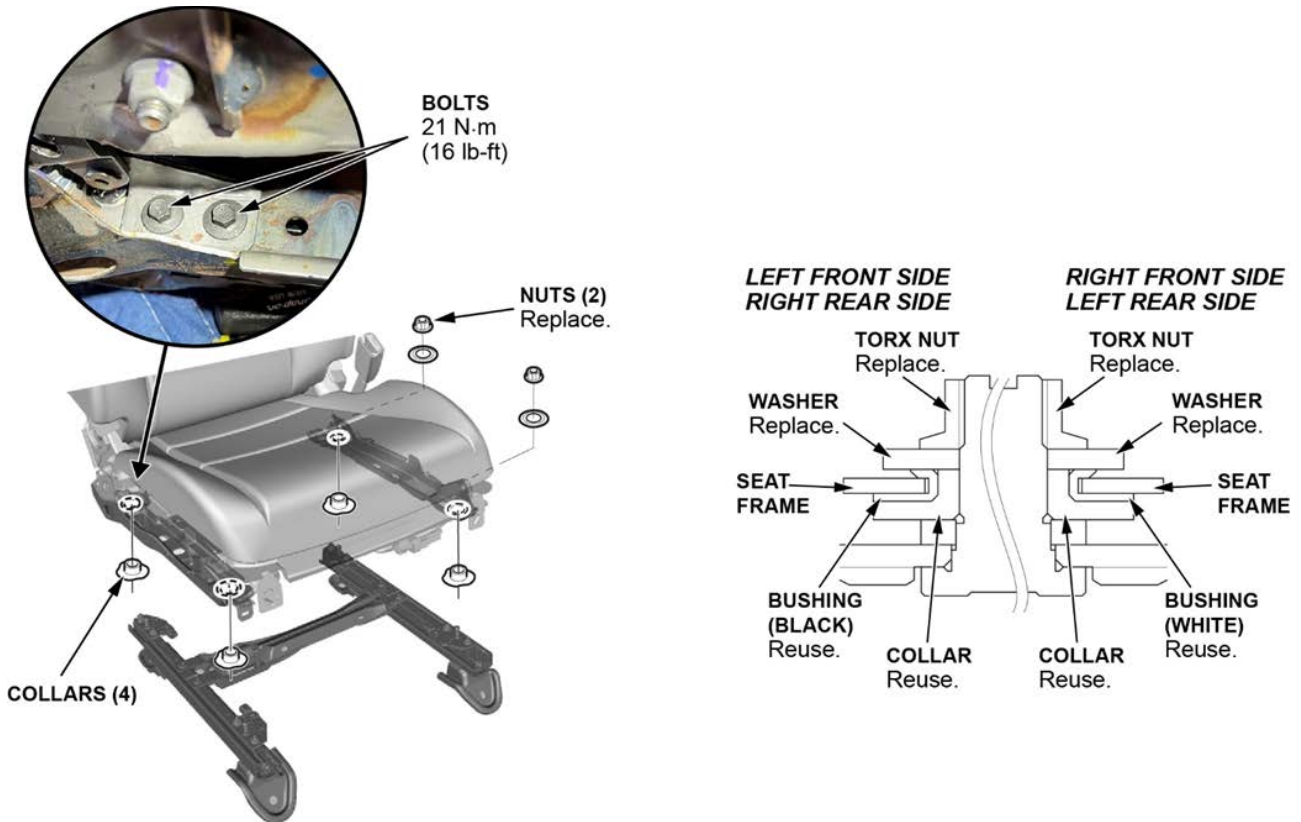

21. Install the nuts to the slide/up-down adjuster link and torque to **30 N-m (22 lb-ft)**.

NOTE: The replacement nuts are silver.

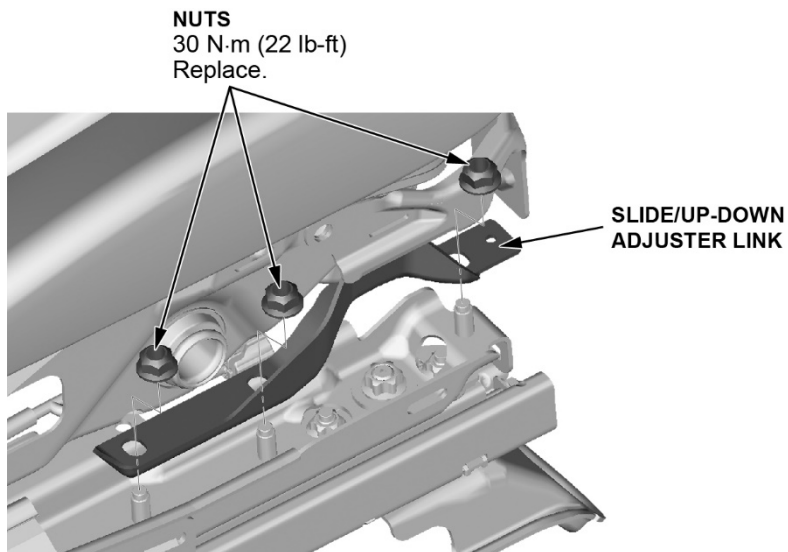

22. Torque the nuts to **55 N·m (41 lb-ft)**.

NOTE: Use the Snap-On Torque Wrench (07AAA-TVAA400) and the 16mm box-end head to tighten the seat rail nuts.

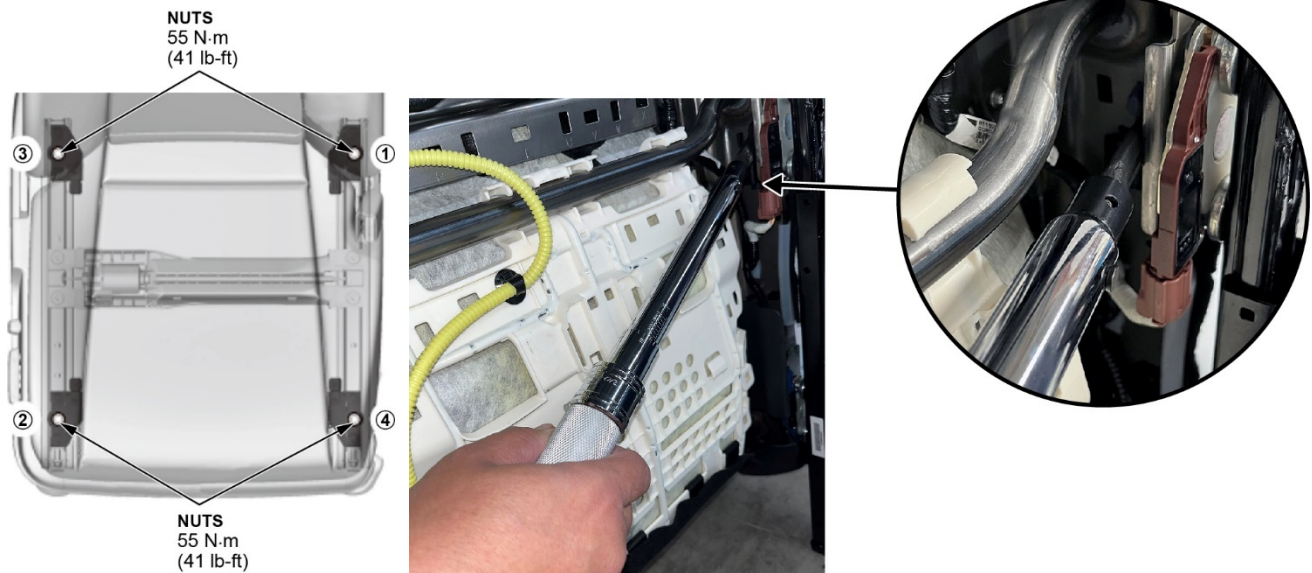

23. Connect the connectors and the clips.

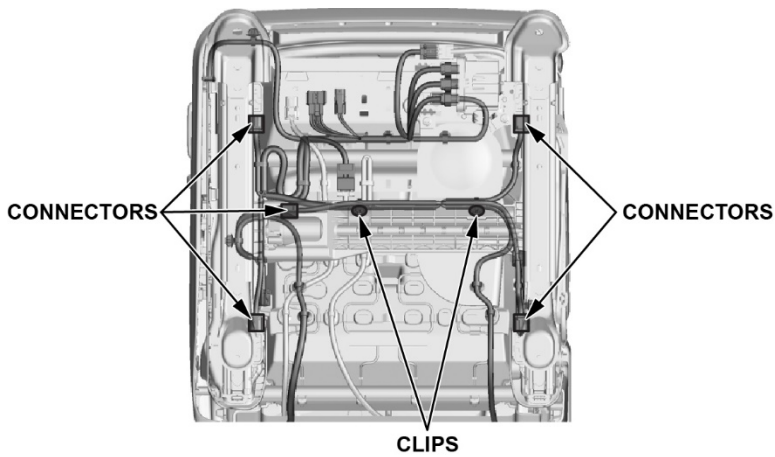

24. Install all remaining parts in the reverse order of removal.

NOTE: When installing the seat, tighten the bolts by hand first, then tighten them to the specified torque in the sequence shown.

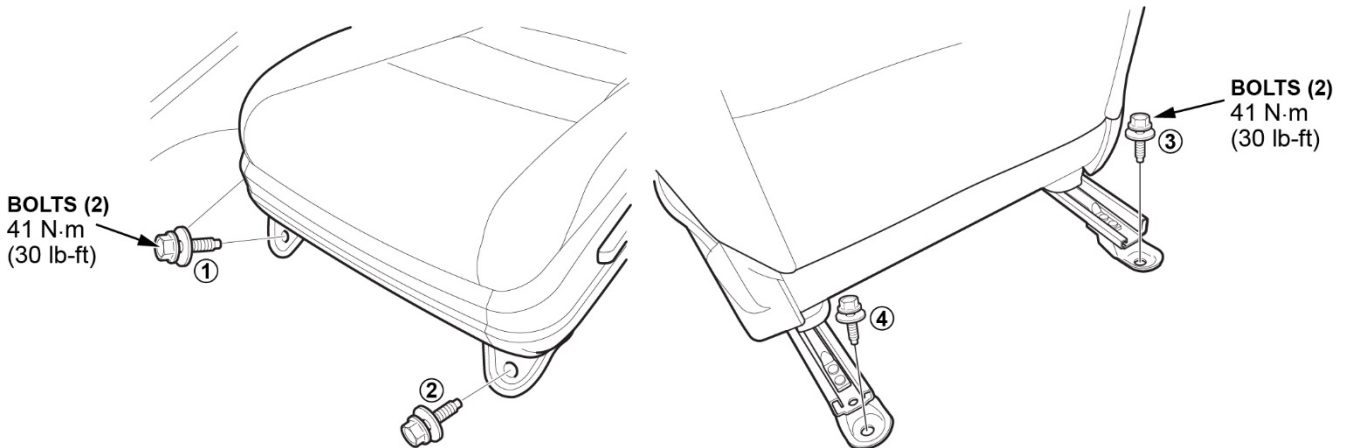

25. Connect the negative cable and the 12-volt battery sensor to the 12-volt battery.

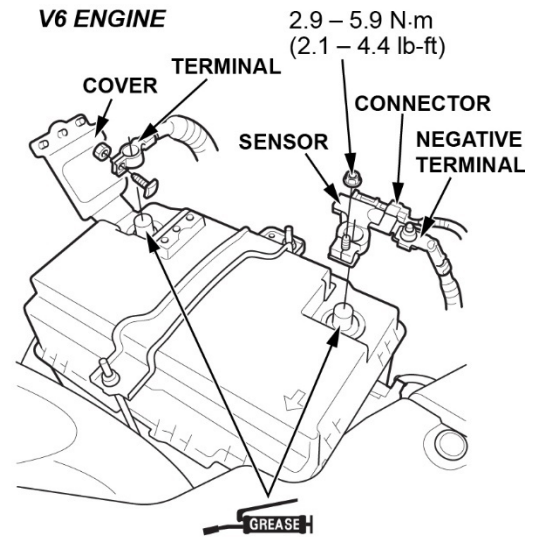
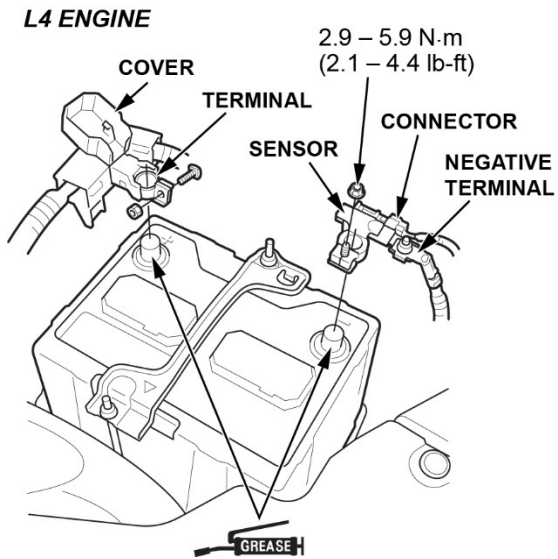

NOTE: To protect the 12-volt battery sensor connector from damage, do not hold it when installing the negative terminal.

26. Do the *Front Passenger's Seat Weight Sensor Initialization* ([CLICK HERE](#)).

27. Do the *Front Passenger's Seat Weight Sensor Operation Check* ([CLICK HERE](#)).