

March 21, 2024

Version 3

Safety Recall: 2020-22 Odyssey Seat Weight Sensor (DTC U3000-49)

Supersedes 24-020, dated March 8, 2024, to revise the information.

AFFECTED VEHICLES

Year	Model	Trim Level	VIN Range
2020-22	Odyssey	ALL	Check the iN VIN status for eligibility.

REVISION SUMMARY

This service bulletin has been revised extensively; American Honda recommends reading this bulletin in its entirety.

BACKGROUND

Affected vehicles may be equipped with seat weight sensors that are not built to proper specifications. Improperly built sensors could lead to cracking and/or a short circuit of the sensor, resulting in the illumination of the SRS warning light and the passenger airbag indicator remaining OFF. In certain collisions, these seat weight sensors may cause improper deployment of the front passenger airbags, increasing the risk of injury.

CUSTOMER NOTIFICATION

Owners of the affected vehicles will be sent a notification of this campaign.

Do an iN VIN status inquiry to make sure the vehicle is shown as eligible.

Some vehicles affected by this campaign may be in your new or used vehicle inventory.

Failure to repair a vehicle subject to a recall or campaign may subject your dealership to claims or lawsuits from the client and/or anyone else harmed as a result of such failure. To verify if a vehicle in inventory is affected, do a VIN status inquiry before selling it.

CORRECTIVE ACTION

- If the SRS indicator light is not illuminated, refer to campaign notice 24-050.
- If the SRS indicator light is illuminated, follow the inspection procedure outlined in this bulletin.

PARTS INFORMATION

Due to a limited supply of controlled parts, they require prior approval before shipping. This will be determined by the INSPECTION PROCEDURE, follow the steps provided by the QR code.

CUSTOMER INFORMATION: The information in this bulletin is intended for use only by skilled technicians who have the proper tools, equipment, and training to correctly and safely maintain your vehicle. These procedures should not be attempted by "do-it-yourselfers," and you should not assume this bulletin applies to your vehicle, or that your vehicle has the condition described. To determine whether this information applies, contact an authorized Honda automobile dealer.

TOOL INFORMATION

Tool Name	Part Number	Quantity
Belt Buckle Tool	07AAF-TG7A100	1

WARRANTY CLAIM INFORMATION

Operation Number	Description	Flat Rate Time	Defect Code	Symptom Code	Template ID	Failed Part Number
7491E3	Replace power seat slide (includes inspect and DTC clear	1.6hr	6XW00	UHA00	A24020A	81201-THR-A01

Skill Level: Repair Technician

INSPECTION PROCEDURE

1. Check if the SRS indicator is ON.
2. If the indicator is ON, do an All DTC check using the HDS.
3. If DTC U3000-49 (Internal Failure of the SRS Unit) is present, continue to step 4.
If DTCs other than U3000-49 are found, this service bulletin does not apply Continue with normal troubleshooting.
4. Slide the passenger's seat all the way forward and remove mounting bolts.

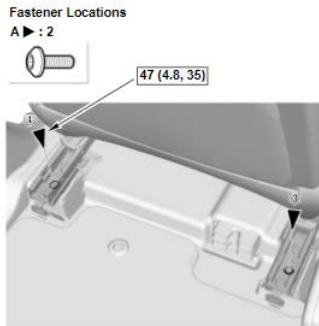

5. Slide the passenger's seat all the way rearward and remove the mounting bolts.

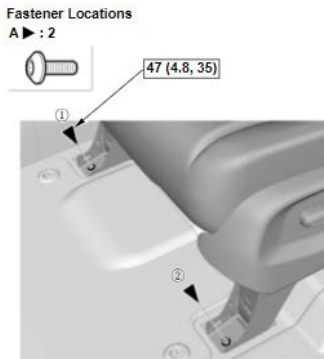

6. Remove the front bulkhead cover and air intake tube.

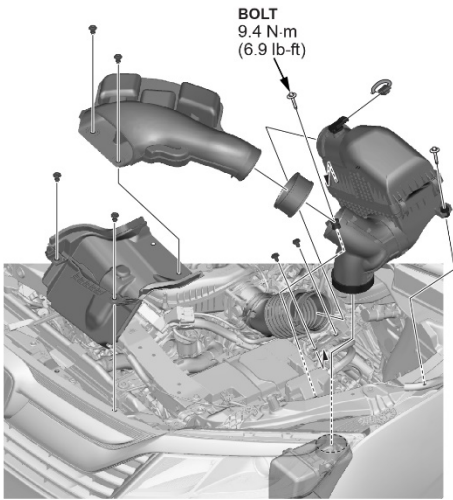

7. Disconnect the negative terminal of the 12V battery.

NOTE:

- To protect the 12-volt battery sensor connector from damage, do not hold it when removing the negative terminal.
- Do not disconnect the 12-volt battery sensor from the negative terminal.
- Wait at least **3 minutes** before starting work.

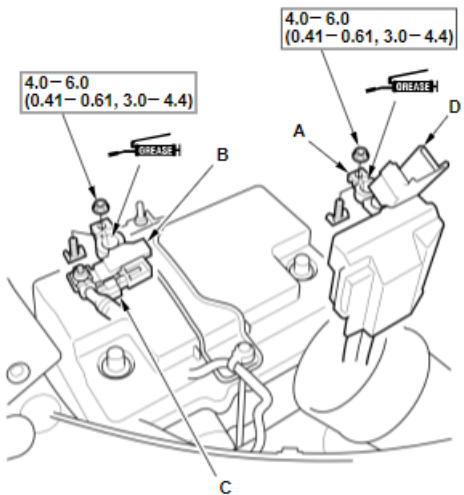

8. Tilt the seat back and disconnect the seat weight sensor connectors from the seat harness.

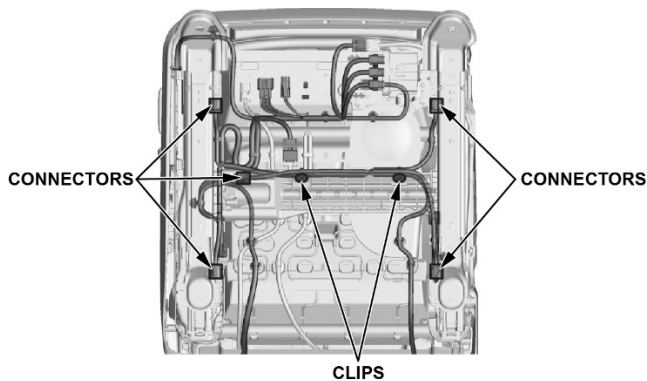

9. Connect the negative terminal of the 12-volt battery 5.0 N·m (3.7 lb-ft).

10. With the seat weight sensors disconnected, clear the DTC and do an **All DTC** check.

NOTE: Other new DTCs may be stored due to the seat weight sensors being unplugged. Disregard these new DTCs at this time.

- If DTC U3000-49 (Internal Failure of the SRS Unit) does not return, scan the QR code with a capable device and complete the form.

NOTE:

- This form must be filled out before parts can be ordered.
- If you can't scan the QR code, [\(Click HERE\)](#).



- If DTC U3000-49 does return, this service bulletin does not apply. Reconnect the SWS connectors and continue with normal troubleshooting.

REPAIR PROCEDURE

1. Disconnect the negative terminal of the 12V battery.

NOTE: To protect the 12-volt battery sensor connector from damage, do not hold it when removing the negative terminal.

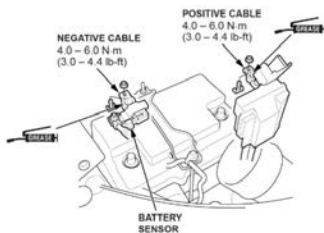

2. Disconnect the connectors.

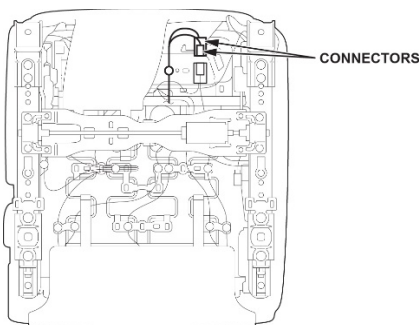

3. Remove the seat from the vehicle, and place it on a suitable clean surface, backrest down.

4. Remove the front and rear seat foot covers.

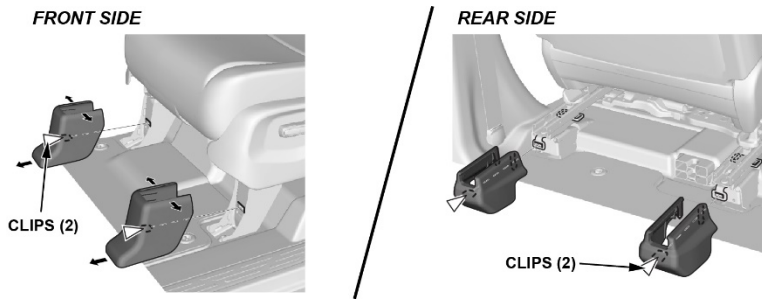

5. Remove the recline outer cover, then disconnect the connectors. (driver's side is shown)

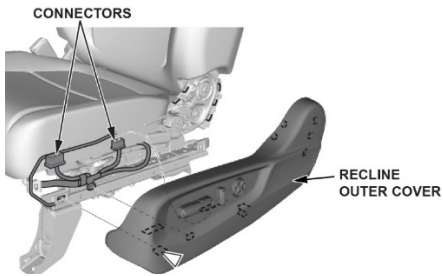

6. Remove front seat inner recline cover. (driver's side is shown)

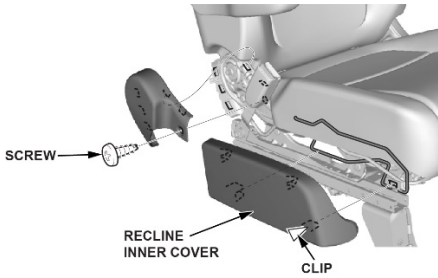

7. Release the straps from the lower cover.

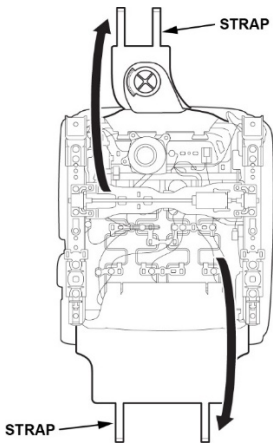

8. Unzip and raise the front seat backrest cover (A) to access the seat cushion.

NOTE: Removal of the backrest cover is not required.

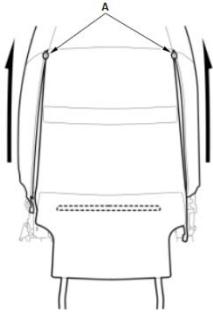

9. Remove the seat cushion cover:

1. Release the hooks.

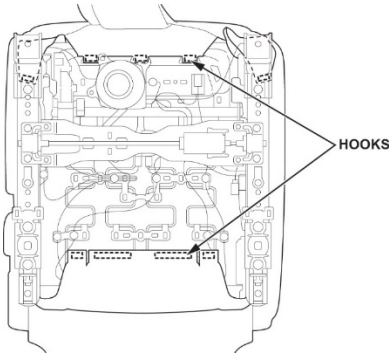

2. Release the hooks, then remove the front seat cushion cover/pad.

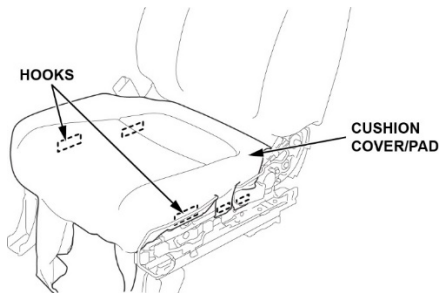

10. Remove harness clips from the lower seat spring and remove the lower seat spring.

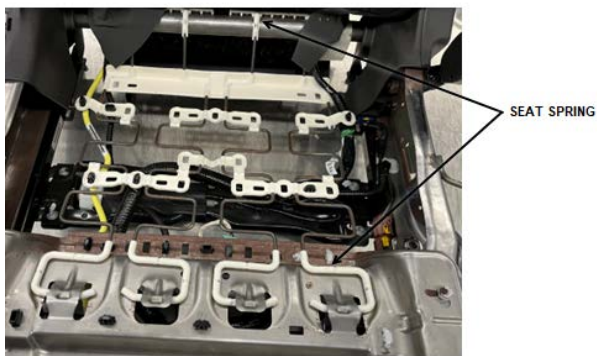

11. Remove both front seat inner recline covers

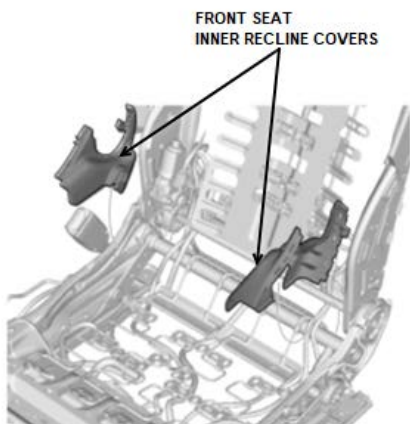

12. Remove the weight sensor nuts (A) and the mounting nuts (B), then remove the front passenger's seat rail/front passenger's weight sensors as an assembly (C).

NOTE: Note the color and location of the collars and the bushings during disassembly.

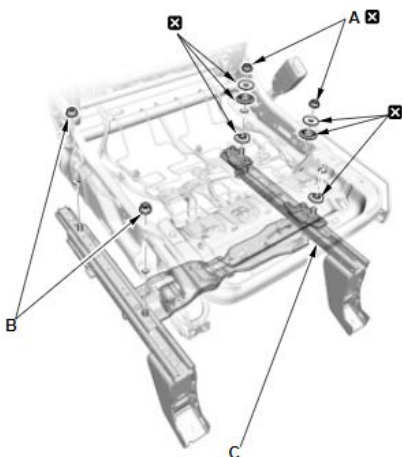

13. Install the front passenger's seat rail/front passenger's weight sensors as an assembly (A) to the seat frame as shown, and loosely tighten the new weight sensor nuts (B) and the mounting nuts (C).

NOTE: The bushings and collars can be identified by their color. Make sure to install the bushings and collars as shown.

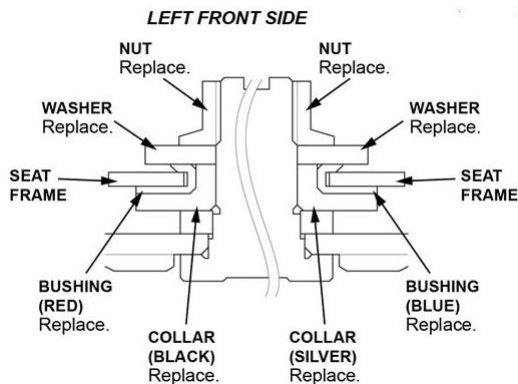
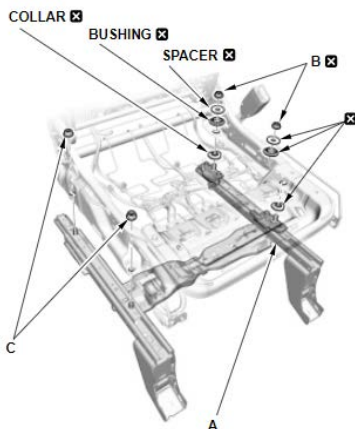

14. Tighten weight sensor nuts (A) and the mounting nuts (B) to the specified torque.

NOTE: Tighten the nuts in the numbered sequence shown.

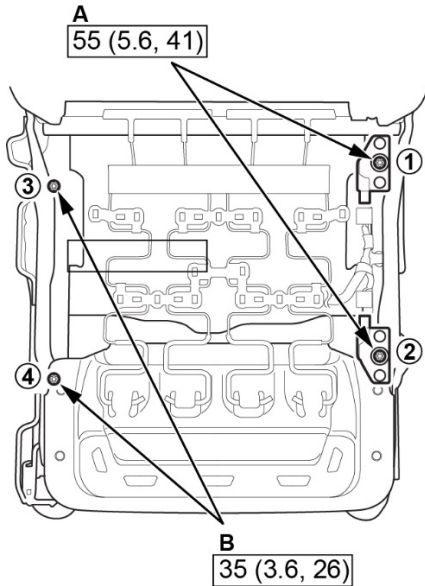

15. Do the seat weight sensor initialization.

1. Connect the i-HDS.
2. Front Passenger's Weight Sensor – Initialize.

NOTE:

- Before doing this procedure, clear the DTCs.
- Before doing this procedure, make sure the 12-volt battery is fully charged.
- Make sure the front passenger's seat and all components of the seat are correctly installed.
- Make sure nothing is on the front passenger's seat, including aftermarket seat covers or mats.
- Make sure there is nothing in the front passenger's seat-back pocket.
- Make sure the vehicle is on level ground.
- When you perform this procedure, the vehicle temperature must be between 16 - 34°C (61 - 93 °F).
- When the vehicle is exposed to intense cold or intense heat, move the vehicle inside, open the windows and sunroof (if equipped) and perform this procedure after one hour or more.
- Do not expose the front passenger's seat to sudden temperature changes.
- Do not use the A/C and the heater.
- Do not touch the front passenger's seat and keep the vehicle stationary during this procedure.
- Do not attach the seat belt tongue into the buckle.
- If possible, do all of the above procedures inside.

3. Position the front passenger's seat all the way rearward and lowermost (if equipped with the height adjuster), then adjust the seat-back to the forward most position.

NOTE: Do not move the seat from this position until the initialization is completed.

4. From SRS of the System Selection Menu, select SRS/SWS, then Adjustment. In the Adjustment, select SWS Initialization. Follow the prompts until the front passenger's weight sensor initialization has been completed.
5. From SRS of the System Selection Menu, select SRS/SWS, then Data List. In the Data List, select FRONT PASSENGER'S WEIGHT. The weight (T0) of the front passenger's seat is displayed by the HDS. Write this measurement down as "T0" on a piece of paper.

- If the reading on the HDS (T0) is within ± 0.35 kg (± 0.77 lbs), go to step 4
- If the reading on the HDS (T0) is at or not within ± 0.35 kg (± 0.77 lbs), do the following and repeat the procedure from step 1.
 - Confirm that the seat has no interference with surrounding components.
 - Remove the front passenger's weight sensors (If they were not reinstalled), reinstall them, then repeat this procedure from step 1.
- If after reinstalling the front passenger's weight sensors, the HDS (T0) is still at or not within ± 0.35 kg (± 0.77 lbs), replace the front passenger's weight sensors, then repeat this procedure from the beginning.

6. Prepare a weight between 10 kg (22 lbs) – 20 kg (44 lbs) then measure and note its actual weight (M) with a weight scale.

NOTE:

- The accuracy of the weight scale must be within 1 kg (2 lbs).
 - The weight must be uniform in shape and size to allow precise placement on the seat.
7. Precisely place the prepared weight on center of the front passenger's seat as shown.

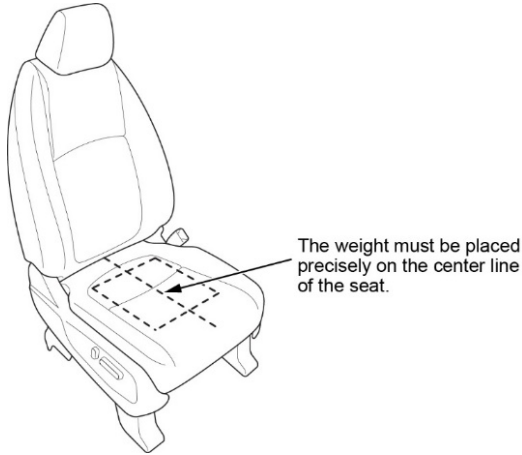

8. From the Data List, select FRONT PASSENGER'S WEIGHT. The weight (T) of the front passenger's seat is displayed by the HDS. Write this measurement down as "T" on a piece of paper.
9. Divide (M) by 2. Write this calculation as "M1" on a piece of paper.
10. Calculate the variance between (M1) and the HDS (T) with the following formula.

$$\text{Variance} = (T) - (M)$$

T: Weight measured by the HDS with the weight on the seat.

M: Weight measured by the weight scale

- If the variance is within ± 2.2 kg (± 4.9 lbs), initialization is complete. Go to step 9.
 - If the variance is at or not within ± 2.2 kg (± 4.9 lbs), do the following and repeat the procedure from step 1.
 - Confirm that the seat has no interference with surrounding components.
 - Confirm that the weight was placed precisely in the center of the seat.
 - Remove the front passenger's weight sensors, reinstall them, then repeat this procedure from step 1. If the variance is still at or not within ± 2.2 kg (± 4.9 lbs), replace the front passenger's weight sensors (if they were not replaced), then repeat this procedure from step 1.
11. Turn the vehicle to the OFF (LOCK) mode.