



INSTRUCTION TO SERVICE

ITS: 60913		January 25, 2024
SECTION:	260-Battery Compartment	
WRITTEN BY:	Troy Stutsky	
SUBJECT:	Version 2 drains in the ESS compartments will not deploy when required.	
ISSUE:	The dissolving powder washer in the version 2 drains is not working correctly.	
SUMMARY:	Inspect for version 2 drains and rework them to remove the washer and reinstall them. Mark the reworked drains with a green paint marker.	

ITS60913

Ref. NHTSA Recall No.	Ref. Transport Canada Recall No.
To be Determined	To be Determined

THIS ITS DOCUMENT SHOULD BE RETAINED AND REFERRED TO FOR FUTURE MAINTENANCE UNTIL THE NEW FLYER PARTS AND/OR SERVICE MANUAL IS UPDATED TO REFLECT WORK DONE AS A RESULT OF THIS DOCUMENT. ENSURE THAT THIS DOCUMENT IS AVAILABLE FOR PARTS AND MAINTENANCE STAFF GOING FORWARD.

PROCEDURE:

Section 1 – Initial Prep Work

1. Set the park brake and chock the wheels.
2. Turn the main battery disconnect and HV interlock switch to the “OFF” position.

⚠ WARNING: The work detailed in this ITS involves working near exposed High Voltage (HV) compartments, even after the bus has been locked out and tagged out. It is recommended that the service personnel be trained in NFI HV safety practices, such as those included in Appendix A – NFIL Spec 532295 - High Voltage Safety Guidelines & Procedures for New Flyer Battery Bus.

3. Perform the Lock Out Tag Out and De-Energizing procedures found in the Electrical System Section of the New Flyer Service Manual. Reference Figure 1 below.

⚠ WARNING: ENSURE MSD DUMMY PLUGS AND ARC FLASH GLOVES ARE AVAILABLE PRIOR TO STARTING ANY HV DISASSEMBLY

🔑 NOTE: Use commercially available lock out equipment and tags being sure to follow any local laws or workplace procedures.

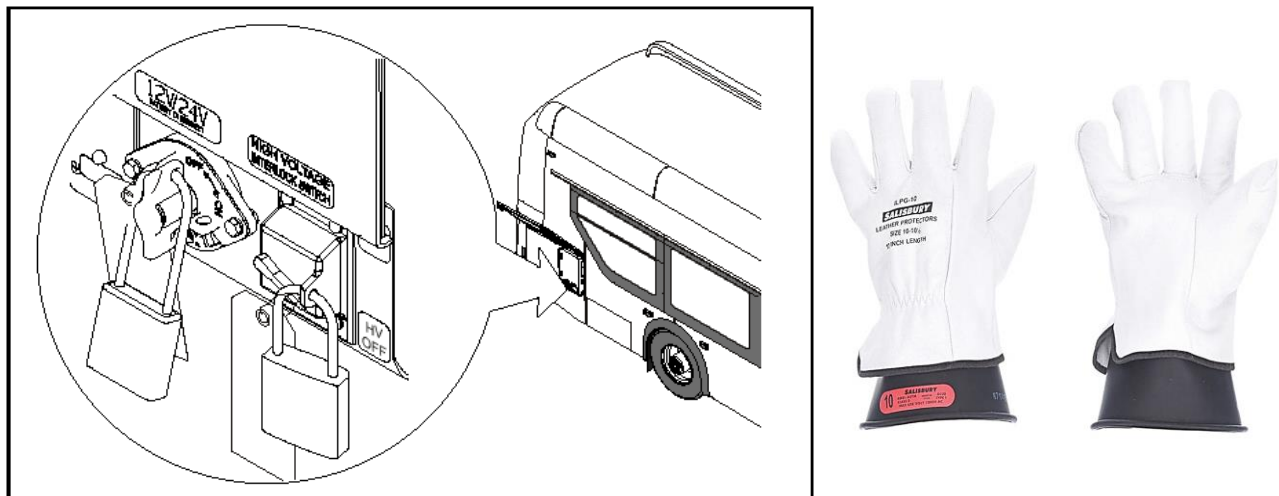

Figure 1: HV and LV Disconnect Switch Location and Arc Flash Glove Reference

⚠ WARNING: ARC FLASH GLOVES MUST BE USED ANYTIME THE ESS HAS AN UNCOVERED HOLE

Section 2 – ESS Access

4. Gain access to the rooftop ESS enclosures. Ensure that appropriate fall protection PPE is used and available for the duration of the work.

Ensure appropriate safety procedures are followed for the duration of the work.

5. Open the rear access door to expose the drain ports (some components removed for clarity). You will need special torque tools to access the ports on the rear ESS.

NOTE: At this point access to the ESS compartments is available.

6. Inspect the part number that is on the top of the ESS drain cartridges.

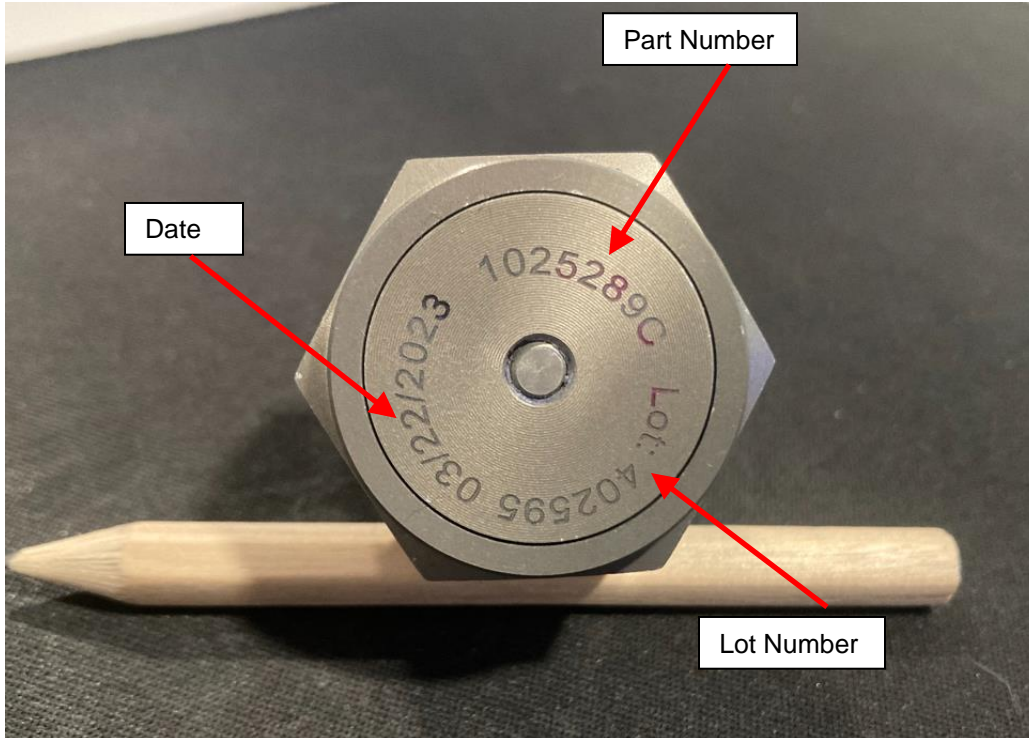

Figure 2: Part Number Identification

- a. If the part number on the drain cartridge is 1025289 **AND** has a bobbin lot code of 402595, 402648 or 402656, replace the drain cartridge with a new one. Install the new ESS drain cartridges and torque to 40Ft/Lbs. Mark the top of the new ESS drain cartridge with a “green” paint marker to identify the drain has been replaced.



Figure 3: Mark with a Green Paint Marker

- b. If the part number on the drain cartridge is 1025289 and has any other bobbin lot code than the ones mentioned above, leave this drain installed and mark the top of the ESS drain cartridge with a “green” paint marker to identify the drain has been inspected and is good.
- c. If the part number on the drain cartridge is 1050112 **WITH A REV C MARKED ON IT**, leave this drain installed and mark the top of the ESS drain cartridge with a “green” paint marker to identify the drain has been inspected and is good.
- d. If the part number on the drain cartridge starts with 1044209 or 1050112 they will need to be reworked. Remove the drain. Use a pick to loosen the black washer. Cut the black washer so it can be fully removed from the drain and discarded. Reinstall the reworked ESS drain cartridges and torque to 40Ft/Lbs. Mark the top of the reworked ESS drain cartridge with a “green” paint marker to identify the drain has been reworked.



Figure 3: Remove Black Washer from Drain Cartridge

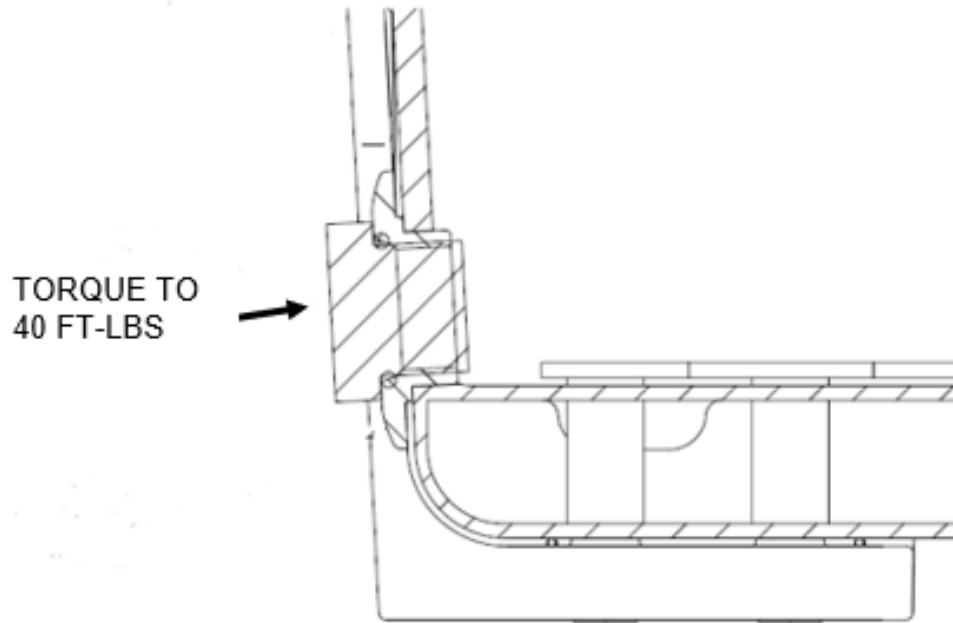

Figure 4: Torque ESS Drain Cartridges – USE ARC FLASH GLOVES

7. Clean workspace and return coach to revenue service condition.



LABOUR ESTIMATE				
	Operation	Number of Technician(s)	Hours	Labor Time T X HR
1	Inspect for version 2 drains and rework them as required per the instruction. Mark the reworked drains with a green paint marker.	1	1.25	1.25

TOOL KIT					
Item	Part Number	Description	Qty.	Units	Notes
1	6495077	TOOL-15 DEGREE OFFSET BOX END	1	EA	Part of Tool Kit
2	6495078	TOOL-1/4 DRIVE RATCHET	1	EA	
3	6495079	TOOL-40FT LBS PRESET TORQUE WRENCH	1	EA	

Appendix A – NFIL Spec 532295 - High Voltage Safety Guidelines & Procedures for New Flyer Battery Bus

The following provides general guidelines in relation to safety and best practices when completing installation or servicing work on any New Flyer battery bus vehicle platform.

This document is not meant to supersede the actual released installation and assembly drawings and where conflicts arise, the released engineering drawings take precedence.



Introduction

The utmost concern, while working with High Voltage (HV) systems, is the safety of yourself, other personnel, and the potential of damage to property. To minimize these risks, it is crucial to be properly trained and always maintain a very alert, questioning, and disciplined attitude without fail. As soon as your guard is lowered, then the potential of an accident is probable that can hurt or kill yourself or someone else and possibly damage property.

What is High Voltage (HV)?

Any form of voltage that is greater than 50 volts if the person's skin at the electrical contact points is not compromised and not wet.



Equipment Required

The following equipment shall be required:

Digital Multimeter (DMM), 1000-volt Category III, 600 volt Category IV,
10Megohm impedance or greater with insulated case or rubber holster
Clamp-on current probe, 1000-volt Category III, 600 volt Category IV
High Pot Tester (Hi-Pot)

Phase rotation meter

Personal Protection Equipment (PPE) appropriate for 700volt DC & 230
volt AC with Class 00 or higher HV gloves with compatible leather over
gloves. Appropriate safety glasses as well as the face shield. The PPE
shall also meet the required Arc Flash & Arc Blast requirements. Before
use, inspect the PPE in accordance with this guideline.

Adequate lighting

HV insulated mat

Two fused HV clip leads 10 inches long

Safety barricade with warning lights & "Danger High Voltage" signs

Belt tool pouch (use only to carry small components up/down a ladder)

Torque Screwdriver set

Imperial torque nut driver set

Metric torque nut driver set

Equipment Calibration

All test equipment must be within their calibration interval and recorded such with the respective serial numbers.

These records must be available to the Checker.



Personnel Requirement

Only trained personnel shall supervise and perform High Voltage system testing, checkout, and troubleshooting. Two personnel (one called the Checker & the other called Monitor/Recorder) shall perform Checkout Procedures, together, to ensure safety of themselves, others nearby & for the protection of vehicle & property. Refresher training shall be provided to these personnel on a regular basis and when new systems are to be checked by them. The training of the personnel shall consist of:

- HV & low voltage basics, intermediate & advanced electricity
- HV & low voltage electrical systems of the vehicle
- Shop safety practices & procedures
- First aide including CPR & the use of the shop defibrillator
- How to release a victim that can't let go HV
- Quickest method of shutting down HV
- Firefighting and emergency procedures
- HV & arc flash safety
- Organized & tidy placement of equipment & tools allowing for unrestricted movement
- Operation of Hi-pot

To ensure effectiveness of training, exams of the trained material shall be required with a high passing mark of at least 80% and a retraining of the missed 20 % on a one-to-one basis.

Checker Function

(Caution: The Checker must not have any health conditions that can be exacerbated when startled and must not have any electronic implants.)

- Directed by the Monitor/Recorder
- Performs all preparations & checks
- Wears PPE as specified by the Checkout Procedure
- Performs all restorations

Vehicle Inspection

It is necessary that the vehicle to be checked out, first be visually inspected of all systems, workmanship and with special attention to ensuring there is no HV cable or equipment damage or chafing.



High Voltage Checkout Preparation

- (1) The scope of the work must be accurately defined such as a Checkout Procedure that requires systematic steps with sign offs. Before a Checkout is performed, the Supervisor, Checker and Monitor/Recorder must conduct a briefing of what shall transpire, identify potential hazards, resist pressures of “is it done yet?”, anticipate problems and question possible events. If unexpected electrical hazard or fault occurs, during any time of the Checkout, it must be immediately reported to the supervisor. After the Checkout is completed, the same group should review the results and processes and make proposed modifications to the procedures if required.
- (2) Install Safety barricade with warning lights & signs indicating "Danger High Voltage" around the vehicle perimeter and ensure no personnel are within the fenced perimeter during the checkout procedure.
- (3) It shall always be the goal to check the systems as much as possible with all HV power OFF and Locked Out/Tagged Out and proven as de-energized by voltage measurement using the DMM. The functionality of the DMM must be proved before and after the verification of no HV present. Then, if possible, the HV systems should be challenged by trying to energize them while checking that no HV appears.
- (4) When it is necessary to perform tests of HV systems with the power ON, then the Working Live procedure must be followed.
- (5) The test personnel shall always rehearse the actions required in case of any possible accident scenarios.
- (6) Before beginning the Checkout Procedure, the test personnel shall remove all their jewelry (including pierced ones), watches and any electrically conductive objects on them.

PPE Requirements

The PPE voltage class, Arc Flash and Arc Blast rating shall be compatible with the voltage and Arc Flash capability of the systems being tested. Appropriate leather glove protectors shall be worn over the HV rubber gloves.

PPE Care & Testing

Rubber insulated PPE shall be periodically cleaned and tested in accordance with 29 CFR 1910.137 and the appropriate ANSI/ASTM standards. HV gloves, sleeves and mats shall be tested every 6 months. PPE apparel shall be cleaned and maintained in accordance with the manufacturer’s instructions. A record of the PPE testing shall be maintained and available to the users.

PPE Inspection

Inspect PPE equipment, before use, for any degradation or damage and ensure that the HV gloves have been tested every 6 months. Also perform an air pressure test on the HV gloves before and after each use. If during PPE use a potential damaging incident occurred to the PPE, stop further testing and inspect the PPE. If at any time the PPE is defective, reject it, and obtain an accepted one.

PPE Storage

PPE apparel should be stored lying flat, undistorted, right-side out and not folded in protective containers. The HV mats can be rolled with an inside diameter greater than 2 inches.

Rubber HV gloves should be stored in cool, dark, dry, and free from damaging chemicals or vapors. The glove cuffs should face downwards, without folding, in the appropriate glove bag and hung vertically.

Insulated Tools

Insulated tools should be visually inspected for insulation damage before and after each session of use.

Lockout/Tagout Procedure

The Lockout/Tagout procedure should be followed that is specified in the respective checkout procedure. When removing the lock and tag:

- (1) The locks and tags shall be removed by the installer of them or under her/his supervision.
- (2) If the installer of the locks and tags is not available, then her/his supervisor:
 - (a) Ensures that the installer of the locks and tags is not in the facility
 - (b) Contacts the installer to inform her/him that the locks and tags will be removed
 - (c) Reminds the installer of the lock and tag removal when she/he resumes work

Stored Energy

Personnel must always remember the characteristics of stored energy devices such as capacitors and batteries and when energy is available from.

Working Live

To maximize safety, it is always important to perform the maximum amount of HV checkout in the de-energized state.

When it is necessary to work with HV equipment while energized or to verify whether HV is present, the utmost care and safety procedures must be utilized including:

- (1) Wearing appropriate PPE with protector gloves over top of the HV rubber gloves
- (2) Ensure all personnel, except the Checker and Monitor/Recorder, are clear of the vehicle
- (3) Kneeling or standing on HV insulated mat



Energizing & De-energizing Procedure

It is critical that before any HV system is energized that a visual check be performed to ensure that all possible HV compartments are closed and there is no debris, tools or test equipment lying on HV terminations. If there is a certain sequence of energizing and de-energizing the HV system, then all personnel involved must be trained in this sequence. (CAUTION: Never try to connect or disconnect circuit components such as cables, fuses, connectors, etc. while there is current flowing in the circuit.)

Electrical Injuries

Electrical injuries should be immediately reported to the first aide personnel and the supervisor. Other than electrostatic shocks, even non-injurious electrical shocks should be reported to the supervisor. These should be immediately investigated and documented to determine the cause and prevent the occurrence in the future.