



# GO-ES SpaceSaver Foldaway Service Instructions

---

20240130

© Freedman Seating Company. All rights reserved. Information contained in this document is indicative only. No representation or warranty is given or should be relied on that it is complete or correct or will apply to any particular project. This will depend on the technical and commercial circumstances. It is provided without liability and is subject to change without notice. Reproduction, use or disclosure to third parties, without express written authorization, is strictly prohibited.

# Overview

---

Inspection

Rework

© Freedman Seating Company. All rights reserved. Information contained in this document is indicative only. No representation or warranty is given or should be relied on that it is complete or correct or will apply to any particular project. This will depend on the technical and commercial circumstances. It is provided without liability and is subject to change without notice. Reproduction, use or disclosure to third parties, without express written authorization, is strictly prohibited.

# Inspection Step 1

Bring seat back cushion from stowed position (seat back cushion is folded down against seat cushion) to first engagement point of the back lock (most upright position of the seat back cushion)

Add a piece of tape on the dump cover shroud so that it touches the handle

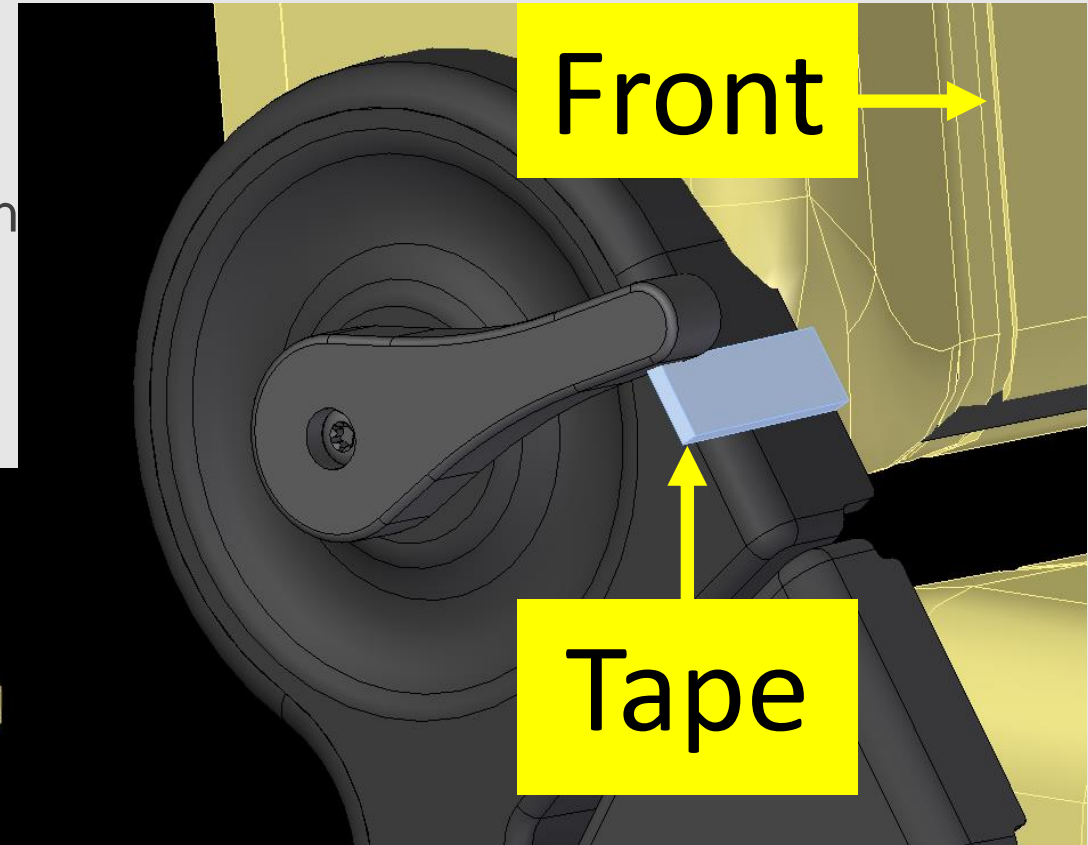

© Freedman Seating Company. All rights reserved. Information contained in this document is indicative only. No representation or warranty is given or should be relied on that it is complete or correct or will apply to any particular project. This will depend on the technical and commercial circumstances. It is provided without liability and is subject to change without notice. Reproduction, use or disclosure to third parties, without express written authorization, is strictly prohibited.

# Inspection Step 2

Pull the handle to release the seat back and actuate the back into the most reclined position

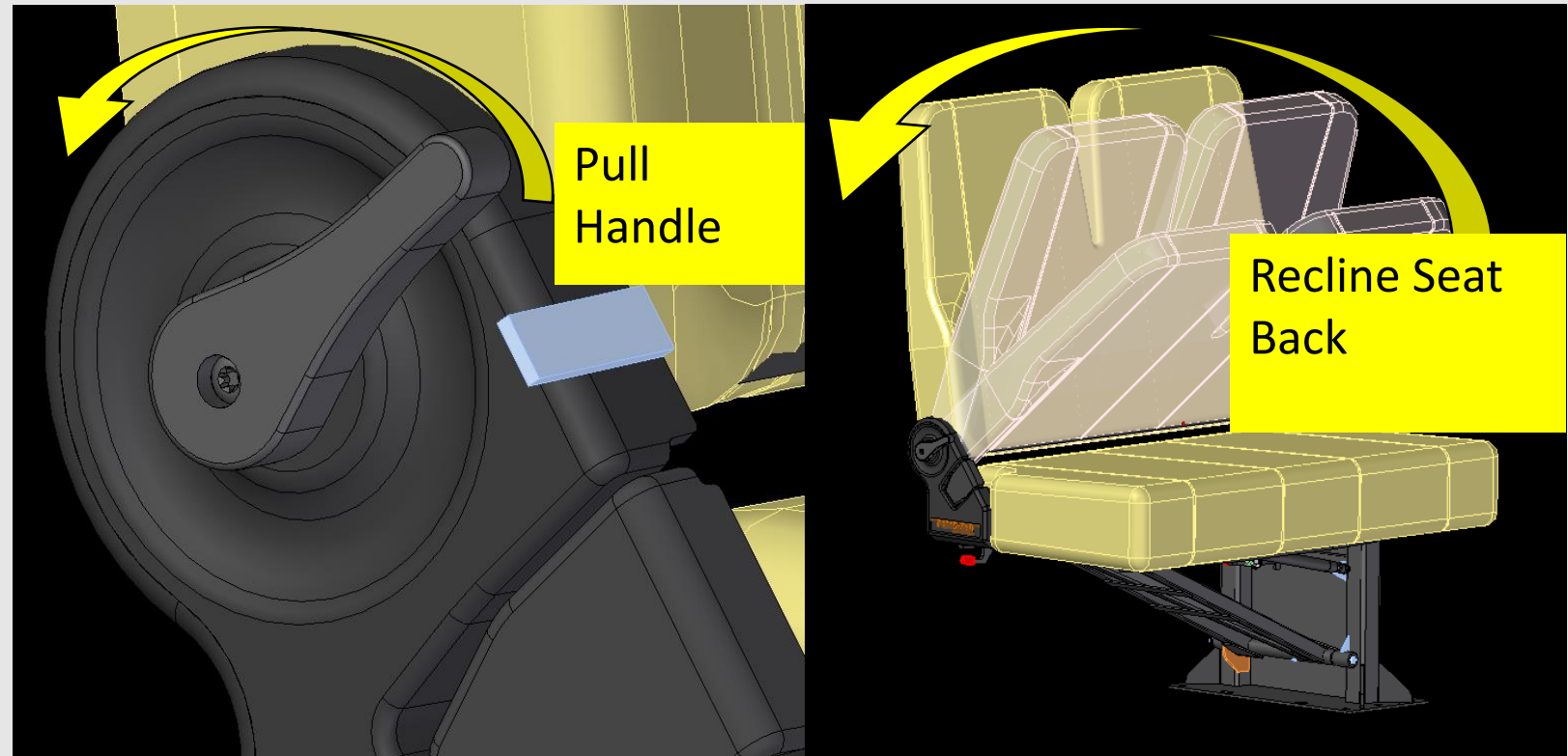

© Freedman Seating Company. All rights reserved. Information contained in this document is indicative only. No representation or warranty is given or should be relied on that it is complete or correct or will apply to any particular project. This will depend on the technical and commercial circumstances. It is provided without liability and is subject to change without notice. Reproduction, use or disclosure to third parties, without express written authorization, is strictly prohibited.

# Inspection Step 3

Release handle and pull seat back forward

If handle returns back to original position, no additional work needed

If handle does not return back to the original position then seat will need to be reworked

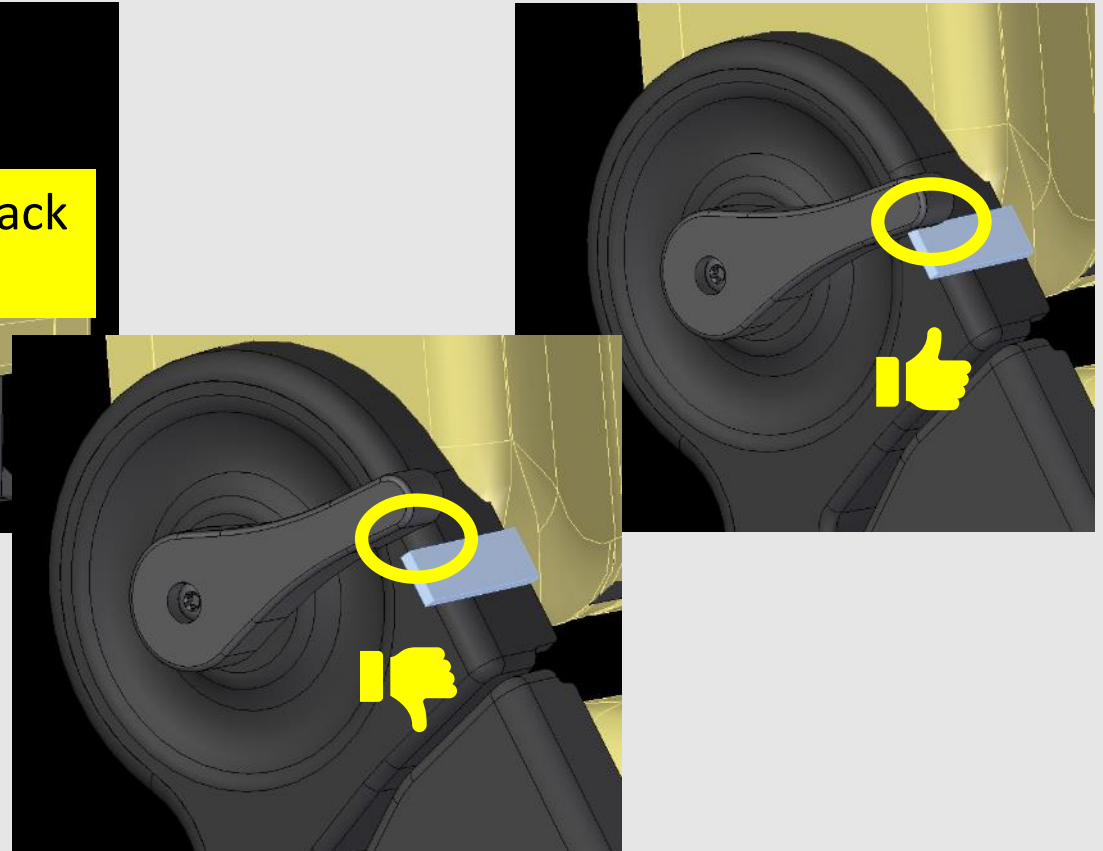
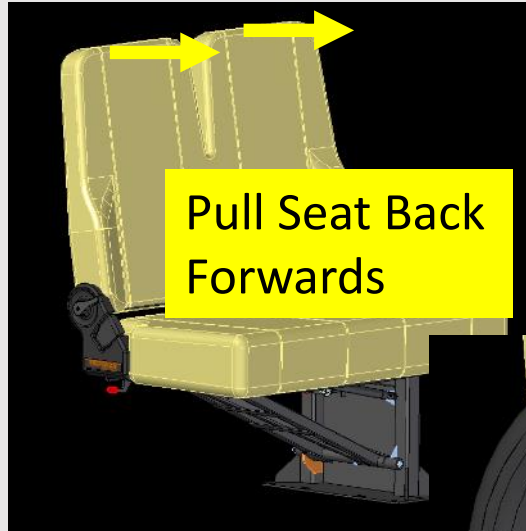

© Freedman Seating Company. All rights reserved. Information contained in this document is indicative only. No representation or warranty is given or should be relied on that it is complete or correct or will apply to any particular project. This will depend on the technical and commercial circumstances. It is provided without liability and is subject to change without notice. Reproduction, use or disclosure to third parties, without express written authorization, is strictly prohibited.

# Rework Step 4

Fold the seat back down to the cushion to expose the stop brackets

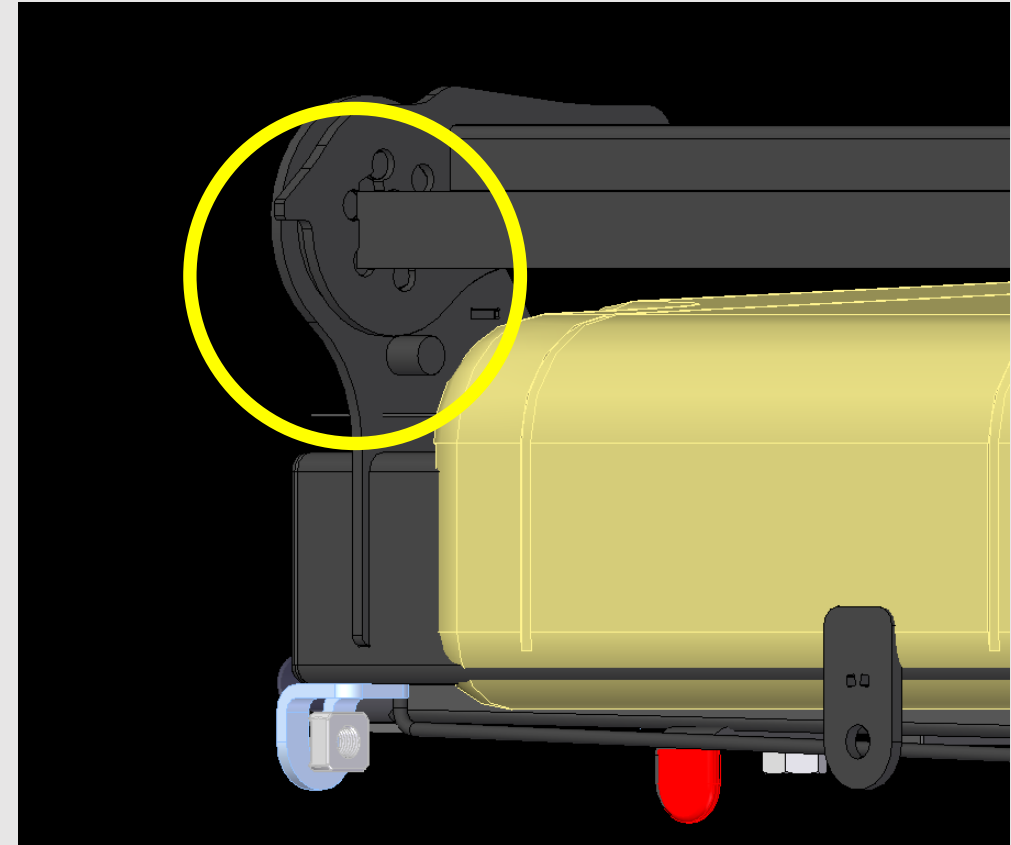

© Freedman Seating Company. All rights reserved. Information contained in this document is indicative only. No representation or warranty is given or should be relied on that it is complete or correct or will apply to any particular project. This will depend on the technical and commercial circumstances. It is provided without liability and is subject to change without notice. Reproduction, use or disclosure to third parties, without express written authorization, is strictly prohibited.

# Rework Step 5

On the stop bracket adjacent to pin, use a Dynafile or similar tool to grind off up to 1/32" off of the face of the stop

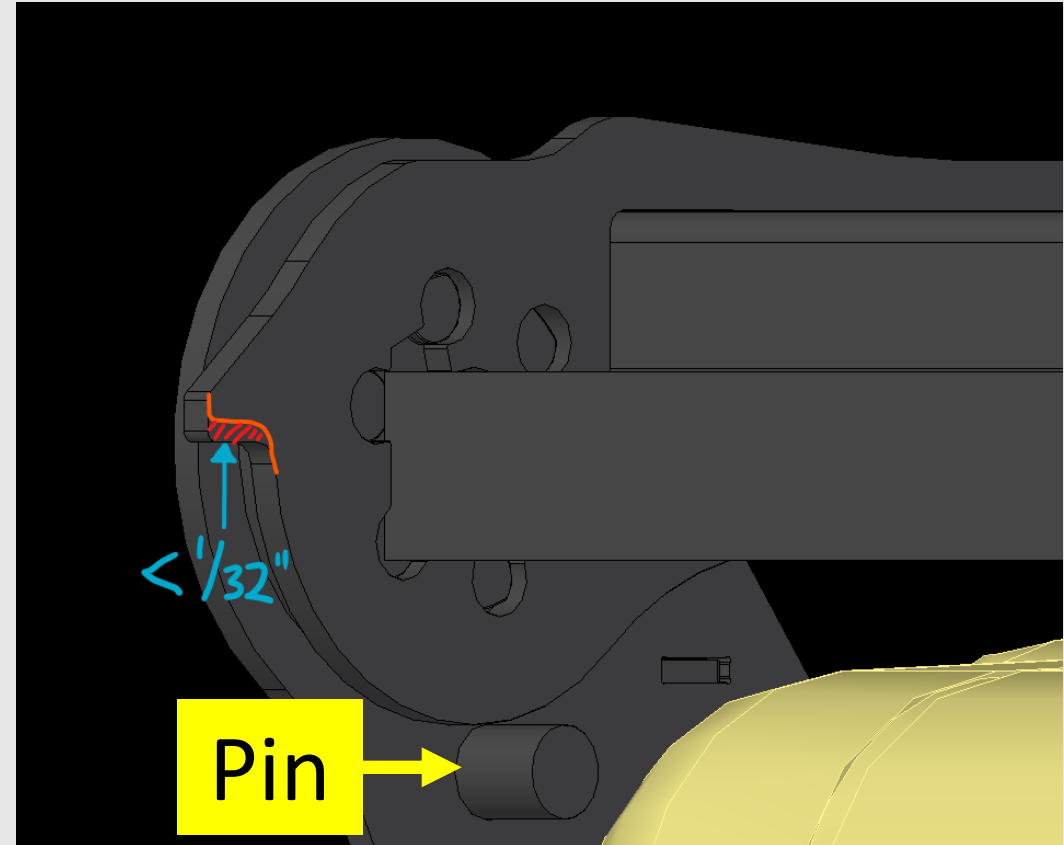

© Freedman Seating Company. All rights reserved. Information contained in this document is indicative only. No representation or warranty is given or should be relied on that it is complete or correct or will apply to any particular project. This will depend on the technical and commercial circumstances. It is provided without liability and is subject to change without notice. Reproduction, use or disclosure to third parties, without express written authorization, is strictly prohibited.

# Rework and Final Inspection Step 6

---

Repeat step 3 to recheck handle and if necessary repeat steps 4-5 to get handle to appropriately lock

© Freedman Seating Company. All rights reserved. Information contained in this document is indicative only. No representation or warranty is given or should be relied on that it is complete or correct or will apply to any particular project. This will depend on the technical and commercial circumstances. It is provided without liability and is subject to change without notice. Reproduction, use or disclosure to third parties, without express written authorization, is strictly prohibited.





# Thank you

---

**Will O'Connor**

Lead Engineer – New Product Design

(773)-524-2440x321 / [Will.OConnor@FreedmanSeating.com](mailto:Will.OConnor@FreedmanSeating.com)

© Freedman Seating Company. All rights reserved. Information contained in this document is indicative only. No representation or warranty is given or should be relied on that it is complete or correct or will apply to any particular project. This will depend on the technical and commercial circumstances. It is provided without liability and is subject to change without notice. Reproduction, use or disclosure to third parties, without express written authorization, is strictly prohibited.