

Bulletin #: AS-13-24B		<input type="checkbox"/> Take Note <input checked="" type="checkbox"/> Take Action	
<input type="checkbox"/> Retail Operator	<input type="checkbox"/> Sales Pre-Owned	<input checked="" type="checkbox"/> Business Manager	<input checked="" type="checkbox"/> Parts & Accessories
<input checked="" type="checkbox"/> General Manager	<input type="checkbox"/> Sales New Bike	<input checked="" type="checkbox"/> Service	<input type="checkbox"/> Administration
Name:		Phone Number:	
Title:		Source: Parts Logistics	
Email:			
Date: 03/21/2024		Supersedes: -AS-13-24A	

TEC617 VARIO TOPCASE

RECALL 24E-020 HAS BEEN ISSUED FOR THE VARIO TOP CASE FOR R 1300 GS

Description	Part Number
Vario Topcase	77 43 9 443 542

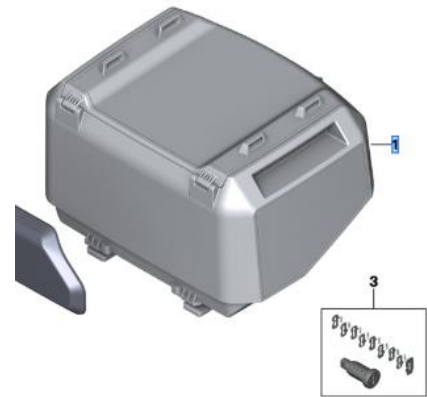

UPDATE: RETURN SHIPPING REMOVED

We are currently evaluating whether the Vario Topcase repair can be performed at the dealer level based on new information. During this evaluation period, we kindly request that you refrain from shipping any cases back to the RDC's.

OVERVIEW

BMW is announcing a delivery stop for the Vario Top Case for the R 1300 GS for top cases produced up to 02/16/2024, part number 77 43 9 443 542.

This safety recall involves the dealer accessory top case. The locking flap of the top case (fastening the top case to the luggage carrier of the motorcycle) may appear to be securely closed by the user. However, in this condition, the key can be removed. If this occurred, the top case would not be securely fastened to the motorcycle, could detach, and become a hazard for road users. No Vario Topcase for the R 1300 GS should be installed on the motorcycle.

MAKE LIFE A RIDE



**BMW
MOTORRAD**

NHTSA STATEMENT

Please be reminded that it is a violation of federal law (The Safety Act) for you to sell, lease or deliver any new motorcycle covered by this notification until the recall repair has been performed. This means that dealers may not legally deliver new motorcycles to consumers until they are fixed or use/sell replacement equipment/parts subject to this recall. Note also that substantial civil penalties apply to violations of the Safety Act. Also, you should not sell, lease or deliver any used motorcycles subject to a safety recall until the repair is completed. Please follow any special instructions that we provide to you for the return or disposition of recall parts.

MORE DETAILS

- TEC617 is valid from February 14, 2024, through April 30, 2024. The deadline for filing a claim under TEC617 is April 30, 2024.

<p style="text-align: center;">Affected Parts (NOT OK)</p> <p style="text-align: center;">R 1300 GS for top cases produced up to 02/16/2024 Part number 77 43 9 443 542.</p>	<p style="text-align: center;">Non Affected Parts (OK)</p> <p style="text-align: center;">Fix/New Part TBD</p>
---	--

MORE QUESTIONS?

Aftersales Business Development Manager		
Material Planning and Parts Logistics Analyst		

MAKE LIFE A RIDE