



IMPORTANT SAFETY RECALL NHTSA Recall No. 24V-637

Date: October 18, 2024

«Address_1_»
«Address_2»
«City», «State» «Zip»

«F10»

This notice applies to your vehicles, VIN's: See Attached List

Re: Insufficient Welds on Support Gear Brace Mounts Recall

«TO»

This notice is being sent in accordance with the National Traffic Motor Vehicle Safety Act.

Great Dane LLC has decided that a defect, which relates to motor vehicle safety, exists in certain 2025 Everest SS refrigerated trailers. The trailers were manufactured in our Wayne NE manufacturing facility, where the welds attaching the support gear brace mounts to the support gear are insufficient.

Trailers with insufficient welds on their support gear bracing mounts may suffer a collapse of the support gear while parked and utilizing the support gear without a tractor attached, or safety stands in place. A collapse of the trailer support gear may lead to damage, increasing the risk of injury or death. Great Dane has produced a field inspection and repair procedure to address this possible defect. Great Dane will pay authorized repair agents to inspect support gear bracing mount welds for proper penetration as well as conformity to design print. Any welds found to be insufficient will be ground out and rewelded to conform to design print. These repairs will be covered under Great Dane's warranty program. It is estimated that this inspection/repair will take 60 minutes per trailer.

If you had this repair performed before you received this letter, you may be eligible to receive reimbursement for the cost of obtaining a pre-notification remedy of the problem associated with this recall. For more information contact Great Dane Customer Service at (877) 369-3493.



Federal regulations require that any vehicle lessor receiving this recall notice must forward a copy of this notice to the lessee within ten days.

If you conclude that Great Dane LLC has not enabled you to remedy this condition without charge and/or in a reasonable time, a complaint may be submitted to the:

Administrator
National Highway Traffic Safety Administration
1200 New Jersey Avenue SE
Washington, DC 20590

-or-

Call the toll-free Vehicle Safety Hotline: 1-888-327-4236; (TTY: 800-424-9153) or go to <http://www.safercar.gov>)

We regret any inconvenience that this situation may have caused. Great Dane LLC wants to assure you that we are concerned for customer safety and your continued satisfaction with our products.

Sincerely,



James M Brown
Senior Manager, Customer Service/Warranty



GREAT DANE

LG Rework Instructions

All required Great Dane PPE and safety rules will be adhered to during inspection and rework.

1. Inspection

A visual inspection of welds may be performed by a trained welder with proper inspection tools to recognize correct weld leg length and weld size. (oversize welds will be acceptable, leg centerline lengths that are not equal will not be)

- Recommend .19 Single-J Groove weld be applied on back side of LG ears to provide additional reinforcement.
- Drawing 10309047018 Detail Excerpts
- PDF AWS D1.1 Standards Fillet Weld to Plate Thickness

2. Consumables

- Welding - .045 ER70S GMAW wire
- Shielding Gas 95-5 or 90-10 Argon/O₂ (Ar/CO₂ substitute),
- Grinding wheels/flap disc
- Cold galvanize and black paint.
- Additional LG tabs, trapezoids, fasteners (carbon steel/galvanized) K-braces, Support Braces

3. Equipment

- 350 Amp portable welding machine capable of GMAW Pulse process.
- Plasma Arc (not necessary, but could speed repair process)
- JIG for proper placement of trapezoid/Tabs
- Enclosed garage bay w/ air, electricity.
- Portable jack/jacks to support trailer during repair (jacks must be utilized any time where LG support braces are missing, damaged/removed)
- Truck may be utilized in event jacks are not available, LOTO of truck must be enforced. (dictated by safety)
- Grinders
- Impacts
- Hammers
- Clamps
- Torque Wrenches
- Combination Wrenches
- Torpedo Level
- Tape Measure

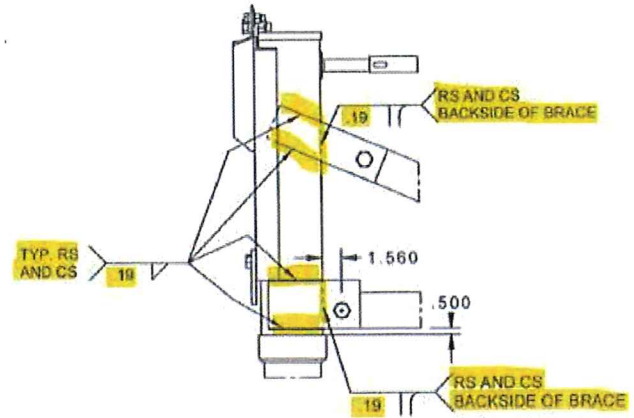
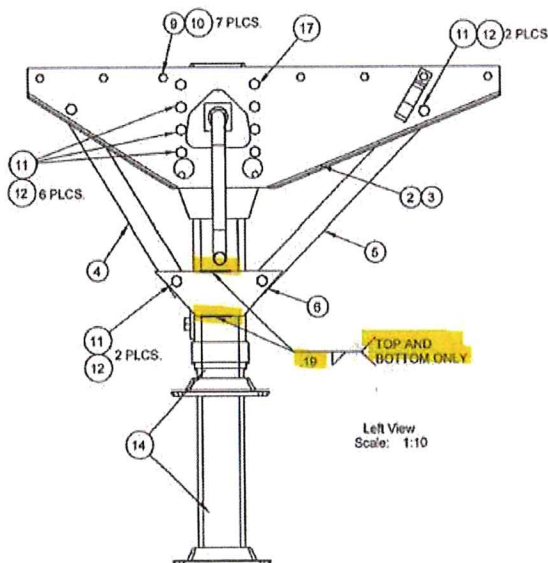

4. Rework Preparation for Failed Trapezoid/Tabs

- Trailer brakes set; support jacks placed.
- Damaged components removed, visual inspection to determine if reusable. All fasteners will be discarded and replaced.
- Reusable components stored for installation at later time. i.e. K-Brace, trapezoid/tabs
- All bad welds ground flush w/ LG base material
- Reusable trapezoids/tabs ground to remove old weld and preparation for re-installation.
- Location JIG utilized for proper placement of components to be welded.
- Components tacked in place.
- Welds completed IAW Great Dane drawing for customer.

5. Inspection of Identified Units

- Trailer LG trapezoid/tab welds will be inspected, determination made as to LG weld integrity.
- Trailer brakes set; support jacks placed.
- Suspect welds will have a groove made the length of the current weld on the trapezoid/tab side.
- .25 fillet weld performed in prepared site ensuring proper fusion and tie-in of old weld.

6. Recommended Weld Parameters

- Pulse-
- Short circuit transfer-

Table 7.6

Camber Tolerance for Girders without a Designed Concrete Haunch (See 7.22.4)

Camber Tolerance (in inches)					
a/S	0.1	0.2	0.3	0.4	0.5
Span ≥ 100 ft	1/4	1/2	5/8	3/4	3/4
Span < 100 ft	1/8	1/4	5/16	3/8	3/8

Camber Tolerance (in millimeters)					
a/S	0.1	0.2	0.3	0.4	0.5
Span ≥ 30 m	7	13	17	19	20
Span < 30 m	4	6	8	10	10

Table 7.7

Minimum Fillet Weld Sizes (See 7.13)

Base Metal Thickness (T) ^a		Minimum Size of Fillet Weld ^b	
in	mm	in	mm
T ≤ 1/4	T ≤ 6	1/8 ^c	3 ^c
1/4 < T ≤ 1/2	6 < T ≤ 12	3/16	5
1/2 < T ≤ 3/4	12 < T ≤ 20	1/4	6
3/4 < T	20 < T	5/16	8

- For nonlow-hydrogen processes without preheat calculated in conformance with 6.8.4, T equals thickness of the thicker part joined; single-pass welds shall be used. For nonlow-hydrogen processes using procedures established to prevent cracking in conformance with 6.8.4 and for low-hydrogen processes, T equals thickness of the thinner part joined; single-pass requirement shall not apply
- Except that the weld size need not exceed the thickness of the thinner part joined.
- Minimum size for cyclically loaded structures shall be 3/16 in [5 mm].