



Recall Information Bulletin

No: C10131 Issued: 1/17/2025

NHTSA No: 24V932

Transport Canada No: N/A

SUBJECT:

Safety Recall C10131 – Vehicle Control Unit Circuit

MODELS:

FEC7K (E16L/E16M), FEC9K (E18L/E18M)

VEHICLES INVOLVED:

Certain 2024 model year FEC7K and FEC9K trucks.

A list of vehicles your Dealership has sold that require this Recall can be found on the “Open Campaigns” list supplied by RIZON. Some individual vehicles described above may not need the Recall as the repairs may have already been performed. Always check the vehicle information section in DealerPro, or they may contact Rizon Warranty at rizonwarranty@rizontruck.us to verify that the VIN requires this Safety Recall.

Important note: It is a violation of Federal law for a dealer to deliver a new or used motor vehicle covered by this Recall Information Bulletin, under a sale or lease, until the Safety Recall has been completed.

OWNER NOTIFICATION:

Owners of affected vehicles will be notified by mail.

CONDITION:

Mitsubishi Fuso Truck of America, Inc. has decided that a defect, which relates to motor vehicle safety, exists in the vehicle control unit (VCU) circuit on certain 2024 model year FEC7K (E16L/E16M) and FEC9K (E18L/E18M) RIZON trucks. An error in circuit design allows a continuous overcurrent flow through the C6 connector. Vehicles that have been operated for more than 12,000 miles may experience discoloration and damage of the connector pin due to overcurrent flowing through the housing. In the worst case, the vehicle control unit may malfunction, decelerating the vehicle and preventing further acceleration causing a crash without warning.

MODIFICATION:

A subharness will be installed in all affected vehicles. The connector and pins will be inspected, and discolored or deformed components will be replaced.

PARTS REQUIRED:

1) LT227A01EX Subharness, 0-1) LT227A03EX Connector housing, 0-1) LT227A04EX Terminals and splices

RECALL CLAIM SUBMITTAL:

Upon completion of a recall or field fix repair, a warranty claim must be submitted to Rizon US through the DealerPro system or manually through our interim process. It is important to use the appropriate claim type, e.g. Recall or Field Fix and Recall/Field Fix number. The claim will be processed by Rizon and reimbursement will be completed using the reimbursement schedule used for your standard warranty claims. If you need support submitting a claim or have general claim questions, please contact Rizon US Warranty Department at rizonwarranty@rizontruck.us.

Campaign Reimbursement					
Campaign Number	Models	Allowances		Labor Description	Part Number
C1013110	FEC7K FEC9K	Labor Time	0.9 hour	Install subharness	LT227A01EX
C1013120	FEC7K FEC9K	Labor Time	1.1 hours	Install subharness and connector housing if discoloration is found.	LT227A01EX LT227A03EX
C1013130	FEC7K FEC9K	Labor Time	1.3 hours	Install subharness, terminal connector housing and terminals if deformation is found.	LT227A01EX LT227A03EX LT227A04EX

REPAIR PROCEDURE:

1. Park the vehicle on a flat, level surface, turn off the engine and chock the wheels.

CAUTION!

Do not remove the wheel chocks until all modification work has been completed.

2. Install the subharness and inspect the circuit using instructions found in the Modification Procedure on the next page.

Modification Procedure

Flow chart for field fix action

Note

1. needs to be implemented for all vehicles
2. Depending on connector damage, or may be necessary.

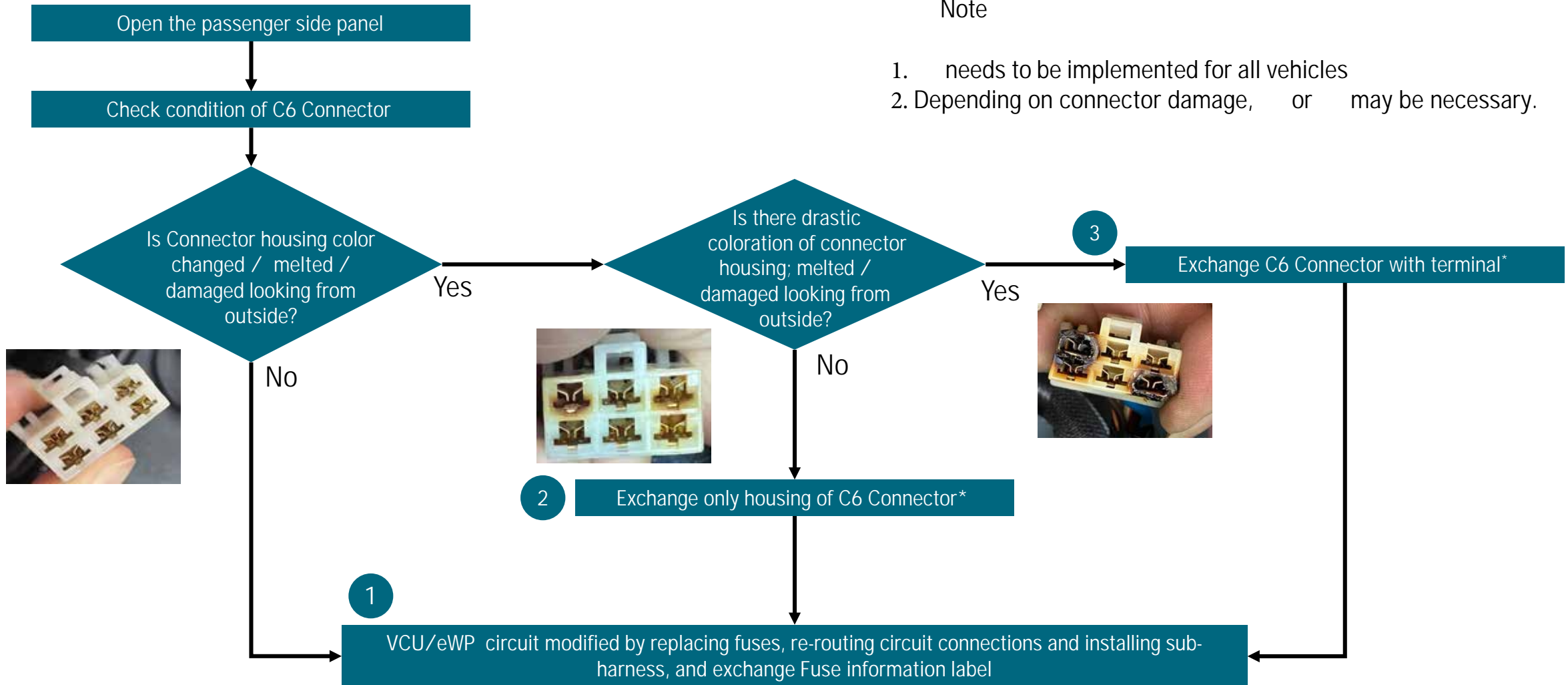

Kit Composition

SYM	Part Name	Part Number	USA			Remarks
			LT227A01EX	LT227A03EX	LT227A04EX	
A	EL.WIR.HARNSS	MX996748	1			
B	EL.WIR.HARNSS	MX996751	1			
F	INFORMATION LABEL	MX995730	1			
E	BAND, CABLE	MK663741	1			
C	TUBE,SUMI	MK410770	2			
D	SPLICES,PARALLEL (P5.5)	MK410136	2			
G	CONNECTOR KIT,M 6P-M	MH050388		1	1	AN6A, Male Depends on Connector condition
H	CONNECTOR KIT,M 6P-F	MH050402		1	1	AN6A, Female Depends on Connector condition
I	SPLICES,PARALLEL (P5.5)	MK410136			9	AN6A, Female Depends on Connector condition
J	SPLICES,PARALLEL (B5.5)	MK410767			3	AN6A, Female Depends on Connector condition
K	TUBE,SUMI	MK410770			12	AN6A, Female Depends on Connector condition

1 Retrofit wiring harness, relocate fuse, replace information label

Step-1 :
Remove the negative battery cable.

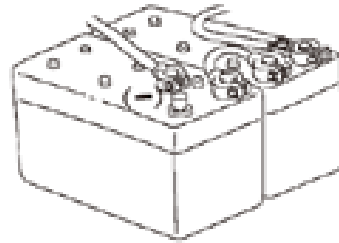

Step-2 :
Remove the passenger side panel.

<LHD>

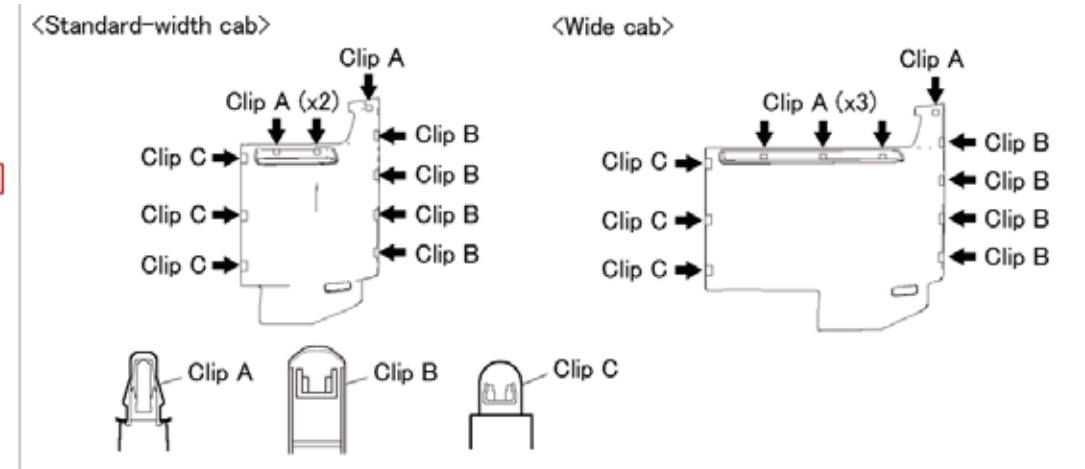
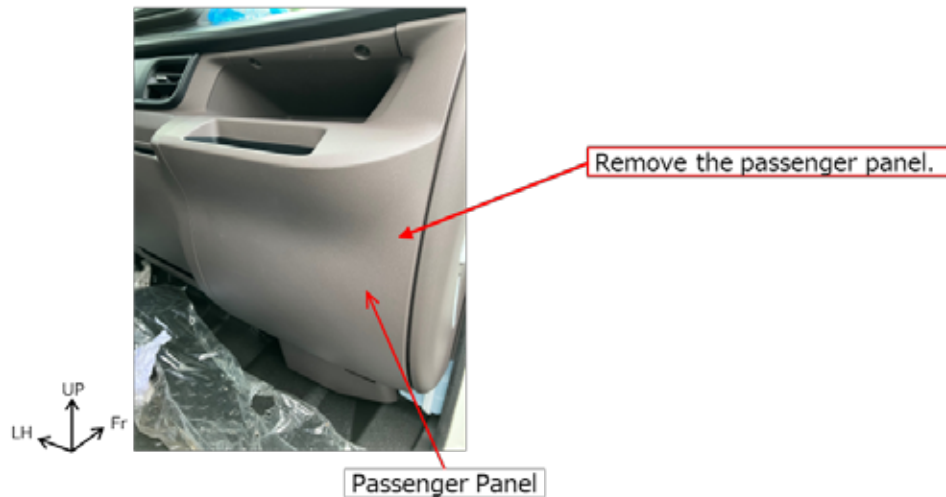

1 Retrofit wiring harness, relocate fuse, replace information label

Step-3 :
Remove the fuse box from the bracket.

Lift the tab (2 places) on the fuse box to unlock it, and then remove the fuse box from the bracket.

<LHD>

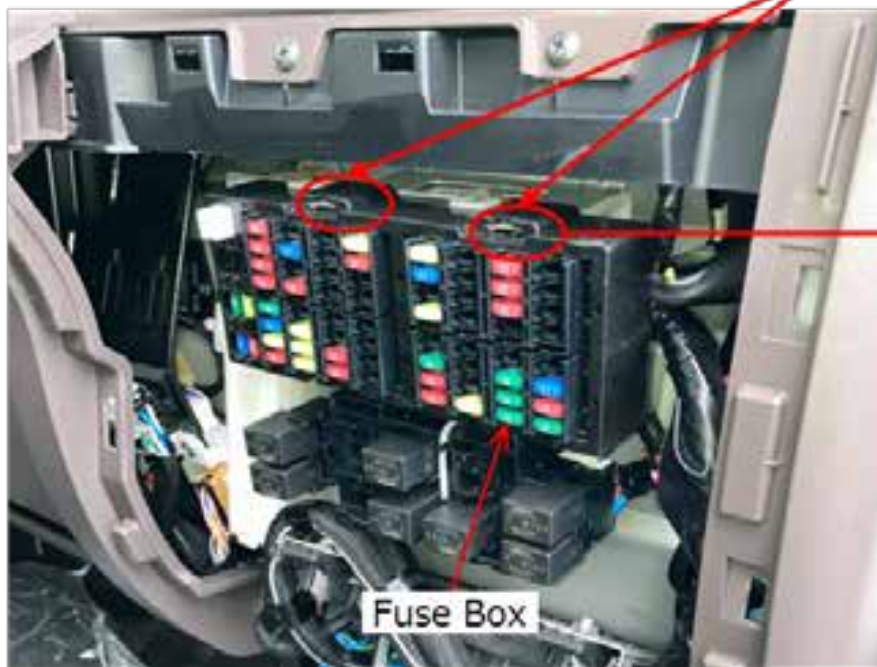

1 Retrofit wiring harness, relocate fuse, replace information label

Step-4 : Remove the cover on the back of the fuse box and cut the band binding the wires.

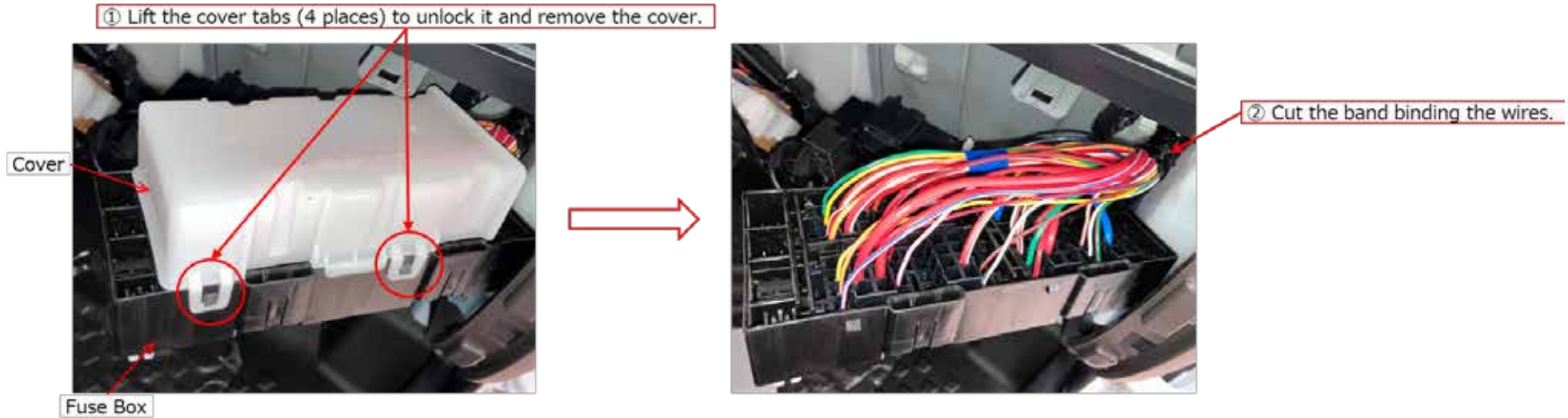

Step-5 : Remove the 20A fuse from B35 in the fuse box.

<LHD>

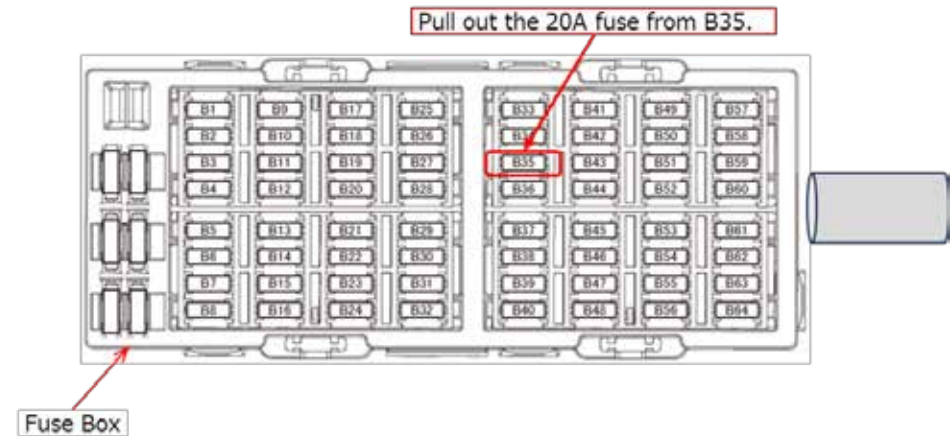

1 Retrofit wiring harness, relocate fuse, replace information label

Step-6 :

Remove the terminal (W/R) from B35 in the fuse box and connect to B15.(Only LHD : use the sub-harness to extend harness to B15)

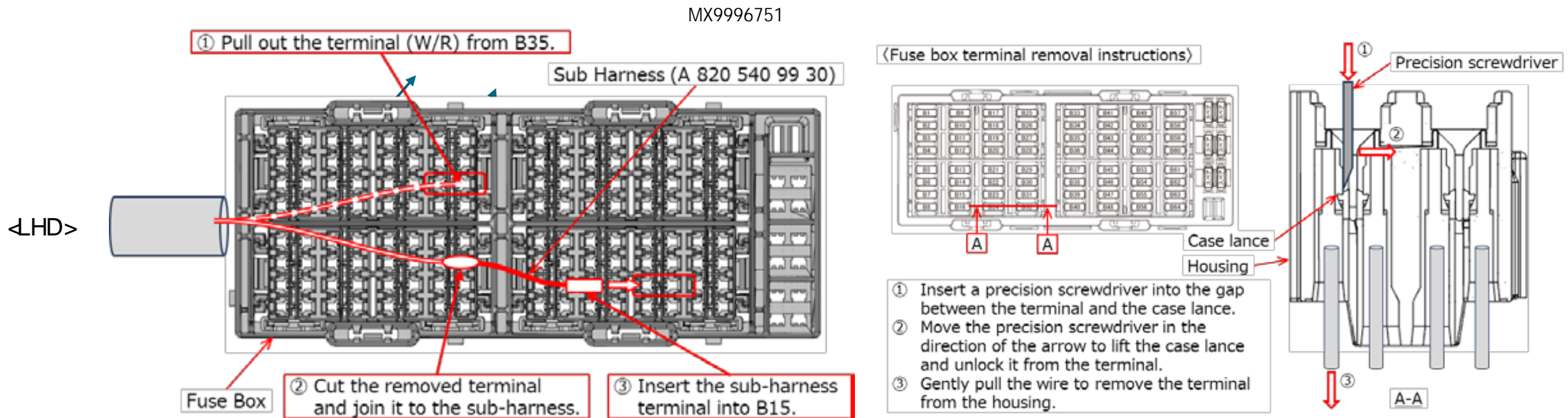

1 Retrofit wiring harness, relocate fuse, replace information label

Step-7 :
Remove the terminal (R/B) from B36 in the fuse box, cut the terminal, and insulate it with vinyl tape.

<LHD>

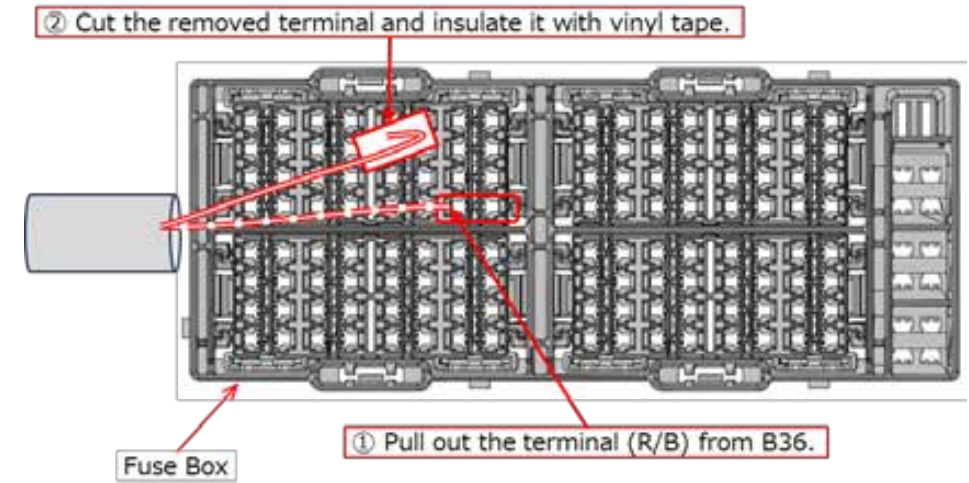

Step-8 :
Remove the terminal (O/B) from B5, cut the terminal, and connect it to the sub-harness.

<LHD>

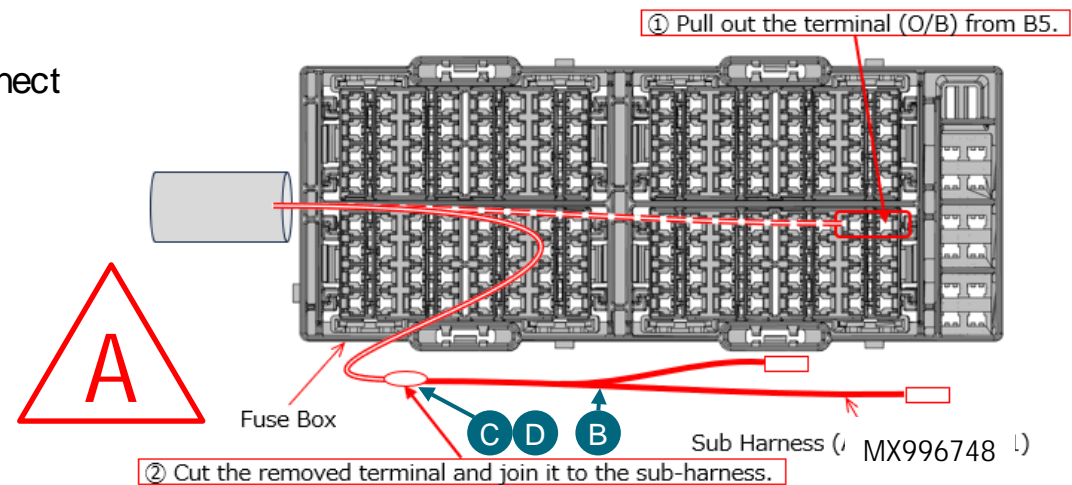

1 Retrofit wiring harness, relocate fuse, replace information label

Step-9 : Insert the sub harness terminals into B36 and B5 of the fuse box. <LHD>

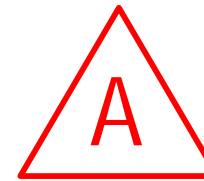
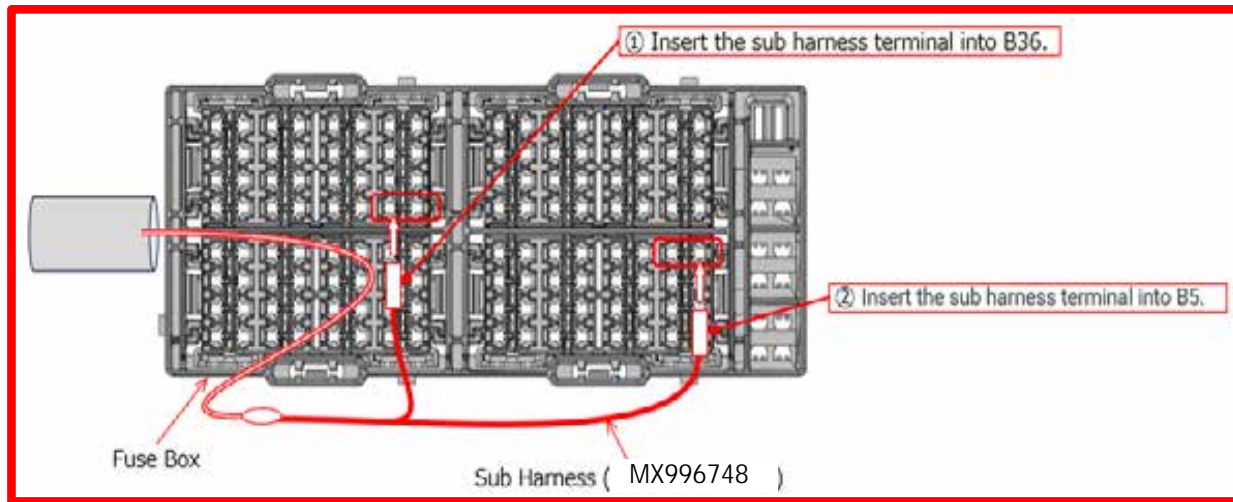

Step-10 : Insert a 20A fuse into B15 in the fuse box.

<LHD>

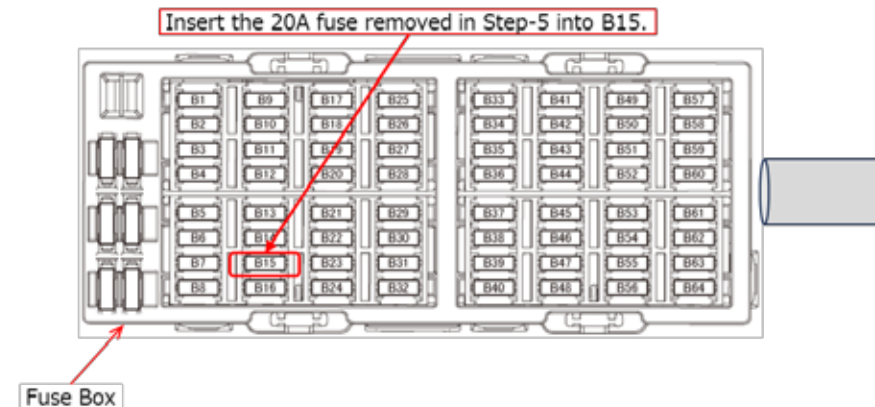

1 Retrofit wiring harness, relocate fuse, replace information label

Step-11 :
Bundle the wires with a band (MK663741) and cut off the excess length of the band

<LHD>

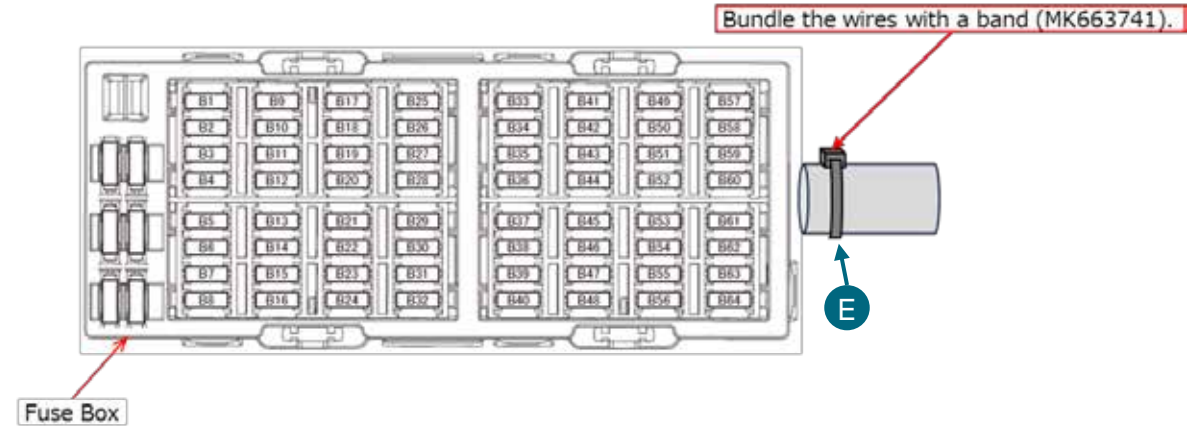

Step-12 :
Restore the vehicle by reversing steps 3 to 4. When installing the cover on the back of the fuse box, be sure to place the insulated wire and added sub harness inside the cover.

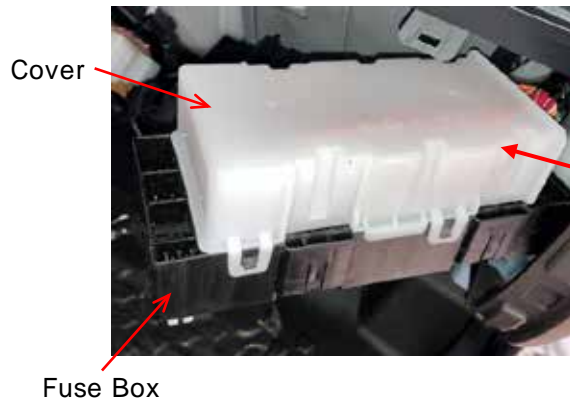

When installing the cover, be sure to place the insulated wire (Step-7) and added sub harnesses (Steps-8 to 9) inside the cover.

1 Retrofit wiring harness, relocate fuse, replace information label

Step-13 :
Remove the fuse information label (MX995730) from the back of the passenger side panel that was removed in step-2 and paste the countermeasure parts.

<LHD>



Peel off the fuse label and paste the countermeasure parts.

Step-14 :
Restore the vehicle by reversing steps 1 to 2

② ③ Replacement of C6 connector

Step-1 :
Remove the passenger side panel.

<LHD>

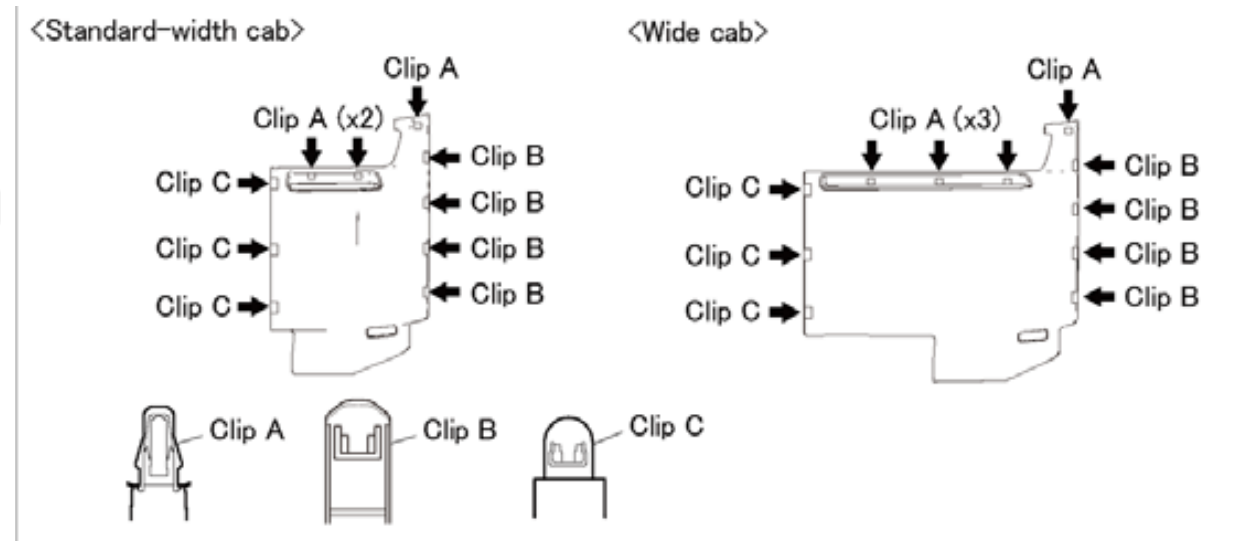
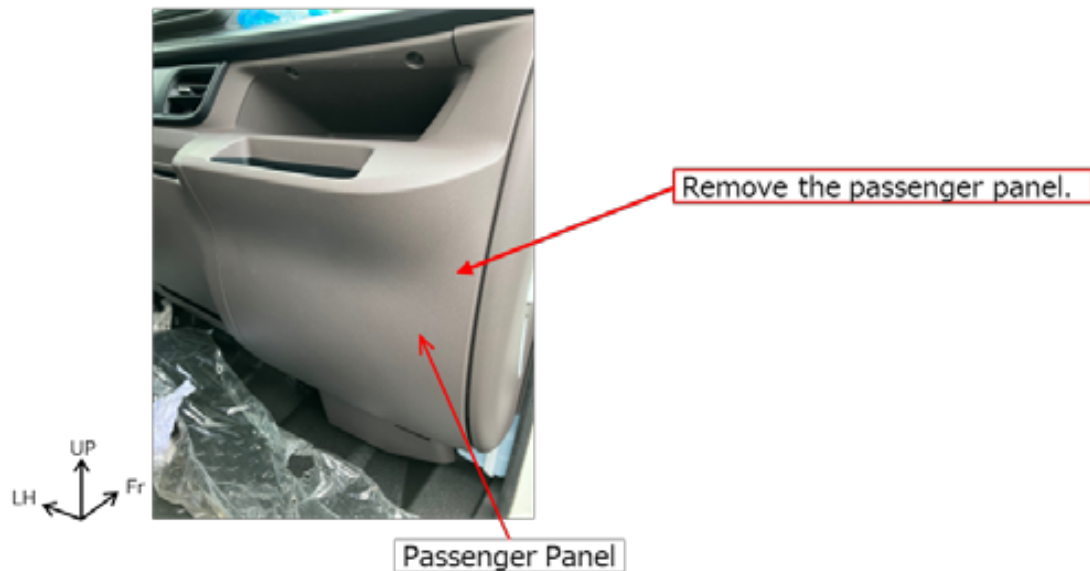

2 3 Replacement of C6 connector

Step-2:

Based on the flow chart for the field fix action, check the condition of the C6 connector.

- If connector housing color change / melting / damage is found, go to Step-3
- If no abnormalities are found, restore the vehicle by reversing step 1 and the procedure is complete.

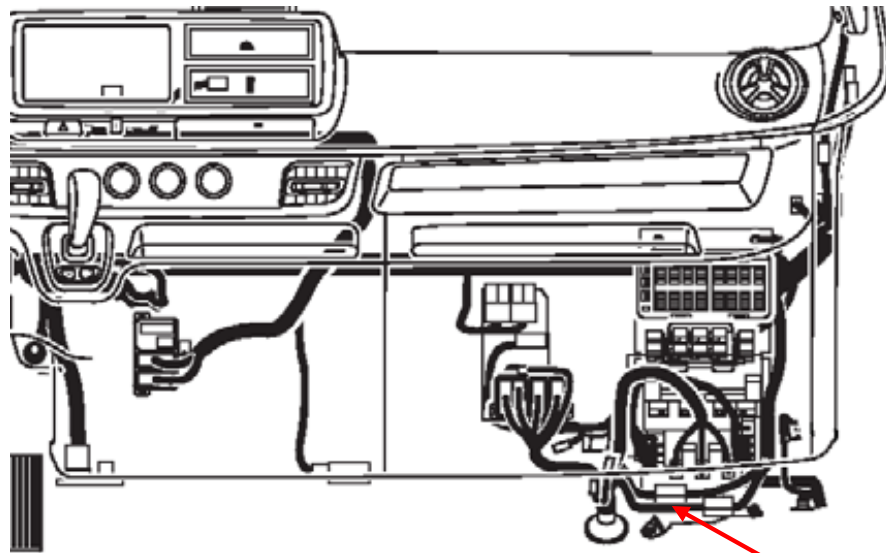

Check C6 connector condition

<LHD>

Step-3 :
Remove the negative battery cable.

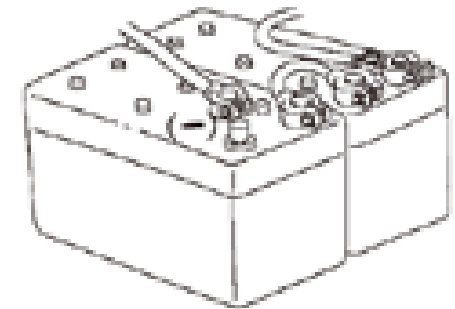

2 3 Replacement of C6 connector

Step-4 :

Refer to group 3-07 of 03DXX0001 in the Harness Repair Manual* and replace the parts according to the condition of the connector.

If only the connector housing is discolored but no deformation or other damage is found in the housing:

2 à Replace only the connector housing (do not use the terminal kit from the repair kit). **G H**

If the connector housing is melted or deformed:

3 à Replace both the terminal kit and the housing.

Please refer to the following for the joint terminals to be used.

(Please note that it is necessary to use P-Type or B-Type depending on the wire diameter.)

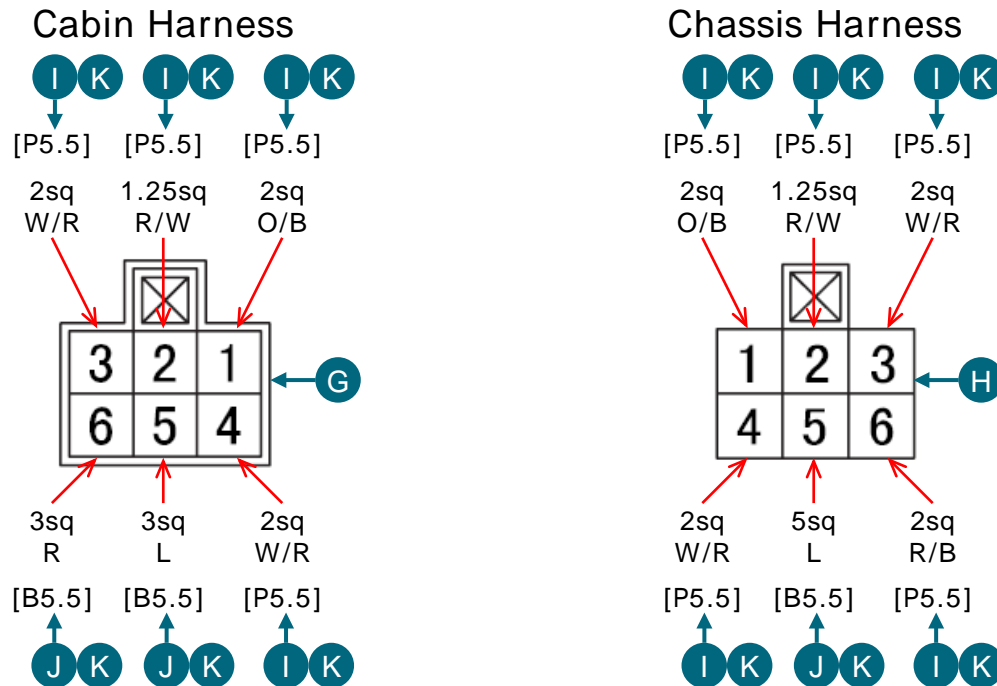

Step-5 :

Restore the vehicle by reversing steps 1 to 3

* Please reach out to your RIZON Product Support Manager for assistance if you require access to this Manual.

Connection with joint terminal

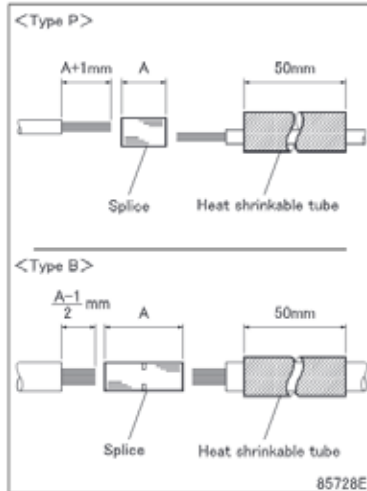

Slide a piece of heat shrinkable tube over the wire on one side, then strip the plastic insulation off the wire ends on both sides. (See *5. Stripping insulation off wires* in P1-20.)

The heat shrinkable tube is available in the following two types:

Heat shrinkable tube
MC037692 (Inner diameter: 7.4mm)
MK410770 (Inner diameter: 7.5mm)

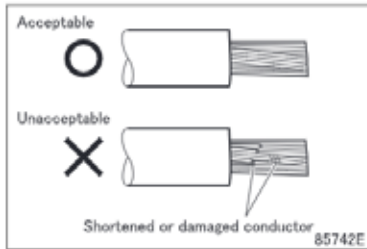

CAUTION

- During stripping process, be careful that no conductors get cut off or damaged.
- If any shortened or damaged conductors are found, cut off the involved portion and strip the wire again.

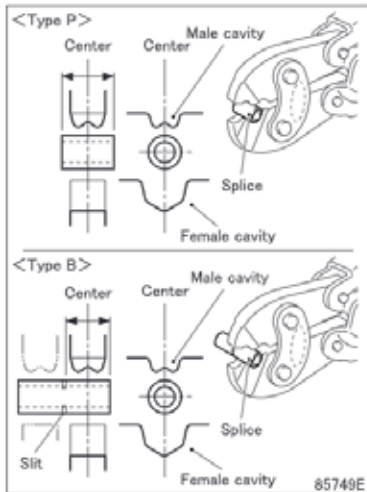

- Open the jaws of the wire clamping tool to a sufficient width.
- Place the splice sleeve on the crimping section of the wire clamping tool as described below, then gradually close the handles until the sleeve is held securely.

<Type P>
Center the splice on the crimping section of the tool.

<Type B>
Align the midpoint of one sleeve segment (section from sleeve end to center slit) with the longitudinal centerline of the tool.

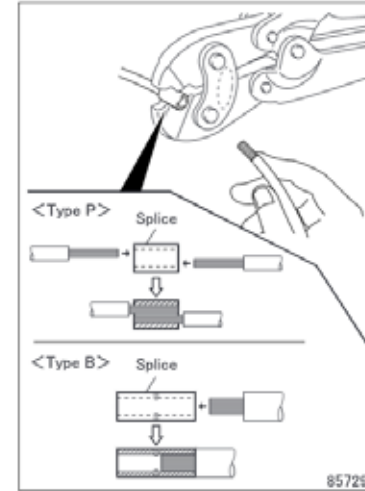

<Type P>

With the splice sleeve held in this position, insert the wires to be joined into the sleeve, one from each end, until the insulation-stripped sections of the wires overlap each other up to their root.

<Type B>

With the splice sleeve held in this position, insert each of the wires to be joined into the sleeve until the insulation comes in contact with the sleeve end face.

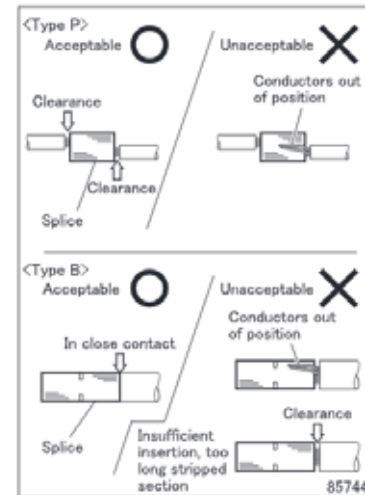

Condition judgment of wires inserted in splice.

Connection with joint terminal

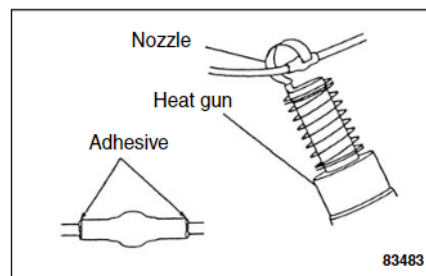
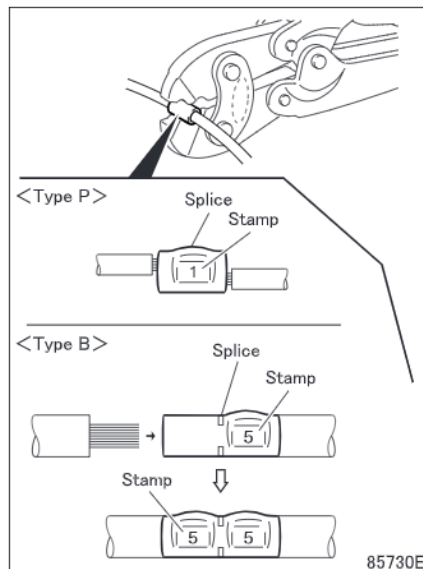

- Fully close the handles of the wire clamping tool. The handles will then come open again and the crimping operation will be complete.
- The area crimped with the wire clamping tool is stamped on the splice.

Area crimped	Stamp
1.25	1
2	2
5.5	5

- Make sure that the wire clamping force satisfies the values in the table below.

Wire size	0.5	0.85	1.25	2	3	5
Wire clamping force (N {kgf} or more)	88 {9}	125 {13}	165 {17}	245 {25}	345 {35}	390 {40}

<Type B>

Insert the other wire into the opposite end of the splice sleeve to crimp it in the same manner.

- Set the heat shrinkable tube at the center of the crimp cavity. Heat it with a heat gun (See Special tools on P2-2.) to shrink the heat shrinkable tube.

CAUTION

- Heat the heat shrinkable tube until adhesive comes out from both ends of the tube.
- Since the nozzle temperature is high during heating, never touch the nozzle.
- Be sure to set the heat gun switch to "COLD" after heating to change hot air to cold air. After cooling the heat gun sufficiently, turn it "OFF".

After crimping, check the following items:

- Check if the wire insulation is inside the heat shrinkable tube.
- Check if adhesive is coming out from the ends of the heat shrinkable tube.
- Check if the heat shrinkable tube is shrunk completely to the wire.
- Check if there is any damage or crack on the heat shrinkable tube.
- Check if the wire is deformed by heating.

M-type connector terminal removal/ fitting instructions

I Removal/fitting of retainer

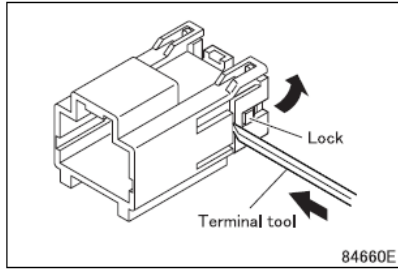

- <Retainer for 4 or more pin>
- Insert the tip of the terminal tool (MH062845) into the gap between the retainer and the housing near at one of the two locks.
 - Pry up the retainer to release the lock.
 - Release the other lock on the opposite side in the same manner. Then, pull out the retainer while turning it.

I Removal of terminal

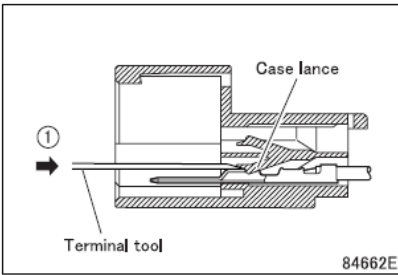

- Removal of male terminal
- ① After removing the retainer, insert the tip of the terminal tool (MH062846) into the gap between the terminal and the case lance.

CAUTION ⚠

Before beginning with the removal procedure, be sure to check that the tip of the terminal tool is in the gap between the terminal and the case lance.

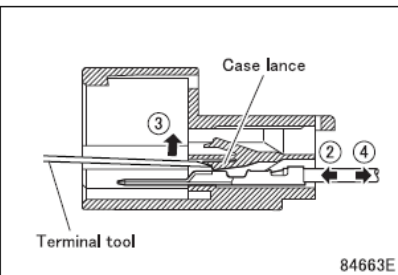

- ② Push in the terminal until it stops moving.
- ③ Move the terminal tool in the direction shown in the figure to push up and release the case lance from the terminal.

CAUTION ⚠

When pushing up the case lance, never allow the terminal tool to come in contact with the terminal. Contact may deform the terminal. The terminal then may be bent when the connector is mated with a female connector, which can cause the terminal to come out of position, resulting in poor continuity.

- ④ Pull the wire gently to remove the terminal from housing.
- CAUTION** ⚠
- If the terminal cannot be removed by pulling the wire gently, take out the terminal tool and repeat the steps again.

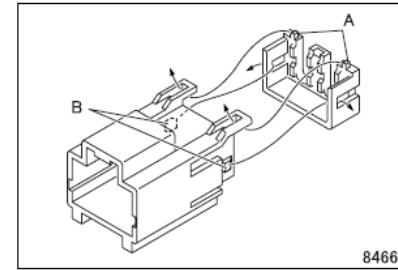

- <Retainer for 4 or more pin>
- Fit the projections A into the corresponding openings in the housing, then fit the projections B on the housing into the slits in the retainer.
 - Check to confirm that the retainer is held evenly on both sides and that it is firmly locked into the left and right arrester section on the housing.

CAUTION ⚠

If the retainer fails to be fitted into position, it is suspected that the terminal is not inserted fully into the housing or it is inserted upside down. Check to ensure that no such deficiencies are included.

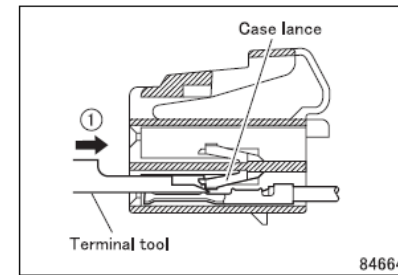

- Removal of female terminal
- ① After removing the retainer, insert the tip of the terminal tool (MH062844) into the gap between the terminal and the case lance.

CAUTION ⚠

Before beginning with the removal procedure, be sure to check that the tip of the terminal tool is in the gap between the terminal and the case lance.

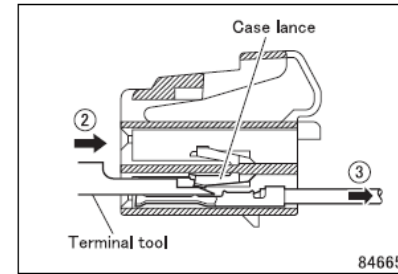

- ② Insert the terminal tool farther, and the case lance will be pushed up and the terminal will be unlocked.
- ③ Pull the wire gently to remove the terminal from housing.

CAUTION ⚠

If the terminal cannot be removed by pulling the wire gently, take out the terminal tool and repeat the steps again.

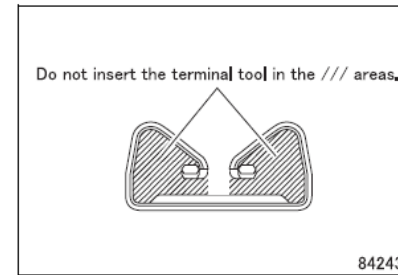

CAUTION ⚠

Never insert the terminal tool in the terminal socket. This can lead to deformed or damaged terminal contact and thereby to poor contact. If the terminal tool is inserted in the socket accidentally, always replace the terminal with a new one even if it appears to be free from any damage.

M-type connector terminal removal/ fitting instructions

I Fitting of terminal

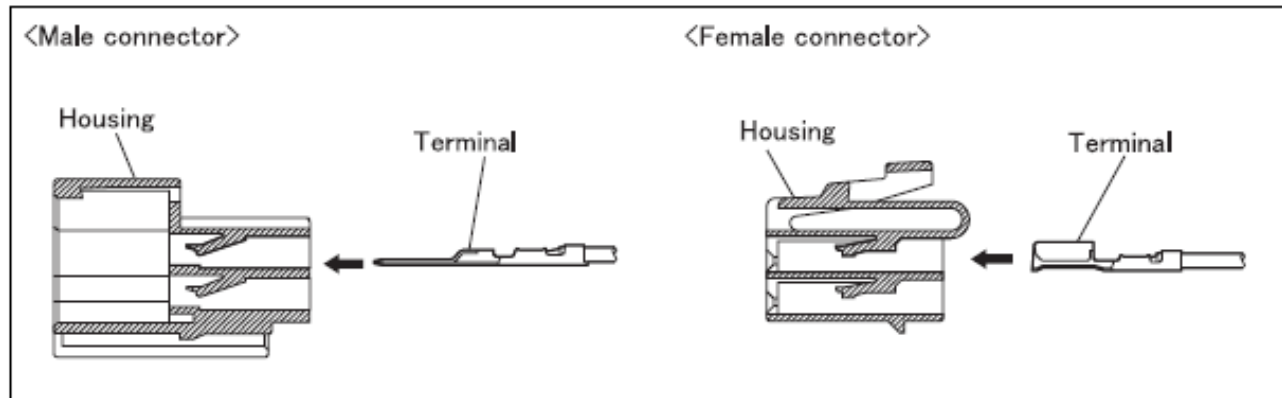

●Fitting of terminal

- Insert the terminal straight into the housing from the backward.
- Push in the terminal until a "clicking" sound for locking is heard.
- After completing the insertion, pull the wire gently to verify that the terminal is securely locked.

CAUTION

If the terminal falls to be fitted into position or if it comes out of position when pulling the wire after fitting, upside down fitted terminal, deformed case lance or deformed terminal is suspected. Determine the cause and replace the faulty parts if any. Then, repeat the steps.