

# ***SERVICE PROCEDURE***

24510  
July, 2024

**SUBJECT: SAFETY RECALL**  
**Tie rod end ball studs on certain 2025 IC Bus® CE school buses built 05/16/2024 through 5/28/2024 built with Dana® Spicer® D-Series or E-Series steer axles.**

## **CUSTOMER LETTER**

Print ready (PDF file) copy of the [Customer Letter](#)

## **DEFECT DESCRIPTION**

Certain tie rod end ball studs supplied to Dana by a third-party supplier, USK International™, and which Dana incorporated into certain steer axles and replacement tie rod assemblies, did not meet case hardening specifications, and there is a risk that the ball studs could be more brittle than intended. If a ball stud is more brittle than expected, it could break, which could affect vehicle steering and could increase the risk of a crash.

## **MODELS INVOLVED**

This safety recall involves certain 2025 IC Bus® CE school buses built 05/16/2024 through 5/28/2024 built with Dana® Spicer® D-Series or E-Series steer axles.

## **ELIGIBILITY**

This procedure applies ONLY to vehicles marked in the International® Service Portal<sup>SM</sup> with Safety Recall 24510. Also complete any other open campaigns listed on the Service Portal at this time.

## PARTS INFORMATION

**NOTE: Parts are only required if tie rod was built with a suspect Julian date. See Table 3 in the Service Procedure for suspect Julian dates.**

Tie Rod Part Number (Cross Tube)	Navistar Part Number	Part Description	Quantity
817755 or 971092	103389	Cotter PIN	2 - If Required
	9412231	Nut	2 - If Required
	DS818472	Left Tie Rod End	1 - If Required
	DS818471	Right Tie Rod End	1 - If Required
10036700 or 10036701	103389	Cotter PIN	2 - If Required
	9412231	Nut	2 - If Required
	DS685365	Left Tie Rod End	1 - If Required
	DS685366	Right Tie Rod End	1 - If Required

**Table 1** Parts Information

**NOTE: If tie rod ends are not available through Navistar® at the time of repair, use Table 2 to obtain parts from a reputable outside vendor using the Dana part number as a cross reference.**

Navistar Part Number	Dana Part Number	Part Description
DS685365	685365	Left Tie Rod End
DS685366	685366	Right Tie Rod End
DS818472	818472	Left Tie Rod End
DS818471	818471	Right Tie Rod End

**Table 2** Dana Cross Reference Parts Information

## SERVICE PROCEDURE

**WARNING!** To prevent personal injury and / or death, or damage to property, park vehicle on hard flat surface, turn the engine off, set the parking brake and install wheel chocks to prevent the vehicle from moving in either direction.

**WARNING!** To prevent personal injury and / or death, or damage to property, if the vehicle must be raised, do not work under the vehicle supported only by jacks. Jacks can slip or fall over.

**WARNING!** To prevent personal injury and / or death, always wear safe eye protection when performing vehicle maintenance.

**WARNING!** To prevent personal injury and / or death, or damage to property, allow engine / vehicle components to cool before servicing.

**WARNING!** To prevent personal injury and / or death, or damage to property, keep flames or sparks away from vehicle and do not smoke while servicing the vehicle's batteries. Batteries expel explosive gases.

1. Park vehicle on flat surface.
2. Shift transmission to Park or Neutral and set parking brake.
3. Install wheel chocks.



**Figure 1. Julian Date Location**

1. Part number
2. Julian date code

**NOTE:** Each tie rod cross tube has a Julian date code stamped as shown in Figure 1. If the date is not visible, remove paint from the area and cover the number with chalk for visibility.

4. On the front tie rod assembly, locate the part number (Figure 1, Item 1) and Julian date code (Figure 1, Item 2) stamped into tie rod cross tube.
5. Record the part number and Julian date code.

6. Refer to Table 3 for suspect part number / Julian date codes:
- a. If component part number includes a suspect Julian date code, replace both tie rod ends. Proceed to Step 7.
  - b. If component part number does not include a suspect Julian date code, no further action is necessary. Proceed to Step 28.

Tie Rod Part Number	Suspect Julian Date Code						
817775	100_24	116_24	117_24				
971092	100_24	106_24	110_24	113_24	115_24	118_24	103_24
10036700	100_24	103_24	106_24	107_24			
10036701	101_24	106_24	109_24				

**Table 3** Suspect Julian Date Codes

**NOTE: Steps 7 through 27 are ONLY required if the tie rod cross tube has a suspect Julian date.**

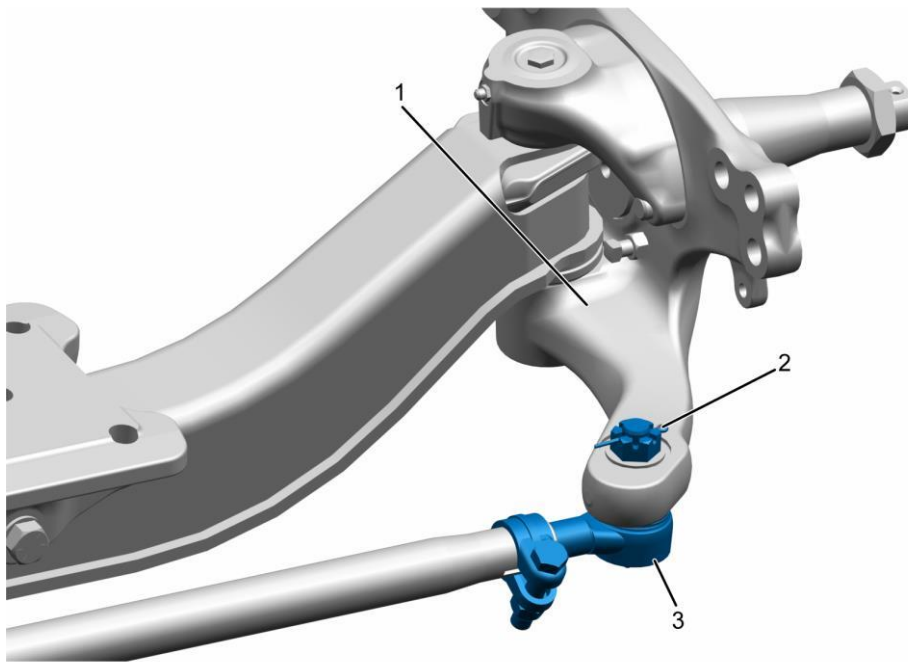

0000485308

**Figure 2. Tie Rod at Knuckle**

1. Knuckle
2. Cotter pin and castle nut
3. Tie rod end

7. Turn front wheels to access tie rod end (Figure 2, Item 3).
8. Remove and discard the cotter pin and castle nut (Figure 2, Item 2).
9. Using appropriate tool, separate the tie rod end (Figure 2, Item 3) from knuckle (Figure 2, Item 1).

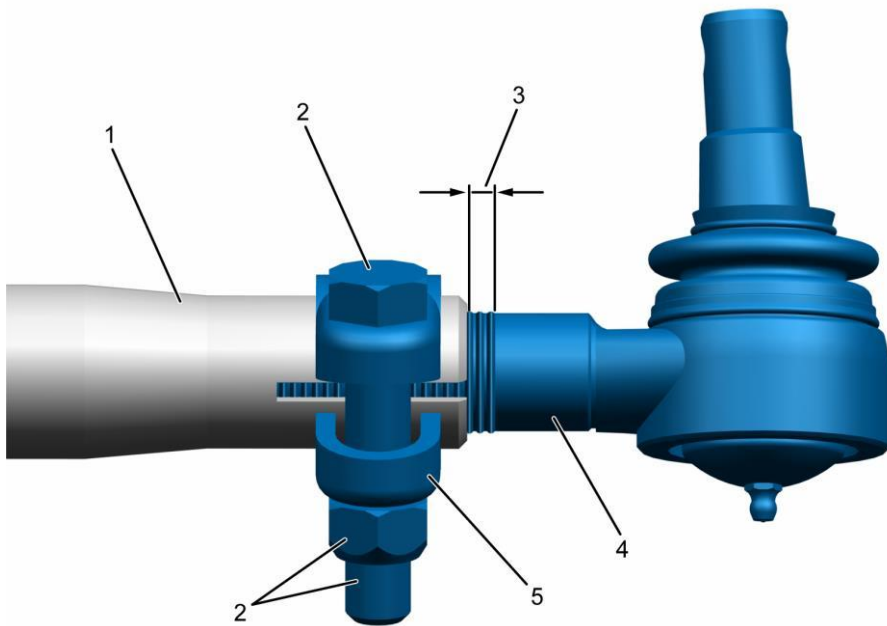

0000485309

### Figure 3. Tie Rod End

1. Cross tube
2. Bolt and nut assembly
3. Exposed threads
4. Tie rod end
5. Clamp

10. Count and record the number / length of exposed threads (Figure 3, Item 3) between the cross tube (Figure 3, Item 1) and tie rod end (Figure 3, Item 4) for reinstallation.
11. Loosen nut and bolt assembly (Figure 3, Item 2) on the clamp (Figure 3, Item 5). Discard nut.
12. Unscrew and remove tie rod end (Figure 3, Item 4) from cross tube (Figure 3, Item 1).
13. Destroy threads on suspect tie rod end and discard.
14. Position clamp (Figure 3, Item 5) over cross tube (Figure 3, Item 1). Loosely install bolt and new nut (Figure 3, Item 2) on clamp.
15. Install new tie rod end (Figure 3, Item 4) into cross tube (Figure 3, Item 1).

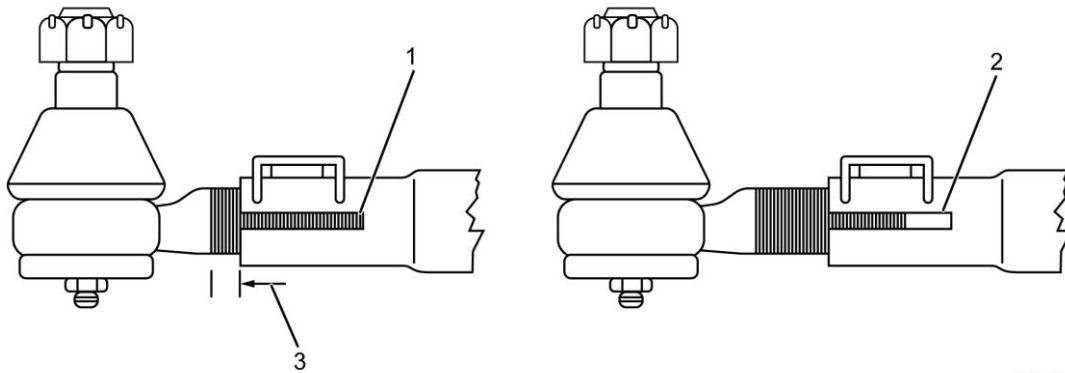

0000485211

**Figure 4. Tie Rod End into Cross Tube**

1. Correct installation - tie rod end fully inserted
2. Incorrect installation - tie rod end NOT fully inserted
3. Exposed threads

**NOTE: Cross tubes are manufactured with left-hand and right-hand threads to correspond with each side of the vehicle.**

**NOTE: Threaded portion of tie rod must be fully inserted into cross tube.**

16. Using cross tube split to inspect, ensure tie rod threads are fully inserted (Figure 4, Item 1). If any spacing between edge of cross tube and tie rod threads is visible (Figure 4, Item 2), the tie rod is NOT fully installed.
17. Using the prerecorded exposed threads (Figure 4, Item 3), ensure new tie rod end has the same number / length of exposed threads.
18. Ensure clamp (Figure 3, Item 5) is positioned over split located on cross tube.
19. Hand-tighten bolt and nut assembly (Figure 3, Item 2) on the clamp.
20. Position tie rod end (Figure 2, Item 3) into steering knuckle (Figure 2, Item 1).
21. Loosely install new castle nut (Figure 2, Item 2).

**NOTE: Only tighten and do not loosen the nut to achieve alignment for the cotter pin.**

22. Using torque wrench, tighten castle nut to 120–160 lb-ft (163–217 N·m), ensuring cotter pin hole is properly aligned.
23. Install new cotter pin (Figure 2, Item 2) fully into castle nut / tie rod end. Bend back each prong of the cotter pin to secure.

24. Using a torque wrench, tighten clamp bolt and nut assembly (Figure 3, Item 2) to 45–60 lb-ft (61–81 N·m).
25. Repeat Steps 7–24 for opposite side.

**NOTE:** Toe is the inward or outward angle of the front of the tires. A rolling toe check can be performed by measuring the distance between two points at the rear of the front tires, driving forward, and then measuring the distance between the same two points at the front of the tires. When the front measurement is less than the rear measurement, it is referred to as toe-in.

**NOTE:** To determine factory toe setting, refer to the details section of the Service Portal for the VIN you are working on. This number is in millimeters to meters and will need to be converted to fractional inches. The optimal desired setting should result in a toe-in final measurement. If you are unable to locate your specific target value within the Service Portal, consider setting your toe-in to 1/16 inch +/- 1/16 inch.

**NOTE:** If you are unsure about how to perform a rolling toe check, please refer to the LMS system in the Service Portal and enroll in *Measuring Front Axle Toe (7942)*, or refer to the most current Technician Manual for detailed instruction.

26. Perform toe-in adjustment procedure. Refer to appropriate technician manual for detailed instruction.
27. If tie rod clamp fasteners were loosened to adjust the toe-in measurement, then using a torque wrench, tighten clamp bolt and nut assembly (Figure 3, Item 2) to 45–60 lb-ft (61–81 N·m).
28. Remove wheel chocks.

## **END OF SERVICE PROCEDURE**



## **LABOR INFORMATION**

<b>Operation Number</b>	<b>Description</b>	<b>Time</b>
A40-24510-1	Tie Rod End Inspection	0.2 hr
A40-24510-2	Tie Rod End Inspection and Replacement	0.7 hr
A40-24510-3	Toe Adjustment	0.2 hr

**Table 4** Labor Information

## **CAMPAIGN IDENTIFICATION LABEL**

Each vehicle corrected in accordance with this campaign must be marked with a CTS-1075 Campaign Identification Label.

Complete the label and attach on a clean surface next to the vehicle identification number (VIN) plate.



## **ADMINISTRATIVE / DEALER RESPONSIBILITIES**

### **WARRANTY CLAIMS**

Warranty claim expense is to be charged to Warranty. Claims are to be submitted in the normal manner, making reference to Safety Recall 24510.

Section 7 of the Warranty Policy and Procedures Manual contains further information related to the submission and processing of AFC / Recall claims.

As with all claim submissions, items acquired locally must be submitted in the "Other Charges" tab. The cost of any bulk items (such as a bag of cable tie straps, roll of wire, barrel of oil, or tube of silicone) should be prorated for the cost of the individual pieces / amount used during each repair.

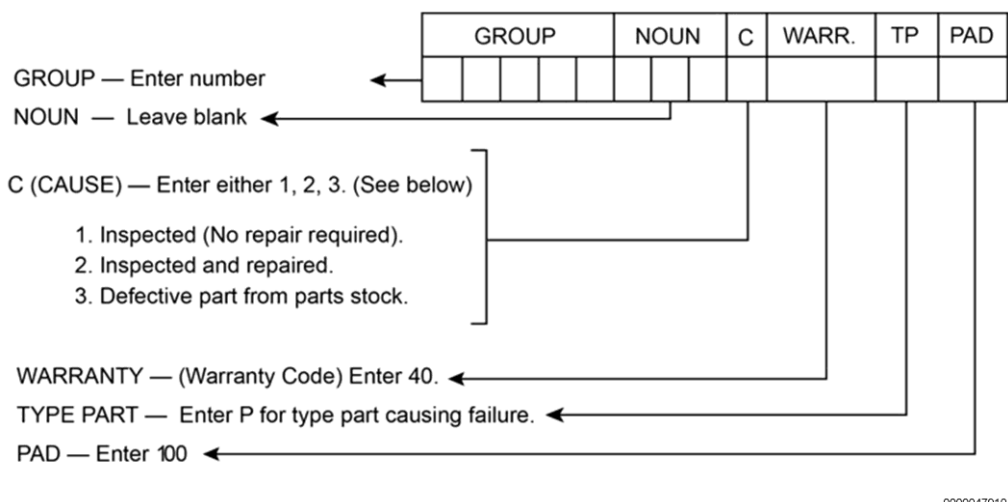

### UNITED STATES AND POSSESSIONS

The National Traffic and Motor Vehicle Safety Act, as amended, provides that each vehicle that is subject to a vehicle recall campaign must be adequately repaired within a reasonable time after the owner has tendered it for repair. A failure to adequately repair within 60 days after a tender of a vehicle is prima facie evidence of failure to repair within a reasonable time. If the condition is not adequately repaired within 60 days, the owner may be entitled to replacement with an identical or reasonable equivalent vehicle at no charge, or to a refund of the purchase price less a reasonable allowance for depreciation.

Dealers must correct all vehicles subject to this campaign at no charge to the owner, regardless of mileage, age of vehicle, or ownership, from this time forward.

Dealers should proceed immediately to make necessary correction to units in inventory. Federal law prohibits a dealer from delivering under a sale or lease, a new motor vehicle or any new or used item of motor vehicle equipment (including a tire) covered by the notification of a recall until the defect or noncompliance is remedied.

Dealers must make every effort to promptly schedule an appointment with each owner to repair his or her vehicle as soon as possible. However, consistent with the customer notification, dealers are expected to complete the repairs on the mutually agreed upon service date.

Dealers involved in the recall process will be furnished a listing of owner names and addresses to enable them to follow up with owners and have the vehicles corrected. Use of this listing must be limited to this campaign because the list may contain information obtained from state motor vehicle registration records, and the use of such motor vehicle registration data for purposes other than this campaign is a violation of law in several states.

---

**VEHICLE RECALL 24510**

## **CANADA**

Dealers must correct all vehicles subject to this campaign at no charge to the owner, regardless of mileage, age of vehicle, or ownership, from this time forward.

Dealers should proceed immediately to make necessary correction to units in inventory. All inventory vehicles subject to this recall campaign must be corrected prior to sale, transfer or delivery. If vehicles have been sold or transferred and you are in receipt of Customer Notification Letters and Authorization for Recall Service cards for those vehicles, the transfer location or customer must be notified immediately from your dealer location.

Dealers must make every effort to promptly schedule an appointment with each owner to repair his or her vehicle as soon as possible. However, consistent with the customer notification, dealers are expected to complete the repairs on the mutually agreed upon service date.

Dealers involved in the recall process will be furnished a listing of owner names and addresses to enable them to follow up with owners and have the vehicles corrected. Use of this listing must be limited to this campaign because the list may contain information obtained from state motor vehicle registration records, and the use of such motor vehicle registration data for purposes other than this campaign is a violation of law in several states.

## **EXPORT**

Export Distributors should proceed immediately to make necessary correction to units in inventory. All inventory vehicles subject to this recall campaign must be corrected prior to sale, transfer or delivery. If vehicles have been sold or transferred and you are in receipt of Customer Notification Letters and Authorization for Recall Service cards for those vehicles, the transfer location or customer must be notified immediately from your distributor location.

Export Distributors are to submit warranty claims in the usual manner making reference to this recall number.

Export Distributors are expected to provide full cooperation and follow-up with respect to this important subject matter. If you have any questions or need further assistance, please contact the Regional Service Manager at your regional office.

## **NAVISTAR, INC.**