



Stacy L. Balzer  
 Director  
 Service Engineering Operations  
 Ford Customer Service Division

Ford Motor Company  
 PO Box 1904  
 Dearborn, Michigan 48121

May 12, 2025

**TO:** All U.S. Ford and Lincoln Dealers

**SUBJECT:** **New Vehicle Demo/Delivery Hold - Safety Recall 24S06 – Supplement #1**

Certain 2018-2020 Model Year Ford Expedition and  
 Lincoln Navigator Vehicles  
 Inadvertent Retractor Pretensioner Deployment

**REF:** **New Vehicle Demo/Delivery Hold - Safety Recall 24S06**

Certain 2018-2020 Model Year Ford Expedition and  
 Lincoln Navigator Vehicles  
 Inadvertent Retractor Pretensioner Deployment  
 published June 20, 2024

**New! REASON FOR THIS SUPPLEMENT**

- *A new date code range of suspect pretensioners has been developed for vehicles that have yet to be serviced under 24S06. Dealers are to use the new list when inspecting and servicing these vehicles, provided in the new technical instructions.*
- *Some vehicles that have been serviced under 24S06 may get an updated recall letter under 25S31 for a re-inspection, but no new customer notifications for this recall will be sent. This supplement is only for those original vehicles of 24S06.*

**AFFECTED VEHICLES**

Vehicle	Model Year	Assembly Plant	Build Dates
Ford Expedition	2018	Kentucky	1-Oct-2018 through 16-Oct-2018
Ford Expedition	2019	Kentucky	1-Oct-2018 through 30-Jun-2019
Ford Expedition	2020	Kentucky	12-Apr-2019 through 27-Apr-2019
Lincoln Navigator	2018	Kentucky	1-Oct-2018 through 15-Oct-2018
Lincoln Navigator	2019	Kentucky	1-Oct-2018 through 28-Jun-2019
Lincoln Navigator	2020	Kentucky	9-Apr-2019 through 27-Apr-2019

US population of affected vehicles: 77,587. Affected vehicles are identified in OASIS and FSA VIN Lists.

**REASON FOR THIS SAFETY RECALL**

On some of the affected vehicles, the driver and/or front passenger seatbelt retractor pretensioners may deploy inadvertently while the vehicle's engine is on. Inadvertent deployment of the retractor pretensioner will result in the seatbelt being locked in position and will not retract or extend, which is noticeable to the occupant. While the primary seatbelt locking functions continue to function properly, a seatbelt that does not retract or extend may result in injury in the event of a crash.

## **SERVICE ACTION**

DO NOT DEMONSTRATE OR DELIVER any new in-stock vehicles involved in this safety recall. Before demonstrating or delivering any new in-stock vehicles involved in this recall, dealers are to first inspect each vehicle to determine if the vehicle seat belt retractor part numbers are on the replacement list, then replace those retractors that are involved. Dealers should also follow instructions relating to TSB 20-170. This service must be performed on all affected vehicles at no charge to the vehicle owner. For new vehicle storage guidelines, refer to EFC13033, Storage Guidelines for New Vehicles.

To assist vehicle owners to have this repair completed when parts are available, dealers should:

- Arrange to pick up the owner's vehicle and drive it to the dealership for repairs and re-deliver the owner's vehicle after repairs have been completed.
- Pick-Up & Delivery should be made available for all customers.

## **OWNER NOTIFICATION MAILING SCHEDULE**

Owner letters were mailed the week of July 8, 2024. Dealers should repair any affected vehicles that arrive at their dealerships, whether or not the customer has received a letter.

## **PLEASE NOTE:**

**Federal law requires dealers to complete this recall service before a new vehicle is delivered to the buyer or lessee. Violation of this requirement by a dealer could result in a civil penalty of up to \$27,168 per vehicle. Correct all vehicles in your new vehicle inventory before delivery.**

## **NEW! ATTACHMENTS**

- Administrative Information
- Labor Allowances and Parts Ordering Information
- *Technical Instructions*

## **QUESTIONS & ASSISTANCE**

For questions and assistance, contact the Special Service Support Center (SSSC) via the SSSC Web Contact Site. The SSSC Web Contact Site can be accessed through the Professional Technician System (PTS) website using the SSSC link listed at the bottom of the OASIS VIN report screen or listed under the SSSC tab.

Customer Service Division

**Safety Recall 24S06 – Supplement #1**

**MOBILE SERVICE REPAIR ASSESSMENT LEVEL**

All repairs in this program have the following assessment level.

Ⓢ - Not a Mobile Service Repair

**OASIS ACTIVATION**

OASIS will be activated on June 20, 2024.

**FSA VIN LISTS ACTIVATION**

FSA VIN Lists were available through <https://web.fsavinlists.dealerconnection.com> by June 20, 2024. Owner names and addresses were available by July 26, 2024.

**NOTE:** Your FSA VIN Lists may contain owner names and addresses obtained from motor vehicle registration records. The use of such motor vehicle registration data for any purpose other than in connection with this recall is a violation of law in several states, provinces, and countries. Accordingly, you must limit the use of this listing to the follow-up necessary to complete this recall.

**SOLD VEHICLES**

- Ford has not issued instructions to stop selling/delivering or driving used vehicles under this safety recall. Owners should contact their dealers for an appointment to have their vehicles remedied as soon as practicable.
- Immediately contact any of your affected customers whose vehicles are not on your VIN list but are identified in OASIS. Give the customer a copy of the Owner Notification Letter (when available) and schedule a service date.
- Correct other affected vehicles identified in OASIS which are brought to your dealership.
- Dealers are to prioritize repairs of customer vehicles over repairs of new and used vehicle inventory.

**STOCK VEHICLES**

- Correct all affected units in your new vehicle inventory before delivery.
- Use OASIS to identify any affected vehicles in your used vehicle inventory.

**DEALER-OPERATED RENTAL VEHICLES**

The Fixing America's Surface Transportation (FAST) Act law effective June 2016 prohibits a rental company from selling, renting, or leasing vehicles subject to a safety or compliance recall. Please consult your legal counsel for legal advice.

**BRANDED / SALVAGED TITLE VEHICLES**

Affected branded / salvaged title vehicles are eligible for this recall.

**Safety Recall 24S06 – Supplement #1****OWNER REFUNDS**

- **This safety recall must still be performed, even if the owner has paid for a previous repair. Claiming a refund will not close the recall on the vehicle.**
- Ford Motor Company is offering a refund for owner-paid repairs covered by this recall if the repair was performed before the date indicated in the reimbursement plan, which is posted with this bulletin. Owners are directed to seek reimbursement through authorized dealers or, at their option, directly through Ford Motor Company at PO Box 6251, Dearborn, MI 48121-6251.
- Dealers are also pre-approved to refund owner-paid emergency repairs that were performed away from an authorized servicing dealer after the end date specified in the reimbursement plan. Non-covered repairs, or those judged by Ford to be excessive, will not be reimbursed.
- Refunds will only be provided for the cost associated with the front pretensioner inspection and/or replacement.

**PICK-UP & DELIVERY- Non-participating Dealers**

Ford Dealers not participating in the 2024 Remote Experience Program for Pick-Up & Delivery are authorized to claim unique services for completing this program.

- Dealers are authorized to claim one-half labor hour per repair for vehicle Pick-Up & Delivery services. Refer to Labor Allowances for details.
- Dealers must retain a Vehicle Pick-Up & Delivery Record with the repair order documentation.

**LINCOLN PICK-UP & DELIVERY**

Owners of Lincoln vehicles within a 4 year / 50,000-mile warranty have the option of requesting Pick-Up & Delivery service with a Lincoln loaner (up to 2 days), from their dealership. For details, reference EFC14054, 2024 Lincoln Pick-Up & Delivery Updates.

**ADDITIONAL REPAIR (LABOR TIME AND/OR PARTS)**

Additional repairs identified as necessary to complete the FSA should be managed as follows:

- For related damage and access time requirements, refer to the Warranty and Policy Manual / Section 6 – Ford & Lincoln Program Policies / General Information & Special Circumstances for FSAs / Related Damage.
- For vehicles within new vehicle bumper-to-bumper warranty coverage, no SSSC approval is required, although related damage must be on a separate repair line with the “Related Damage” radio button checked.
  - Ford vehicles – 3 years or 36,000 miles
  - Lincoln vehicles – 4 years or 50,000 miles
- For vehicles outside new vehicle bumper-to-bumper warranty coverage, submit an Approval Request to the SSSC Web Contact Site before completing the repair.



## Labor Allowances and Parts Ordering Information

Page 1 of 2

### Safety Recall 24S06 – *Supplement #1*

#### **LABOR ALLOWANCES**

Description	Labor Operation	Labor Time
INSPECT for evaporator drain elbow presence and the date code on both seat belt retractors.	24S06A	0.6 Hours
Extra time to install evaporator drain elbow (Can be claimed with A and C or D)	24S06B	0.6 Hours
Extra time to replace <b>ONE</b> belt retractor (Can be claimed with A and B)	24S06C	0.4 Hours
Extra time to replace <b>BOTH</b> seat belt retractors (Can be claimed with A and B)	24S06D	0.7 Hours
<b>Lincoln</b> vehicle PDL Allowance: <b>Only</b> vehicles <b>outside</b> of Lincoln PDL contract coverage of <b>4 years/50,000 miles</b> . <b>NOTE:</b> This allowance is for dealer-performed vehicle PDL for dealership repairs only. Can only be claimed once, regardless of outstanding FSAs repaired.	24S06LL	0.5 Hours
Vehicle Pick-Up & Delivery Allowance: <b>This allowance is only for <u>non-eligible</u> 2024 Remote Experience Program Dealers.</b> <b>NOTE:</b> This allowance is for dealer-performed vehicle Pick-Up & Delivery for dealership repairs only. Can only be claimed once, regardless of outstanding FSAs repaired.	24S06PP	0.5 Hours

#### **PARTS REQUIREMENTS / ORDERING INFORMATION**

Service Part Number	Claim Quantity	Package Order Quantity	Number in Package	Description
Base part # - 78611B09**	1 as required	1	1	LH Seat Belt Retractor **Interior Color Dependent
Base part # 78611B08**	1 as required	1	1	RH Seat Belt Retractor **Interior Color Dependent
4M2Z-6A614-AA	1	1	1	Hose-connecting
Nashua® 324A or 3M™ 3340 Foil Tape	Claim as Misc. Expense: OTHER 1 Roll will service many vehicles			Obtain locally if the Evaporator Drain Elbow must be installed

Order your parts through normal order processing channels. To guarantee the shortest delivery time, an emergency order for parts must be placed.

#### **DEALER PRICE**

For the latest prices, refer to DOES II.

**Safety Recall 24S06 – Supplement #1**

**PARTS RETENTION, RETURN, & SCRAPPING**

Follow the provisions of the Warranty and Policy Manual, Section 1 - WARRANTY PARTS RETENTION AND RETURN POLICIES. If a replaced part receives a scrap disposition, the part must be scrapped by all applicable local, state, and federal environmental protection and hazardous material regulations. Federal law prohibits selling motor vehicle parts or components that are under safety, compliance, or emissions recall.

**EXCESS STOCK RETURN**

The excess stock returned for credit must have been purchased from Ford Customer Service Division by Policy Procedure Bulletin 4000.

**REPLACED FSA PARTS INSPECTION AND SIGN OFF**

Effective March 1<sup>st</sup>, 2021, all parts replaced as part of an FSA repair with a repair order open date of March 1<sup>st</sup>, 2021, or later must be inspected and signed off on the repair order by a member of your dealer fixed operations management team or an employee of the task has been delegated to. If the task is to be delegated to a non-management employee, the employee needs to be someone other than the technician who completed the repair and needs to understand the importance of completing this task consistently and accurately.

- All parts replaced as part of an FSA repair should be returned to the parts department following the Warranty Parts Retention and Return Policies.
- Inspect the replaced parts to verify the FSA repair was completed.
- If the FSA repair is found to be complete, the designated employee signs the repair order line or parts return stamp area (electronic or hand signed) for the FSA repair indicating the parts were inspected and validated to have been replaced.
- After the parts have been inspected, they should be handled based on the guidance in the parts status report in the Online Warranty System (Hold, Return, CORE, Scrap, etc.). Please visit FMCDEALER > PARTS & SERVICE > WARRANTY ADMINISTRATION & WARRANTY PARTS RETURN for the latest [Immediate Scrap List](#) information.
- This process is subject to review during warranty audits for FSA repairs with a repair order open date of March 1<sup>st</sup>, 2021, or later. Any eligible FSA claims requiring parts replacement found not to have been inspected and signed off during a warranty audit will be subject to chargeback and consideration for enrollment into the Dealer Incomplete Recall Repair Process.

**Note:** Other approvals (electronic or handwritten) for add-on repair lines, dealer-owned vehicle repairs, and repeat repairs do not qualify as FSA parts inspection approvals. The post-repair FSA parts inspection process (electronic or handwritten) is independent of other warranty approval requirements. The approval by the designated employee implies that the FSA parts were found to be replaced and must be able to be identified on the Repair Order. If multiple FSAs require approval on a single Repair Order, each applicable occurrence will require individual post-repair approval by the designated employee.

## CERTAIN 2018-2020 MODEL YEAR EXPEDITION AND NAVIGATOR VEHICLES — FRONT SEATBELT RETRACTOR DATE CODE INSPECTION

### **NEW !** SERVICE PROCEDURE

**IMPORTANT!** The Service Technician Specialty Training (STST) Competency 10 certification requirement in the U.S. market only will be enforced starting with repair orders opened on or after August 31, 2024. Field Service Action (FSA) repairs will reject and the claim will not be paid if the repairing technician is not certified in STST Competency 10 FSA. See Electronic Field Communication (EFC)15936 for more details.

### Evaporator Drain Tube Inspection

**⚠ WARNING:** The vehicle should be cool enough to touch before performing this procedure.

1. Using an extension mirror through the Right Hand (RH) side of the engine compartment, inspect the evaporator drain tube for the presence of an elbow installed.

- Is there an elbow installed? See Figure 1 for correct location to inspect and Figure 2 for an example of the elbow installed.

Yes - Passes inspection. Proceed to Front Seatbelt Retractor Inspection procedure, on Page 6.

No - Does not pass inspection. Proceed to Step 2.

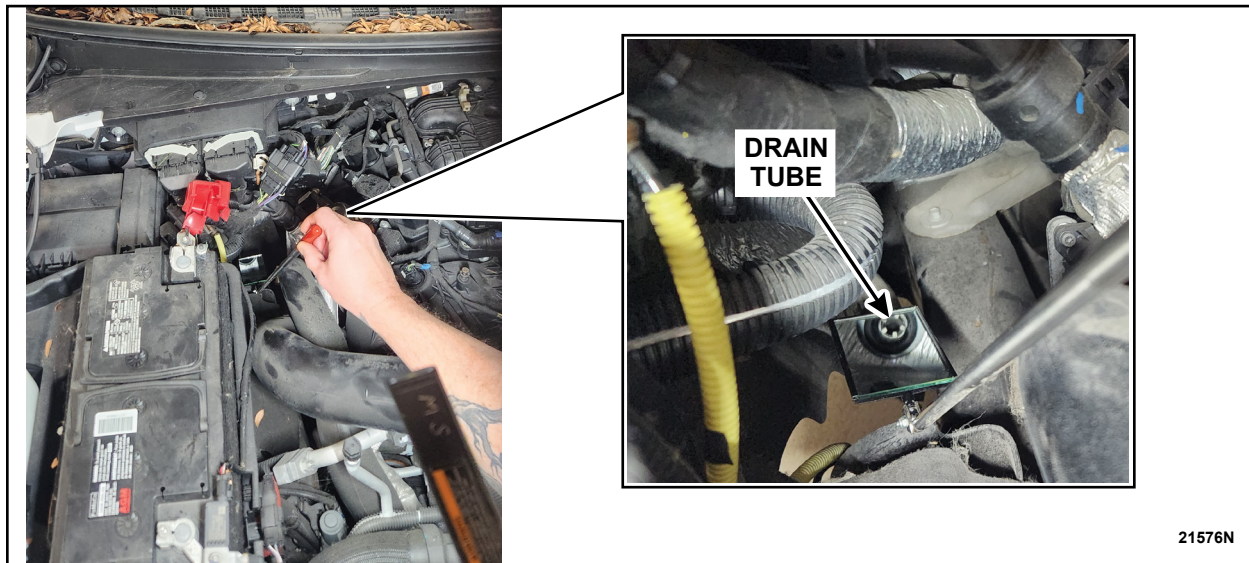
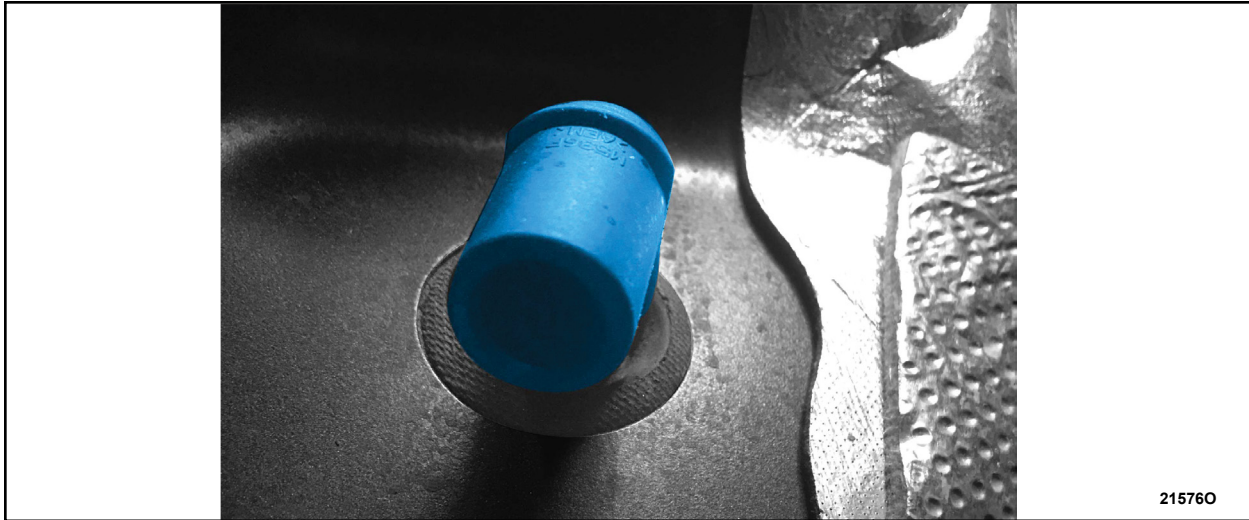

FIGURE 1





**FIGURE 2**

2. Raise the vehicle and remove the RH front tire.
3. Remove the RH front fender splash shield. Follow the Workshop Manual (WSM) procedures in Section 501-02.
4. Using needle nose pliers or equivalent, remove and discard the metal shield from the evaporator drain tube by bending the tabs away from the tube. See Figures 3 through 5.

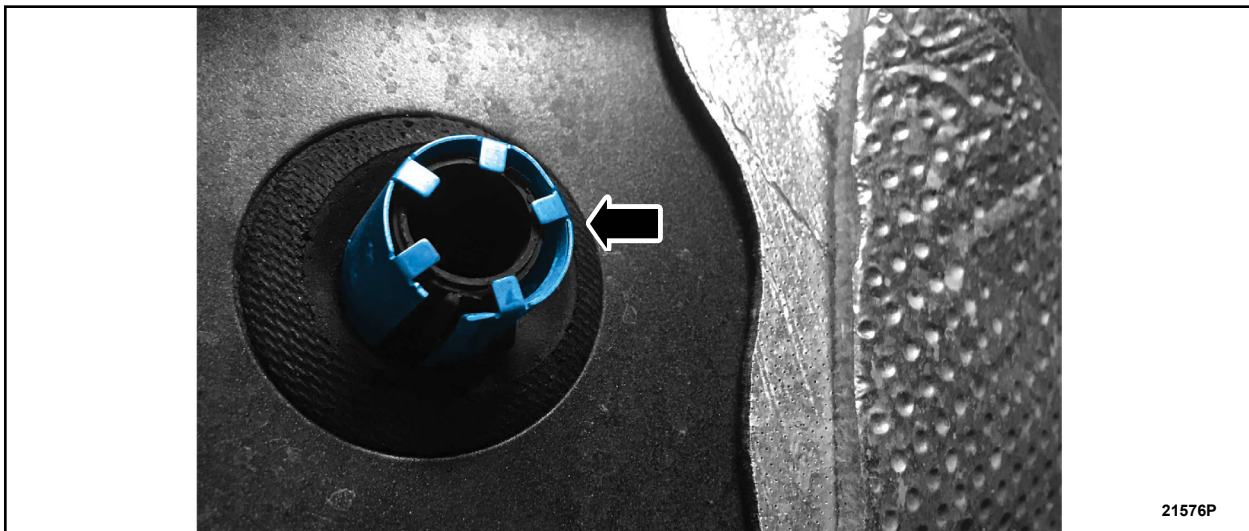

**FIGURE 3**



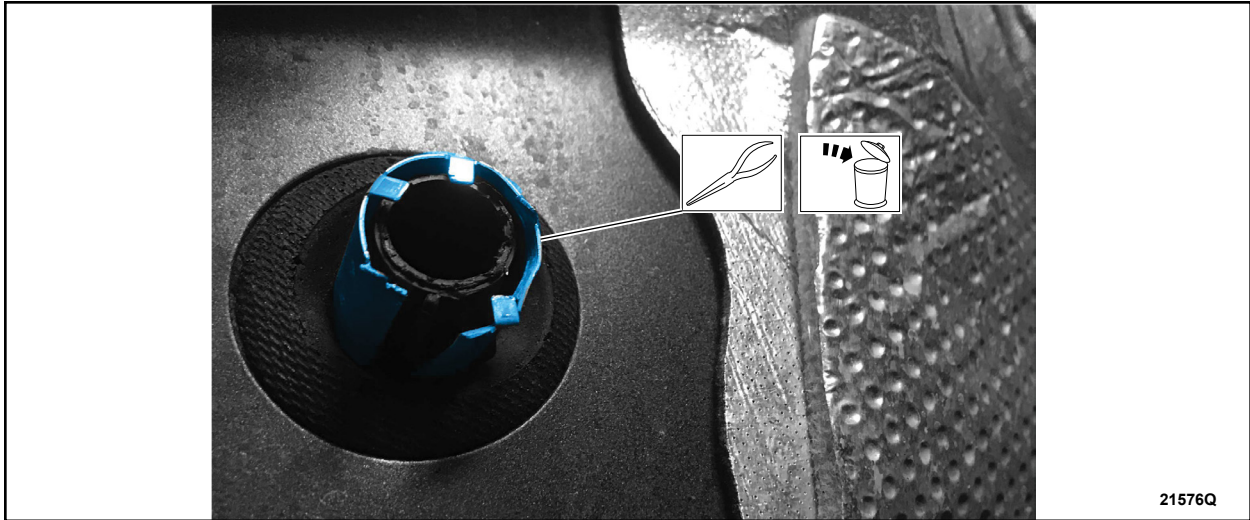

FIGURE 4



FIGURE 5



5. Lubricate the inside of the elbow with water. Install the short end of the elbow onto the drain tube. See Figures 6 and 7.



FIGURE 6

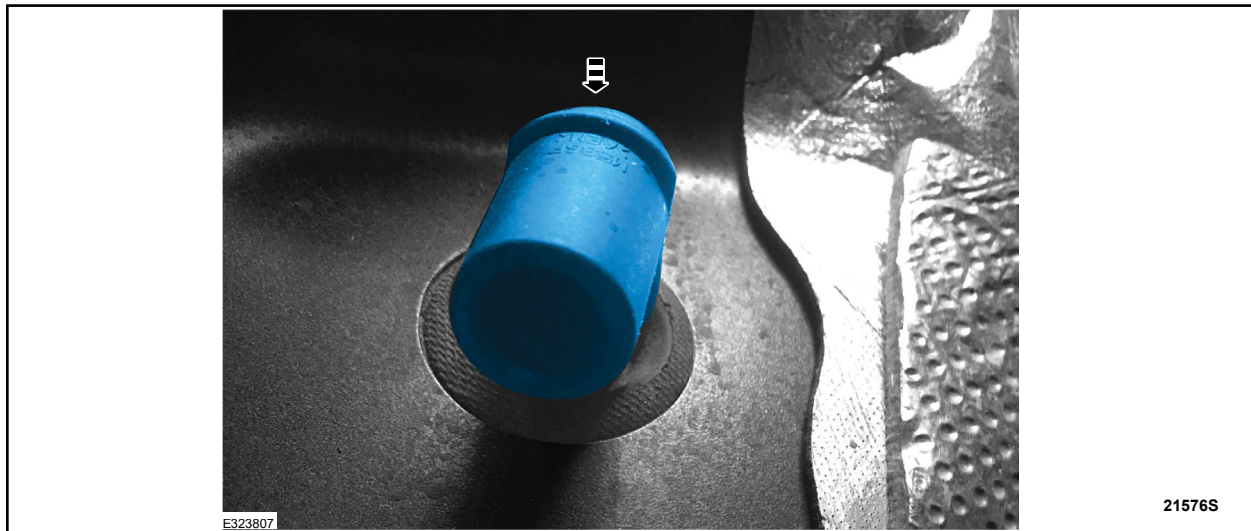

FIGURE 7



6. Clean the surface of the elbow, drain seal, and surrounding sheet metal with isopropyl alcohol or equivalent.
7. Apply heat shield tape over the elbow. See Figure 8.



**FIGURE 8**

8. Reassemble the vehicle by reversing Steps 2 and 3, then proceed to Front Seatbelt Retractor Inspection procedure, on Page 6.

**NOTE: Make sure to inspect the carpet for dampness and/or odor and service as necessary.**



## Front Seatbelt Retractor Inspection

1. Position the front door weatherstrip aside. See Figure 9.

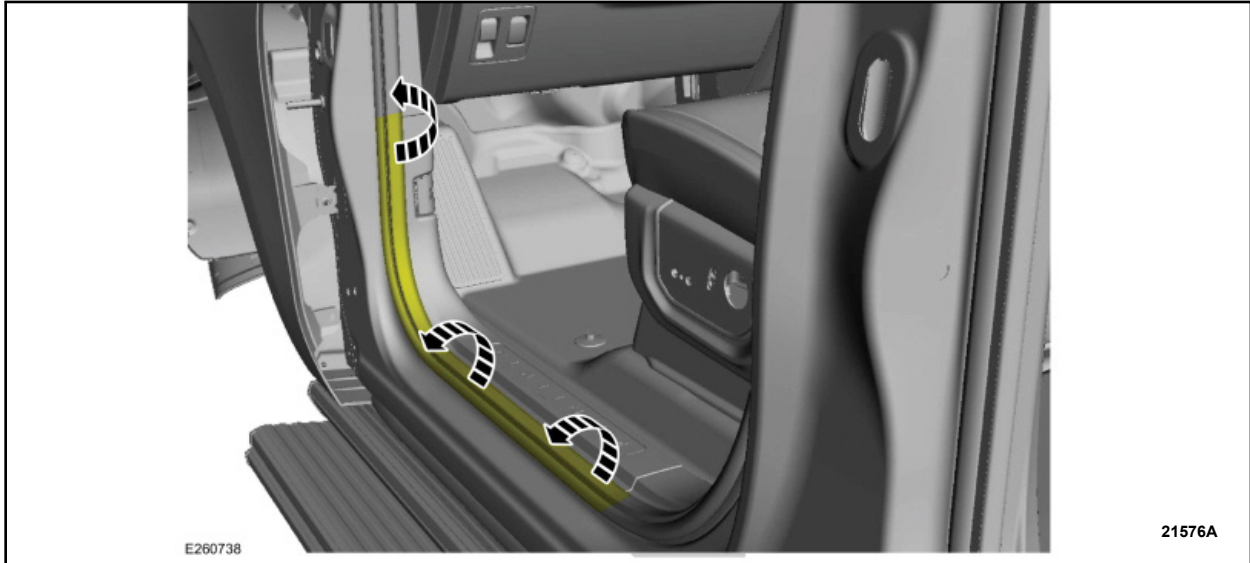

FIGURE 9

2. Release the clips and remove the front door scuff plate trim panel. See Figure 10.

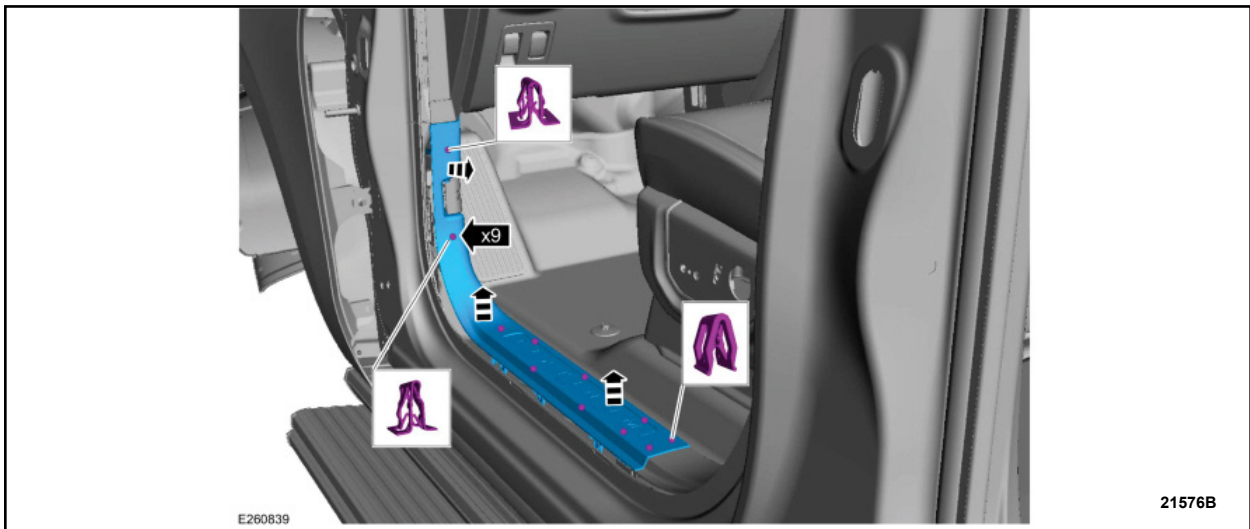
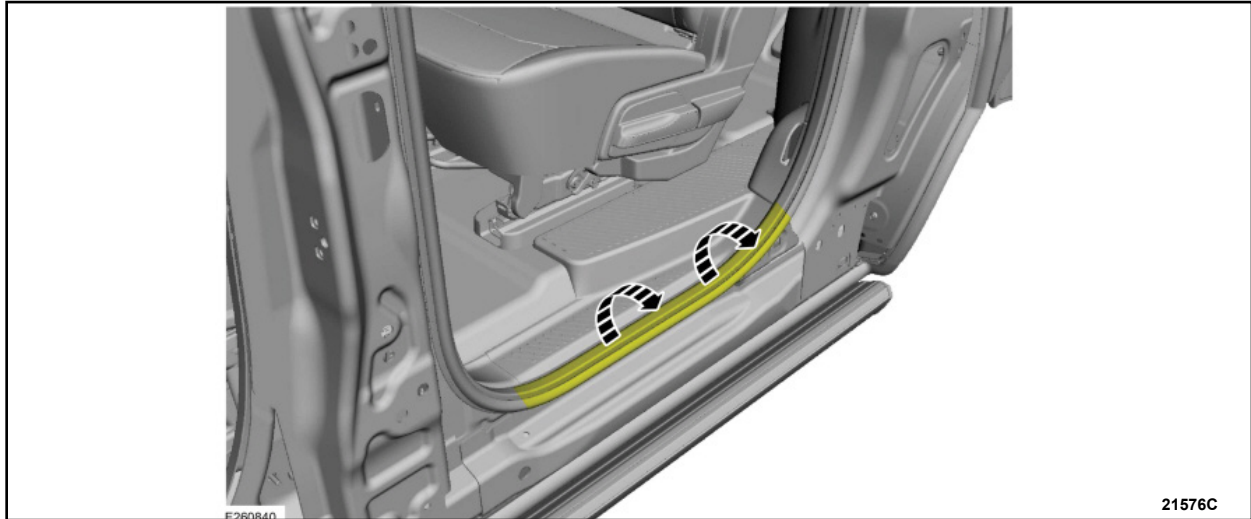

FIGURE 10



3. Position the rear door weatherstrip aside. See Figure 11.



**FIGURE 11**

4. Position the second row seat forward. See Figure 12.

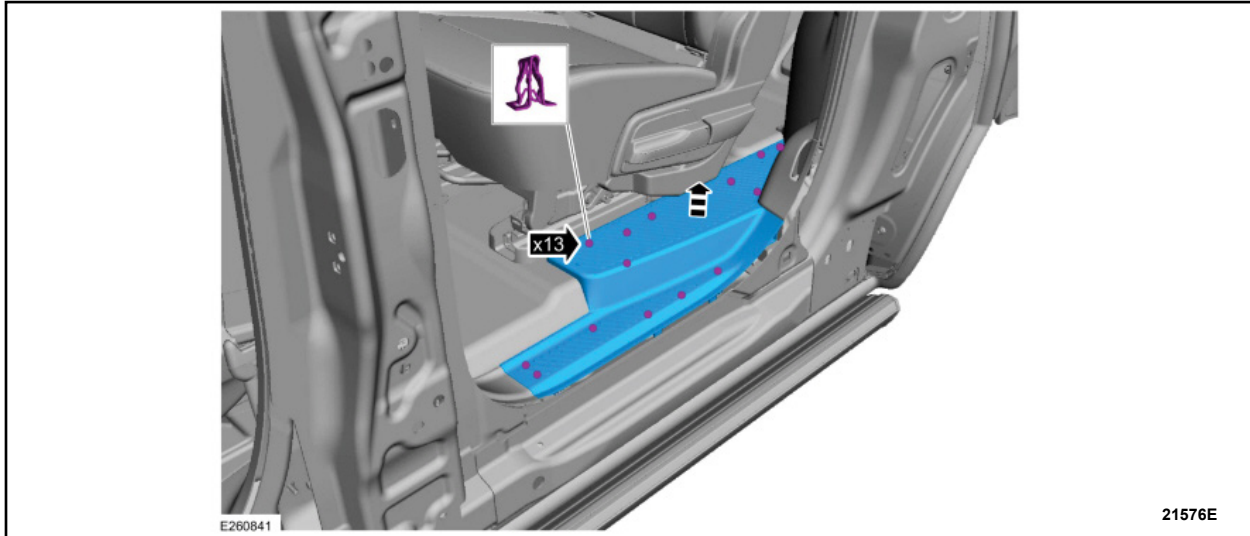

**FIGURE 12**



5. Release the clips and remove the rear door scuff plate trim panel. See Figure 13.

**NOTE:** Long wheelbase shown, short wheelbase similar.



**FIGURE 13**

6. Position the front door weatherstrip aside. See Figure 14.

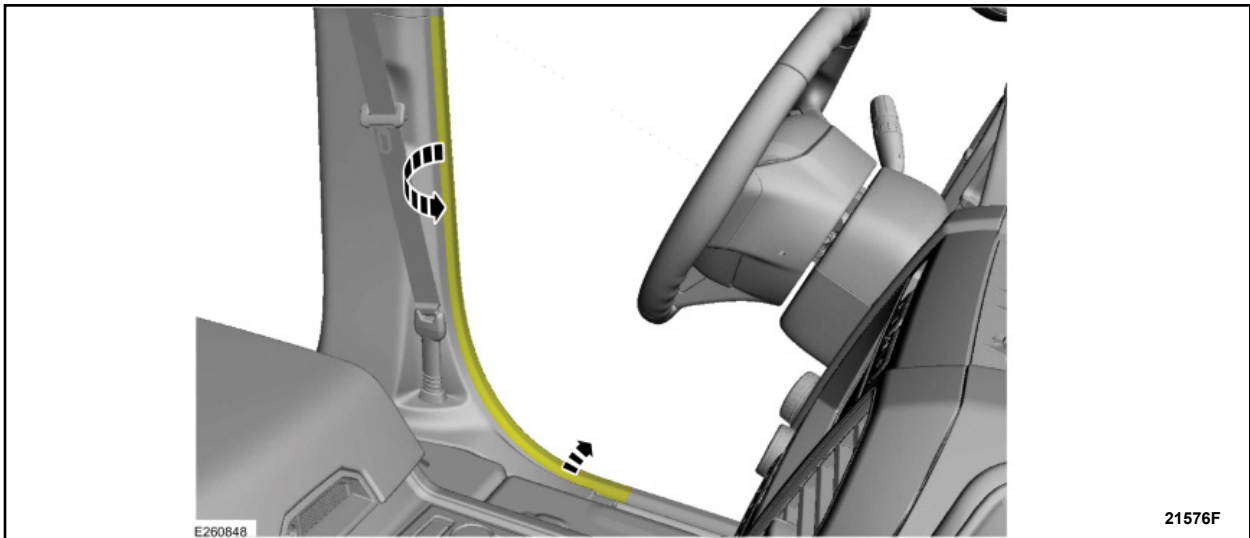

**FIGURE 14**



7. Position the rear door weatherstrip aside. See Figure 15.

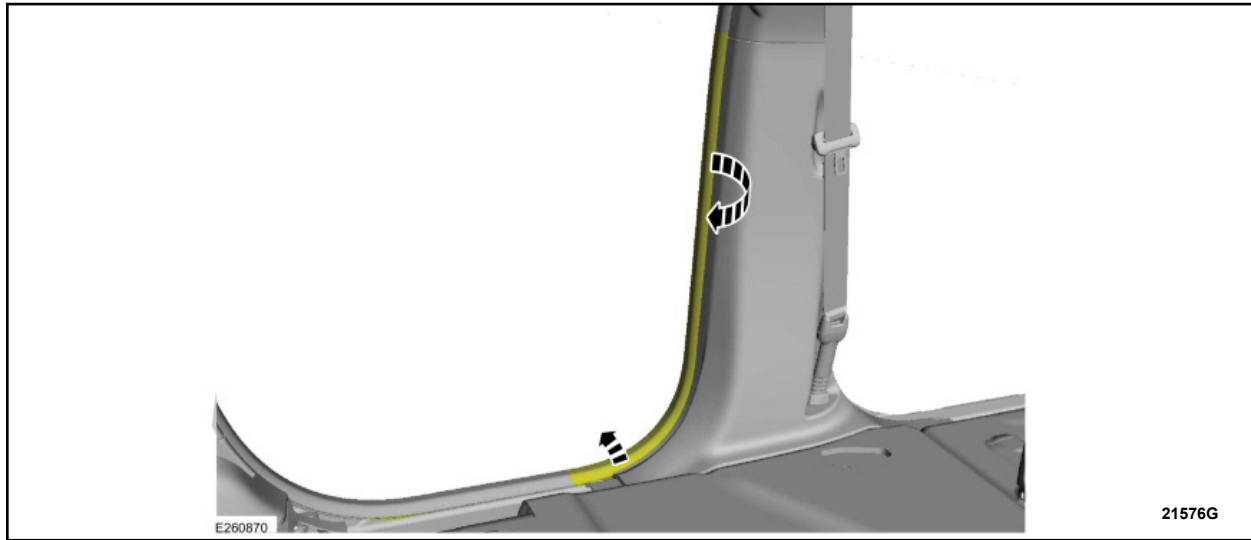

FIGURE 15

8. Press in on the release button and disconnect the front seatbelt retractor from the front seatbelt anchor pretensioner. See Figure 16.

- Use the General Equipment: Flat-Bladed Screwdriver

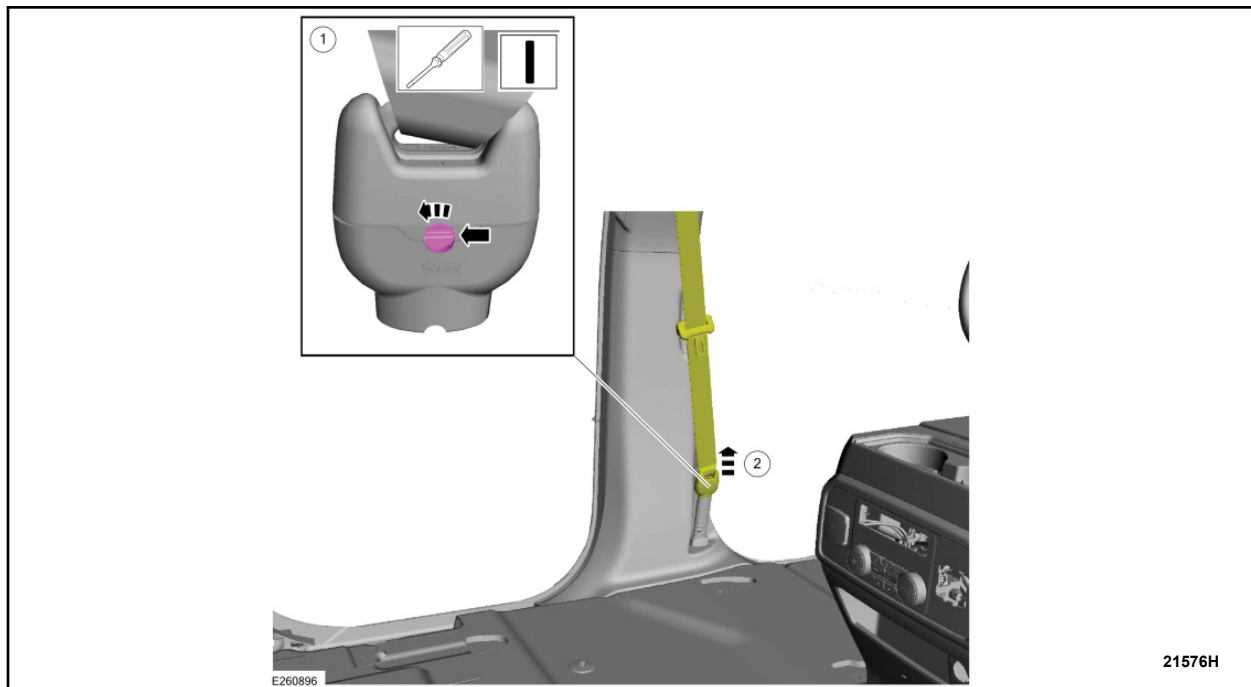
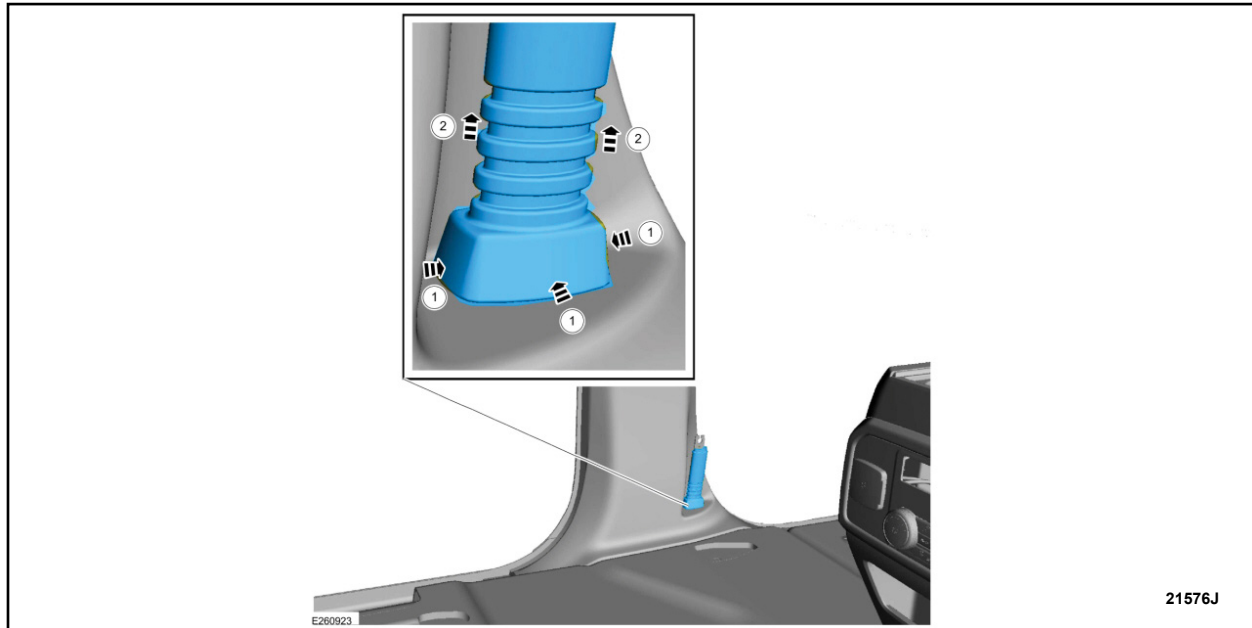

FIGURE 16



9. Press in on the sides of the front seatbelt anchor pretensioner boot, then lift up and remove the front seatbelt anchor pretensioner boot. See Figure 17.



**FIGURE 17**

10. Release the clips and remove the lower B-pillar trim panel. See Figure 18.

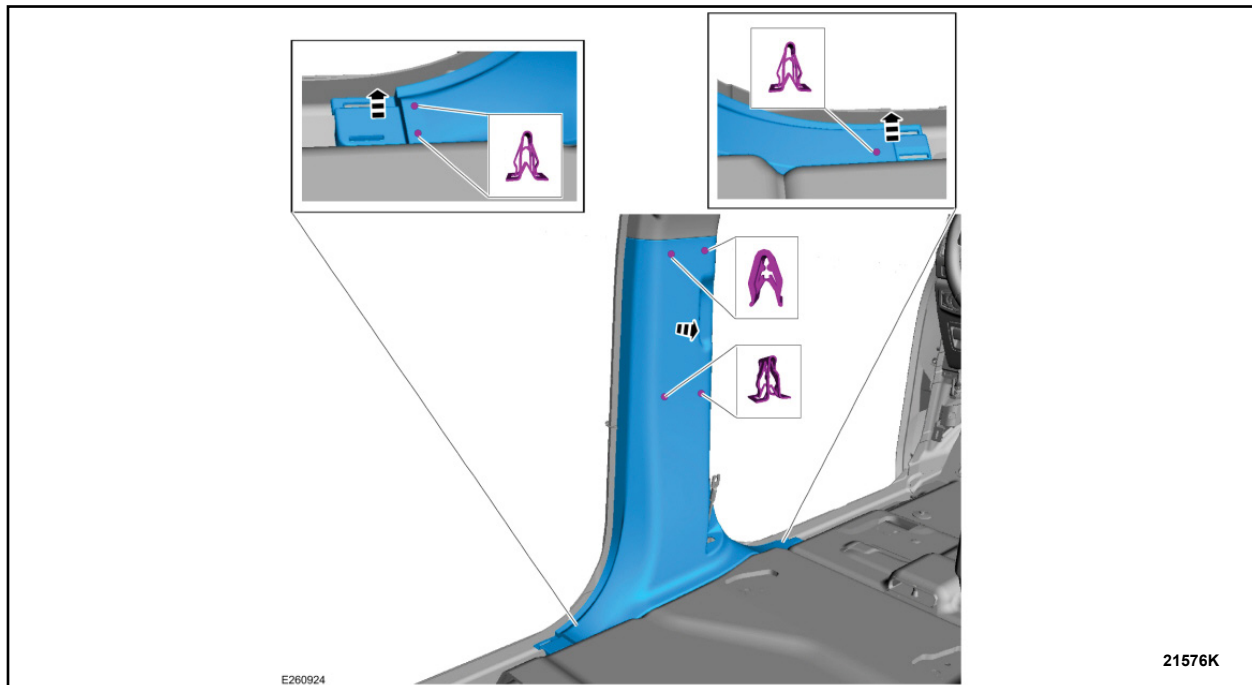

**FIGURE 18**

11. Repeat steps 1 through 10 on the other side of the vehicle.



12. Locate the part label sticker on the back of the Left-Hand (LH) and Right-Hand (RH) front seatbelt retractors. See Figure 19.

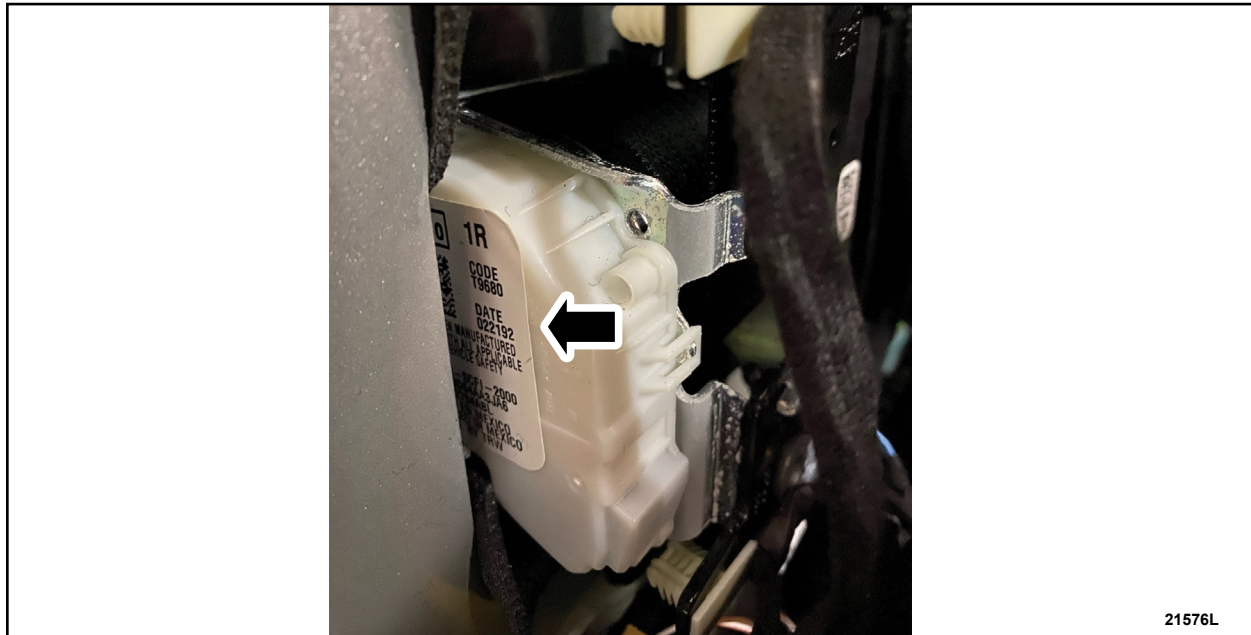

FIGURE 19

13. Locate the date code on both the LH and RH front seatbelt retractors. See Figure 20.

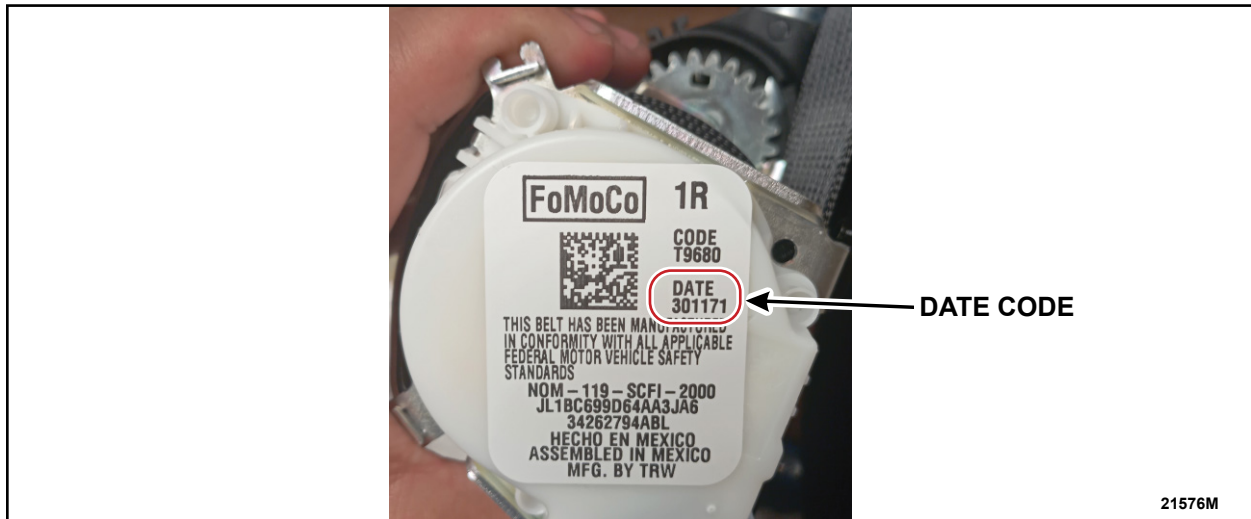

FIGURE 20



14. Do either the LH or RH front seatbelt retractor date codes match any of the following date codes listed in the chart below?

**NOTE: The 3rd digit and the 6th digit of the date codes do NOT need to match.**

Yes - Replace the front seatbelt retractor(s) that have the suspect date codes. Follow the WSM procedures in Section 501-20A.

No - Replacement is not needed. Reinstall the lower B-pillar trim panels by reversing steps 1 through 10, then continue to step 15.

01*19*	23*19*	45*19*	44*18*	13*20*
02*19*	24*19*	46*19*	45*18*	14*20*
03*19*	25*19*	47*19*	46*18*	15*20*
04*19*	26*19*	48*19*	47*18*	16*20*
05*19*	27*19*	49*19*	48*18*	17*20*
06*19*	28*19*	50*19*	49*18*	18*20*
07*19*	29*19*	51*19*	50*18*	19*20*
08*19*	30*19*	52*19*	51*18*	20*20*
09*19*	31*19*	53*19*	52*18*	21*20*
10*19*	32*19*	31*18*	53*18*	22*20*
11*19*	33*19*	32*18*	01*20*	23*20*
12*19*	34*19*	33*18*	02*20*	24*20*
13*19*	35*19*	34*18*	03*20*	25*20*
14*19*	36*19*	35*18*	04*20*	26*20*
15*19*	37*19*	36*18*	05*20*	27*20*
16*19*	38*19*	37*18*	06*20*	28*20*
17*19*	39*19*	38*18*	07*20*	29*20*
18*19*	40*19*	39*18*	08*20*	30*20*
19*19*	41*19*	40*18*	09*20*	31*20*
20*19*	42*19*	41*18*	10*20*	
21*19*	43*19*	42*18*	11*20*	
22*19*	44*19*	43*18*	12*20*	

15. Check the active restraint system for correct operation. Refer to Diagnosis and Testing in WSM Section 501-20A.

**IMPORTANT NOTE: Federal law prohibits selling motor vehicle parts or components that are under safety, compliance, or emissions recall. Unless a part is requested to be returned to Ford, all parts replaced under this FSA must be scrapped in accordance with all applicable local, state and federal environmental protection and hazardous material regulations. Refer to the Parts Retention, Return, & Scrapping section of the FSA dealer bulletin for further information.**

