

DEALER/DISTRIBUTOR SAFETY RECALL NOTICE

Voluntary Recall of Kuat Transfer v2 Bicycle Hitch Rack, Models T201B, T202B, T222B, T223B

June 4, 2024

Kuat Innovations, LLC
2240 N. Alliance Ave.
Springfield, MO 65803

Dear Kuat Dealer,

Kuat Innovations has decided that a defect which relates to motor vehicle safety exists in our Transfer v2 Bicycle Hitch Racks manufactured from November 1, 2020 to March 24, 2024. The pivot cams on these affected Transfer v2 Bicycle Hitch Racks can become disengaged, allowing the bike carrier to drop into the lower position. This malfunction could cause a bicycle to fall off the product while a subject vehicle is in motion, as well as injury or property damage to the product, the bicycle, and to the subject vehicle and other vehicles on the road, including potentially a vehicle crash. The defect may occur without warning. Kuat requests that you stop using and selling these racks immediately until it is determined if the rack is affected by the recall.

PLEASE STOP USING AND SELLING YOUR TRANSFER v2 RACKS IMMEDIATELY. BE ADVISED THAT IT IS A VIOLATION OF FEDERAL LAW TO DELIVER ANY PRODUCT COVERED BY THIS NOTICE TO A CUSTOMER UNTIL THE DEFECT IS REMEDIED.

Before resuming use and sales of your Transfer v2 Racks, please carefully inspect your racks to determine if they are among the units affected by this recall. The Batch IDs of the affected Transfer v2 racks range from 2045 through 2414. The figures below will assist you in identifying the Batch ID of your racks, which is part of the Transfer v2 serial number. The sticker with your product's serial number is located on the outside portion of the U-shaped rack body facing the vehicle, as indicated in Figure 1. Product serial numbers are also located on the external packaging of the Transfer v2 rack. The Batch ID of your unit is the first group of numbers of your serial number, as indicated in Figure 2.



Figure 1

Find your TRANSFER v2 BATCH I.D.

SKU-2045-00000

BATCH I.D.

SKU-2414-00000

BATCH I.D.

Figure 2

If you are unable to locate the Batch ID of your Transfer v2 racks, Figures 3 and 4 below depict the most remarkable, and apparent difference between the defect and the non-defect Transfer racks.

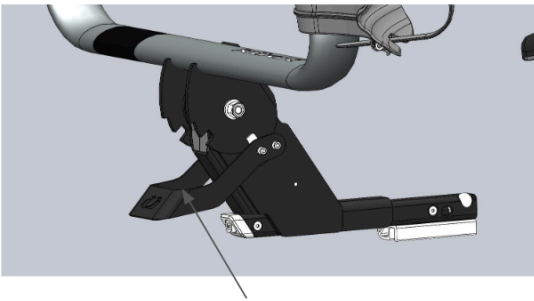

Defect Transfer v2

Figure 3

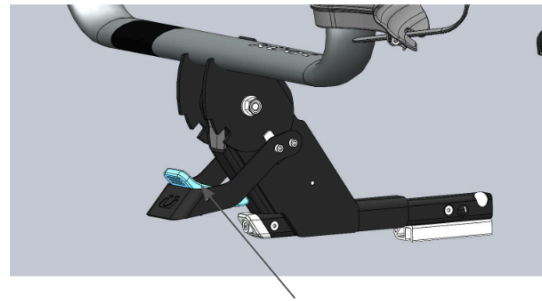

Non-defect Transfer v2

Figure 4

To obtain your free repair kit, please go to www.kuat.com/recalls and follow the instructions for submitting information, or call the Kuat Sales Team toll free at 1(877) 822-5828. Your repair kit will include a new pivot handle assembly, detailed instructions, and all necessary hardware.

We plan to have sufficient repair kits to satisfy the requirements of this recall available as soon as possible. We will notify you of the date of availability for these repair kits as soon as possible. The repair kit will contain all of the necessary parts to remedy the defect and will include detailed instructions. If you have incurred any cost for remedies in advance of this notification please contact the toll free number listed above for reimbursement. Reasonable supporting documentation will be requested.

If you feel that we did not or were unable to provide the remedy within a reasonable amount of time, you may write to the Administrator, National Highway Traffic Safety Administration, 1200 New Jersey Ave. SE, Washington DC 20590, or contact the Vehicle Safety Hotline at (888)327-4236; (TTY: 1(800)424-9153); or go to www.safercar.gov.

Kuat apologizes for any inconvenience this causes. This voluntary recall reflects our commitment to ensure the safety and satisfaction of our customers.

Sincerely,

Kuat Innovations LLC