

Bulletin #: AS-11-24		<input type="checkbox"/> Take Note <input checked="" type="checkbox"/> Take Action	
<input type="checkbox"/> Retail Operator	<input type="checkbox"/> Sales Pre-Owned	<input checked="" type="checkbox"/> Business Manager	<input checked="" type="checkbox"/> Parts & Accessories
<input checked="" type="checkbox"/> General Manager	<input type="checkbox"/> Sales New Bike	<input checked="" type="checkbox"/> Service	<input type="checkbox"/> Administration
Name: Alex Martin		Phone Number:	
Title: Email:		Source: Parts Logistics	
Date: 02/06/2024		Supersedes: -	

TEC611 LED HEADLIGHT PRO

INSPECT OF ALL PARTS ON STOCK

OVERVIEW

- BMW AG has requested the inspection of all dealer stock of the following part number(s) listed below to ensure the change index falls in the acceptable range.

Description	Part Number
LED Headlight Pro	63 12 8 395 642

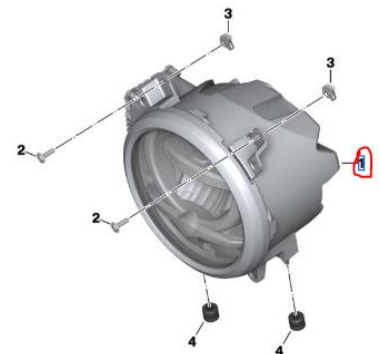

- The image to the right shows the parts as depicted in ETK. Please see below pictures for assistance determining affected stock.
- Remaining stock should not be sold or installed on any vehicle.
- Concerned are all remaining new, spare parts shipped and delivered to date only.
- Please return all incorrect part(s) to your facing Regional Distribution Center (RDC). Submit for return using a YR26 damage claim with order reason BM2. A valid BMW delivery and delivery item number must be entered, and 'TEC611' must appear in the text of your TEC claim. For assistance locating the delivery number, please open an IDS ticket with Dealer Services in the Claims section directed to Returns/Claims/Quality.

MORE DETAILS

MAKE LIFE A RIDE



BMW MOTORRAD

- TEC611 is valid from February 6, 2024, through February 20, 2024. The deadline for filing a claim under TEC611 is March 5, 2024.
- All parts must be returned to your facing RDC no later than March 19, 2024.
- Please re-order the new part as needed.

<p style="text-align: center;">Affected Parts (NOT OK)</p> <p style="text-align: center;">all parts to AI06</p>	<p style="text-align: center;">Non Affected Parts (OK)</p> <p style="text-align: center;">NAEL/AI07 New + Yellow Dot</p> 
---	---

MORE QUESTIONS?

Aftersales Business Development Manager		
Material Planning and Parts Logistics Analyst		
Aftersales Marketing Specialist		

MAKE LIFE A RIDE