

SOP12388

Recall QAAR 10438 Truma Air Conditioner Power Supply Grommet

Department: 32
 People Required: 1
 Time to Complete: 0.30 hours
 Date Created: Nov. 08/23
 Date Revised: Rev #:
 Created by Initial: GK Verified: BH

Supplied Items:

1ea. 3/4" x 50mm tall Split Grommet 118-6502



2ea. #8x3/4" self tapping screws 141-0092

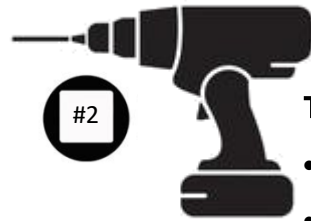

#2

Tools required:

- Cordless drill
- #2 square driver bit
- 6mm hex drive socket
- Inch pound torque wrench

6mm

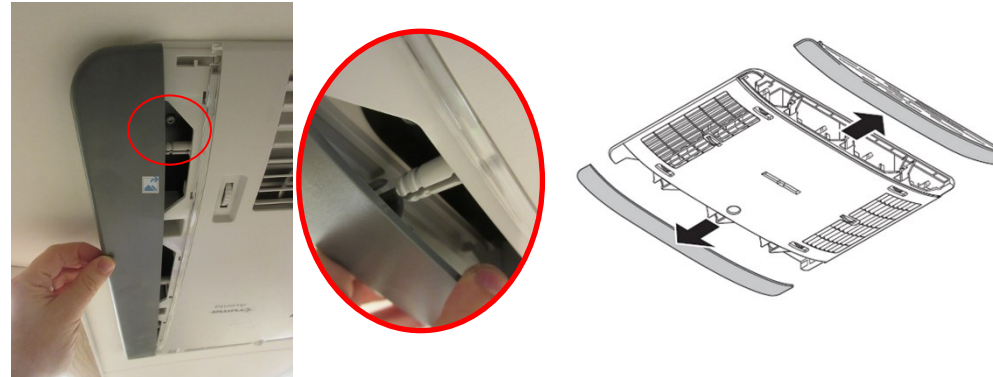

Remove both side panels on the air conditioner diffuser housing by sliding sideways.

1

2

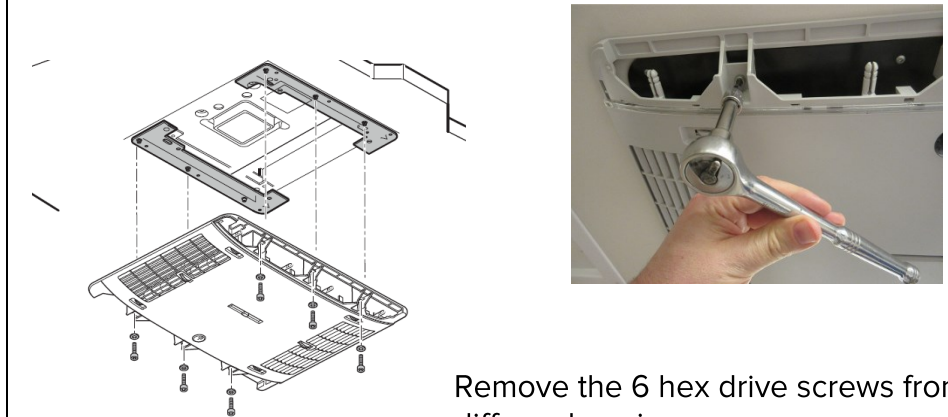

Remove the 6 hex drive screws from the diffuser housing.

3

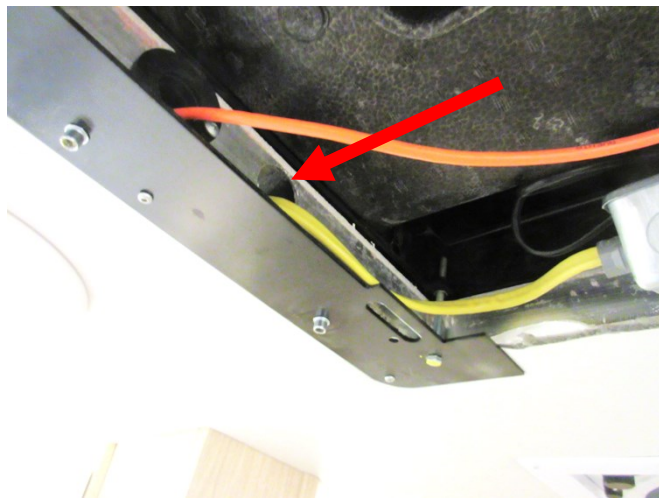

Verify the yellow 12/2 NMD wire is missing a grommet where it runs into the roof frame.
 If grommet is present no corrective action is required, proceed to step #7.

4

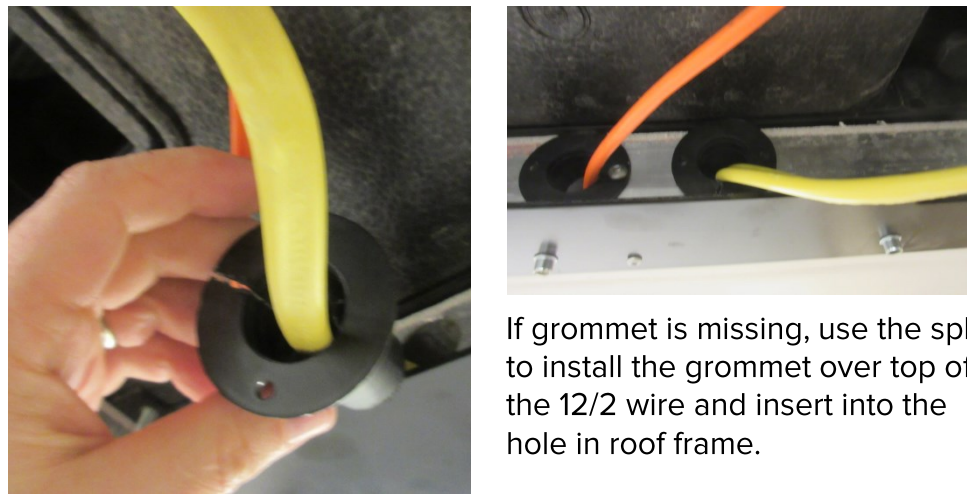

If grommet is missing, use the split to install the grommet over top of the 12/2 wire and insert into the hole in roof frame.

5



Secure grommet in place with the two self-tapping screws into the frame.

6

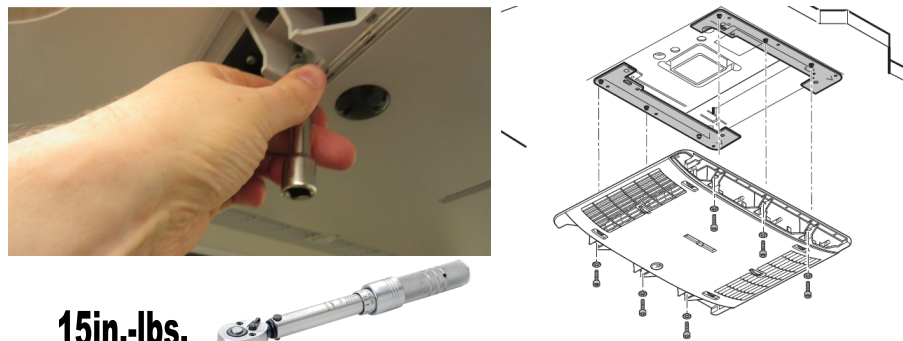

15in.-lbs.



Reinstall the diffuser housing starting all the hex drive screws by hand to prevent cross threading.
 Torque each hex head to 15inch lbs.

7

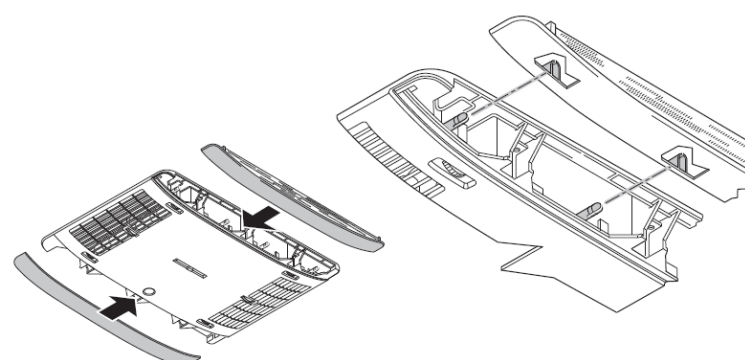

Reinstall both side panels to the side of the air diffuser.

8



Contact Leisure Travel Vans Customer Service/Warranty for questions or technical assistance at:

1-877-992-9906

Or

Recalls@Tripleerv.com

9