

**December 19, 2023**

Version 3

**Safety Recall: 2023–24 HR-V Front Seat Belt Pretensioner Inspection**

Supersedes 23-099, dated November 29, 2023, to revise the information

**AFFECTED VEHICLES**

Year	Model	Trim Level	VIN Range
2023–24	HR-V	ALL	Check the VIN status for eligibility.

**REVISION SUMMARY**

Some images were enhanced throughout the bulletin.

**BACKGROUND**

During manufacturing, some front seat belt pretensioners may have been assembled without a rivet securing the quick connector and wire plate, resulting in front seat belts not functioning as designed, increasing the risk of injury.

**CUSTOMER NOTIFICATION**

Owners of affected vehicles will be sent a notification of this safety recall.

Do an iN VIN status inquiry to verify eligibility.

Some vehicles affected by this campaign may be in your new or used vehicle inventory.

Failure to repair a vehicle subject to a recall or campaign may subject your dealership to claims or lawsuits from the customer or anyone else harmed as a result of such failure. To see if a vehicle in inventory is affected by this safety recall, do a VIN status inquiry before selling it.

**CORRECTIVE ACTION**

Inspect both front seat belt pretensioners and, if necessary, replace them.

**TOOLS INFORMATION**

Part Name	Part Number	Quantity
Pull Force Gauge	07AAJ-30AA100	1

NOTE: This special tool was auto-shipped to all dealers in November 2023.

**PARTS INFORMATION**

Part Name	Part Number	Quantity
Pretensioner Assembly Left Front Lap (Outer)	81825-3W0-A01ZA	1
Pretensioner Assembly Right Front Lap (Outer)	81425-3W0-A01ZA	1

**CUSTOMER INFORMATION:** The information in this bulletin is intended for use only by skilled technicians who have the proper tools, equipment, and training to correctly and safely maintain your vehicle. These procedures should not be attempted by “do-it-yourselfers,” and you should not assume this bulletin applies to your vehicle, or that your vehicle has the condition described. To determine whether this information applies, contact an authorized Honda automobile dealer.

## WARRANTY CLAIM INFORMATION

Operation Number	Description	Flat Rate Time	Defect Code	Symptom Code	Template ID	Failed Part Number
8545A4	Front seat belt prestensioner(s) inspection only	0.2 hr	6XS00	MG700	A23099A	81825-3W0-A01ZA
8541B2	Replace the driver's side pretensioner (includes inspection)	0.5 hr	6XS00	MG700	A23099B	81825-3W0-A01ZA
8541B3	Replace the passenger side pretensioner (includes inspection and SWS initialize)	0.6 hr	6XS00	MG700	A23099C	81425-3W0-A01ZA
8541B4	Replace both seat belt pretensioners (includes inspection and SWS initialize)	0.9 hr	6XS00	MG700	A23099D	81425-3W0-A01ZA

Skill Level: Repair Technician

## INSPECTION PROCEDURE

NOTE:

- Inspect both right and left side seatbelt buckles.
  - Images shown are the driver's side.
1. Insert the S-hook of the pull force gauge into the seatbelt pretensioner loop to inspect the driver's and passenger's sides.

### DRIVER AND PASSENGER SEATBELT PRETENSIONER INSPECTION



**PULL GAUGE**  
30 kgf (70 lbs.)



2. While wearing eye protection, carefully pull up and apply a load of **30kgf (70 lbs)**

- If the pretensioner quick connector remains intact and **DOES NOT** separate from the pretensioner assembly, no further action is required.
- If the pretensioner quick connector separates from the pretensioner assembly from either the driver or passenger's side, go to the REPAIR PROCEDURE.

**GOOD**



**NO GOOD**



## REPAIR PROCEDURE

NOTE: Make sure the vehicle is in the OFF (LOCK) mode.

1. Move the driver's and/or passenger's front seat to the rearmost position and remove the front seat bolts. (Do Not discard the bolts).

### **DRIVER OR PASSENGER SEAT BOLTS REMOVAL**

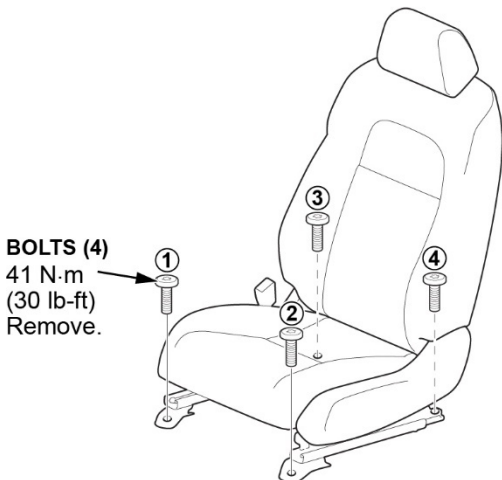

2. Move the driver's and/or passenger's front seat to the forwardmost position and remove the rear seat bolts. (Do Not discard the bolts).

3. Slide the seat forward.

NOTE: Do not remove the seat.

***DRIVER OR PASSENGER'S SEAT***



4. Disconnect the negative cable of the 12-volt battery **4.4 N·m (3.2 lb-ft)**.

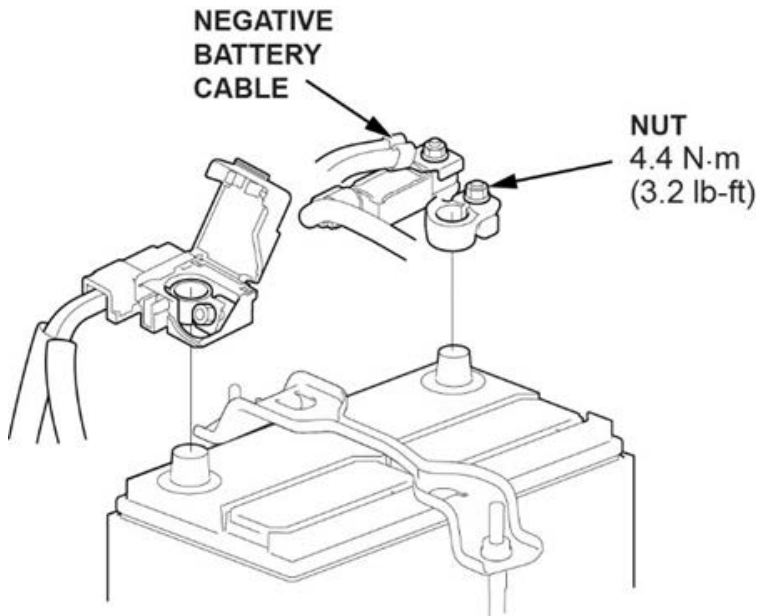

5. Remove the following: driver's side and/or passenger's side lower trim, the rear lower trim, and the center B-pillar trim.

**DRIVER'S SIDE:**

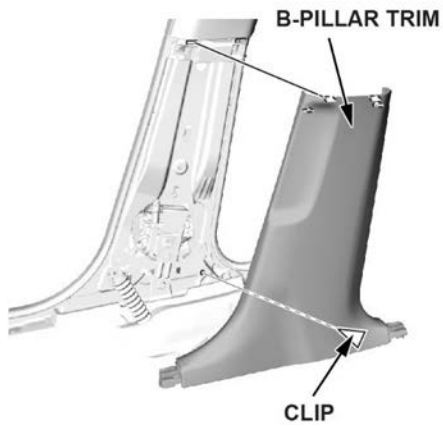
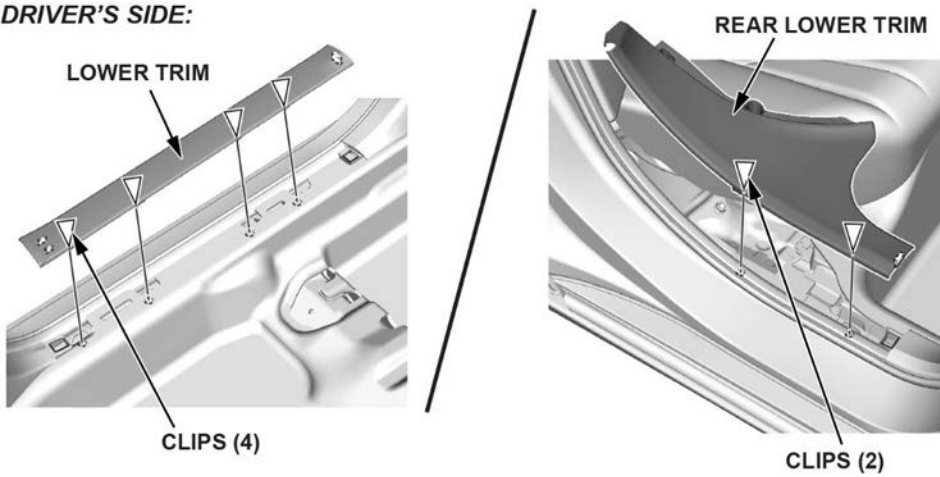

6. Pull back on the carpet as needed to gain access to the seat belt pretensioner bolt.

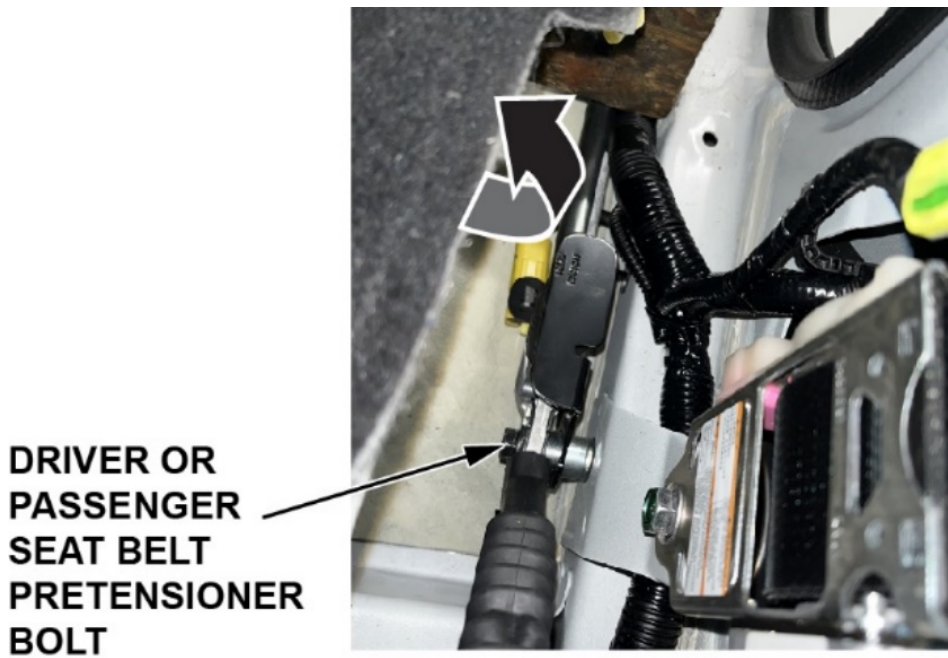

7. Use a small screwdriver to release the seat belt from the quick connector.

**DRIVER OR PASSENGER SEAT BELT QUICK CONNECTOR REMOVAL**

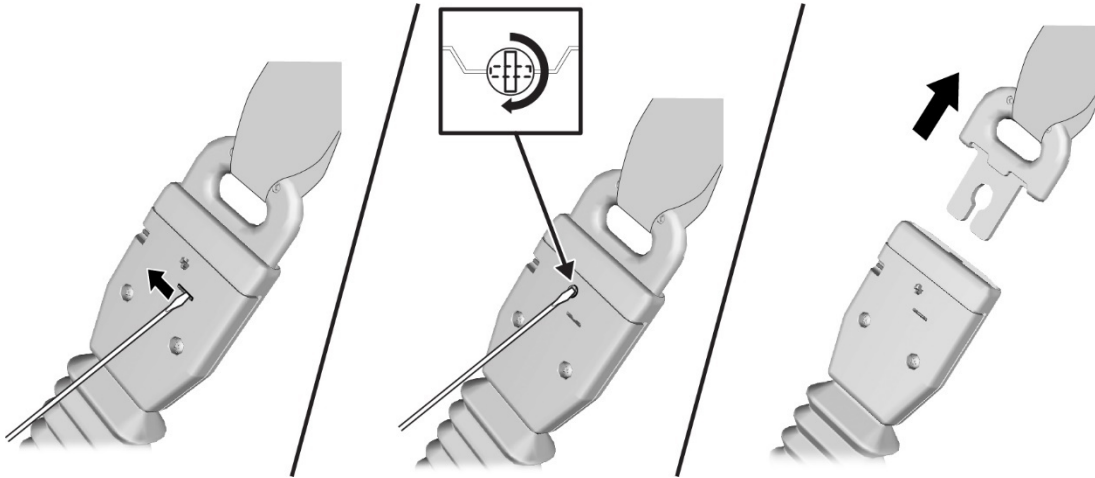

8. Disconnect the driver's and/or passenger's side seat belt outer lap tensioner connector from the floor wire harness.

**DRIVER OR PASSENGER SIDE**

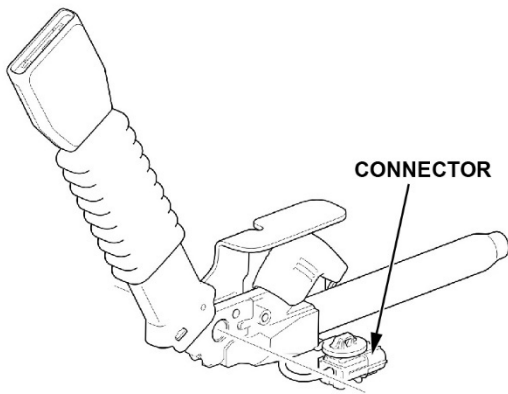

9. Remove the pretensioner mounting bolt, then remove the pretensioner.

**NOTE: Do not** use power tools.

**DRIVER OR PASSENGER SIDE**

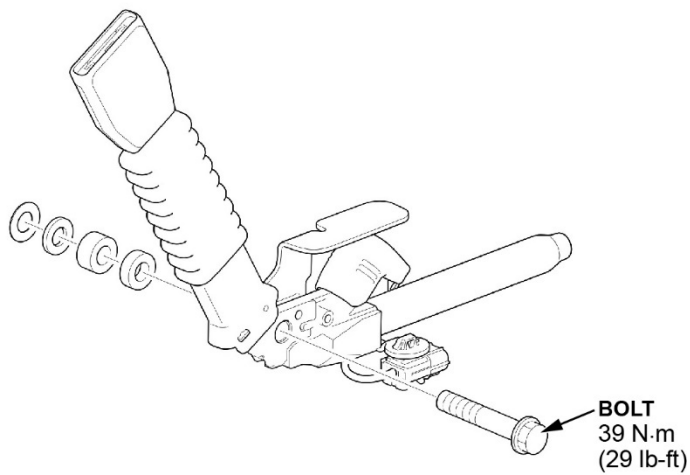

10. Install the new pretensioner and torque the bolt to **39 N·m (29 lb-ft)**.

NOTE:

- **DO NOT** use power tools on installation.
- **DO NOT** reconnect any connectors to the pretensioner unit until fully installed, including torquing the bolts.

11. Connect the connector.

12. Connect the negative cable of the 12-volt battery **4.4 N·m (3.2 lb-ft)**.

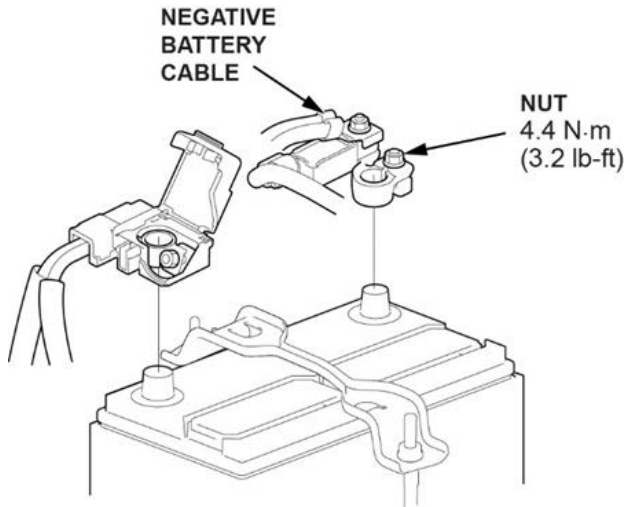

13. Turn the vehicle to the ON mode and check that the SRS indicator comes on for about **6 seconds** and then goes off.

14. Install the trim pieces.

15. Tighten the driver and/or passenger bolts by hand first, then torque them to **41 N·m (30 lb-ft)** in the sequence shown.

NOTE: **DO NOT** use power tools.

***DRIVER OR PASSENGER SEAT BOLTS REMOVAL***

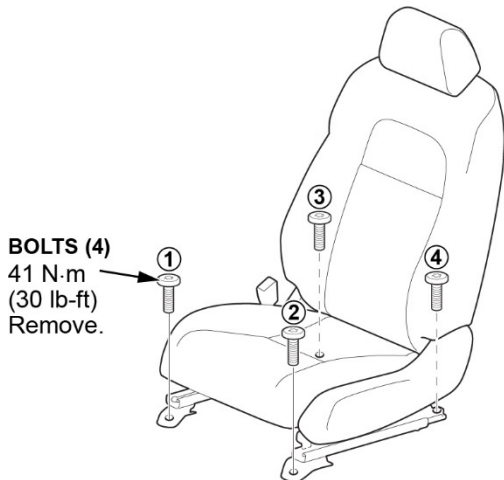

16. Do the Steering Angle Neutral Position Learn procedure.

NOTE:

- Make sure the vehicle is on level ground.
- Make front wheels straight ahead positioned.
- Make sure the i-HDS is connected.
- Do not press the brake pedal during this procedure.

Select the following menu buttons on the i-HDS screen in sequence:

- **ABS/VSA (System Selection Menu)**
- **ADJUSTMENT**
- **ALL SENSOR**

**Front Passenger's Weight Sensor Initialization Procedure (If the passenger's seat belt pretensioner was replaced**

NOTE:

- Make sure the i-HDS is connected.
- Before doing this procedure, clear the DTCs.
- Before doing this procedure, make sure the 12-volt battery is fully charged.
- Make sure the front passenger's seat and all components of the seat are correctly installed.
- Make sure nothing is on the front passenger's seat, including aftermarket seat covers or mats.
- Make sure there is nothing in the front passenger's seat-back pocket.
- Make sure the vehicle is on level ground.
- When you perform this procedure, the vehicle temperature must be between **41- 113 °F (5 - 45°C)**.
- When the vehicle is exposed to intense cold or intense heat, move the vehicle inside open the windows, then perform this procedure after one hour or more.
- Do not expose the front passenger's seat to sudden temperature changes.
- Do not use the A/C and the heater.
- Do not touch the front passenger's seat, and keep the vehicle stationary during this procedure.
- Do not attach the seat belt tongue into the buckle.
- If possible, do all of the above procedures inside.

1. Apply the parking brake.
2. Position the front passenger's seat all the way rearward and lowermost (if equipped with the height adjuster), then adjust the seat-back to the forward most position.

NOTE: Do not move the seat from this position until the initialization is completed.

3. Select the following menu buttons on the i-HDS screen in sequence:

- **SRS (System Selection Menu).**
- **SWS**
- **Adjustment**
- **SWS Initialization**

NOTE: Follow the prompts until the front passenger's weight sensor initialization has been completed.



4. Select the following menu buttons on the i-HDS screen in sequence:

- **SRS (System Selection Menu).**
- **SWS**
- **Data List**
- **FRONT PASSENGER'S WEIGHT**

The weight (T0) of the front passenger's seat is displayed by the i-HDS. Write this measurement down as "T0" on a piece of paper.

NOTE:

- If the reading on the i-HDS (T0) is within  **$\pm 0.35$  kg ( $\pm 0.77$  lbs)**, go to the next step.
- If the reading on the i-HDS (T0) is at or not within  **$\pm 0.35$  kg ( $\pm 0.77$  lbs)**, do the following and repeat the procedure from step 1.

NOTE:

- Confirm that the seat has no interference with surrounding components.
- Remove the front passenger's weight sensors, reinstall them, then repeat this procedure from step 1.
- If after reinstalling the front passenger's weight sensors, the i-HDS (T0) is still at or not within  **$\pm 0.35$  kg ( $\pm 0.77$  lbs)**, replace the front passenger's weight sensors, then repeat this procedure from the beginning.

5. Prepare a weight between **10 kg (22 lbs)–20 kg (44 lbs)**, then measure and note its actual weight (M) with a weight scale.

NOTE:

- The accuracy of the weight scale must be within  **$\pm 1$  kg (2 lbs)**.
- The weight must be uniform in shape and size to allow precise placement on the seat.

6. Precisely place the prepared weight on center of the front passenger's seat as shown.



The weight must be placed precisely on the center line of the seat.

7. From the Data List, select **FRONT PASSENGER'S WEIGHT**. The weight (T) of the front passenger's seat is displayed by the HDS. Write this measurement down as "T" on a piece of paper.

8. Divide (M) by 2. Write this calculation as "M1" on a piece of paper.

9. Calculate the variance between (M1) and the i-HDS (T) with the following formula.

$$\text{Variance} = (T) - (M1)$$

**T: Weight measured by the HDS with the weight on the seat.**

**M1: Half of the weight is measured by the weight scale.**

If the variance is within  **$\pm 2.2$  kg ( $\pm 4.9$  lbs)**, initialization is complete.