

June 12, 2025

Version 13

Safety Recall: 2016–20 MDX Connecting Rod Bearing

Supersedes Version 12, dated March 13, 2025, to revise the information highlighted in **yellow**.

AFFECTED VEHICLES

Year	Model	Trim	VIN Range
2016–20	MDX	ALL	Check iN VIN status inquiry for eligibility

REVISION SUMMARY

This bulletin has been extensively revised; American Honda recommends reviewing this information in its entirety.

Make sure to use the correct application tool and service bulletin to complete this recall:

- If the recall was started using the V-SMART application **on or before June 11, 2025**, continue using the V-SMART application and follow the instructions in the service bulletin linked here: [\(Click HERE\)](#)
- If the repair was started **on or after June 12, 2025**, use the new BEARING INSPECTION application on your American Honda Authorized mobile device and the information in **this** service bulletin. For BEARING INSPECTION application information, refer to this Job Aid: [\(Click HERE\)](#)
- **Do not** use the new BEARING INSPECTION application to complete a repair that was started with V-SMART or vice versa. A warning message will appear indicating the wrong application tool is being used, return to the correct application tool to complete the inspection or repair.

BACKGROUND

On November 9th, 2023, Acura announced a **STOP SALE** and **safety recall** for a certain number of 2016–20 MDX units. These vehicles may have engines containing internal damage at the connecting rod bearings, possibly leading to engine failure. If an engine fails, the vehicle may lose motive power, increasing the risk of crash, fire and resulting injury.

During engine manufacturing, some crankshafts may have been built with improper connecting rod journal dimensions, resulting in increased friction between the journals and their bearings. This increased friction could lead to accelerated engine deterioration and possible failure due to a lack of lubrication and excessive heat.

CLIENT NOTIFICATION

Owners of the affected vehicles will be sent a notification of this campaign.

Perform an iN VIN status inquiry to make sure the vehicle is eligible.

Some vehicles affected by this campaign may be in your new or used vehicle inventory.

Failure to repair a vehicle subject to a recall or campaign may subject your dealership to claims or lawsuits from the client or anyone else harmed as a result of such failure. Before selling a vehicle in inventory, always check if it is affected by a safety recall by performing a VIN status.

IMPORTANT NOTICE

MANDATORY: The self-study training module, *ENC67 - Multiple ConRod Repair with the Bearing Inspection Application*, is available on the Online University. Make sure to complete the module before starting the inspection procedure.

CLIENT INFORMATION: The information in this bulletin is intended for use only by skilled technicians who have the proper tools, equipment, and training to correctly and safely maintain your vehicle. These procedures should not be attempted by “do-it-yourselfers,” and you should not assume this bulletin applies to your vehicle, or that your vehicle has the condition described. To determine whether this information applies, contact an authorized Acura automobile dealer.

CORRECTIVE ACTION

Do an iN **VIN** status inquiry to make sure the vehicle is shown as eligible for an inspection. Removal of the connecting rod bearings and taking/sending photos via the BEARING INSPECTION application for inspection to the Bearing Inspection Inquiry Team are required. This team will conduct a judgment and recommend the appropriate repair for the technician to complete.

In the event that parts are not available, the **STOP SALE** remains in effect for that vehicle. To see if a vehicle in inventory is affected by this safety recall, do a **VIN** status inquiry before selling it. Some vehicles affected by this campaign may be in your new or used vehicle inventory.

PARTS INFORMATION

Repair parts will be automatically allocated based on repair direction.

American Honda Parts will automatically place orders for all parts necessary for this repair. These parts should be visible in iN within **24 hours** of the Bearing Inspection Inquiry.

If replacing the crankshaft the must-replace parts **will not** be shipped until the journal and bore codes from the new crankshaft are sent to the Bearing Inspection Inquiry Team.

Due to shipping constraints, please make sure **all** the required parts are received prior to beginning the repair.

To check the status of the auto-ordered parts, refer to Order Reference Number (for example: SCR0004X) using the code matrix:

- SCR: Standard Connecting Rod
- 0000: Last 4 digits of the VIN
- X: Alpha Character Used for Separate Orders

REQUIRED MATERIALS

Part Name	Part Number	Quantity
0W-20 Full Synthetic Motor Oil	-	5.4 Qt. or 6.4 Qt. (Depending on Repair)
Hondabond HT Silicone Gasket	08718-0004	1 tube per 2 vehicles
Antifreeze / Coolant Type 2	OL999-9011A	8.9 L (2.35 Gal.) (Repair #2, #3, and #4)
Oil Filter	15400-PLM-A02	1 (Repair #3 and #4)
ATF Type 3.1	08200-9017A	1 bottle for 5 cars (Repair #2, #3, and #4)

TOOL INFORMATION

Tool Name	Tool Number	Quantity Per Repair
Bearing Photo Box, [BOX, BEARING PHOTO]	07AAK-5J2A200	1
Photo Box Light Set [SET, PHOTO BOX LIGHT]	07AAK-5J2A210	1 set
M8 Rod Holder, [HOLDER, M8 ROD]	07AAB-5G0A100	1
Crank Angle Gauge, [GAUGE, CRANK ANGLE]	07AAJ-5G0A100	1
Piston Stopper, [STOPPER, PISTON]	07AAB-5G0A200	1 set
Radiator Protector [PROTECTOR, RADIATOR]	07AAK-5A2A100	1
Transmission Pins, [PIN, MISSION ALIGN]	07AAG-5J4A100	1 set
Connecting Rod Guides, [SET, CON ROD TIE DOWN]	07AAB-5G0A300	1 set
Crank Install Guide, [GUIDE, CRANK INSTALL]	07AAG-5J6A100	1
Subframe Guide, [PIN, SUBFRAME GUIDE]	07AAG-TZ3A100	1 set
Subframe Support, [JIG, SUBFRAME SUPPORT]	07AAK-TZ3A100	1
9AT Transmission Cap (CAP, 9AT PROTECTING)	07AAK-5J4A101	1
Engine Stand	78155	1
Engine Stand Crane with Crank Holder Tool	555-80103	1
Engine Stand Adapter Plate	555-80104	1
PARTS CART	PR1-A	1
Rod Bearing Organizer, [ORGANIZER, ROD BRNG]	07AAK-5J2A100	1
Crank Bearing Organizer, [ORGANIZER, CRANK BRNG]	07AAK-R9PA100	1

NOTE:

- These tools have been auto-shipped to your dealer. There is no need to order at this time as quantities are limited. Contact the Special Tools Hotline **(833) 949-4672** and/or email special_tools@ahm.honda.com for information.

Tool Name	Tool Number	Quantity Per Repair
American Honda Authorized Mobile Device	CDW5001003PK	1
Large Zip Tie	Commercially Available	2
LOAD LEVELER	NRI78115H	1
LIFT TABLE	KLS6227500	1
ENGINE BALANCE BAR ATTACHMENT	VSB02C000044 with VSB02C000019	1
LARGE, COMMERCIALY AVAILABLE RUBBER BANDS	-	2
Automatic Center Punch	SKE18A	1

NOTE:

- The Automatic Center Punch has been auto-shipped to your dealer. This tool is commercially available, which can be purchased at most tool supply stores.
- These are existing required tools that dealers should have available. If additional tools are needed, they are available for purchase, contact the Tool and Equipment Program at **(888) 424-6857** and/or email AHMTE@snapon.com

WARRANTY CLAIM INFORMATION

Important Notice:

- Warranty claim information extends across multiple pages; please select the correct table.
- For repair method other than Connecting Rod Bearing replacement, the repair must be matched with the appropriate inspection and repair template to process the warranty claim.
- The Bearing Inspection Inquiry Team will send an email to the address provided containing a summary of the failed part numbers and the corresponding warranty codes to use.

INSPECTION A, plus repair

NOTE:

- For inspections that resulted in a repair, you will need to create **two repair lines** in the repair order- **one for inspection** and **one for repair**.
- Both repair lines must be done for completion of **this claim**.
- Enter the bearing part number(s) (provided by the Bearing Inspection Inquiry Team) under templates D.

Operation Number	Description	Flat Rate Time	Defect Code	Symptom Code	Template ID	Failed Part Number
1115G5	Inspection A- connecting rod bearings (includes photos)	1.7 hr	6JA00	THS00	B24001A	13010-R9P-A00
1111ER	Replace connecting rod bearings (includes photos)	2.3 hr	6KC00	OH600	B24001D	13321-5J6-A01

INSPECTION B, plus repair

NOTE:

- For inspections that resulted in a repair, you will need to create **two repair lines** in the repair order- **one for inspection** and **one for repair**.
- Both repair lines must be done for completion of **this claim**.
- Enter the bearing part number(s) (provided by the Bearing Inspection Inquiry Team) under templates E.

1115G6	Inspection B – connecting rod bearings and main cap bearing (includes photos)	2.7 hr	6JA00	THS00	B24001B	13050-R9P-A00
1111FM	Replace connecting rod bearings (includes photos)	2.3 hr	6KC00	OH600	B24001E	13341-R9P-A01

VIN and Engine Number Identification Query through application tool—No Repair

NOTE:

- No further warranty claim required; vehicle is considered fixed by engine number verification.
- Use only this labor operation if the engine number identification query through the application tool was done and resulted in “*Engine Not Affected.*”
- Do not use this warranty table for either Inspection A or Inspection B.
- Complete the warranty claim using the application with warranty codes.

1115G2	Inspect VIN/EIN Engine not affected (Includes contacting the Bearing Inspection Inquiry Team)	0.3 hr	6KC00	OH600	B24001C	11200-5J6-A11
--------	---	--------	-------	-------	---------	---------------

INSPECTION A or B

NOTE:

- For repair method other than Connecting Rod Bearing replacement, the repair must be matched with the appropriate inspection and repair template to process the warranty claim.
- For inspections that resulted in a repair, you will need to create **two repair lines** in the repair order- **one for inspection** and **one for repair**.
- Both repair lines must be done for completion of **this claim**.

Operation Number	Description	Flat Rate Time	Defect Code	Symptom Code	Template ID	Failed Part Number
1115G5	Inspection A- connecting rod bearings (includes photos)	1.7 hr	6JA00	THS00	B24001A	13010-R9P-A00
1115G6	Inspection B – connecting rod bearings and main cap bearing (includes photos)	2.7 hr	6JA00	THS00	B24001B	13050-R9P-A00

Crankshaft Replacement

NOTE:

- For inspections that resulted in other than a connecting rod replacement, you will need to create **two repair lines** in the repair order- **one for inspection** and **one for repair**.
- Based on the Bearing Inspection Inquiry Team’s recommended repair, select the appropriate repair template below.
- Both repair lines must be done for completion of **this claim**.

FWD

1111EY	Replace crankshaft (includes alignment)	9.2 hr	6KC00	OH600	B24001F	13322-5J6-A01
--------	--	--------	-------	-------	---------	---------------

AWD

1111EY	Replace crankshaft (includes alignment)	9.3 hr	6KC00	OH600	B24001G	13322-5J6-A01
--------	--	--------	-------	-------	---------	---------------

AWD with ATF Cooler

1111FC	Replace crankshaft with ATF Cooler (includes alignment)	9.7 hr	6KC00	OH600	B24001H	13212-R70-D01
--------	---	--------	-------	-------	---------	---------------

Crankshaft Replacement Including Oil Pump, Strainer, and Base

NOTE:

- For inspections that resulted in other than a connecting rod replacement, you will need to create **two repair lines** in the repair order- **one for inspection** and **one for repair**.
- Based on the Bearing Inspection Inquiry Team's recommended repair, select the appropriate repair template below.
- Both repair lines must be done for completion of **this claim**.

FWD

1111EZ	Replace crankshaft, pump, strainer, base (includes alignment)	9.2 hr	6KC00	OH600	B24001J	13323-5J6-A01
--------	---	--------	-------	-------	---------	---------------

AWD

1111EZ	Replace crankshaft, pump, strainer, base (includes alignment)	9.3 hr	6KC00	OH600	B24001K	13323-5J6-A01
--------	---	--------	-------	-------	---------	---------------

AWD with ATF Cooler

1111FD	Replace crankshaft, pump, strainer, base, with ATF Cooler (includes alignment)	9.7 hr	6KC00	OH600	B24001L	13213-R70-D01
--------	--	--------	-------	-------	---------	---------------

Long Block Replacement

NOTE:

- For inspections that resulted in other than a connecting rod replacement, you will need to create **two repair lines** in the repair order- **one for inspection** and **one for repair**.
- Based on the Bearing Inspection Inquiry Team's recommended repair, select the appropriate repair template below.
- Both repair lines must be done for completion of **this claim**.

FWD

1111FE	Replace long block (includes alignment)	10.1 hr	6KC00	OH600	B24001M	13324-5J6-A01
--------	---	---------	-------	-------	---------	---------------

AWD

1111FE	Replace long block (includes alignment)	10.2 hr	6KC00	OH600	B24001N	13324-5J6-A01
--------	---	---------	-------	-------	---------	---------------

AWD with ATF Cooler

1111FF	Replace long block, with ATF Cooler (includes alignment)	10.6 hr	6KC00	OH600	B24001P	13214-R70-D01
--------	--	---------	-------	-------	---------	---------------

Inspection Procedure for Complete Engine Failure

NOTE:

- For complete engine failure inspection, you will need to create **two repair lines** in the repair order- **one for inspection** and **one for repair**.
- Based on the Bearing Inspection Inquiry Team's recommended repair, **select inspection template Q** and appropriate repair template below.
- Both repair lines must be done for completion of **this claim**.

Operation Number	Description	Flat Rate Time	Defect Code	Symptom Code	Template ID	Failed Part Number
1115G7	Inspect for broken connecting rod only (includes photos)	0.5 hr	6JA00	THS00	B24001Q	11221-5G0-A00

FWD

1111FE	Replace long block (includes alignment)	10.1 hr	6KC00	OH600	B24001R	13324-5J6-A01
--------	---	---------	-------	-------	---------	---------------

AWD

1111FE	Replace long block (includes alignment)	10.2 hr	6KC00	OH600	B24001S	13324-5J6-A01
--------	---	---------	-------	-------	---------	---------------

AWD with ATF Cooler

1111FF	Replace long block, with ATF Cooler (includes alignment)	10.6 hr	6KC00	OH600	B24001T	13214-R70-D01
--------	--	---------	-------	-------	---------	---------------

Skill Level: Repair Technician

NOTE: Repair will require a special code that has been emailed by the Bearing Inspection Inquiry Team.

CONTENT REFERENCE

Important Notice

NOTE: DO NOT contact Tech Line for any inquiries about this safety recall. If instructed by the application tool, call the Bearing Inspection Inquiry Team at (800) 824-6632 (**Select Option #9**).

This information has been designed to work best when viewing through iN. It is **strongly suggested** (due to final page count and complexity) that the technician use iN to fully utilize this service bulletin's functions.

Furthermore, the technician is also advised to prepare their workstation for the tasks ahead. This includes: An American Honda Authorized mobile device that is fully charged, tools laid out, verify strong connection to Wi-Fi, and access to this service bulletin in its entirety via iN.

For BEARING INSPECTION application instruction, refer to this Job Aid: [\(Click HERE\)](#)

TABLE OF CONTENTS

ENGINE NUMBER VERIFICATION	9
INSPECTION A	10
INSPECTION B	356
REPAIR #1 INSTALL RECOMMENDED BEARINGS	70
REPAIR #2 – LONG BLOCK REPLACEMENT	92
REPAIR #3 and #4 CRANKSHAFT REPLACEMENT	102
SUBFRAME INSTALLATION	115

NOTE: **Click** on a section title to go there.

ENGINE NUMBER VERIFICATION

NOTE: DO NOT contact Tech Line for any inquiries about this safety recall. If instructed by the application tool, call the Bearing Inspection Inquiry Team at (800) 824-6632 (**Select Option #9**).

1. Remove the engine cover for better access to the engine number.

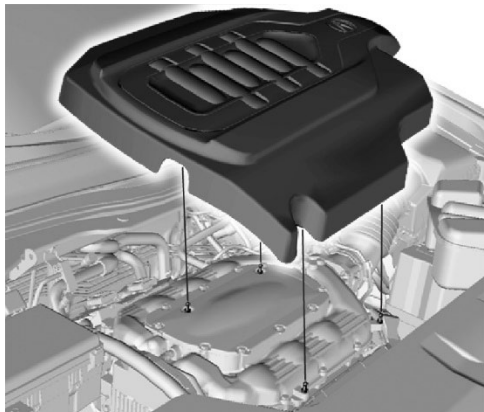

2. Locate the engine identification number.

NOTE: If the number is not legible, clean the surface.

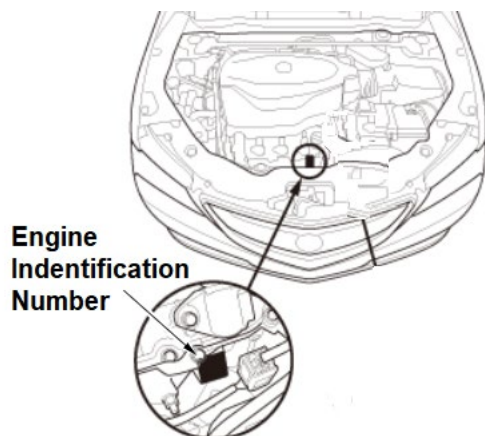

3. Log into the BEARING INSPECTION application and scan or manually enter the VIN, then enter the RO#.

NOTE: For BEARING INSPECTION application instruction, refer to this Job Aid: [\(Click HERE\)](#)

4. Use the BEARING INSPECTION application to capture a photo of the engine serial number.

Once the engine number has been confirmed by the BEARING INSPECTION application, proceed to either **INSPECTION A** or **INSPECTION B**.

- Link to **INSPECTION A**, [\(Click HERE\)](#)
- Link to **INSPECTION B**, [\(Click HERE\)](#)

INSPECTION A

NOTE: DO NOT contact Tech Line for any inquiries about this safety recall. If instructed by the application tool, call the Bearing Inspection Inquiry Team at (800) 824-6632 (**Select Option #9**).

1. Turn the steering wheel all the way to the right.
2. Relieve the fuel pressure.

With the i-HDS:

1. Connect an interface tool to the data link connector (DLC) located under the driver's side of the dashboard and launch i-HDS.

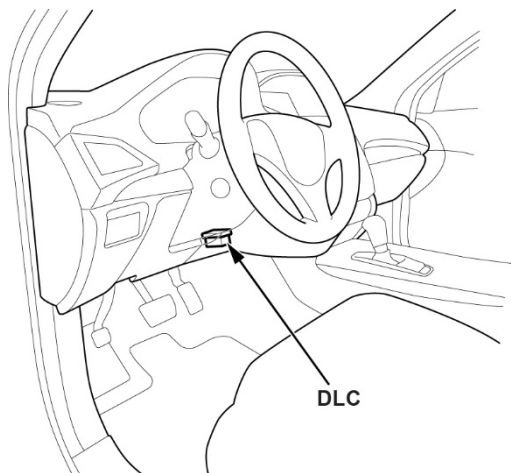

2. Turn the vehicle to ON.
3. Select the **PGM-FI** system on the i-HDS.
4. Select **FUEL PUMP OFF** from the **Inspection Menu** and follow the on screen instructions.

Without the i-HDS:

1. Remove the PGM-FI main relay 2 from the under-dash fuse/relay box.

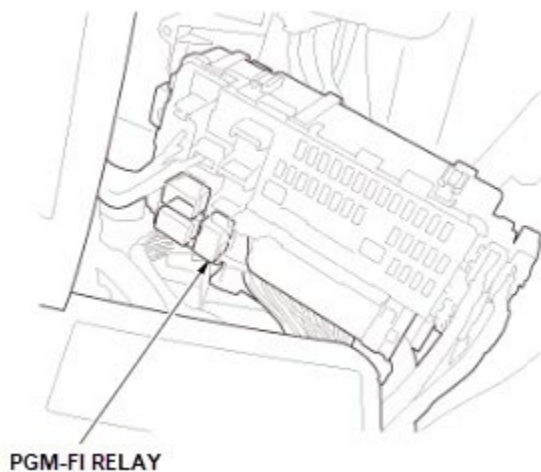

2. Start the engine and let it idle until it stalls.
3. Turn the vehicle to OFF.
4. Install the PGM-FI main relay 2.

3. Remove the front bulkhead cover.

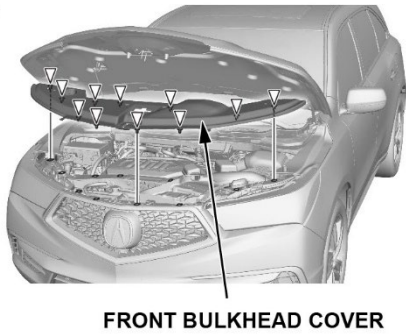

4. Remove the air intake tube.

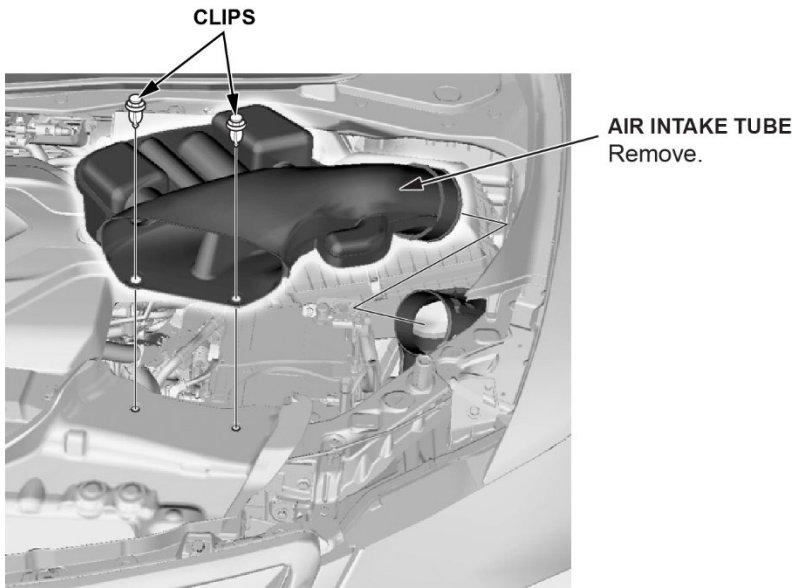

5. Disconnect the 12-volt battery.

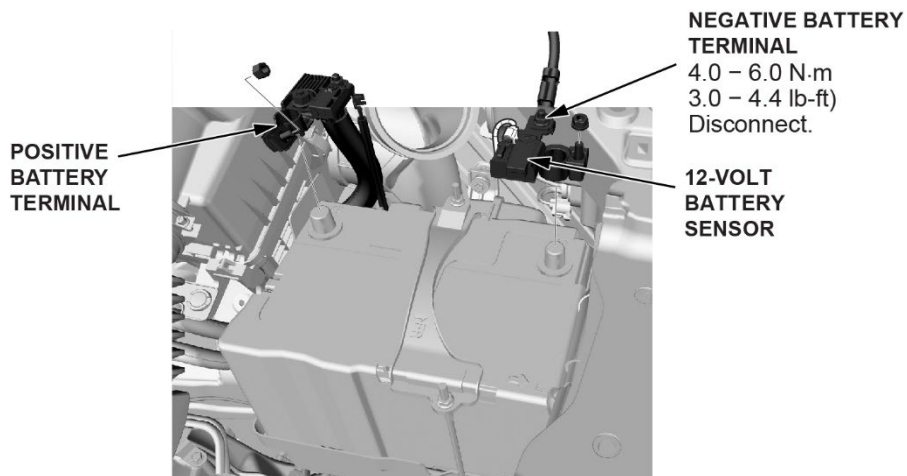

6. Remove the oil dipstick.

7. Set **cylinder #1** to top dead center (TDC). Align the pointer on the front upper cover with the No. 1 Piston TDC mark on the front camshaft pulley.

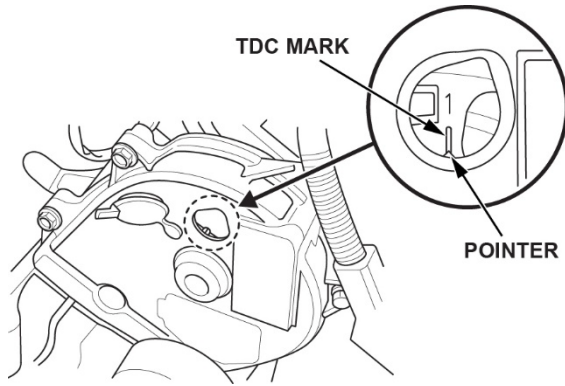

8. Disconnect and remove the coil packs.

FRONT

CONNECTOR

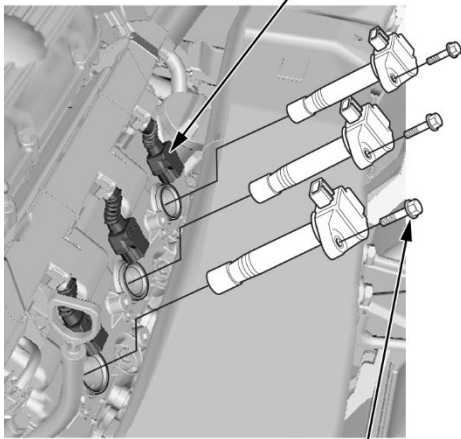

BOLTS
12 N.m
(9 lb-ft)

REAR

CONNECTOR

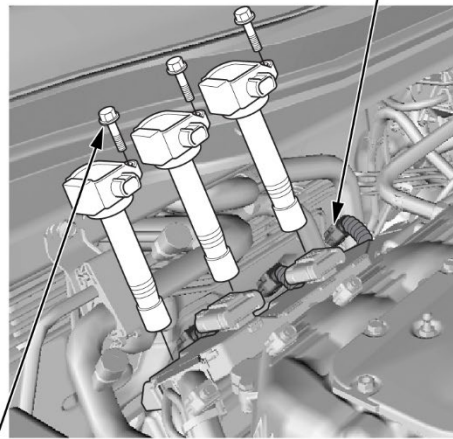

BOLTS
12 N.m
(9 lb-ft)

9. Remove the spark plugs.

FRONT

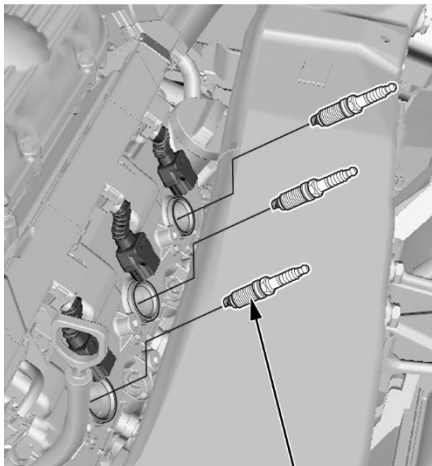

SPARK PLUGS
22 N.m (16 lb-ft)

REAR

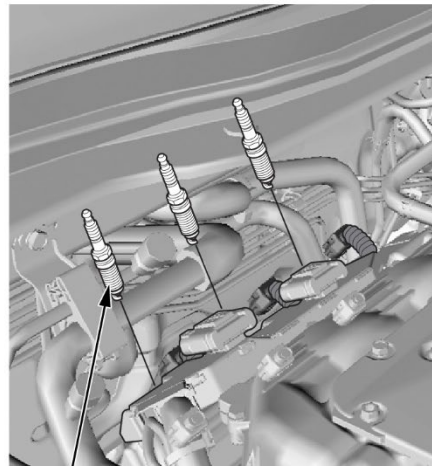

SPARK PLUGS
22 N.m (16 lb-ft)

10. Install the piston stoppers in **cylinders 2,3,4, & 6**.

NOTE: Make sure the stopper is clean, and hand tighten only.



Piston Stoppers
in cylinder #2 and #4.

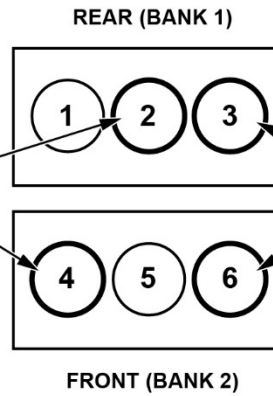

Piston Stoppers
in cylinder #3 and #6.

PISTON STOPPER
P/N 07AAB-5G0200



11. Raise the vehicle.

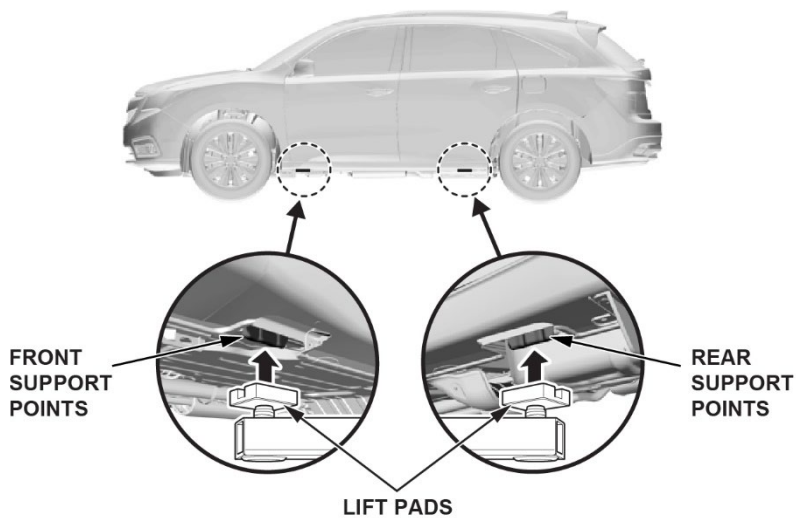

12. Remove the passenger side front wheel.

13. Pull back the passenger fender liner to gain access to the crankshaft pulley (the crankshaft pulley should be visible).

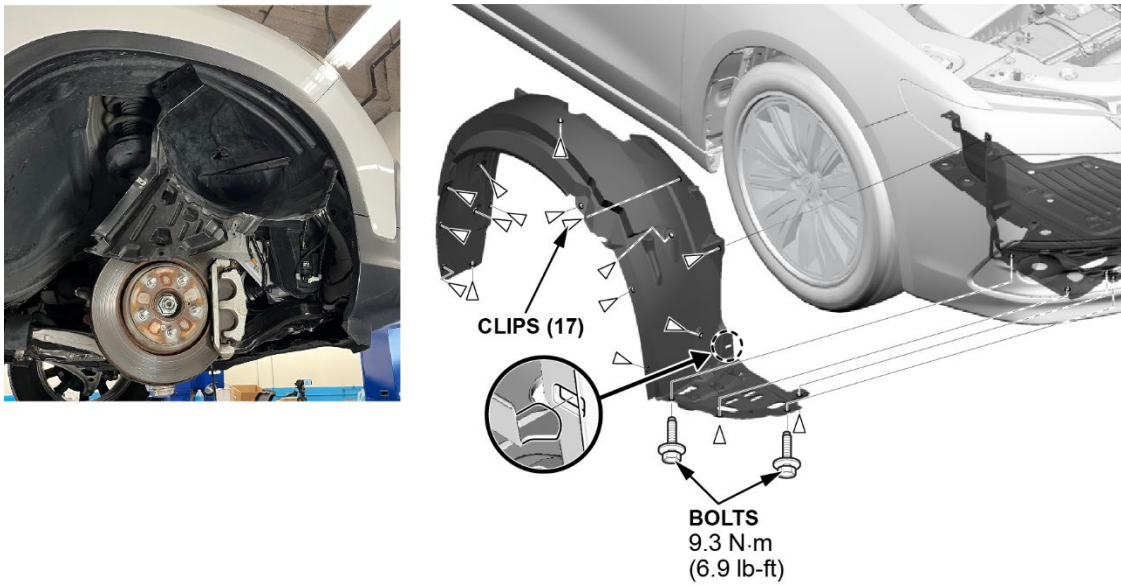

14. Drain the engine oil.

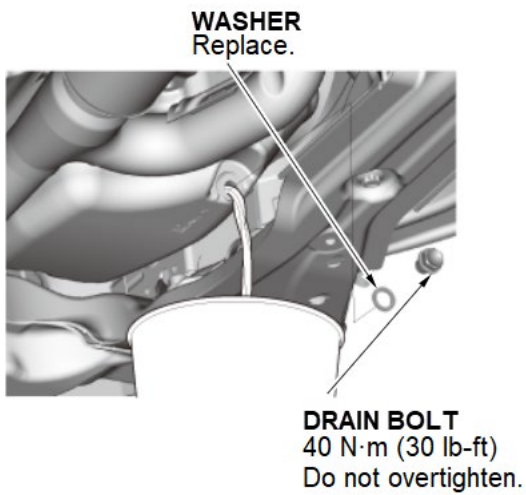

15. Remove the splash shield.

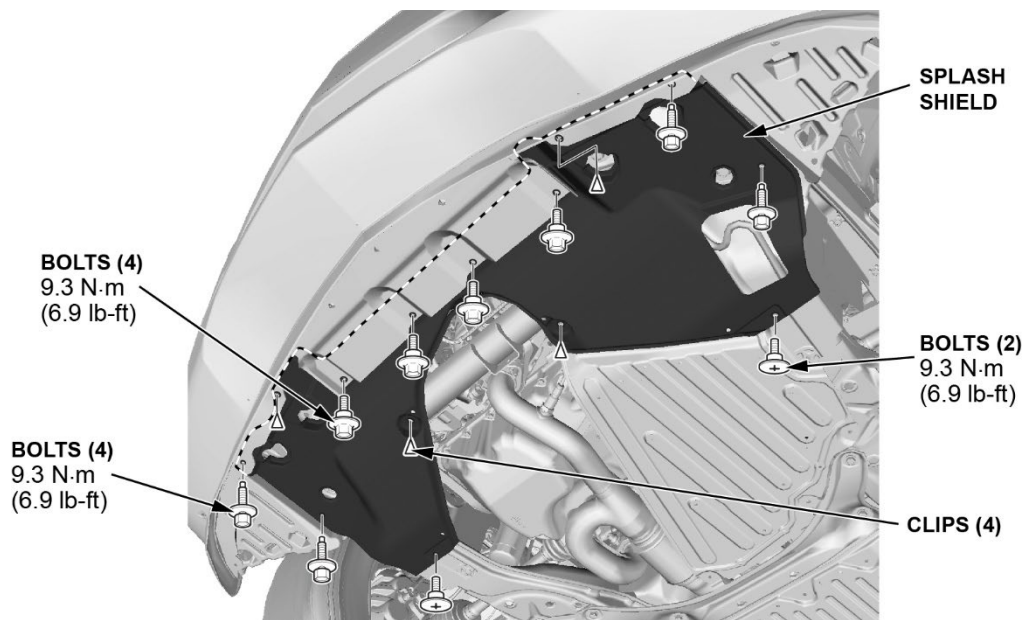

16. Remove the engine undercover.

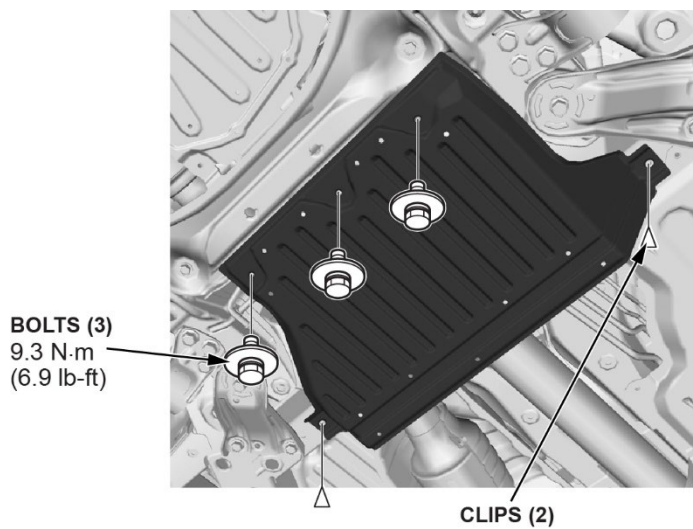

17. Remove the transmission undercover.

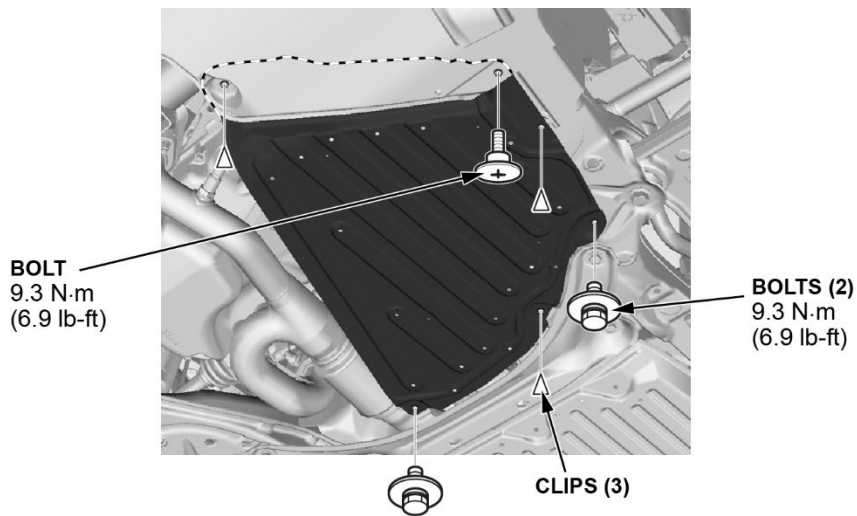

18. With **cylinder 1** at TDC, mark the crankshaft pulley with a vertical line at the 6 o'clock position.

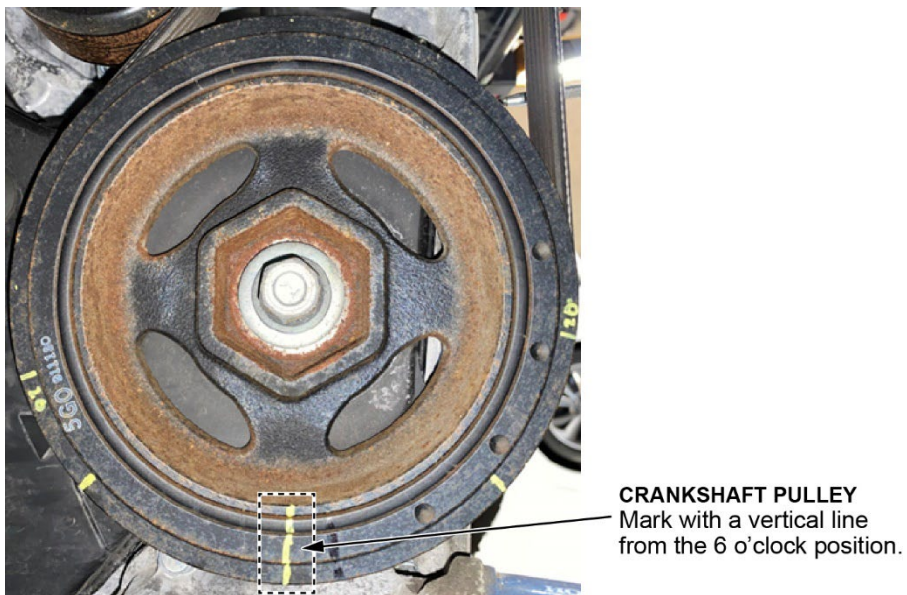

19. Attach the crank angle gauge to the crankshaft balancer pulley with **position #1** on the crank angle gauge aligned at the 6 o'clock position.

Click here to view video:

▶ PLAY VIDEO

NOTE: The back of the gauge is magnetic and will hold onto the pulley.



**CRANK ANGLE GAUGE
P/N 07AAJ-5G0A100**

20. Attach a large, commercially available zip tie to the subframe below the crankshaft pulley. The zip tie will be a **reference indicator** for a correct crank angle gauge position.

- Make sure it is pointing up at the 6 o'clock position on the pulley.
- The zip tie should extend roughly **8" to 12"** over the subframe.



ZIP TIE
Attach a zip tie to the frame
and line up as shown.

21. Unplug the bank 2 oxygen sensor, HO2S.

NOTE: Exhaust may be HOT.

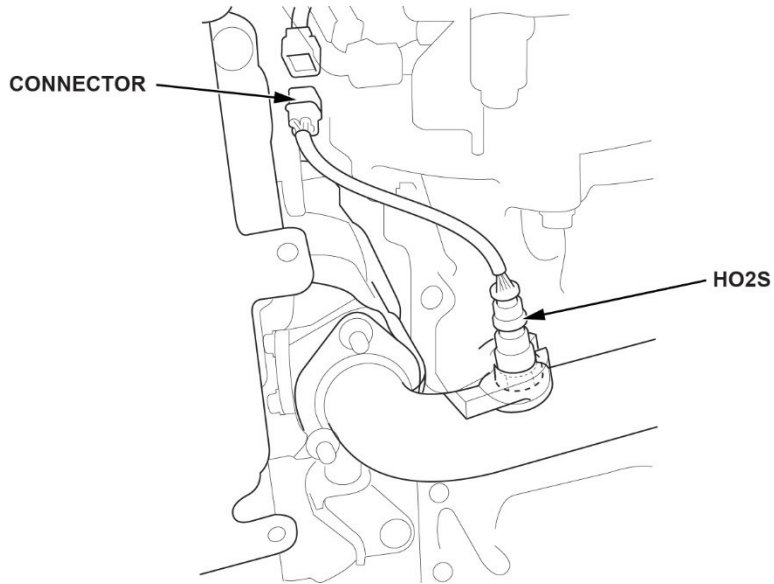

22. Remove the subframe stiffener plate.

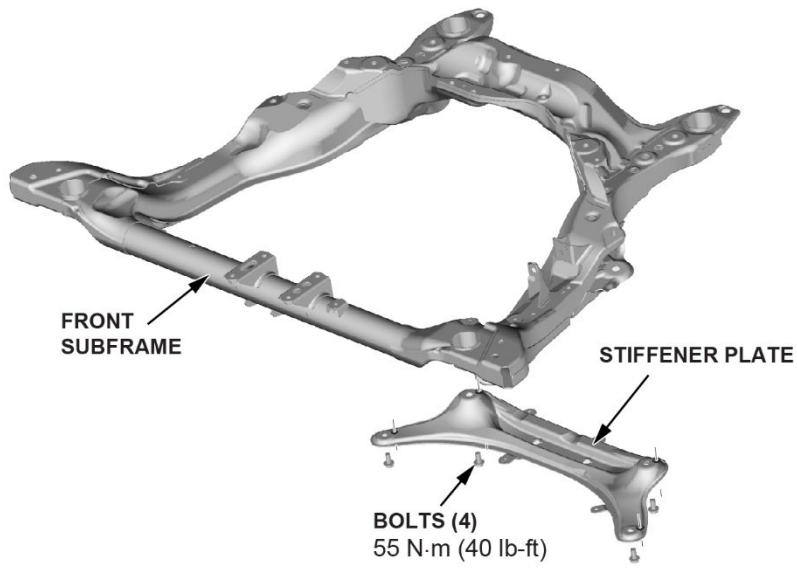

23. Remove the under-floor TWC (A-pipe).

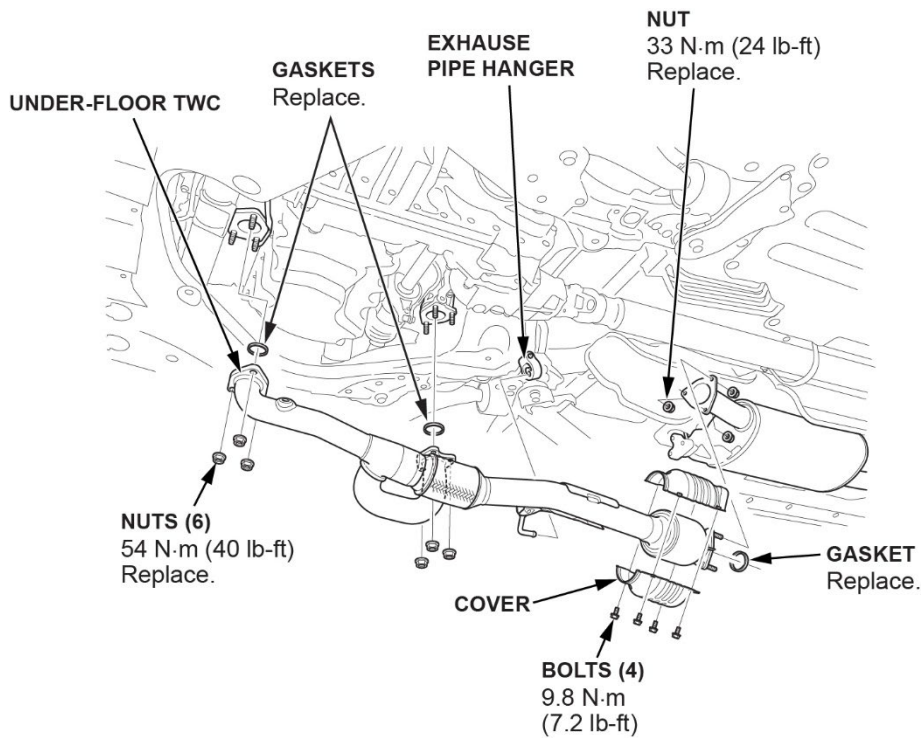

24. Remove the CKP sensor cover, then disconnect the CKP sensor.

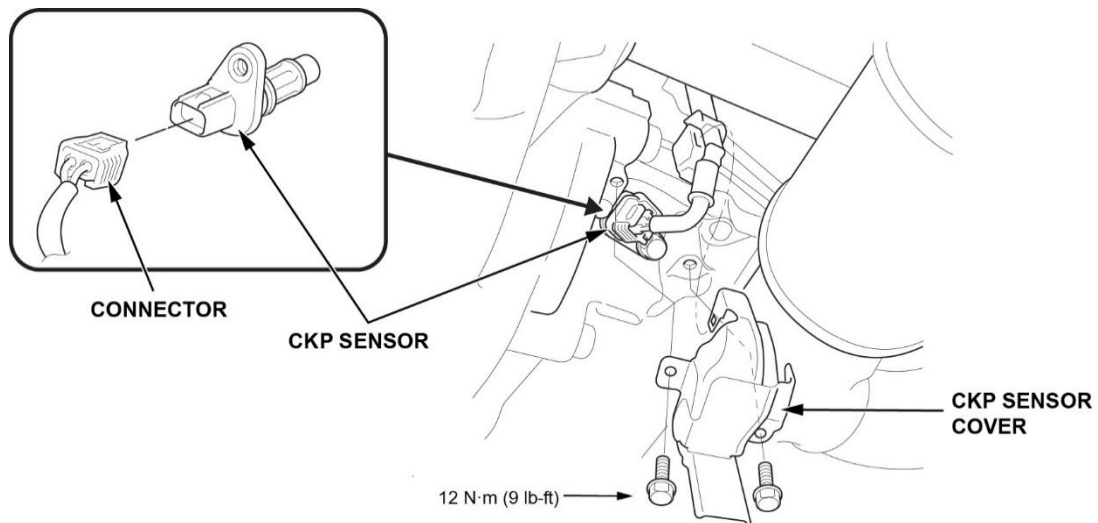

25. Remove the torque converter cover and the four lower transmission mounting bolts.

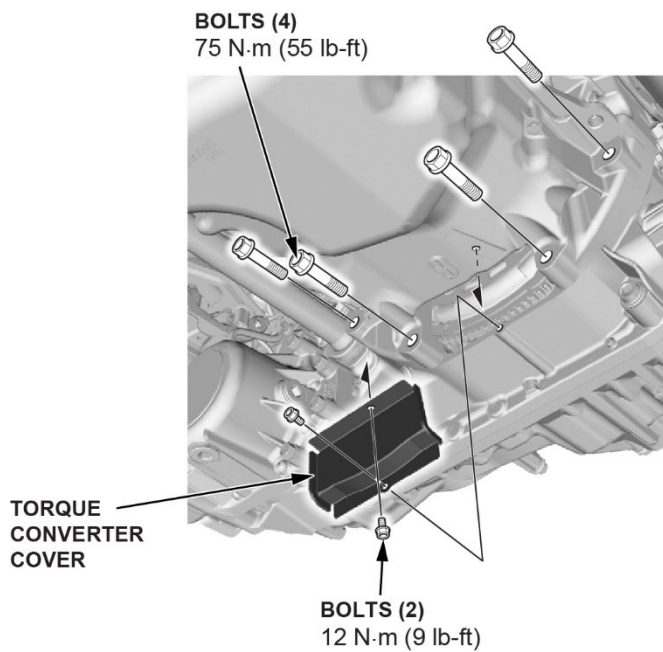

26. Remove the engine oil pan.

⚠ CAUTION

Hot engine oil may continue to drip from the engine which can cause burns or eye damage. Wear proper protective equipment and eyewear to avoid injury.

NOTE:

- Remove the bolts securing the oil pan.
- Use a flat blade screwdriver to separate the oil pan from the engine block.

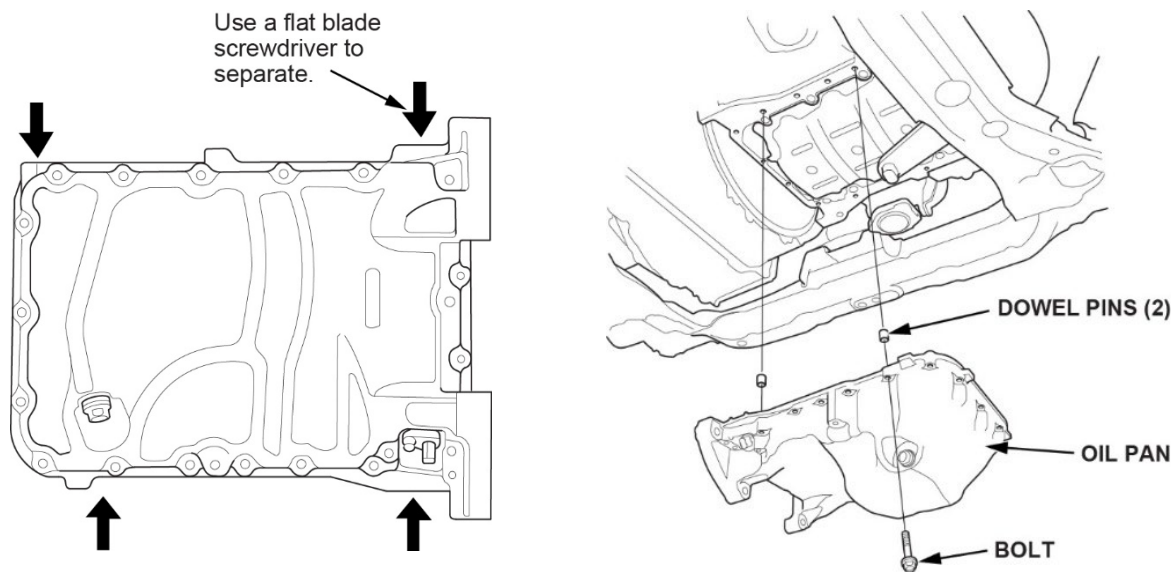

27. Remove the oil strainer and baffle plate.

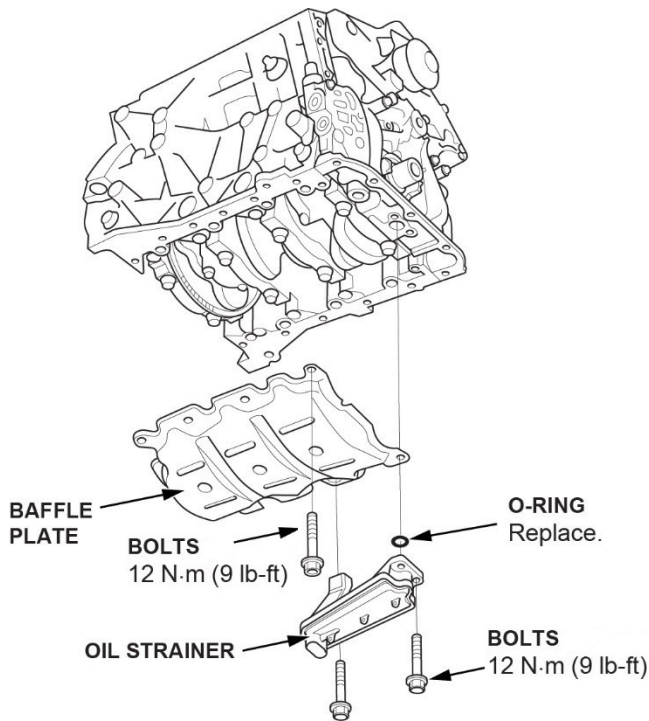

28. Clean and label each connecting rod cap with a paint marker (or otherwise suitable marking instrument) prior to removal. Make sure each rod cap has both the **cylinder #** and an **orientation arrow** pointing to the front of the vehicle.

NOTE:

- Do not confuse the existing marking on the side of the connecting rod and rod cap with the cylinder number. These are manufacturing marks referring to the size of the rod.
- Installing a rod cap incorrectly will result in engine knock and/or engine failure.

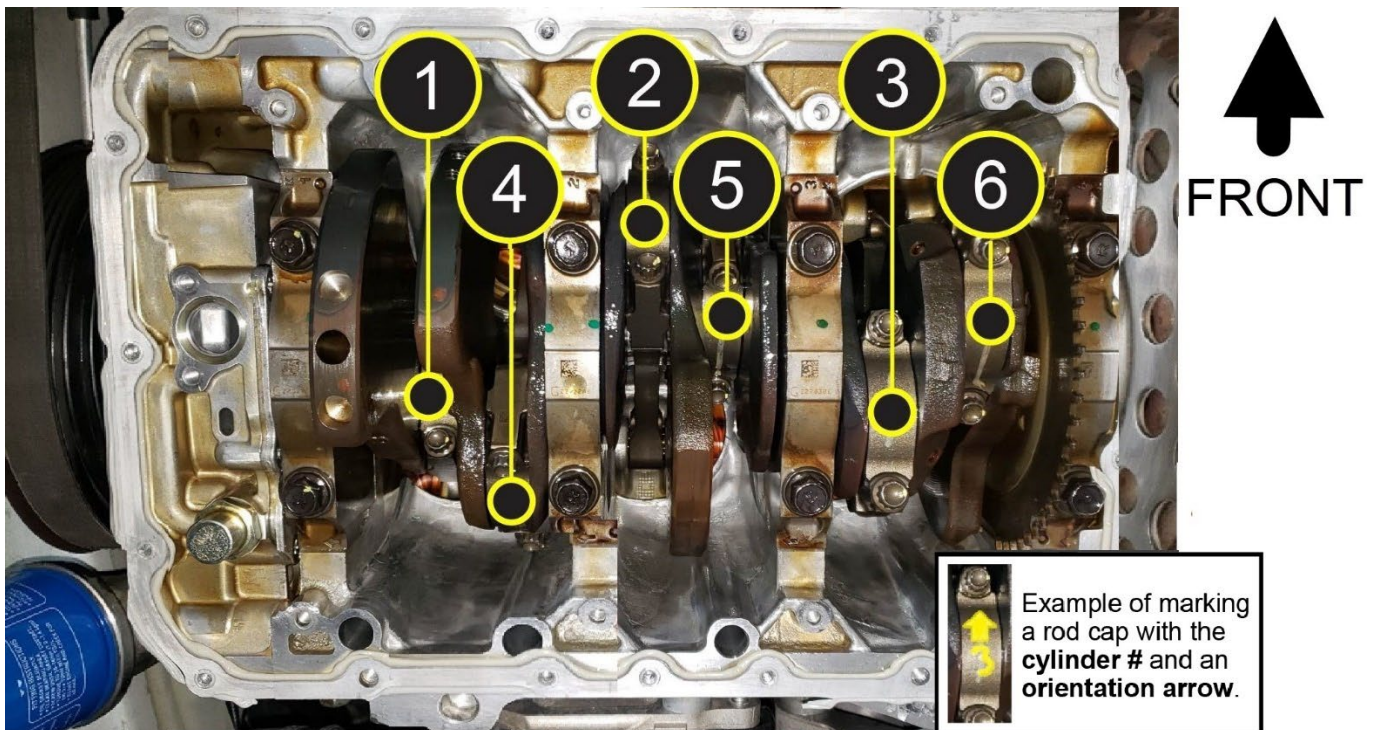

29. Make sure the Bearing Photo Box (Tool Number: 07AAK-5J2A200) and Inspection Trays are available for use.

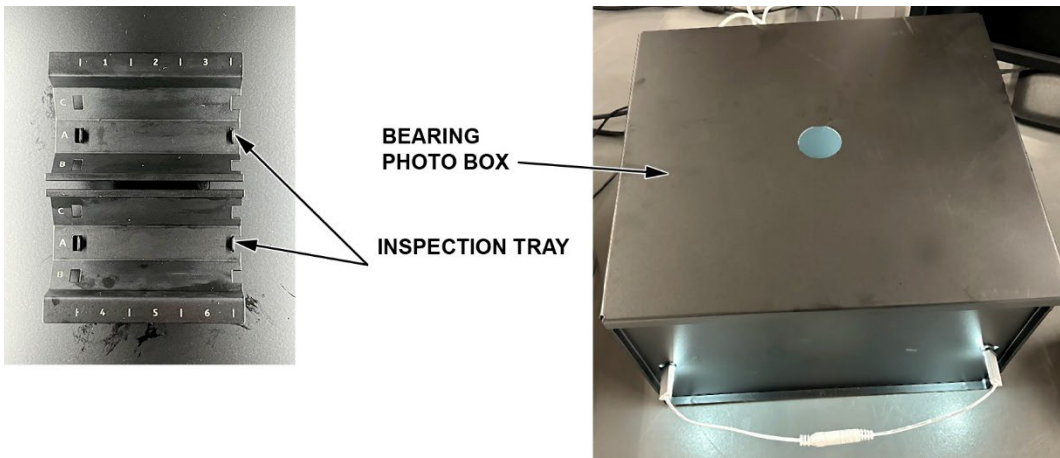

30. Make sure the cylinder 1 is at TDC, (position #1).



31. Remove the **connecting rod bearing cap and lower bearing for cylinders 1,3,5, and 6.**

Step/Crankshaft Position	Cylinder 1 Bearing Cap and Lower Bearings	Cylinder 3 Bearing Cap and Lower Bearings	Cylinder 5 Bearing Cap and Lower Bearings	Cylinder 6 Bearing Cap and Lower Bearings
#1/At TDC	Remove	Remove	Remove	Remove

Click here to view video:



NOTE:

- Follow the removal of the connecting rod bearing steps precisely to prevent damage to the crankshaft journal and connecting rods.
- The next steps involve manually moving the piston/rod assemblies while disconnected from the crankshaft. Moving the piston/rod assembly too far in either direction can damage the piston and/or oil jet.
- Thoroughly clean the bearings with a clean shop towel after removal. There should be no oil residue remaining. **Do not use solvents.**

32. Place the removed lower bearings from **cylinders 1,3,5, and 6** into the inspection tray.

NOTE:

- Thoroughly clean the bearings with a clean shop towel prior to placing the bearing in the inspection tray. No oil should be present. **Do not use any solvents.**
- **Place** the removed bearings into the inspection tray at the correct position. For example, the **cylinder 1 bearings** should be in the **#1 slot** in the **tray**. **Upper and lower bearing arrangement in the tray does not matter.**

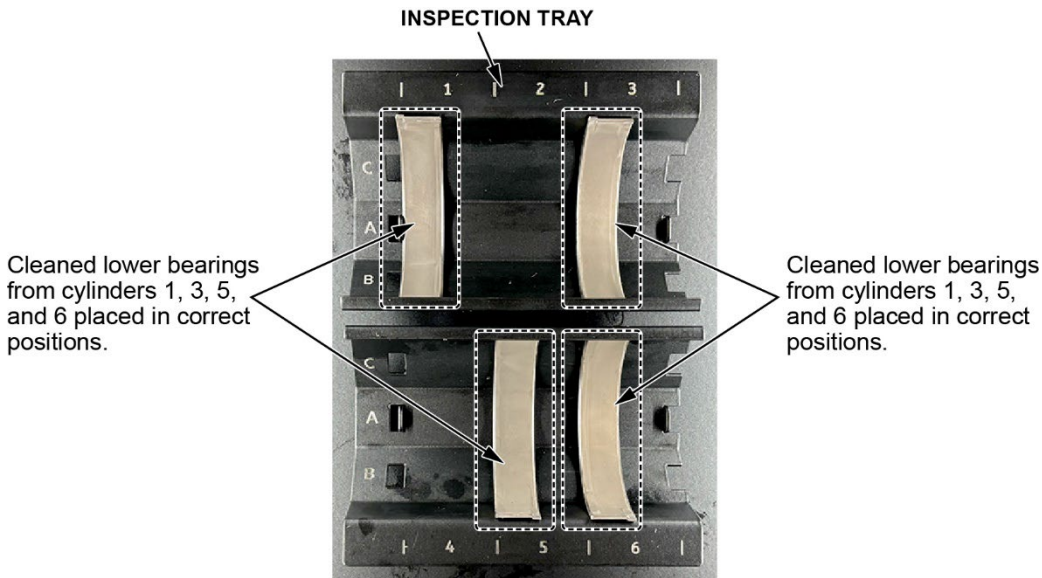

33. Rotate the crankshaft clockwise to the **#2 position** (TDC +45°).



Rotate the crank clockwise to the #2 position.

34. Remove the **cylinder 2** connecting rod bearing cap and lower bearing.

Step/Crankshaft Position	Cylinder 2 Bearing Cap and Lower Bearings
#2/TDC +45°	Remove

NOTE:

- Follow the removal of the connecting rod bearing steps precisely to prevent damage to the crank journal and connecting rods.
- The next steps involve manually moving the piston/rod assemblies while disconnected from the crankshaft. Moving the piston/rod assembly too far in either direction can damage the piston and/or oil jet.
- Thoroughly clean the bearing with a clean shop towel after removal. No oil should be present. **Do not use any solvents.**

35. Place the removed lower bearing from **cylinder 2** into the inspection trays.

NOTE:

- Follow the removal of the connecting rod bearing steps precisely to prevent damage to the crank journal and connecting rods.
- Thoroughly clean the bearing with a clean shop towel prior to placing in the inspection tray. No oil should be present. **Do not use any solvents.**
- **Place** the removed bearings into the inspection tray at the correct position. For example, the **cylinder 1 bearings** should be in the **#1 slot** in the **tray**. **Upper and lower bearing arrangement in the tray does not matter.**

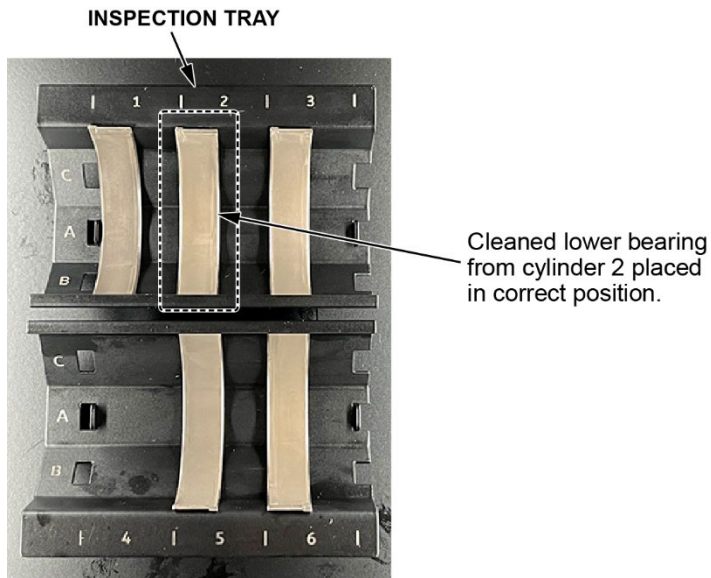

36. Remove the **cylinder 2** upper connecting rod bearing.

Step/Crankshaft Position	Cylinder 2 Upper Bearing
#2/TDC +45°	Remove

NOTE:

- Follow the removal of the connecting rod steps precisely to prevent damage to the crank journal and connecting rods.
- The next steps involve manually moving the piston/rod assemblies while disconnected from the crankshaft. Moving the piston/rod assembly too far in either direction can damage the piston and/or oil jet.
- Thoroughly clean the bearing with a clean shop towel after removal. No oil should be present. **Do not use any solvents.**
- Use the rod holder tool as needed, hand tighten only.

Click here to view video:

[▶ PLAY VIDEO](#)

M8 ROD HOLDER
P/N 07AAB-5G0A100



EXAMPLE OF USING THE M8 ROD HOLDER TOOL

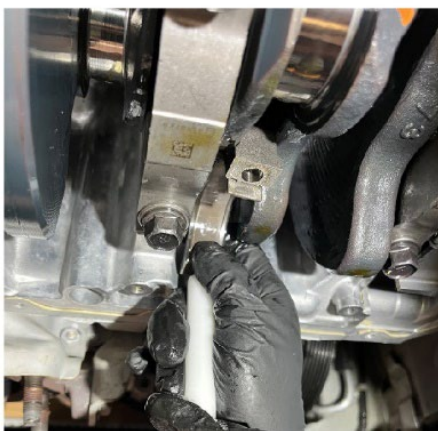

1. Thread the M8 rod holder tool into the connecting rod bolt hole.
2. Carefully push the connecting rod up until the connecting rod clears the crankshaft journal.
3. Swing the connecting rod to the side, then pull down just enough to gain access to the upper bearing.
4. Remove the upper bearing by sliding it to the side until it releases from the connecting rod.
5. Using the M8 rod holder tool, carefully push the connecting rod back up until it contacts the piston stopper.
6. Remove the M8 rod holder tool.
7. Thoroughly clean the bearing with a clean shop towel to remove all oil residue. **Do not use any solvents.**

37. Place the removed **upper bearing** from **cylinder 2** into the inspection tray.

NOTE:

- Thoroughly clean the bearing with a clean shop towel prior to placing in the inspection tray. No oil should be present. **Do not use any solvents.**
- **Place** the removed bearings into the inspection tray at the correct position. For example, the **cylinder 1 bearings** should be in the **#1 slot** in the **tray**. **Upper and lower bearing** arrangement in the tray **does not matter**.

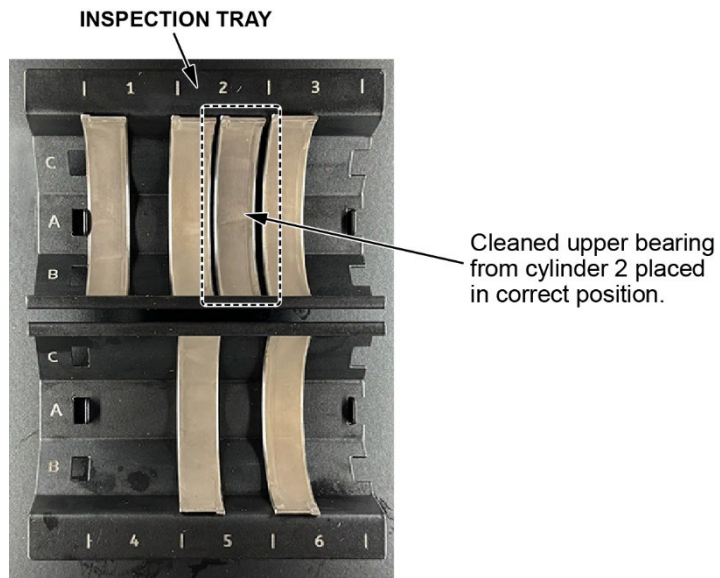

38. Rotate the crankshaft counterclockwise to the **#3 position** (TDC -45°).

Rotate the crank counterclockwise to the #3 position.



39. Remove the **cylinder 4** connecting rod bearing cap and lower bearing.

Step/Crankshaft Position	Cylinder 4 Rod Cap and Lower Bearing
#3/TDC -45°	Remove

NOTE:

- Follow the removal of the connecting rod steps precisely to prevent damage to the crank journal and connecting rods.
- The next steps involve manually moving the piston/rod assemblies while disconnected from the crankshaft. Moving the piston/rod assembly too far in either direction can damage the piston and/or oil jet.
- Thoroughly clean the bearing with a clean shop towel after removal. No oil should be present. **Do not use any solvents.**

40. Place the removed **lower bearing** from **cylinder 4** into the inspection tray.

NOTE:

- Thoroughly clean the bearing with a clean shop towel prior to placing in the inspection tray. No oil should be present. **Do not use any solvents.**
- **Place** the removed bearings into the inspection tray at the correct position. For example, the **cylinder 1 bearings** should be in the **#1 slot** in the **tray**. **Upper and lower bearing** arrangement in the tray **does not matter**.



41. Remove the **cylinder 3 and cylinder 4 upper connecting rod bearings.**

NOTE:

- Follow the removal of the connecting rod bearings precisely to prevent damage to the crank journal and connecting rods.
- The next steps involve manually moving the piston/rod assemblies while disconnected from the crankshaft. Moving the piston/rod assembly too far in either direction can damage the piston and/or oil jet.
- Thoroughly clean the bearing with a clean shop towel after removal. No oil should be present. **Do not use any solvents.**
- Use the M8 as needed, hand tighten only!

Step/Crankshaft Position	Cylinder 3 Upper Bearing	Cylinder 4 Upper Bearing
#3/TDC -45°	Remove	Remove

EXAMPLE OF USING THE M8 ROD HOLDER:



1. Thread the rod holder into the connecting rod bolt hole.
2. Carefully push the connecting rod up until the connecting rod clears the crankshaft journal.
3. Swing the connecting rod to the side, then pull down just enough to gain access to the upper bearing.
4. Remove the upper bearing by sliding it to the side until it releases from the connecting rod.
5. Using the rod holder, carefully push the **cylinder 3** connecting rod back up until it clears the crankshaft journal.
NOTE: Leave **cylinder 4** connecting rod in the lower position, **do not** push back up.
6. Remove the rod holder.
7. Thoroughly clean the bearings with a clean shop towel to remove all oil residue. **Do not use any solvents.**

42. Place the removed **upper bearings** from **cylinder 3 and 4** into the inspection tray.

NOTE:

- Thoroughly clean the bearing with a clean shop towel prior to placing in the inspection tray. No oil should be present. **Do not use any solvents.**
- **Place** the removed bearings into the inspection tray at the correct position. For example, the **cylinder 1 bearings** should be in the **#1 slot** in the **tray**. **Upper and lower bearing** arrangement in the tray **does not matter**.

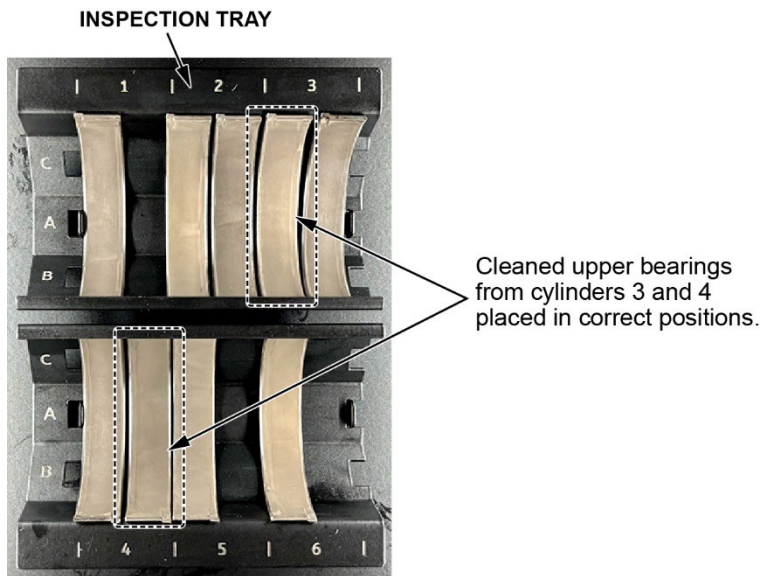

43. Rotate the crankshaft clockwise to the **#4 position** (TDC +90°).

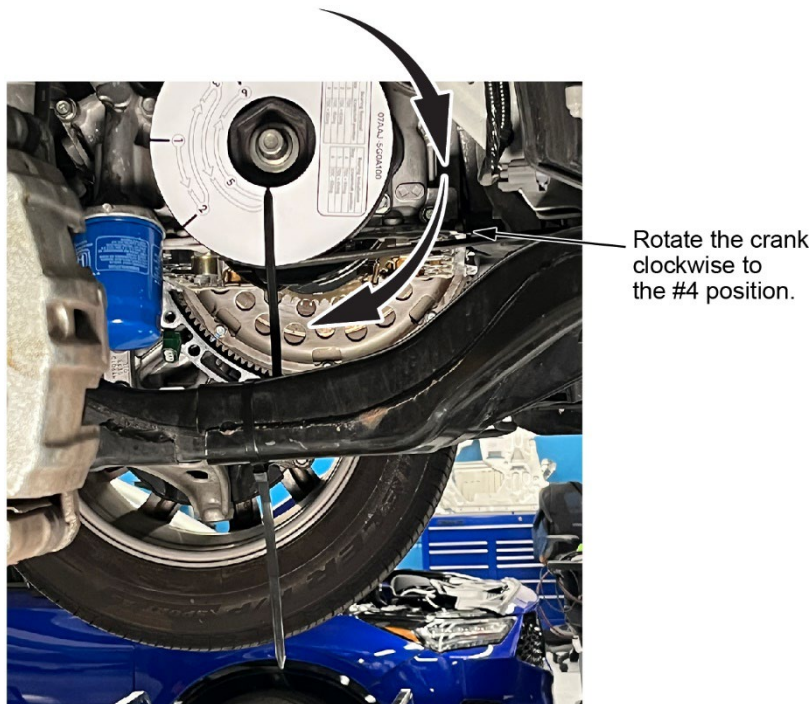

44. Remove the **upper bearing from cylinders 1, 5, and 6.**

Step/Crankshaft Position	Cylinder 1 Upper Bearing	Cylinder 5 Upper Bearing	Cylinder 6 Upper Bearing
#4/TDC +90°	Remove	Remove	Remove

NOTE:

- Follow the removal of the connecting rod steps precisely to prevent damage to the crank journal and connecting rods.
 - The next steps involve manually moving the piston/rod assemblies while disconnected from the crankshaft. Moving the piston/rod assembly too far in either direction can damage the piston and/or oil jet.
 - Thoroughly clean the bearing with a clean shop towel after removal. No oil should be present. **Do not use any solvents.**
 - Use the rod holder tool as needed, hand tighten only.
1. Thread the M8 rod holder tool into the connecting rod bolt hole.
 2. Carefully push the connecting rod up until the connecting rod clears the crankshaft journal.
 3. Swing the connecting rod to the side, then pull down just enough to gain access to the upper bearing.
 4. Remove the upper bearing by sliding it to the side until it releases from the connecting rod.
 5. Using the M8 rod holder tool, carefully push the connecting rod back up until it contacts the piston stopper.
 6. Remove the M8 rod holder tool.
 7. Thoroughly clean the bearings with a clean shop towel to remove all oil residue. **Do not use any solvents.**

45. Place the removed **upper bearings** from **cylinders 1, 5, and 6** into the inspection tray.

NOTE:

- Thoroughly clean the bearing with a clean shop towel prior to placing in the inspection tray. No oil should be present. **Do not use any solvents.**
- **Place** the removed bearings into the inspection tray at the correct position. For example, the **cylinder 1 bearings** should be in the **#1 slot** in the **tray**. **Upper and lower bearing** arrangement in the tray **does not matter**.

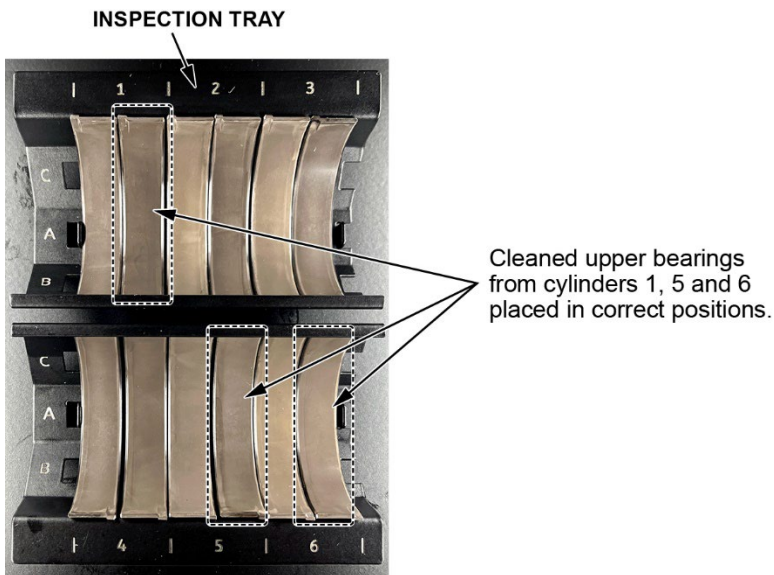

46. Make sure the bearings are fully seated and level with the edge of the inspection tray.

- The bearing's indexing tab should be lined up at the numbers.
- The flat edge of the bearing should be inside the lip.
- All bearings should be fully seated.

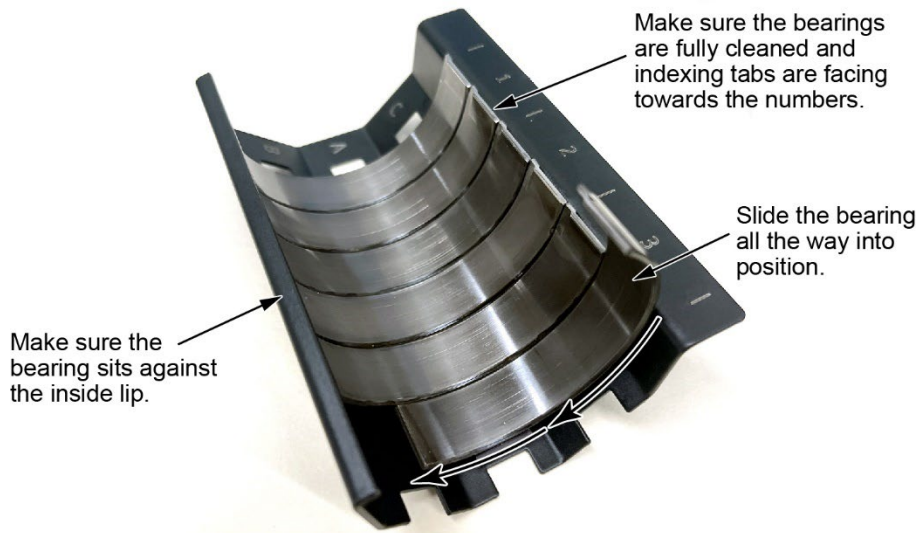

47. Remove the bearing photo box cover and place the bearing inspection trays in the bearing photo box.

NOTE: When taking photos make sure there are no objects in the bearing photo box, only the bearing trays with bearings.

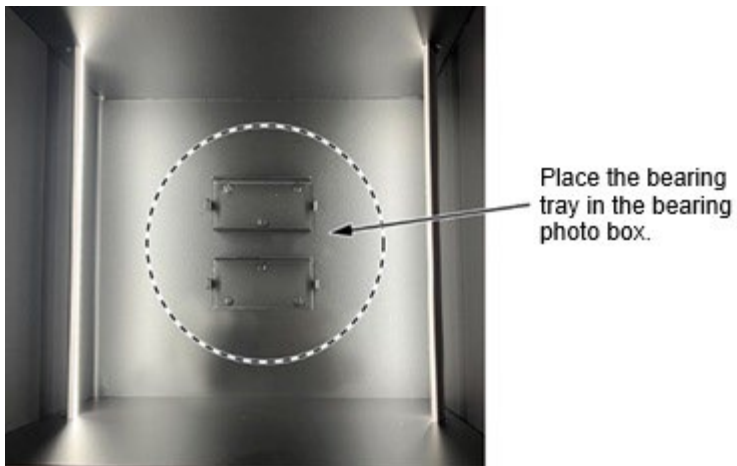

48. Confirm the following is ready on the bearing photo box:

1. Lights at the brightest setting.
NOTE: The lighting can be adjusted with a long hold on the button.
2. Both bearing trays in position A with non-numbered sides facing each other.
3. The O-rings are set on the lights to prevent an outside light source.

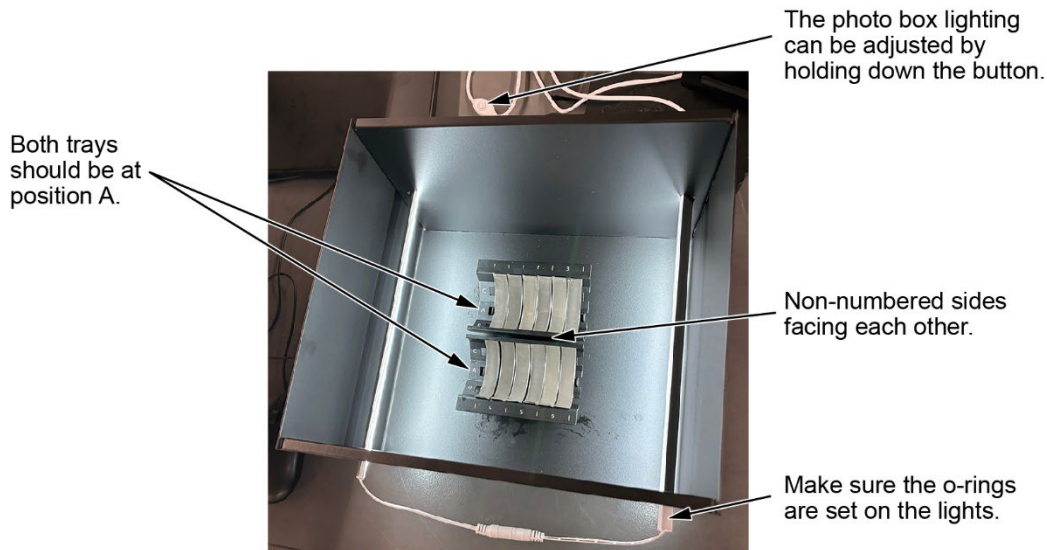

49. Using the BEARING INSPECTION application tool, follow the instructions to take bearing photos in positions A, B, and C. Follow the prompts when submitting the photos.

NOTE:

- For BEARING INSPECTION application instruction, refer to this Job Aid: [\(Click HERE\)](#)
- Technicians are now required to center-punch all 12 bearings to prevent reuse of the bearings. **DO NOT** center punch the bearing until instructed by the application tool. Submitting any photos with center-punches for Photos A, B and C **WILL BE REJECTED**.
- Use the camera tap focus for a clear image.
- Any unclear images will not be accepted.
- Follow the BEARING INSPECTION application prompts after photo submission.

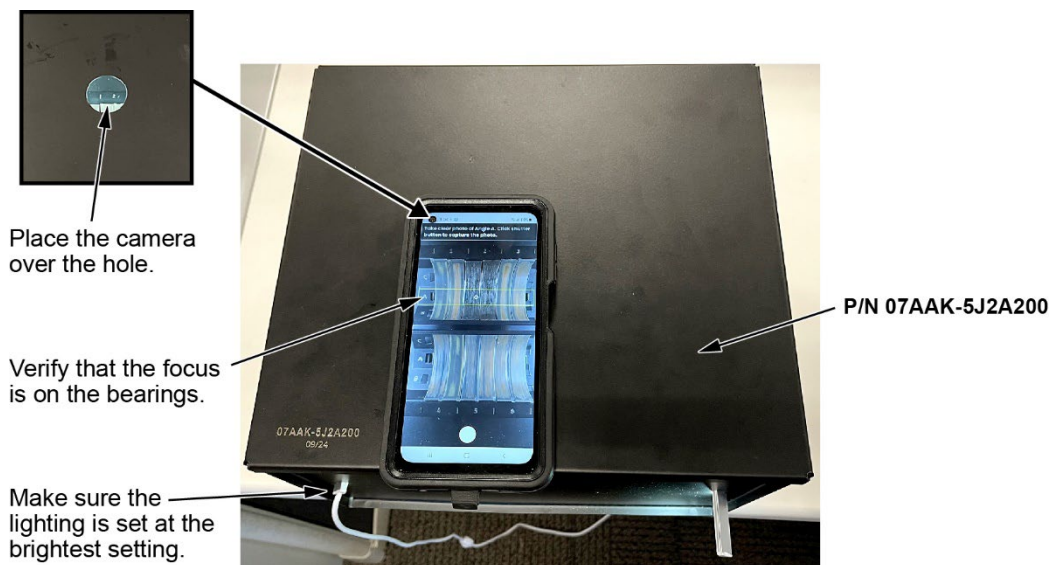

When taking the photos:

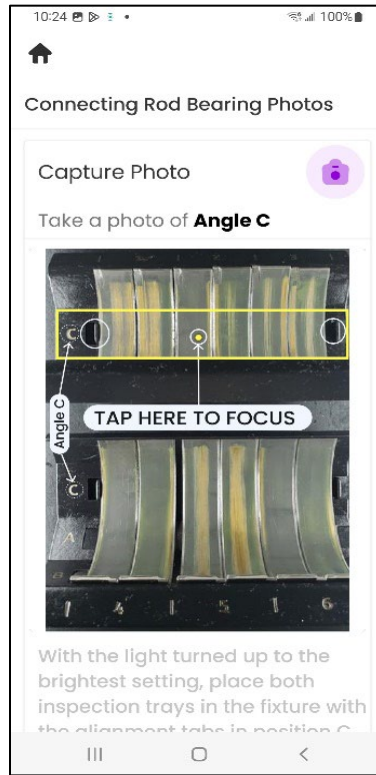
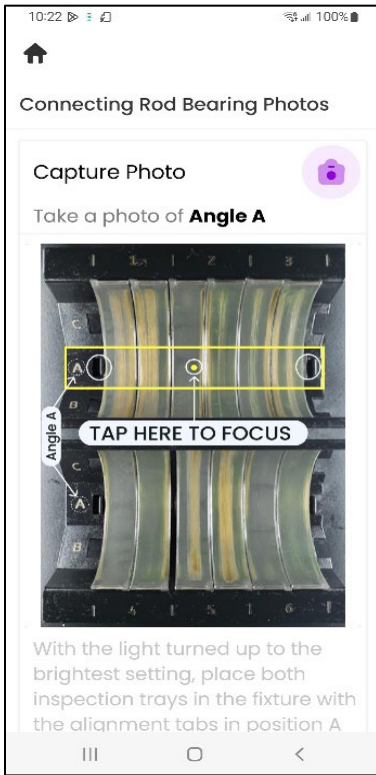

Centered punch bearings:

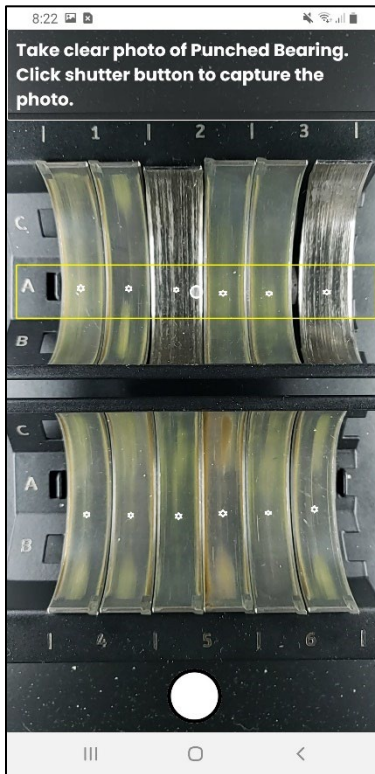

50. When the Bearing Inspection Inquiry Team completes the review and assigns a repair method, the following will occur:

1. The Bearing Inspection Recall Status screen will update with the specified repair.
2. If optional mobile numbers are included in the technician's contact information, a text message will be issued to advise the inspection is complete and refers the technician to the Bearing Inspection Repair Direction Sheet that was issued to the email addresses on file.
3. An email, which provides a link to the Bearing Inspection Repair Direction Sheet, is issued to all addresses on file.

The Repair Direction Sheet provides the Inspection and Repair Warranty Codes required to file the warranty claims. If Bearing Only or Crankshaft replacement is required, the Repair Direction Sheet provides the bearing sizes and graphics identifying the location in which they should be installed.

INSPECTION B

NOTE: DO NOT contact Tech Line for any inquiries about this safety recall. If instructed by the application tool, call the Bearing Inspection Inquiry Team at (800) 824-6632 (**Select Option #9**).

1. Turn the steering wheel all the way to the right.
2. Relieve the fuel pressure.

With the i-HDS:

1. Connect an interface tool to the data link connector (DLC) located under the driver's side of the dashboard and launch i-HDS.

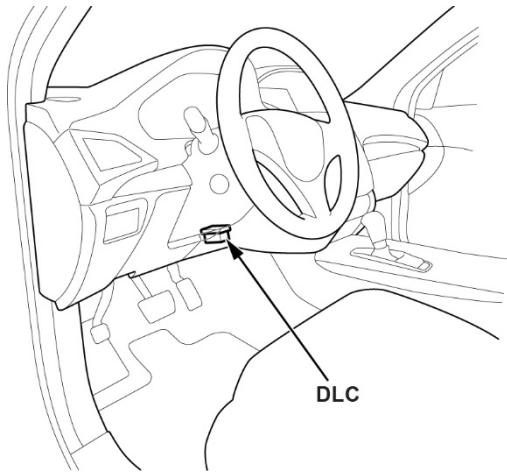

2. Turn the vehicle to ON.
3. Select the **PGM-FI** system on the i-HDS.
4. Select **FUEL PUMP OFF** from the **Inspection Menu** and follow the on-screen instructions.

Without the i-HDS:

1. Remove the PGM-FI main relay 2 from the under-dash fuse/relay box.
 2. Start the engine and let it idle until it stalls.
 3. Turn the vehicle to OFF.
 4. Install the PGM-FI main relay 2.
3. Remove the front bulkhead cover.

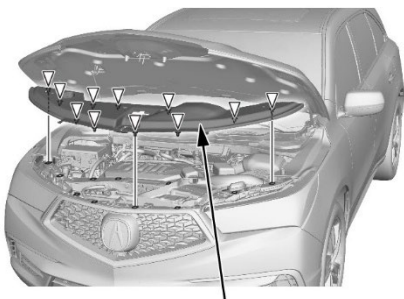

FRONT BULKHEAD COVER

4. Remove the air intake tube.

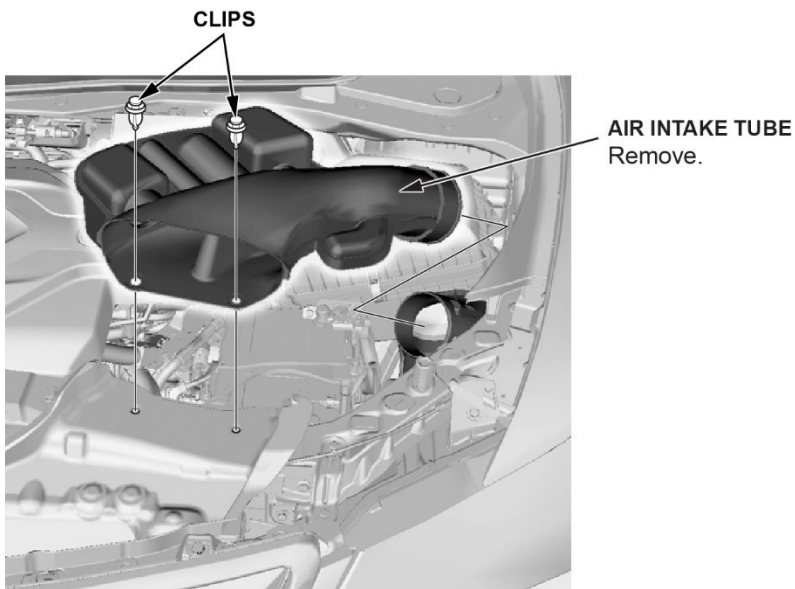

5. Disconnect the 12-volt battery.

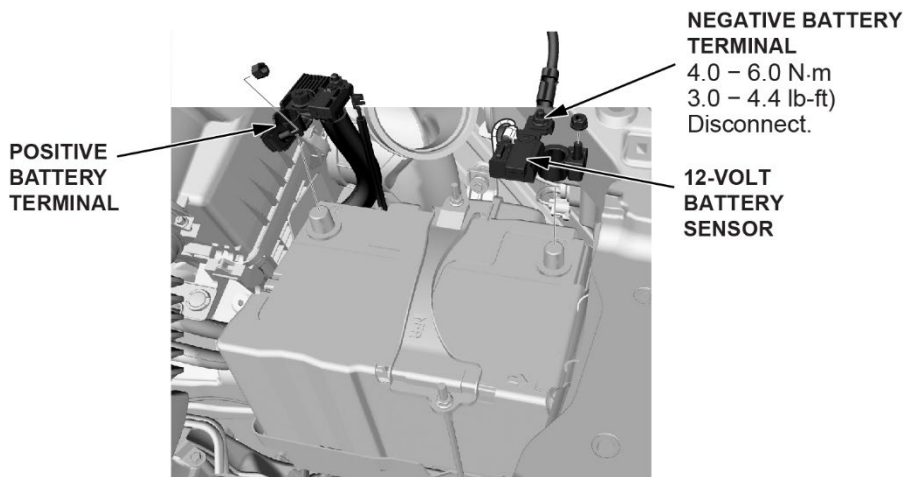

6. Remove the oil dipstick.
7. Set the crankshaft to TDC.

8. Disconnect and remove the coil packs.

FRONT

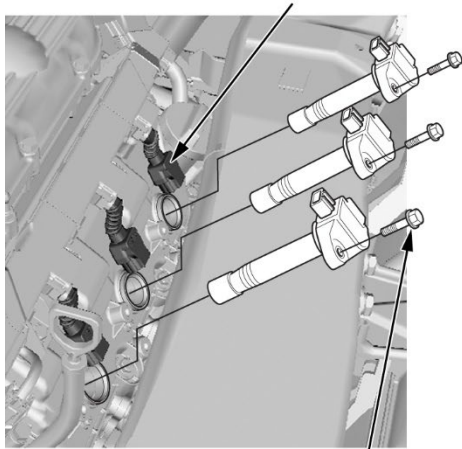

CONNECTOR

BOLTS
12 N·m
(9 lb-ft)

REAR

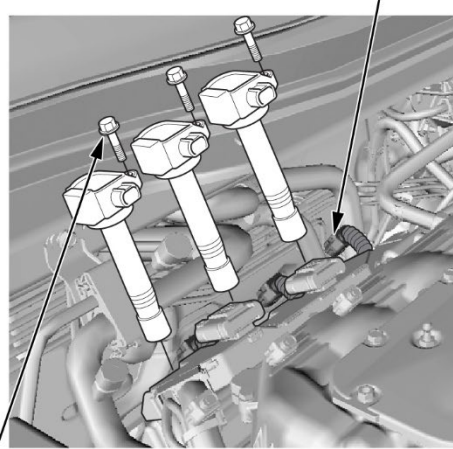

CONNECTOR

BOLTS
12 N·m
(9 lb-ft)

9. Remove the spark plugs.

FRONT

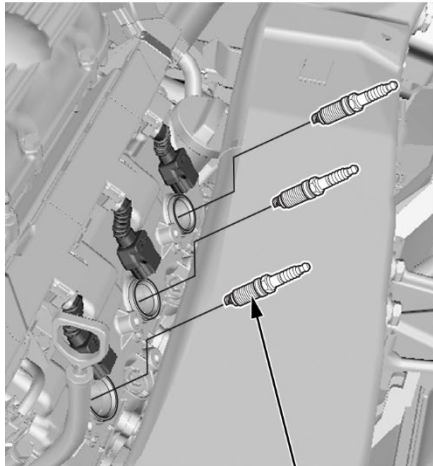

SPARK PLUGS
22 N·m (16 lb-ft)

REAR

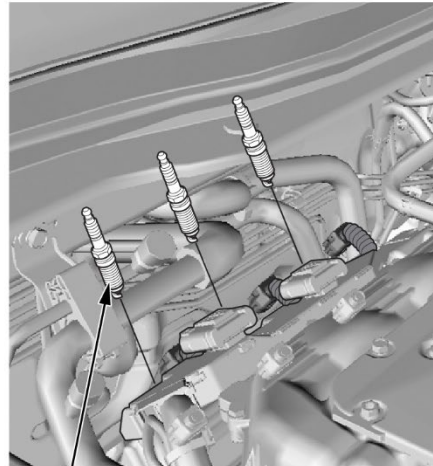

SPARK PLUGS
22 N·m (16 lb-ft)

10. Raise the vehicle.

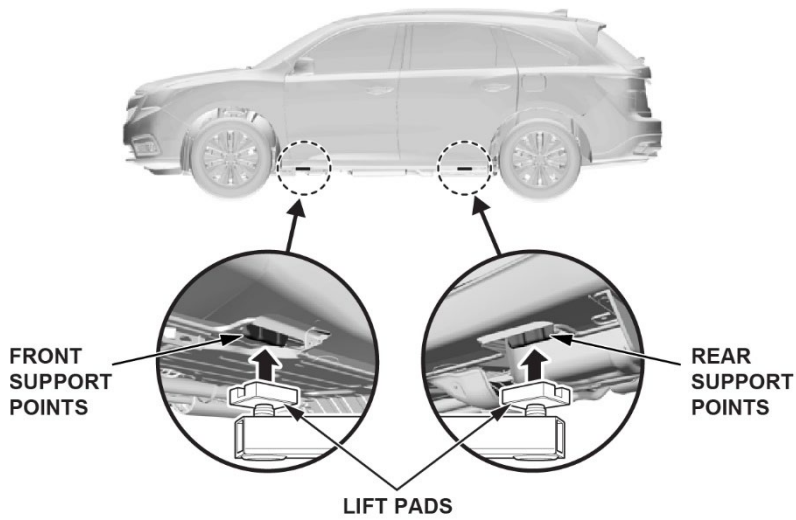

11. Remove the splash shield.

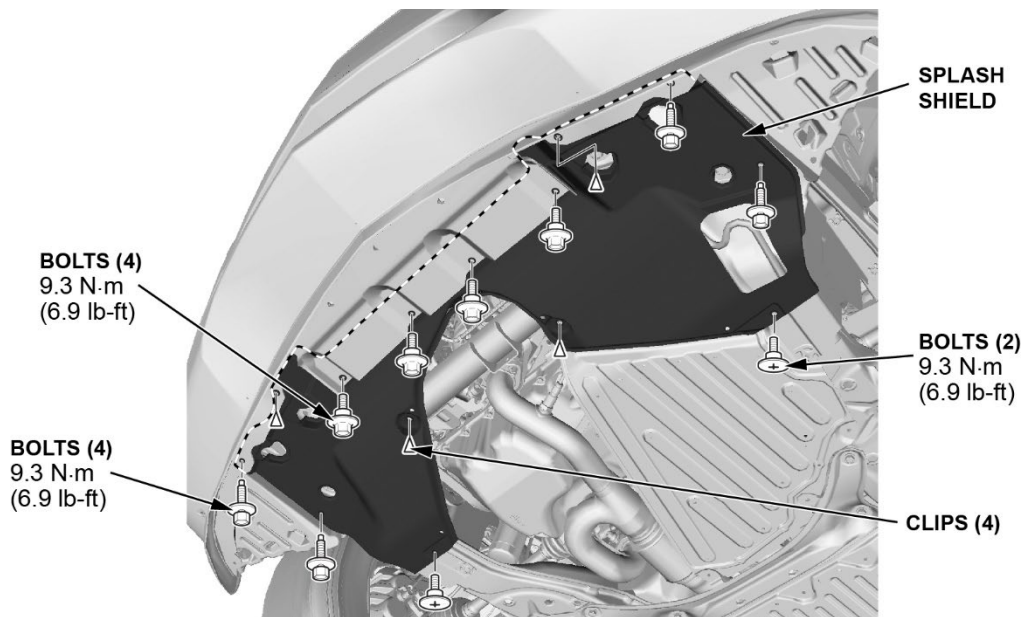

12. Remove the engine undercover.

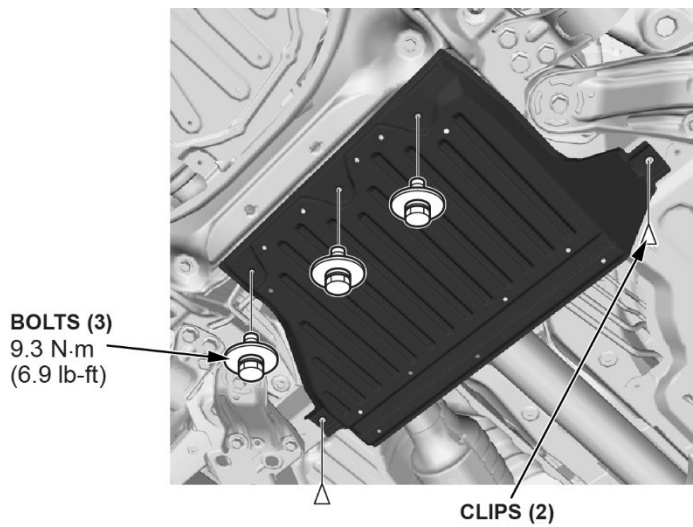

13. Remove the transmission undercover.

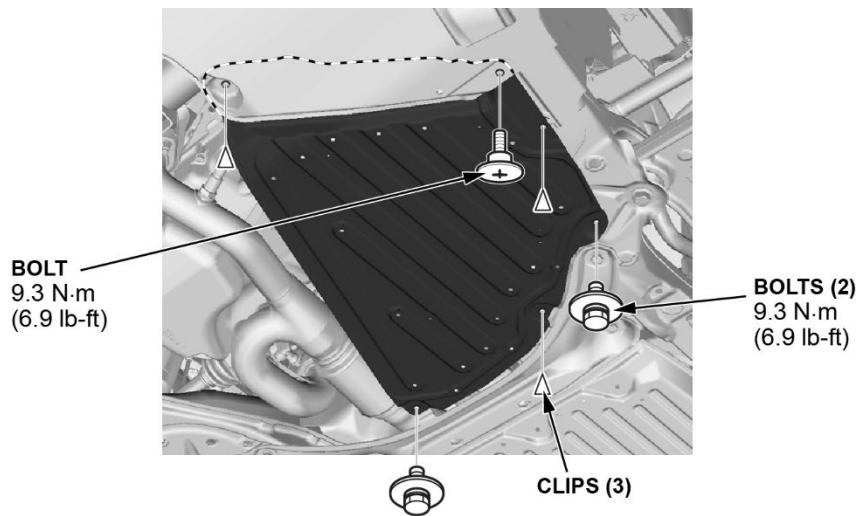

14. Remove the passenger side front wheel.

15. Remove the drive belt.

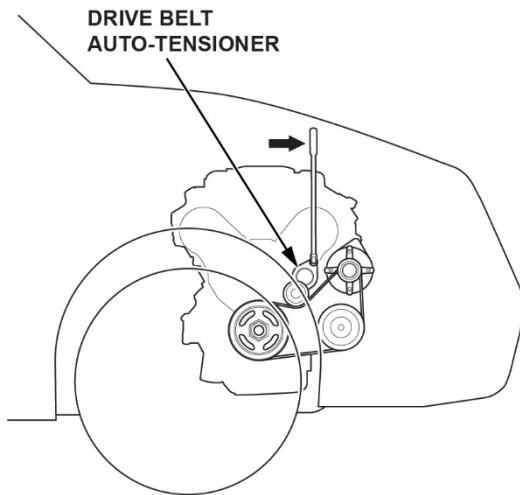

16. Separate the passenger's side tie rod ball joint.

1. Remove the cotter pin.
2. Remove the nut.
3. Disconnect the tie rod end ball joint from the knuckle using the ball joint thread protector and the ball joint remover.

NOTE: Be careful not to damage the ball joint boot when installing the ball joint remover.

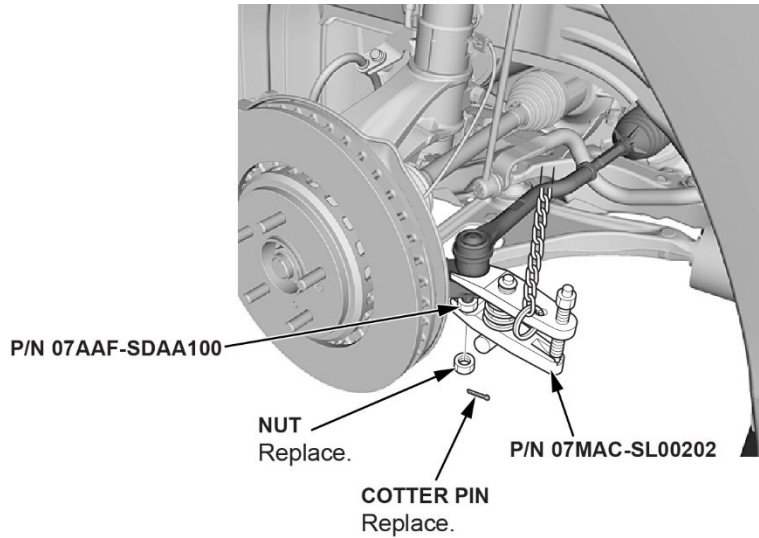

17. Separate the passenger's side lower knuckle ball joint.

1. Remove the lock pin.
2. Remove the castle nut.
3. Disconnect the lower arm ball joint from the knuckle using the ball joint thread protector and the ball joint remover.

NOTE: Be careful not to damage the ball joint boot when installing the ball joint remover.

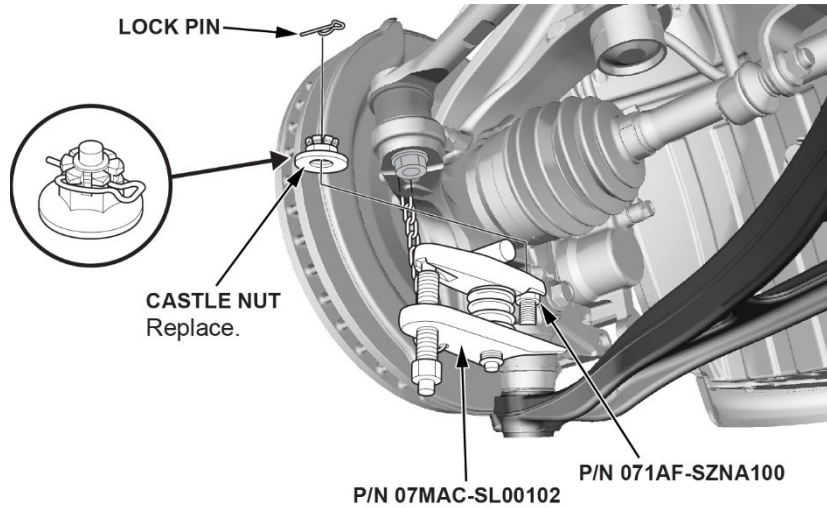

18. Remove the passenger's side driveshaft:

1. Remove the front spindle nut.
2. Pull the knuckle outward and separate the outboard joint from the front hub using a soft face hammer.

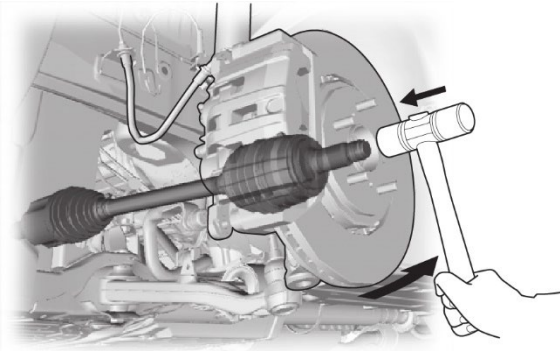

3. Drive the inboard joint off of the intermediate shaft using a drift punch and a hammer.

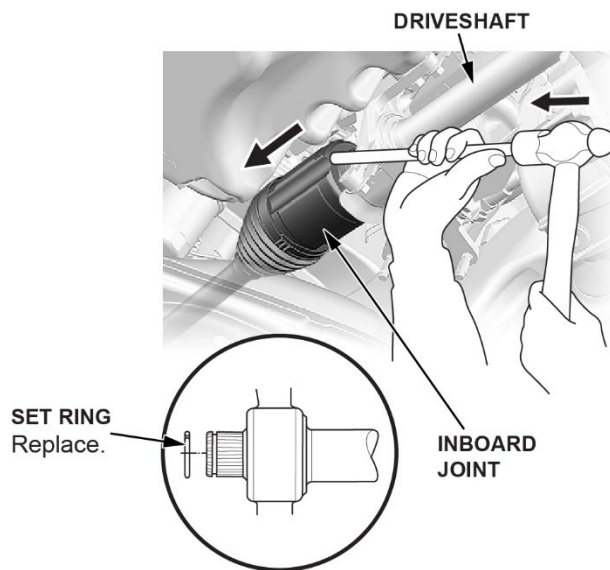

4. Remove the driveshaft as an assembly.
5. Remove and replace the set ring.

19. Remove the lower bolt of the bulkhead brace.

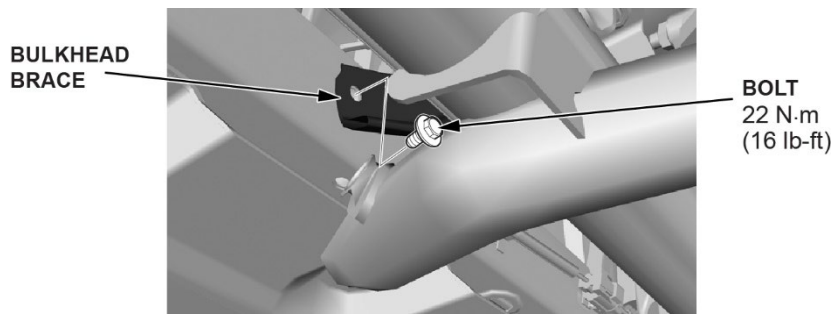

20. Pull back the passenger fender liner to gain access to the crankshaft pulley (the crank angle gauge should be visible).

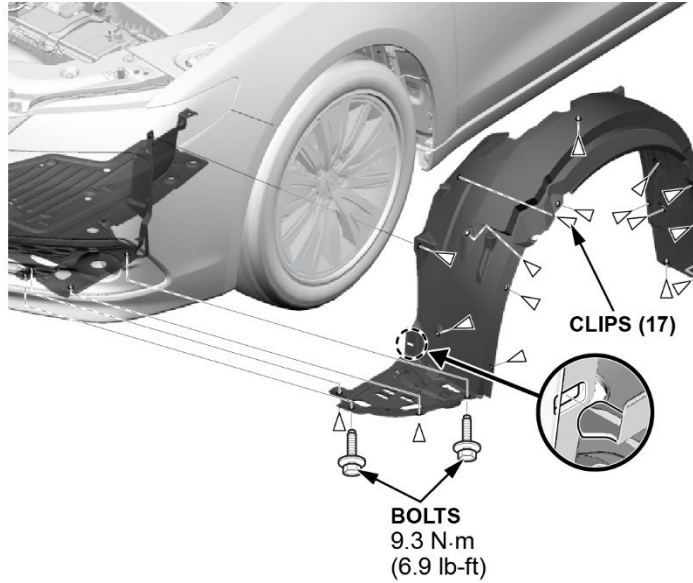

21. Drain the engine oil.

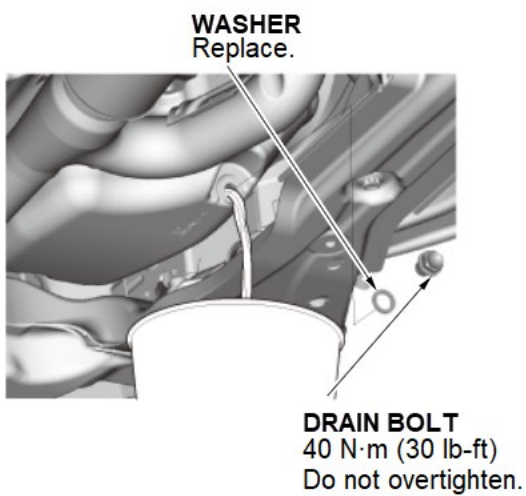

22. Unplug the bank 2 oxygen sensor.

NOTE: Exhaust may be HOT.

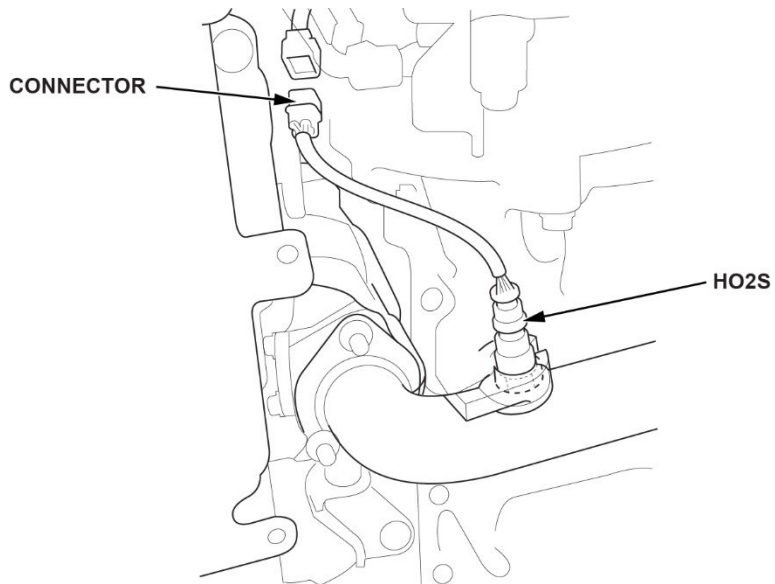

23. Remove the subframe stiffener plate.

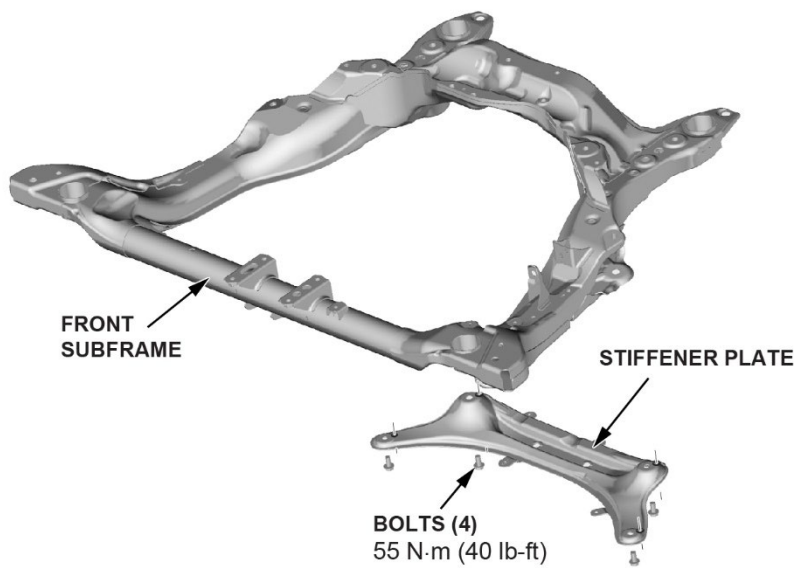

24. Remove the under-floor TWC (A-pipe).

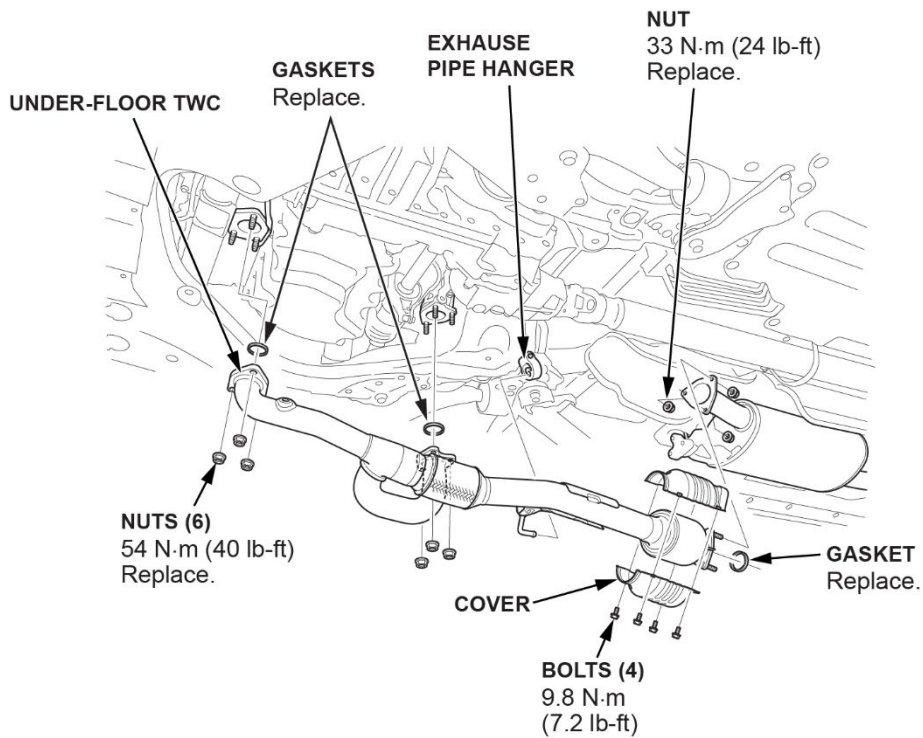

25. Remove the CKP sensor cover, then disconnect the CKP sensor.

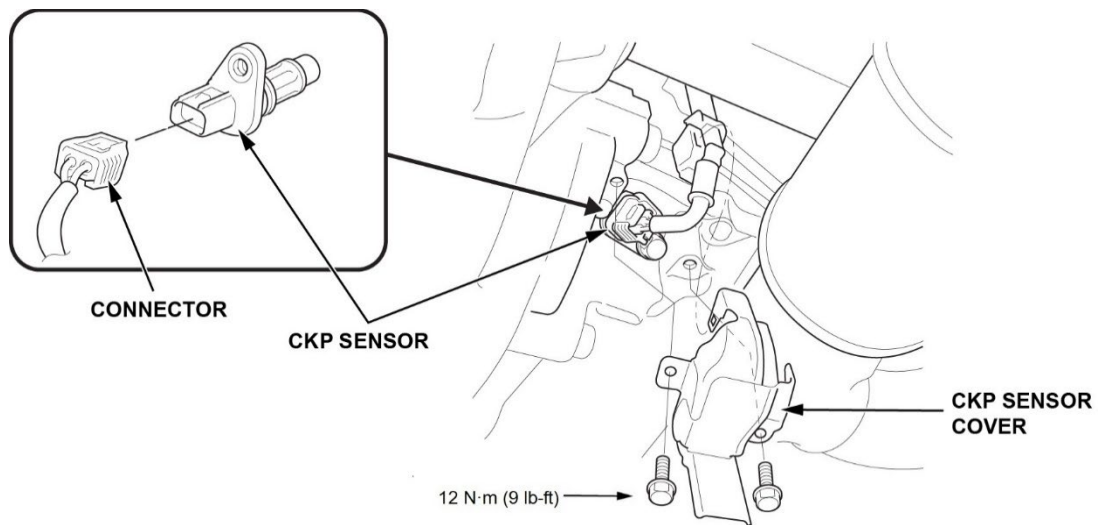

26. Remove the torque converter cover and the four lower transmission mounting bolts.

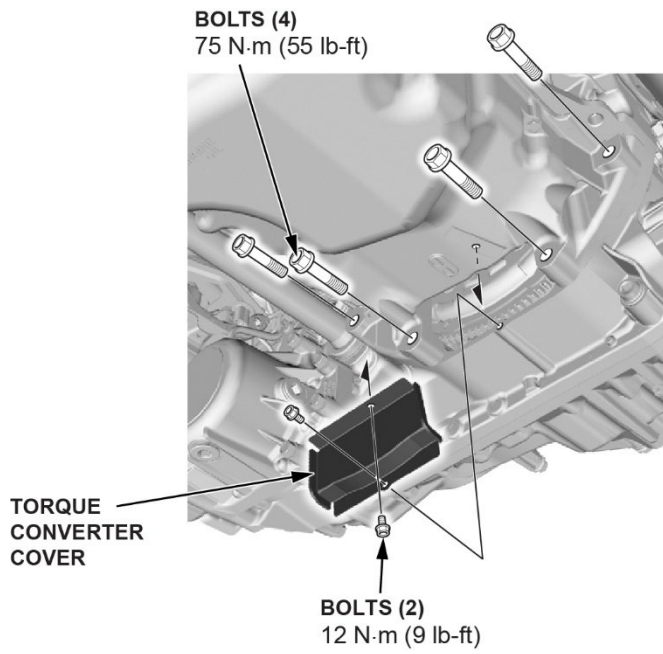

27. Lower the vehicle.

28. Remove the bulkhead.

14 – 16 MY SHOWN

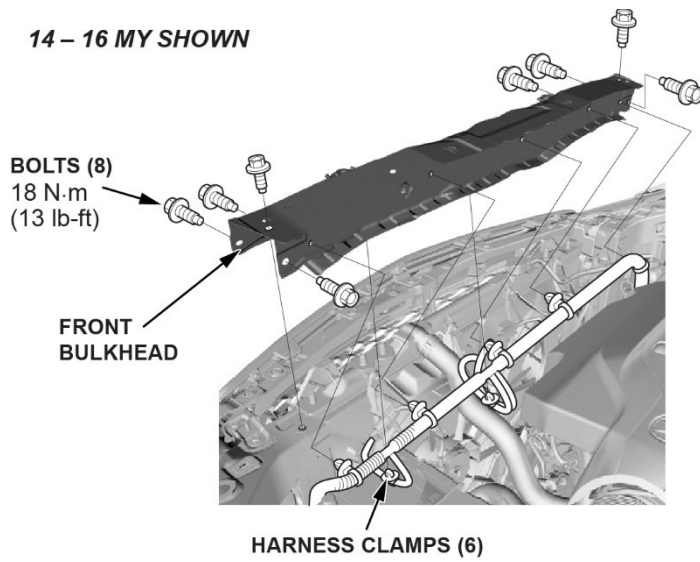

29. Remove the passenger's side bulkhead brace.

LOOKING DOWN FROM UNDER HOOD

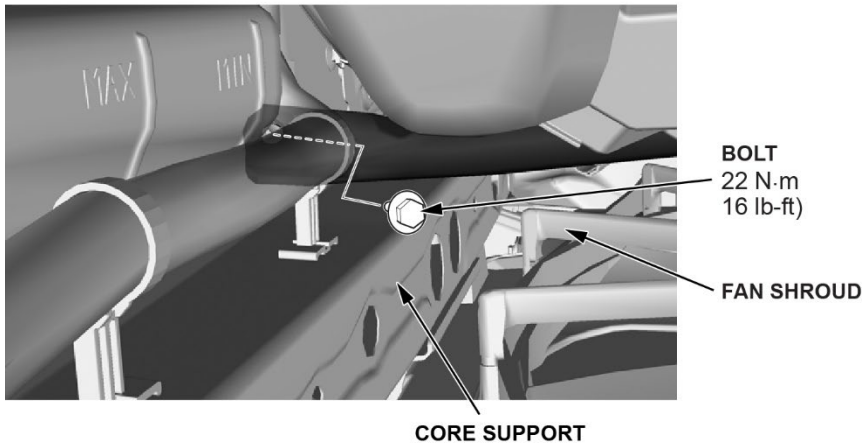

30. Disconnect and remove the condenser fan.

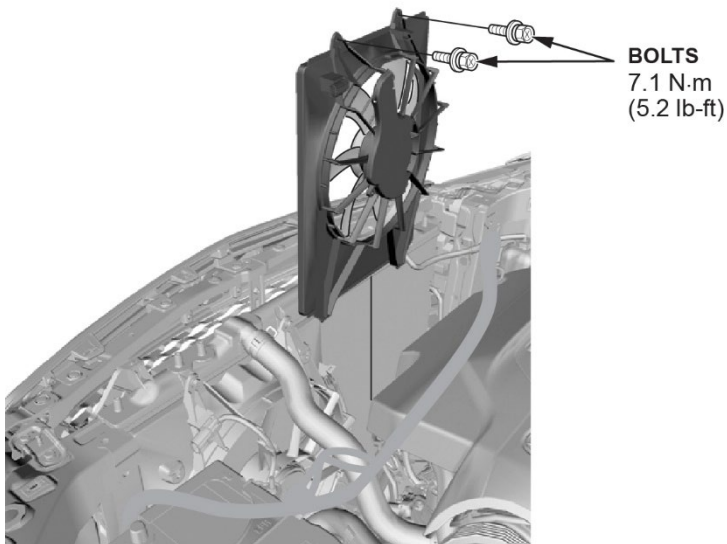

31. Remove the alternator.

1. Disconnect the positive alternator cable, the alternator connector, and the A/C compressor clutch connector.
2. Remove the harness clamp and bolt.

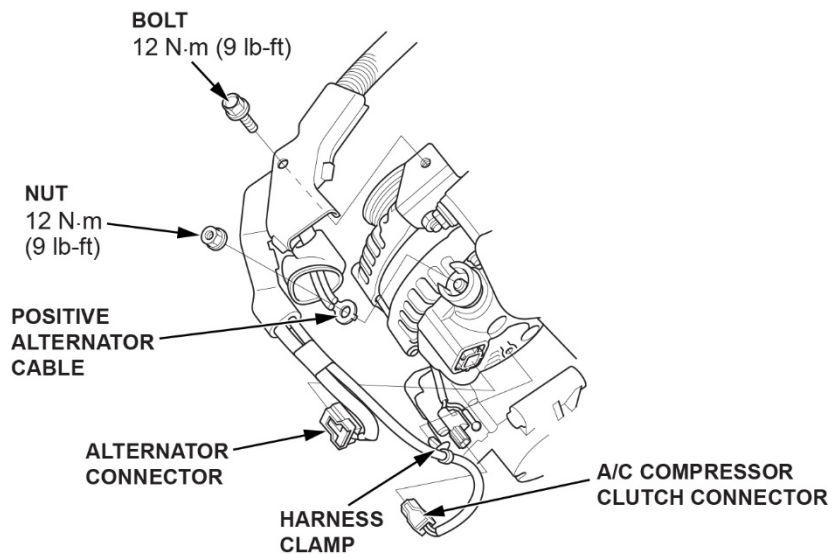

32. Remove the alternator

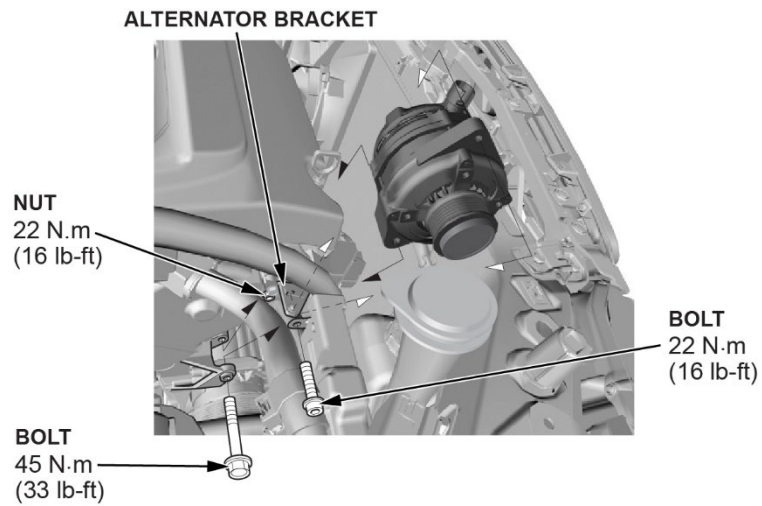

33. Install the radiator protector to protect the radiator.

NOTE:

- A suitable radiator shield could be as simple as a clean piece of cardboard.
- Make sure the shield covers the entire radiator surface that was exposed with the fan removed.

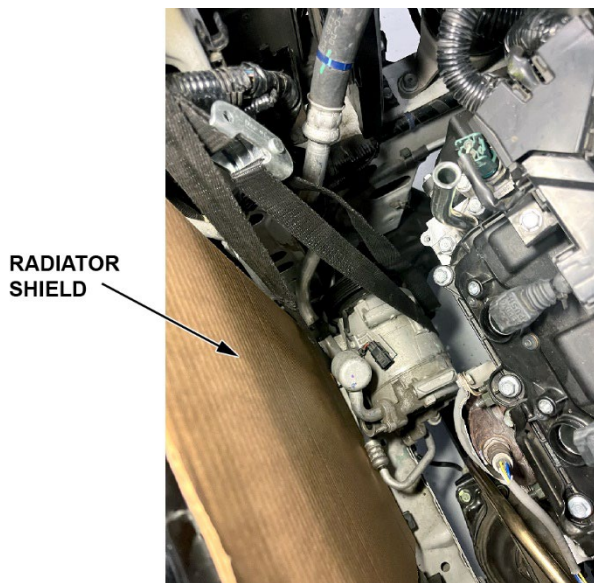

34. Remove the A/C compressor mounting bolts and move the A/C compressor forward to rest on the bulkhead frame by the radiator and secure with a strap.

NOTE: Do not disconnect the A/C hoses.

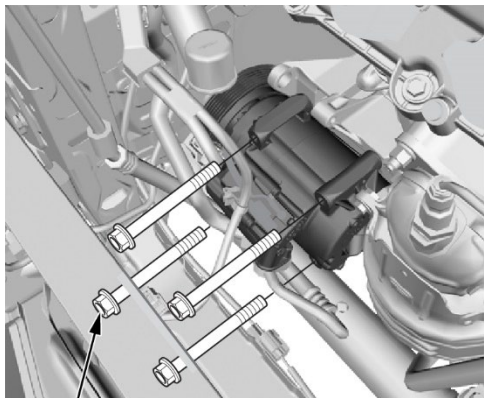

BOLTS (4)
22 N·m (16 lb-ft)



**SECURED
COMPRESSOR**

35. Remove the A/C compressor bracket leaving the drive belt auto tensioner attached. Torque to **45 N·m (33 lb-ft)** on installation.

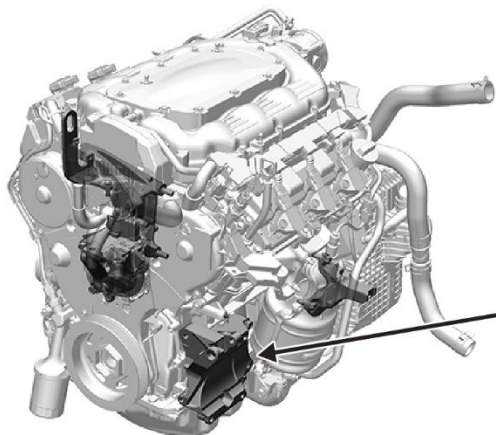

BOLTS (4)
45 N·m
(33 lb-ft)

3. Raise the vehicle.

36. Remove the engine oil pan.

⚠ CAUTION

Hot engine oil may continue to drip from the engine which can cause burns or eye damage. Wear proper protective equipment and eyewear to avoid injury.

NOTE:

- Remove the bolts securing the oil pan.
- Use a flat blade screwdriver to separate the oil pan from the engine block.
- Using a flat blade screwdriver, separate the oil pan from the engine block in the places shown.

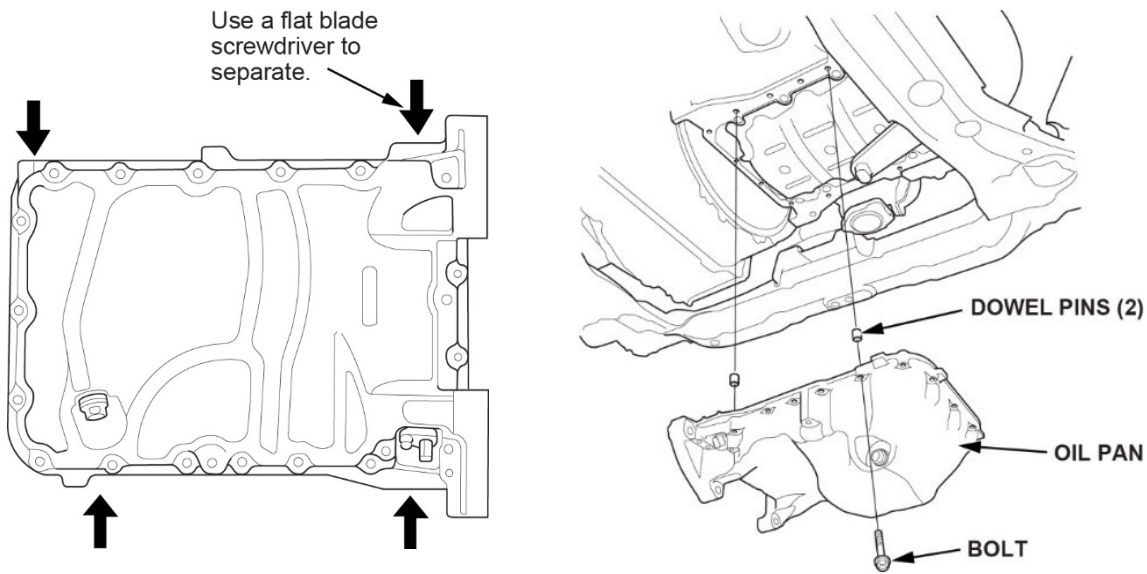

37. Remove the oil strainer and baffle plate.

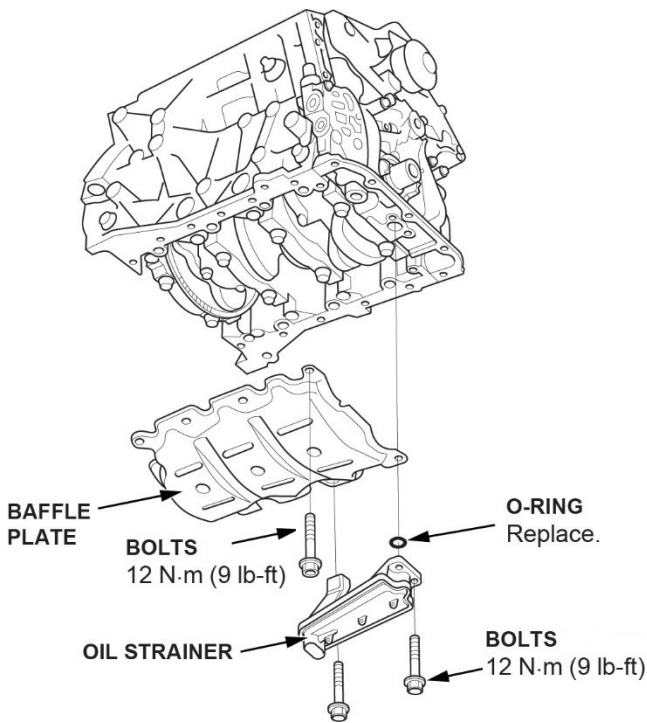

38. Remove the #1 main bearing cap.

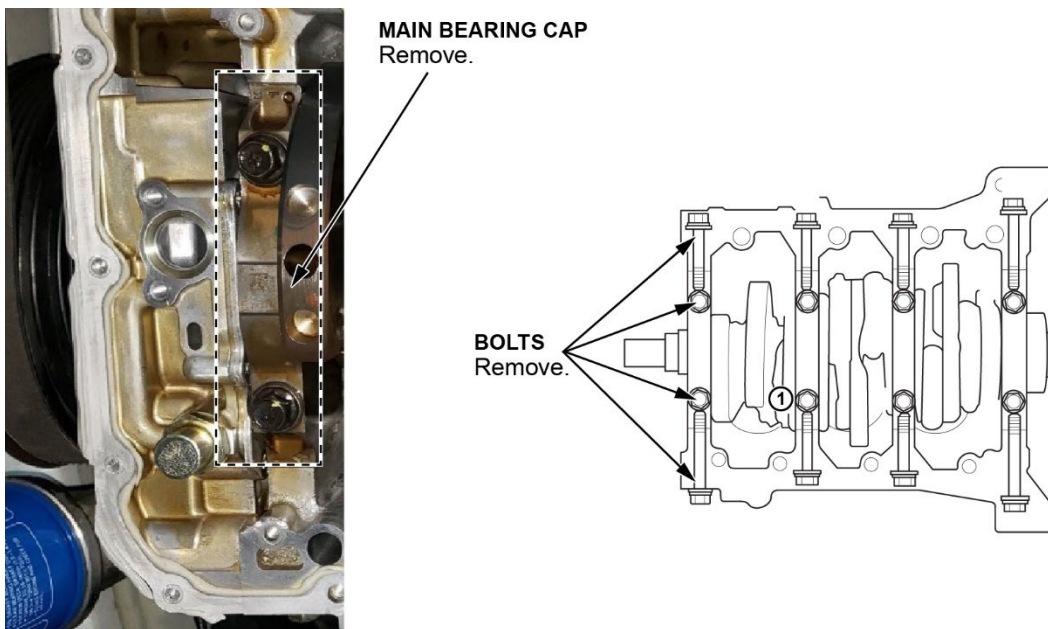

39. After removing the #1 main bearing cap, refer to the BEARING INSPECTION application tool to collect the journal codes.

40. Reinstall the #1 main bearing cap.

NOTE:

- Apply new engine oil to the bolt threads and flanges.
- Do not rotate the crankshaft during inspection.

1. Torque the 2 vertical bolts to **40 N·m (30 lb-ft)**.
2. Torque the 2 horizontal bolts to **49 N·m (36 lb-ft)**.
3. Torque the 2 vertical bolts again an additional **47°**.

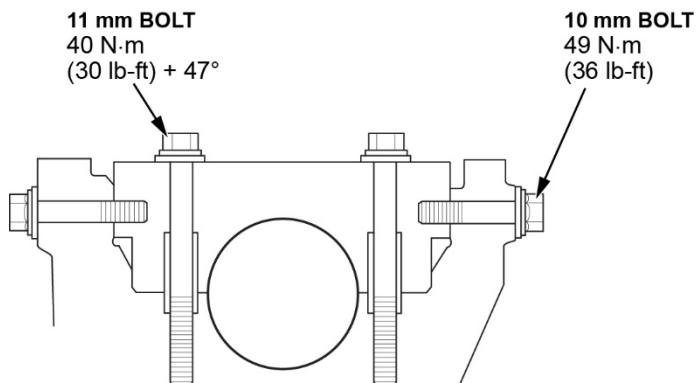

41. Clean and label each connecting rod cap with a paint marker (or otherwise suitable marking instrument) prior to removal. Make sure each rod cap has both the **cylinder #** and an **orientation arrow** pointing to the front of the vehicle.

NOTE:

- Do not confuse the existing marking on the side of the connecting rod and rod cap with the cylinder number. These are manufacturing marks referring to the size of the rod.
- Installing a rod cap incorrectly will result in engine knock and/or engine failure.

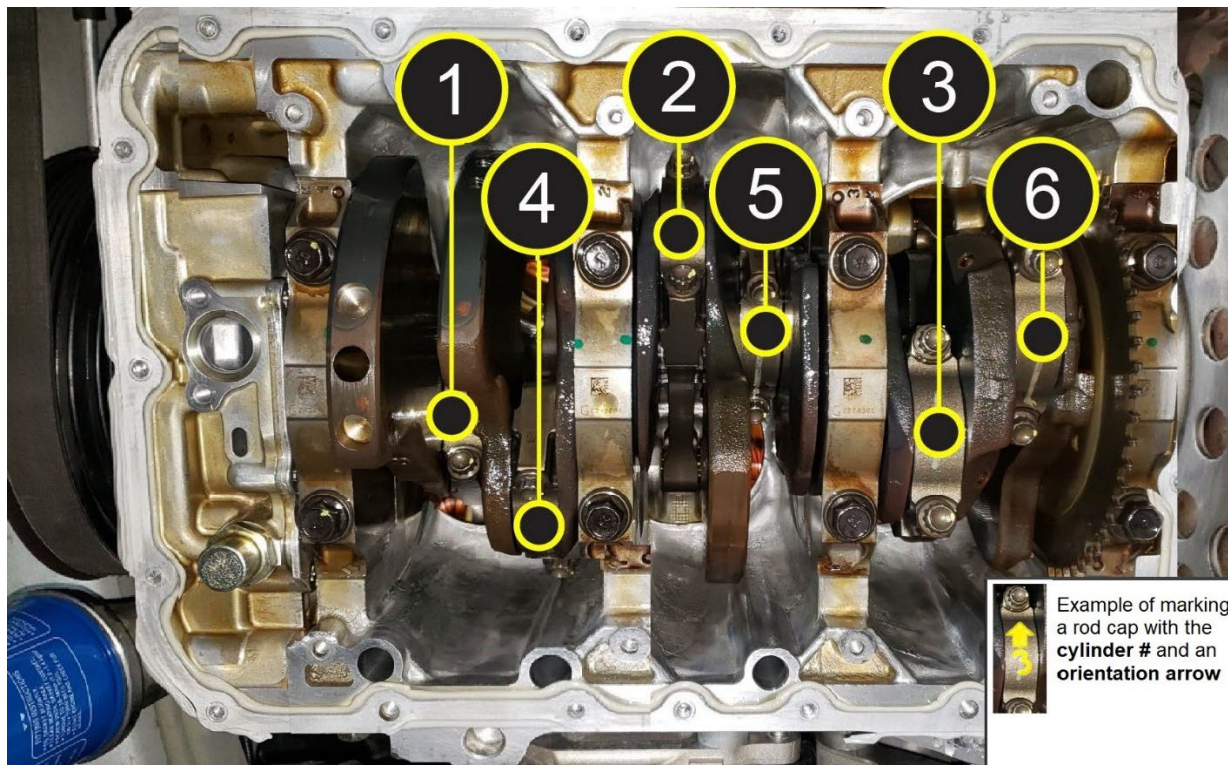

42. Log into the BEARING INSPECTION tool and follow the screen prompts.

NOTE: For BEARING INSPECTION application instruction, refer to this Job Aid: [\(Click HERE\)](#)

43. Rotate the engine to take pictures of all the connecting rod numbers.

1. Rotate crank 240° clockwise pictures of **connecting rods 1, 4, 5 and 6**. Enter the values and pictures into the BEARING INSPECTION application as directed.
2. Rotate the crankshaft approximately 120° clockwise until the **cylinder 3** rod is visible. Enter the value and take a picture as directed by the BEARING INSPECTION application.
3. Rotate the crankshaft approximately 120° clockwise until the **cylinder 2** rod is visible. Enter the value and take a picture as directed by the BEARING INSPECTION application.
4. Rotate the crankshaft approximately 240° clockwise until **cylinder 1** is back at **TDC**.

44. Confirm cylinder #1 is at top dead center (TDC). Align the pointer on the front upper cover with the No. 1 Piston TDC mark on the front camshaft pulley.

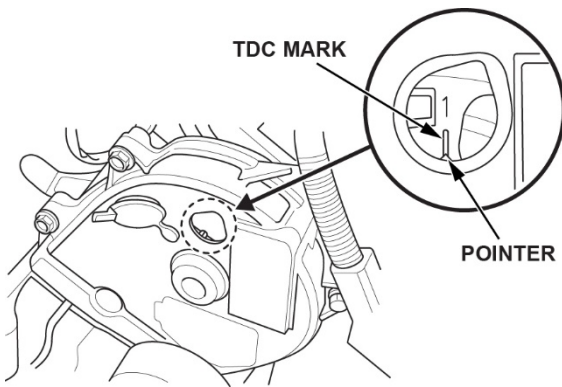

45. Install piston stoppers into cylinders 2,3,4, & 6.

NOTE: Make sure the stopper is clean, and hand tighten only!



PISTON STOPPER
P/N 07AAB-5G0200

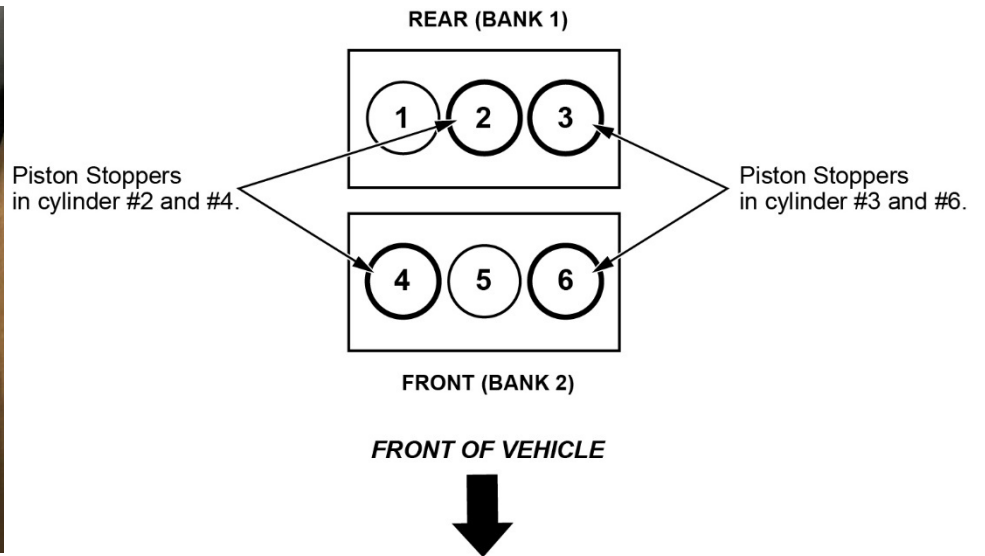

46. With cylinder 1 at TDC, mark the crankshaft pulley with a vertical line at the 6 o'clock position.



CRANKSHAFT PULLEY
Mark with a vertical line
from the 6 o'clock position.

47. Attach the crank angle gauge to the crankshaft pulley with position #1 correctly aligned at the 6 o'clock position.



Click here to view video:



CRANK ANGLE GAUGE
P/N 07AAJ-5G0A100

48. Attach a large, commercially available zip tie to the subframe below the crankshaft pulley. The zip tie will be a **reference indicator** for a correct timing wheel position.

NOTE:

- Make sure it is pointing up at the 6 o'clock position on the pulley.
- The zip tie should extend roughly 8" to 12" over the subframe.



ZIP TIE
Attach a zip tie to the frame and line up as shown.

49. Make sure the Bearing Photo Box (**TOOL NUMBER: 07AAK-5J2A200**) and inspection tray are available for use.

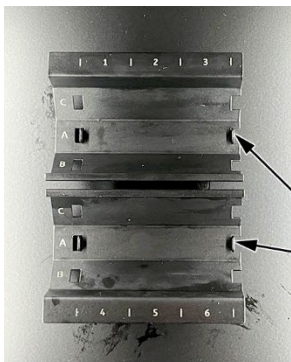

BEARING PHOTO BOX

INSPECTION TRAY



50. Make sure the **cylinder 1** is at TDC (**position #1**).



CRANK
ANGLE
GAUGE

51. Remove the connecting rod bearing cap and lower bearing for cylinders 1,3,5, and 6.

Step/Crankshaft Position	Cylinder 1 Bearing Cap and Lower Bearings	Cylinder 3 Bearing Cap and Lower Bearings	Cylinder 5 Bearing Cap and Lower Bearings	Cylinder 6 Bearing Cap and Lower Bearings
#1/At TDC	Remove	Remove	Remove	Remove

Click here to view video:



NOTE:

- Follow the removal of the connecting rod steps precisely to prevent damage to the crank journal and connecting rods.
- The next steps involve manually moving the piston/rod assemblies while disconnected from the crankshaft. Moving the piston/rod assembly too far in either direction can damage the piston and/or oil jet.
- Thoroughly clean the bearing with a clean shop towel after removal. No oil should be present. **Do not use any solvents.**

52. Place the removed lower bearings from **cylinders 1,3,5, and 6** into the inspection tray.

NOTE:

- Thoroughly clean the bearings with a clean shop towel prior to placing the bearing in the inspection tray. No oil should be present. **Do not use any solvents.**
- **Place** the removed bearings into the inspection tray at the correct position. For example, the **cylinder 1 bearings** should be in the **#1 slot** in the **tray**. **Upper and lower bearing arrangement in the tray does not matter.**

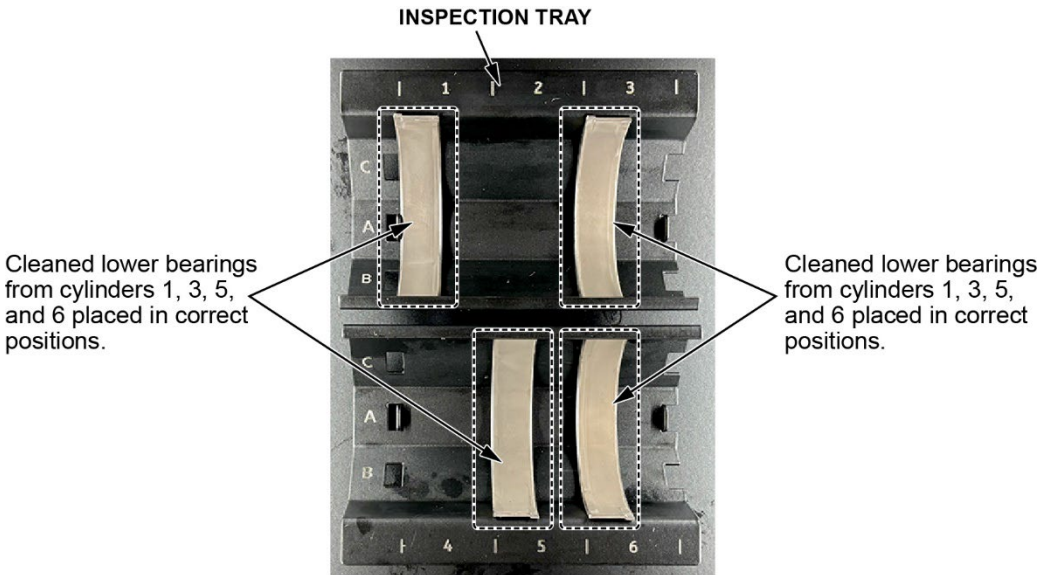

53. Rotate the crankshaft clockwise to the **#2 position** (TDC +45°).



Rotate the crank clockwise to the #2 position.

54. Remove the rod bearing cap and lower bearing from cylinder 2.

Step/Crankshaft Position	Cylinder 2 Bearing Cap and Lower Bearings
#2/TDC +45°	Remove

NOTE:

- Follow the removal of the connecting rod bearing steps precisely to prevent damage to the crank journal and connecting rods.
- The next steps involve manually moving the piston/rod assemblies while disconnected from the crankshaft. Moving the piston/rod assembly too far in either direction can damage the piston and/or oil jet.
- Thoroughly clean the bearing with a clean shop towel after removal. No oil should be present. **Do not** use any solvents.

55. Place the removed lower bearing from **cylinder 2** into the inspection tray.

NOTE:

- Thoroughly clean the bearing with a clean shop towel prior to placing in the inspection tray. No oil should be present. **Do not use any solvents.**
- **Place** the removed bearings into the inspection tray at the correct position. For example, the **cylinder 1 bearings** should be in the **#1 slot** in the **tray**. **Upper and lower bearing arrangement in the tray does not matter.**



56. Remove the cylinder 2 upper connecting rod bearing.

Step/Crankshaft Position	Cylinder 2 Upper Bearing
#2/TDC +45°	Remove

Click here to view video:



M8 ROD HOLDER
P/N 07AAB-5G0A100



NOTE:

- Follow the removal of the connecting rod bearing steps precisely to prevent damage to the crank journal and connecting rods.
- The next steps involve manually moving the piston/rod assemblies while disconnected from the crankshaft. Moving the piston/rod assembly too far in either direction can damage the piston and/or oil jet.
- Thoroughly clean the bearing with a clean shop towel after removal. No oil should be present. **Do not use any solvents.**

EXAMPLE OF USING THE M8 ROD HOLDER TOOL

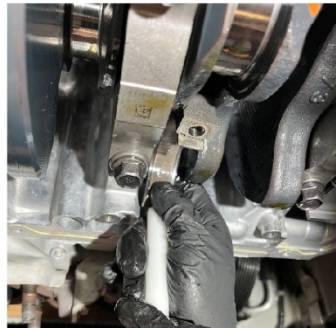

1. Thread the M8 rod holder tool into the connecting rod bolt hole.
2. Carefully push the connecting rod up until the connecting rod clears the crankshaft journal.
3. Swing the connecting rod to the side, then pull down just enough to gain access to the upper bearing.
4. Remove the upper bearing by sliding it to the side until it releases from the connecting rod.
5. Using the M8 rod holder tool, carefully push the connecting rod back up until it contacts the piston stopper.
6. Remove the M8 rod holder tool.
7. Thoroughly clean the bearing with a clean shop towel to remove all oil residue. **Do not use any solvents.**

57. Place the removed **upper bearing** from **cylinder 2** into the inspection tray.

NOTE:

- Thoroughly clean the bearing with a clean shop towel prior to placing in the inspection tray. No oil should be present. **Do not use any solvents.**
- **Place** the removed bearings into the inspection tray at the correct position. For example, the **cylinder 1 bearings** should be in the **#1 slot** in the **tray**. **Upper and lower bearing** arrangement in the tray **does not matter**.

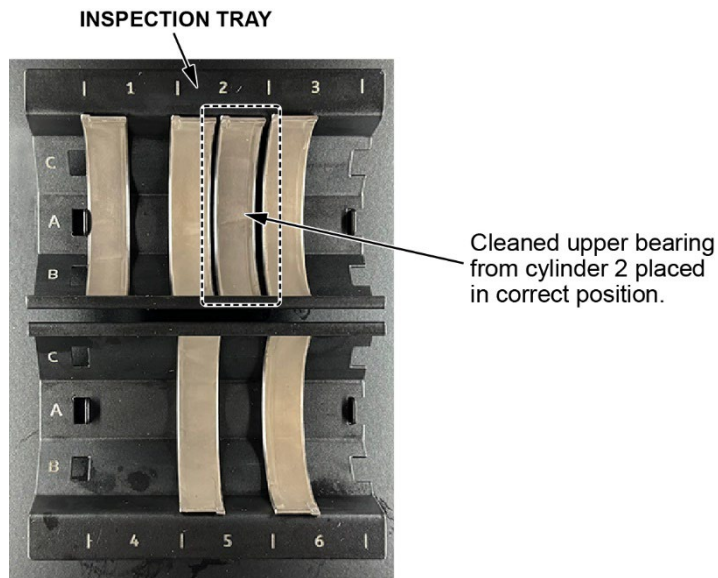

58. Rotate the crankshaft counterclockwise to the **#3 position** (TDC -45°).

Rotate the crank counterclockwise to the #3 position.



59. Remove the **rod bearing cap and lower bearing** from **cylinder 4**.

Step/Crankshaft Position	Cylinder 4 Rod Cap and Lower Bearing
#3/TDC -45°	Remove

NOTE:

- Follow the removal of the connecting rod steps precisely to prevent damage to the crank journal and connecting rods.
- The next steps involve manually moving the piston/rod assemblies while disconnected from the crankshaft. Moving the piston/rod assembly too far in either direction can damage the piston and/or oil jet.
- Thoroughly clean the bearing with a clean shop towel after removal. No oil should be present. **Do not use any solvents.**

60. Place the removed **lower bearing** from **cylinder 4** into the inspection tray.

NOTE:

- Thoroughly clean the bearing with a clean shop towel prior to placing in the inspection tray. No oil should be present. **Do not use any solvents.**
- **Place** the removed bearings into the inspection tray at the correct position. For example, the **cylinder 1 bearings** should be in the **#1 slot** in the **tray**. **Upper and lower bearing** arrangement in the tray **does not matter**.



61. Remove the cylinder 3 and cylinder 4 upper connecting rod bearings.

NOTE:

- Follow the removal of the connecting rod bearings precisely to prevent damage to the crank journal and connecting rods.
- The next steps involve manually moving the piston/rod assemblies while disconnected from the crankshaft. Moving the piston/rod assembly too far in either direction can damage the piston and/or oil jet.
- Thoroughly clean the bearing with a clean shop towel after removal. No oil should be present. **Do not use any solvents.**
- Use the M8 as needed, hand tighten only!

Step/Crankshaft Position	Cylinder 3 Upper Bearing	Cylinder 4 Upper Bearing
#3/TDC -45°	Remove	Remove

EXAMPLE OF USING THE M8 ROD HOLDER:

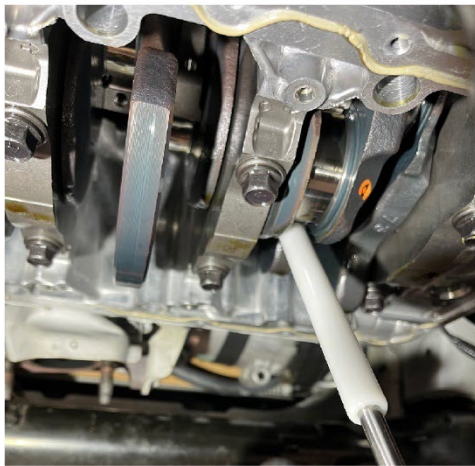

1. Thread the M8 rod holder into the connecting rod bolt hole.
2. Carefully push the connecting rod up until the connecting rod clears the crankshaft journal.
3. Swing the connecting rod to the side, then pull down just enough to gain access to the upper bearing.
4. Remove the upper bearing by sliding it to the side until it releases from the connecting rod.
5. Using the M8 rod holder, carefully push the **cylinder 3** connecting rod back up until it clears the crankshaft journal.

NOTE: Leave **cylinder 4** connecting rod in the lower position, **do not** push back up.

6. Remove the rod holder.
7. Thoroughly clean the bearings with a clean shop towel to remove all oil residue. **Do not use any solvents.**

59. Place the removed **upper bearings from cylinder 3 and 4** into the inspection tray.

NOTE:

- Thoroughly clean the bearing with a clean shop towel prior to placing in the inspection tray. No oil should be present. **Do not use any solvents.**
- **Place** the removed bearings into the inspection tray at the correct position. For example, the **cylinder 1 bearings** should be in the **#1 slot** in the **tray**. **Upper and lower bearing arrangement in the tray does not matter.**

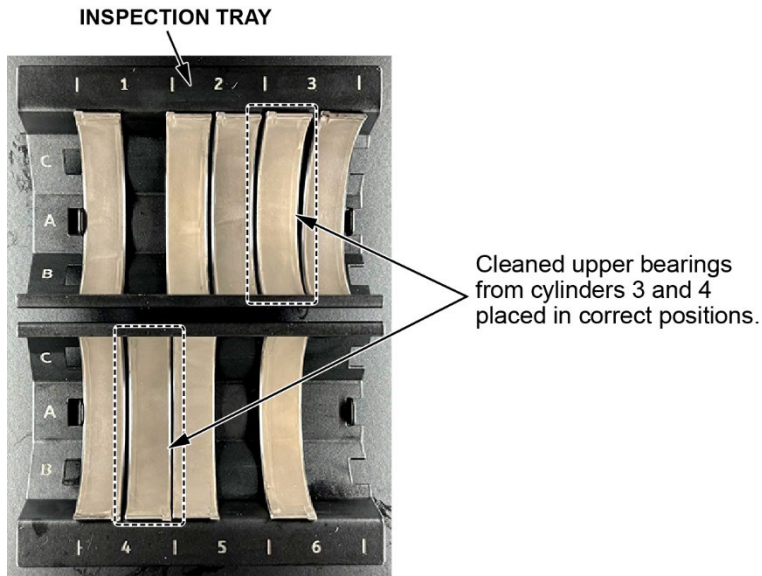

60. Rotate the crankshaft clockwise to the **#4 position** (TDC +90°).

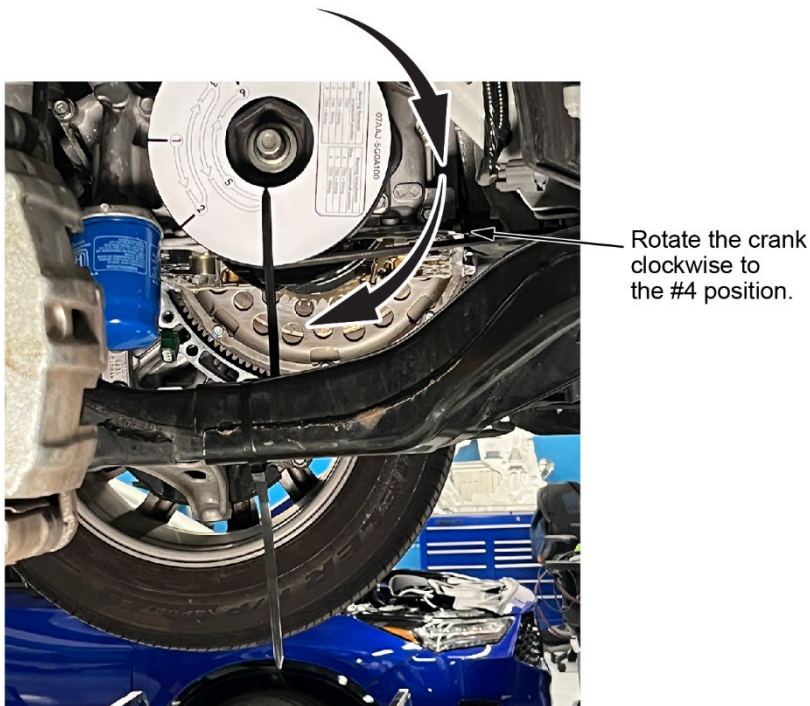

61. Remove the upper bearing from cylinders 1, 5, and 6.

Step/Crankshaft Position	Cylinder 1 Upper Bearing	Cylinder 5 Upper Bearing	Cylinder 6 Upper Bearing
#4/TDC +90°	Remove	Remove	Remove

NOTE:

- Follow the removal of the connecting rod steps precisely to prevent damage to the crank journal and connecting rods.
 - The next steps involve manually moving the piston/rod assemblies while disconnected from the crankshaft. Moving the piston/rod assembly too far in either direction can damage the piston and/or oil jet.
 - Thoroughly clean the bearing with a clean shop towel after removal. No oil should be present. **Do not use any solvents.**
 - Use the rod holder tool as necessary, hand tighten only.
1. Thread the rod holder tool into the connecting rod bolt hole.
 2. Carefully push the connecting rod up until the connecting rod clears the crankshaft journal.
 3. Swing the connecting rod to the side, then pull down just enough to gain access to the upper bearing.
 4. Remove the upper bearing by sliding it to the side until it releases from the connecting rod.
 5. Using the rod holder tool, carefully push the connecting rod back up until it contacts the piston stopper.
 6. Remove the rod holder tool.
 7. Thoroughly clean the bearings with a clean shop towel to remove all oil residue. **Do not use any solvents.**

62. Place the removed **upper bearings** from **cylinders 1, 5, and 6** into the inspection tray.

NOTE:

- Thoroughly clean the bearing with a clean shop towel prior to placing in the inspection tray. No oil should be present. **Do not use any solvents.**
- **Place** the removed bearings into the inspection tray at the correct position. For example, the **cylinder 1 bearings** should be in the **#1 slot** in the **tray**. **Upper and lower bearing** arrangement in the tray **does not matter**.

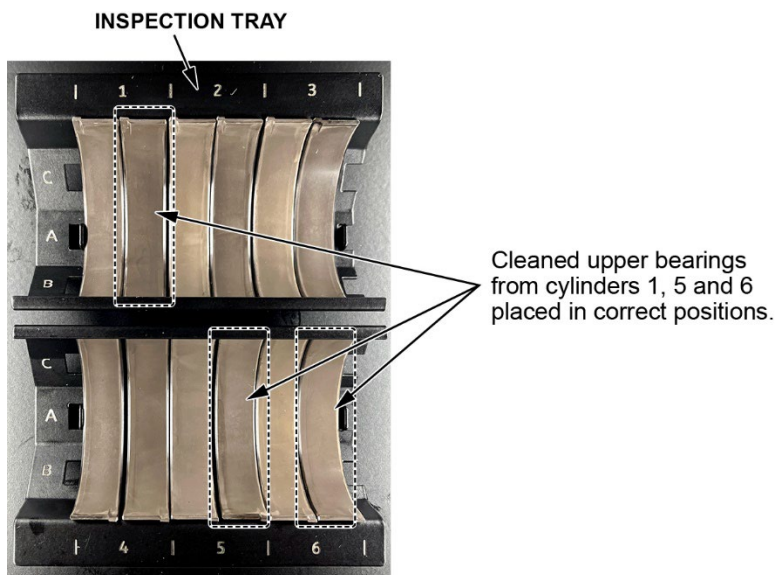

63. Make sure the bearings are fully seated and level with the edge of the inspection tray.

- The bearing's indexing tab should be lined up at the numbers.
- The flat edge of the bearing should be inside the lip.
- All bearings should be fully seated.

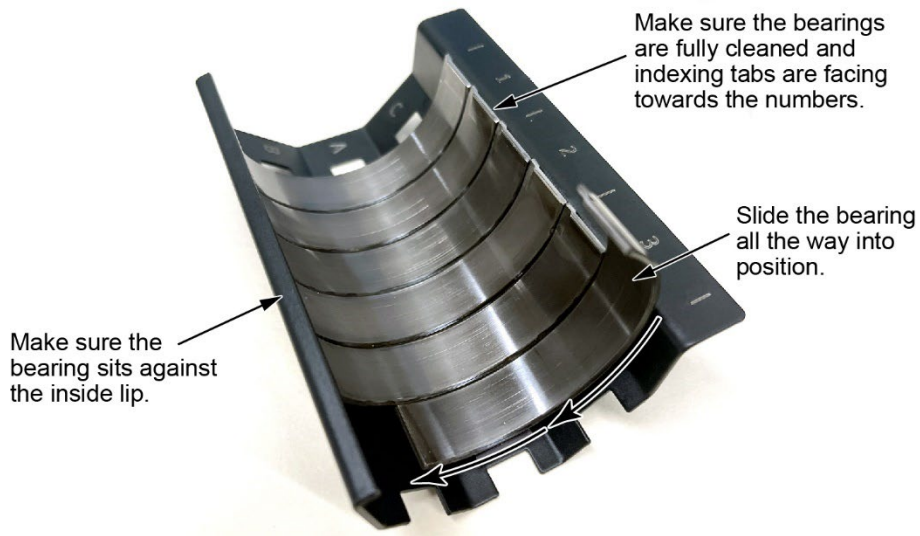

64. Remove the photo box cover and place the inspection trays into the bearing photo box.

NOTE: When taking photos make sure there are no objects in the bearing photo box, only the bearing trays with bearings.

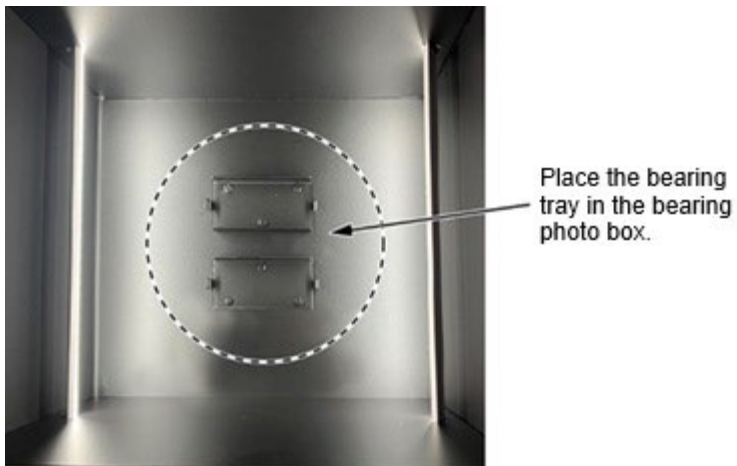

65. Confirm the following is ready on the bearing photo box:

1. Lights at the brightest setting.

NOTE: The lighting can be adjusted with a long hold on the button.

1. Both bearing trays in position A with non-numbered sides facing each other.
2. The O-rings are set on the lights to prevent an outside light source.

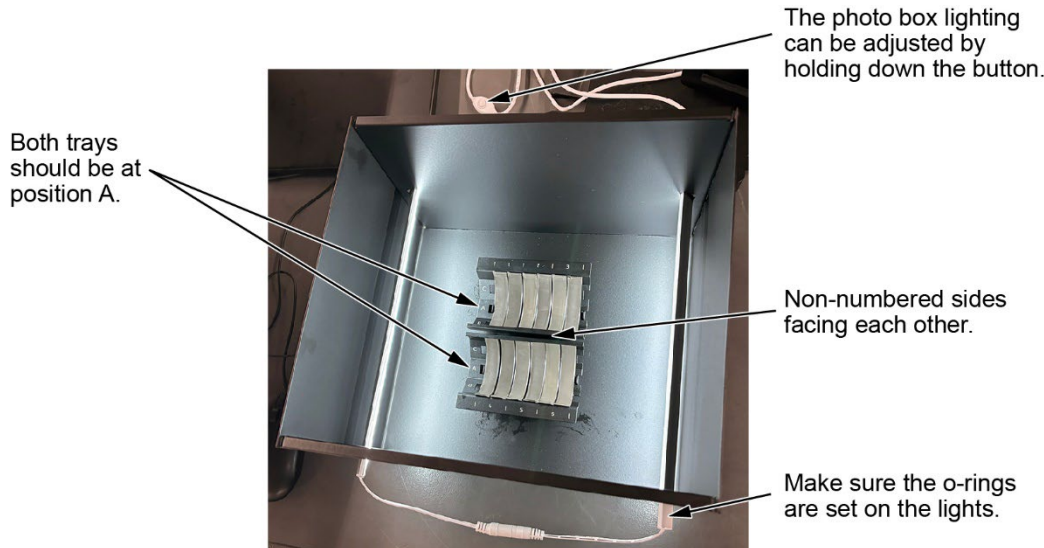

66. Using the BEARING INSPECTION application, follow the instructions to take bearing photos in positions A, B, and C. Follow the prompts when submitting the photos.

NOTE:

- For BEARING INSPECTION application instruction, refer to this Job Aid: [\(Click HERE\)](#)
- Technicians are now required to center-punch all 12 bearings as instructed on step 76 to prevent reuse of the bearings. **DO NOT** center punch the bearing until instructed by the application. Submitting any photos with center-punches for Photos A, B and C **WILL BE REJECTED**.
- Use the camera tap focus for a clear image.
- Any unclear images will not be accepted.
- Follow the BEARING INSPECTION application prompts after photo submission.

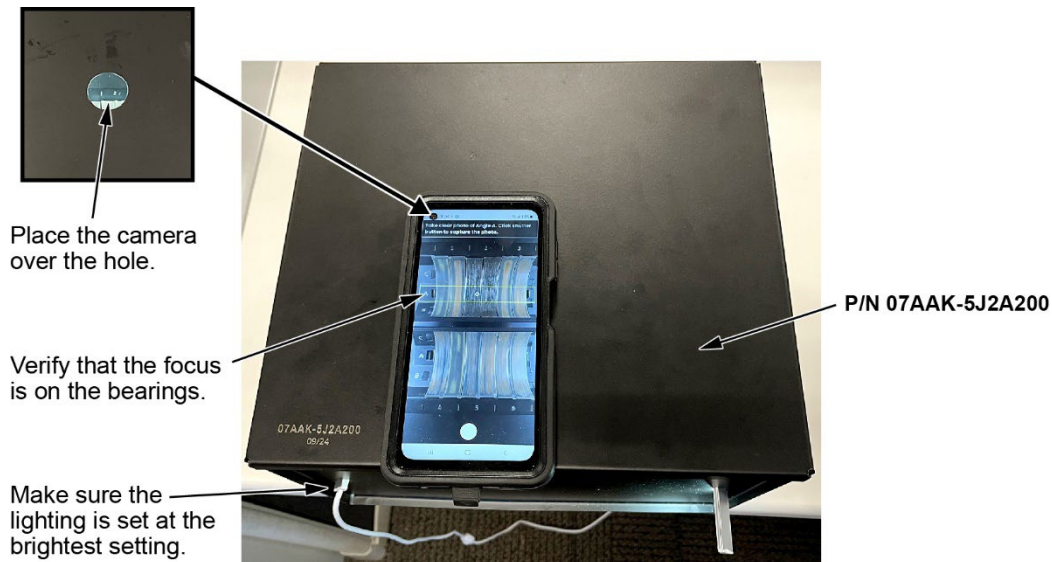

When taking the photos:

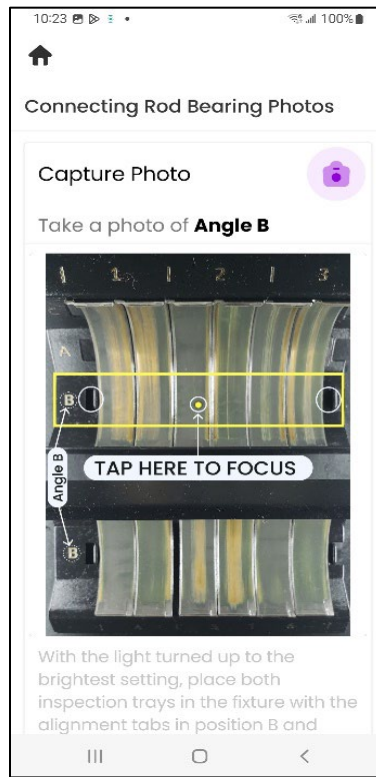
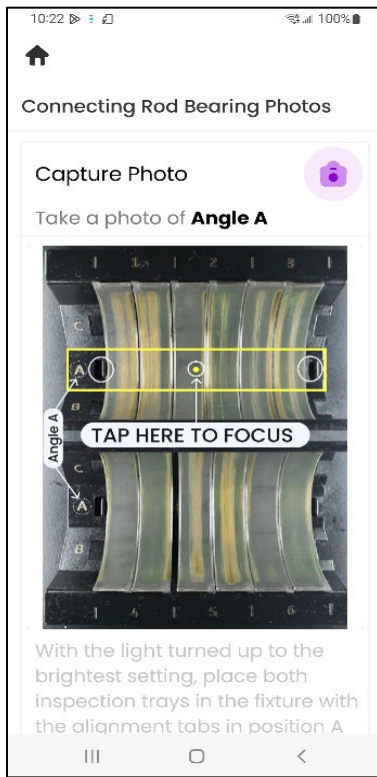

Centered punch bearings:



67. When the Bearing Inspection Inquiry Team completes the review and assigns a repair method, the following will occur:

1. The Bearing Inspection Recall Status screen will update with the specified repair.
2. If optional mobile numbers are included in the technician's contact information, a text message will be issued to advise the inspection is complete and refers the technician to the Bearing Inspection Repair Direction Sheet that was issued to the email addresses on file.
3. An email, which provides a link to the Bearing Inspection Repair Direction Sheet, is issued to all addresses on file.

The Repair Direction Sheet provides the Inspection and Repair Warranty Codes required to file the warranty claims. If Bearing Only or Crankshaft replacement is required, the Repair Direction Sheet provides the bearing sizes and graphics identifying the location in which they should be installed.

REPAIR #1 INSTALL RECOMMENDED BEARINGS

NOTE: DO NOT contact Tech Line for any inquiries about this safety recall. If instructed by the application tool, call the Bearing Inspection Inquiry Team at (800) 824-6632 (**Select Option #9**).

1. Follow the **Repair Type** instructions on the emailed Repair Direction sheet. Make sure the VIN sheet matches the vehicle.

NOTE:

- Follow the **Repair Type** instructions exactly as recommended.
- Use the **Warranty Inspection and Repair Codes** for the warranty claim.



Bearing Inspection Repair Direction

Date: 2025-05-23
Time: 05:36 PM
Page: 1

Car Information:

Case #: A00028 VIN: [REDACTED] Exterior Color: WHITE DIAMOND PEARL
Dealer #: [REDACTED] EIN: [REDACTED] Interior Color: PARCHMENT
Model: [REDACTED] Year: 2018

Warranty Information:

	Warranty Code	Failed Part Number	
Inspection	[REDACTED]	[REDACTED]	<i>(Enter the Warranty Code into the Test Code field in the claim form corresponding to the failed part number)</i>
Repair	[REDACTED]	[REDACTED]	

Next Step: Repair the Car

Repair Type: Rod Bearings Only Service Bulletin: MDX: B24-001

Bearing Information:

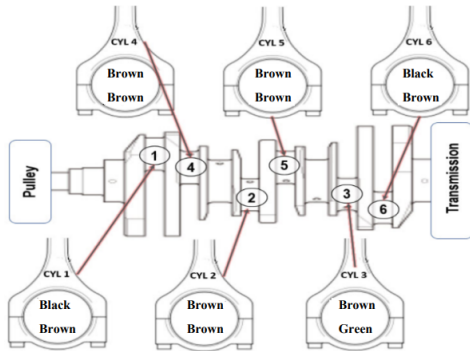

2. Inspect the connecting rod bolts:

- Measure the diameter of each connecting rod bolt at point A and point B.
- Calculate the difference in diameter between point A and point B.
Difference in diameter specification: 0–0.1 mm (0–0.004 in)
- If the difference in diameter is out of tolerance, replace the connecting rod bolt.

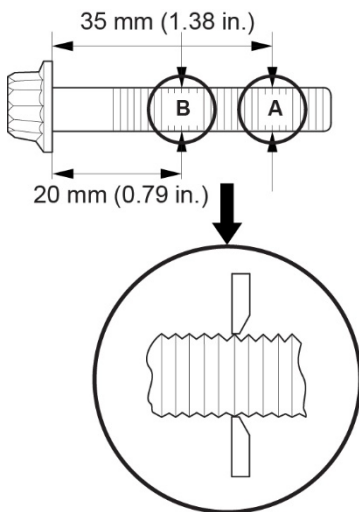

3. Apply a light coating of oil to all connecting rod journals.
4. While the crankshaft is still at crank angle gauge **position #4** (TDC +90°), install the **upper bearing** to the connecting rod for **cylinders 1, 5, and 6**.

NOTE:

- Make sure the bearing indexing tabs are properly oriented during installation.
- Follow the install of the connecting rod steps precisely to prevent damage to the crank journal and connecting rods.

Step/Crankshaft Position	Cylinder 1 Upper bearings	Cylinder 5 Upper bearings	Cylinder 6 Upper bearings
#4/TDC +90°	Install	Install	Install

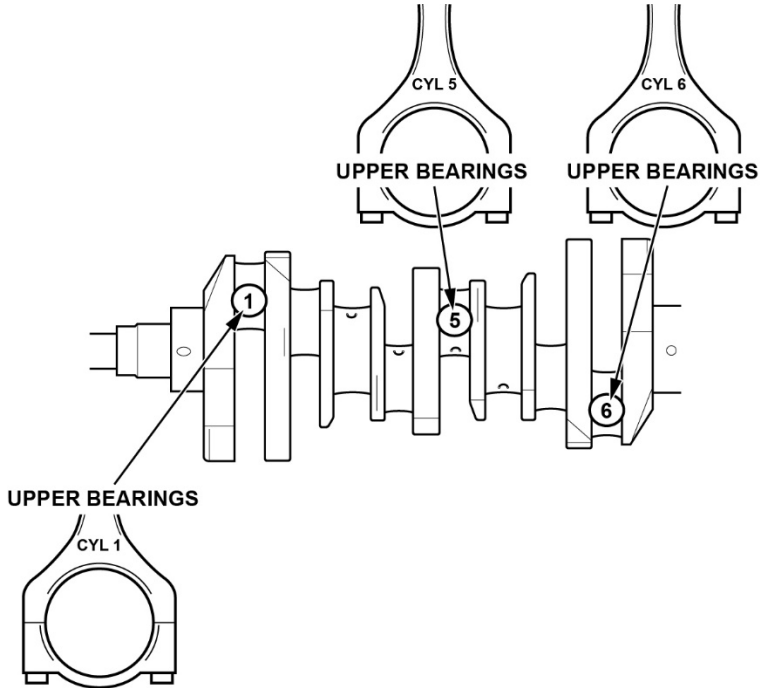

5. Install the connecting rod cap and lower bearing to the connecting rod for cylinder 5.

NOTE:

- Make sure the bearing indexing tabs are properly oriented during installation.
- Apply new engine oil to the bolt threads and bolt flanges.
- If you tightened the connecting rod bolt beyond the specified angle, remove and inspect the connecting rod bolt. Do not loosen it back to the specified angle.
- Use a commercially available torque angle meter.
- Use the M8 Rod Holder tool as needed, this includes resting against the journal as a guide.
- Follow the install of the connecting rod steps precisely to prevent damage to the crank journal and connecting rods.

Step/Crankshaft Position	Cylinder 5 Rod Cap and Lower Bearing
#4/TDC +90°	Install

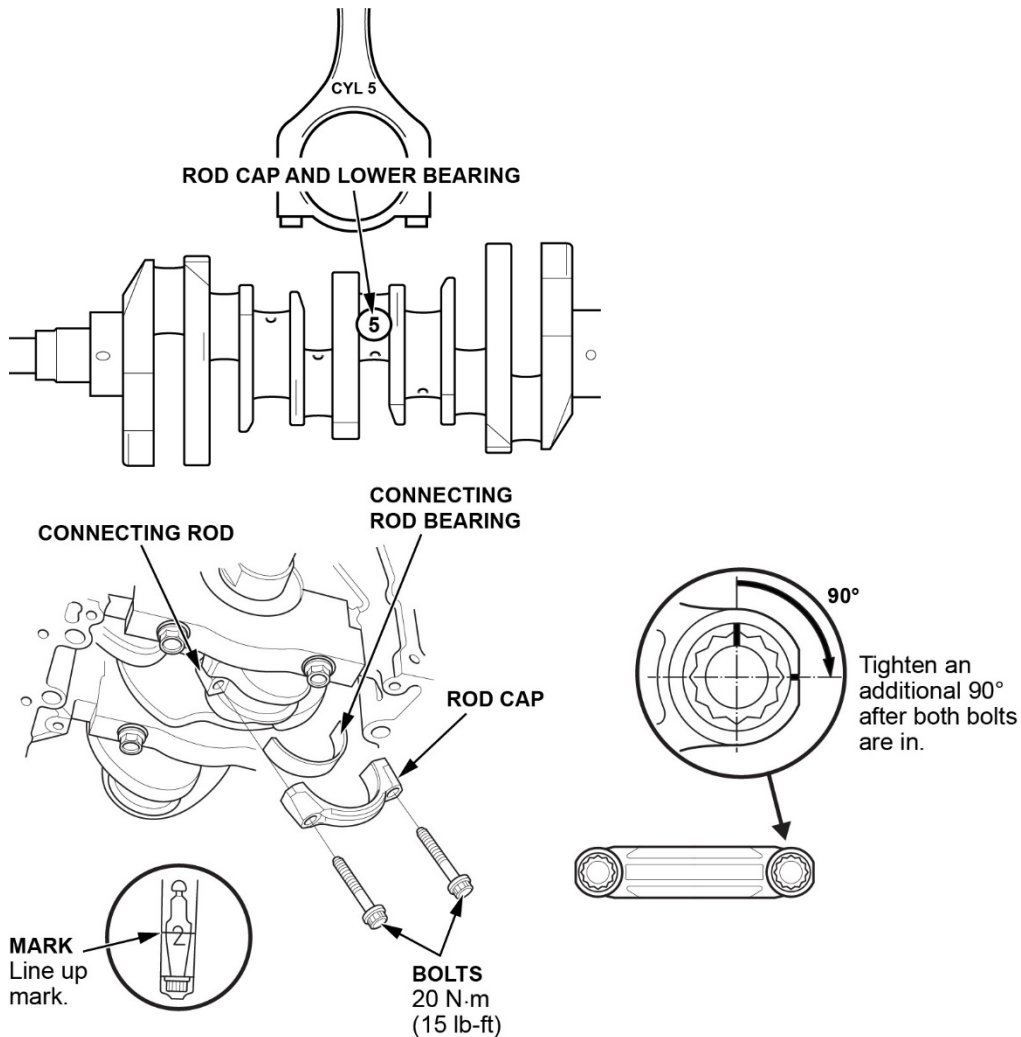

6. Rotate the crankshaft counterclockwise to crank angle gauge **position #5** (TDC +45°).

Rotate the crank counter-clockwise to the #5 position.



7. Install the **upper bearing** to the connecting rod for **cylinder 2**.

Step/Crankshaft Position	Cylinder 2 Upper Bearings
#5/TDC +45°	Install

- Follow the install of the connecting rod steps precisely to prevent damage to the crank journal and connecting rods.

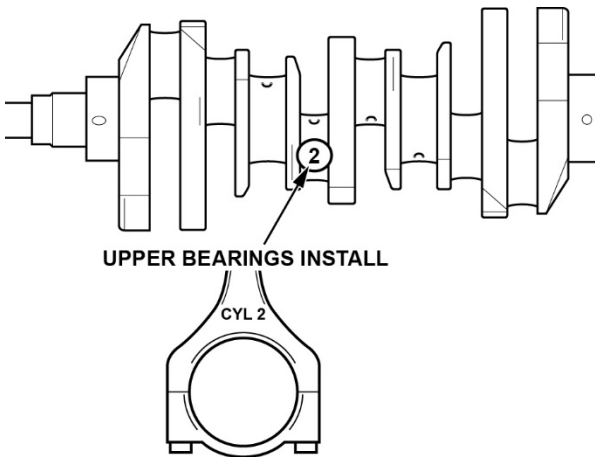

8. Without moving the crank, install the **rod cap and lower bearing** to the connecting rod **for cylinders 2 and 6**.

NOTE:

- Make sure the bearing indexing tabs are properly oriented during installation.
- Apply new engine oil to the bolt threads and bolt flanges.
- If you tightened the connecting rod bolt beyond the specified angle, remove and inspect the connecting rod bolt. Do not loosen it back to the specified angle.
- Use a commercially available torque angle meter.
- Use the M8 Rod Holder tool as needed, this includes resting against the journal or otherwise.
- Follow the install of the connecting rod steps precisely to prevent damage to the crank journal and connecting rods.

Step/Crankshaft Position	Cylinder 2 Rod Cap and Lower Bearings	Cylinder 6 Rod Cap and Lower Bearings
#5/TDC +45°	Install	Install

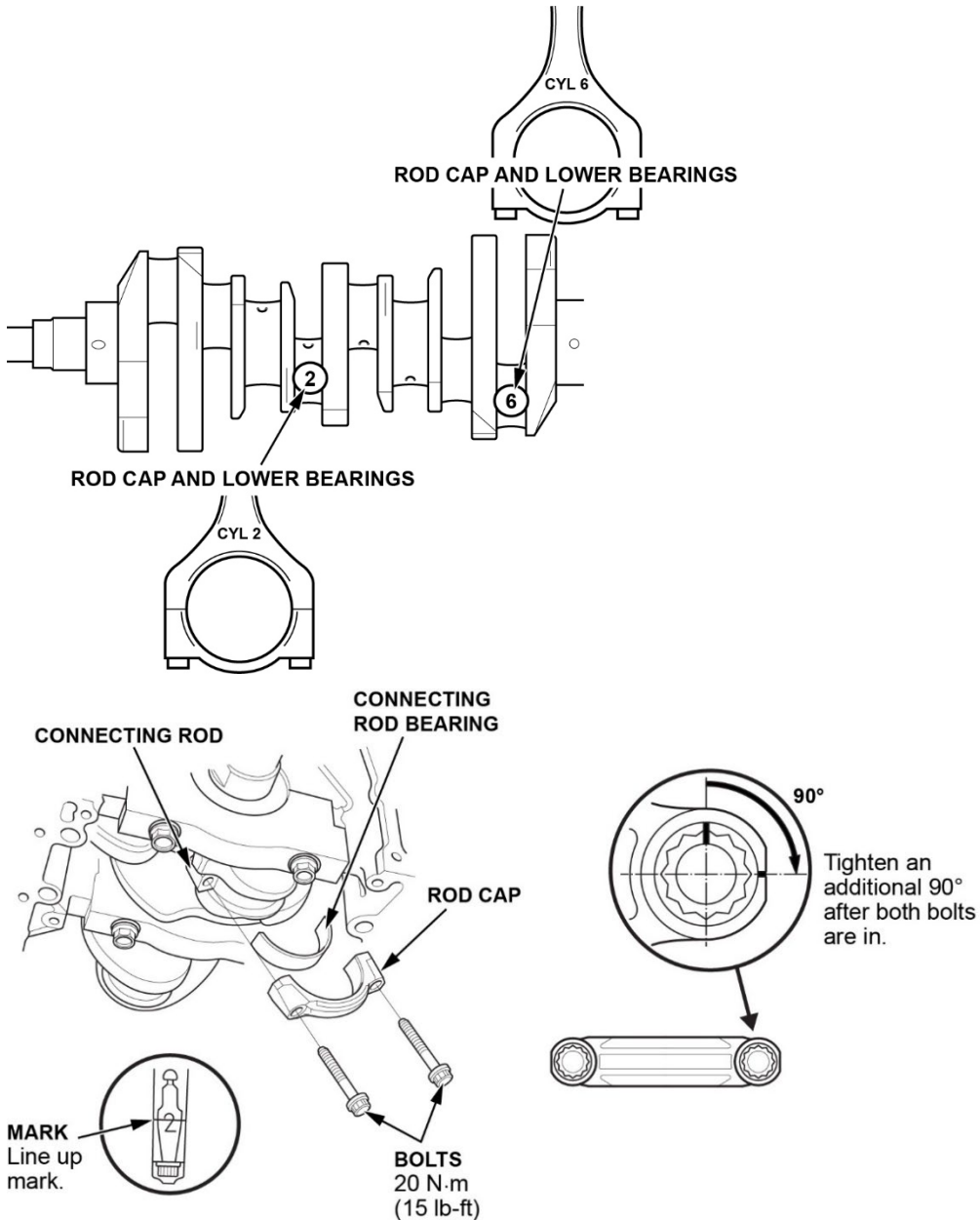

9. Rotate the crankshaft counterclockwise to crank angle gauge **position #6** (TDC -60°).

Rotate the crank counterclockwise to the #6 position.



10. Install the **upper bearings** to the connecting rods for **cylinders 3 and 4**.

Step/Crankshaft Position	Cylinder 3 Upper Bearings	Cylinder 4 Upper Bearings
#6/TDC -60°	Install	Install

- Follow the install of the connecting rod steps precisely to prevent damage to the crank journal and connecting rods.

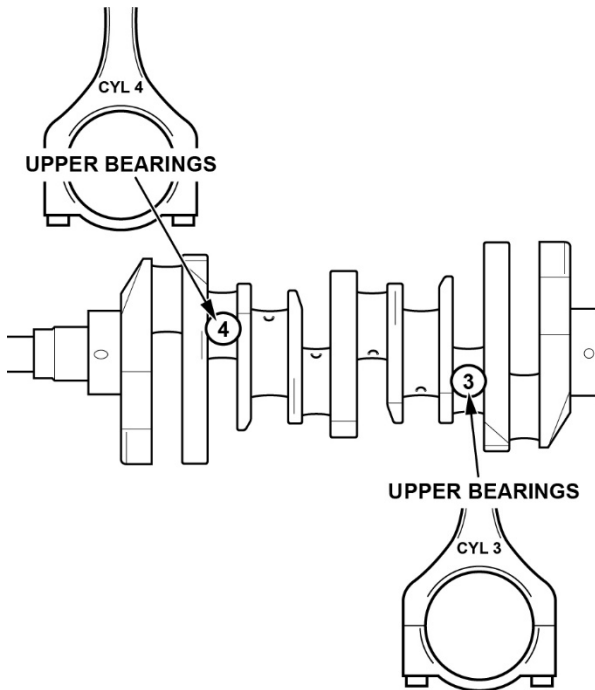

11. Without rotating the crank, install the **rod caps and lower bearings** to the connecting rod **for cylinders 1, 3, and 4**.

- Make sure the bearing indexing tabs are properly oriented during installation.
- Apply new engine oil to the bolt threads and bolt flanges.
- If you tightened the connecting rod bolt beyond the specified angle, remove and inspect the connecting rod bolt. Do not loosen it back to the specified angle.
- Use a commercially available torque angle meter.
- Use the M8 Rod Holder tool as needed, this includes resting against the journal or otherwise.
- Follow the install of the connecting rod steps precisely to prevent damage to the crank journal and connecting rods.

Step/Crankshaft Position	Cylinder 1 Rod Cap and Lower Bearings	Cylinder 3 Rod Cap and Lower Bearings	Cylinder 4 Rod Cap and Lower Bearings
#6/TDC -60°	Install	Install	Install

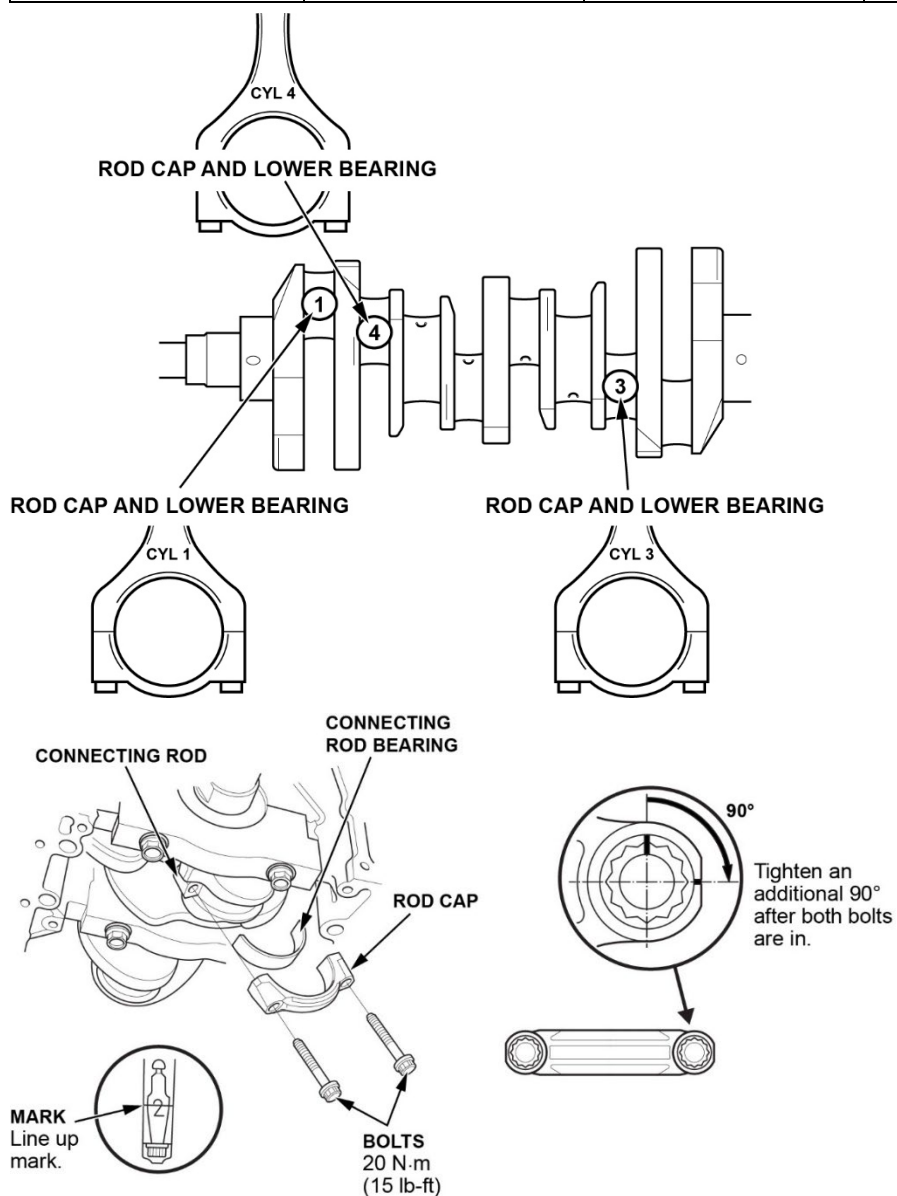

12. Remove the crank angle gauge and zip tie.

13. Lower the vehicle and remove the piston stoppers.

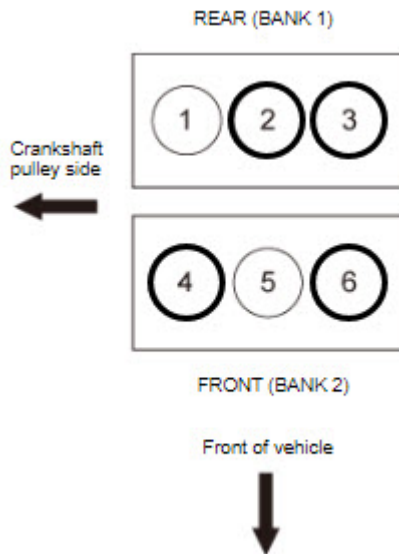

14. Raise the vehicle.

15. Rotate the crankshaft **360 degrees** to check for binding of rod bearings.

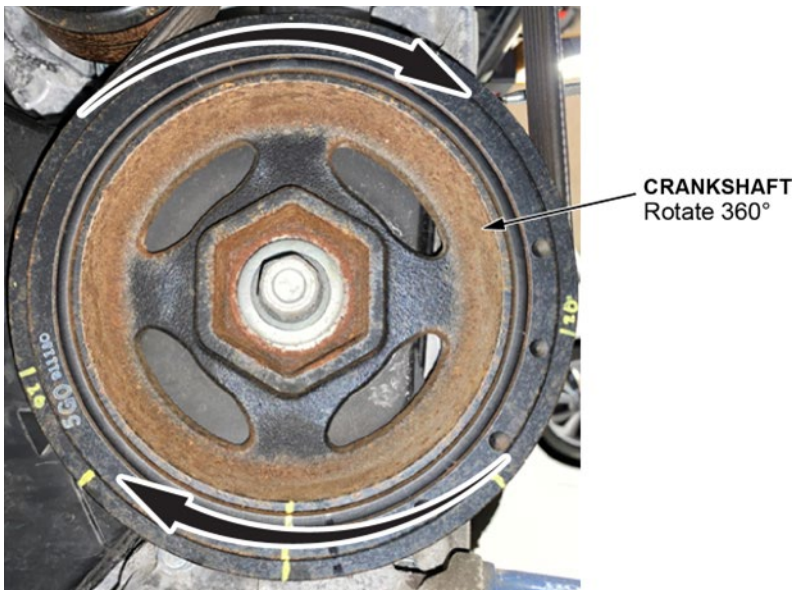

16. Install the baffle plate and oil strainer.

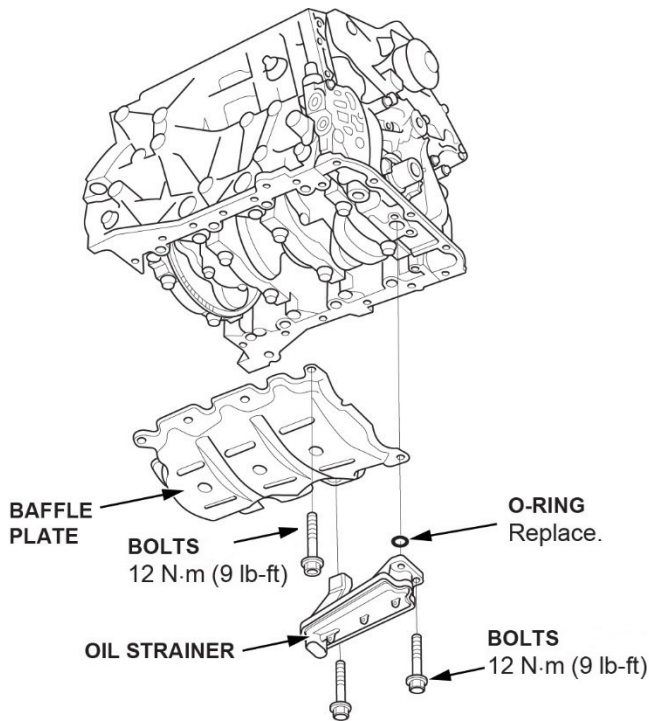

17. Install the engine oil pan.

1. Remove all of the old liquid gasket from the oil pan mating surfaces, the bolts, and the bolt holes.
2. Clean and dry the oil pan mating surfaces.
3. Apply liquid gasket to the oil pan mating surface of the engine block and to the inside edge of the threaded bolt holes. Install the component within 5 minutes of applying the liquid gasket.

NOTE: If too much time has passed after applying the liquid gasket, remove the old liquid gasket and residue, then reapply new liquid gasket.

4. Install the dowel pins.
5. Install the oil pan.

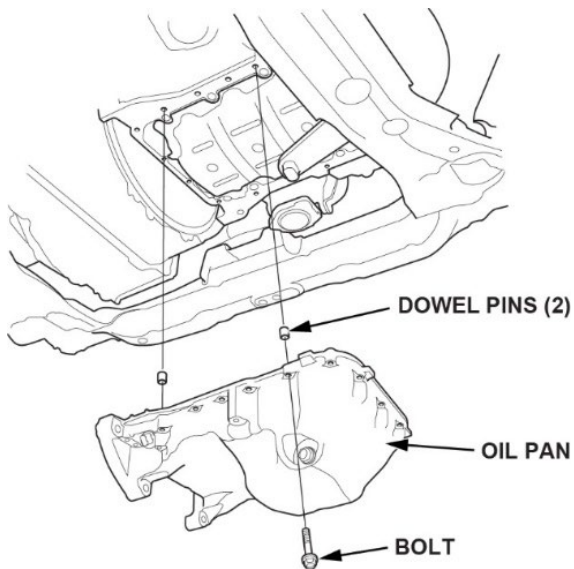

18. Tighten the bolts in **three steps**; tighten the bolts until the bolts sit on the oil pan, tighten the bolts until the gasket is compressed, torque the bolts to **12 N·m (9 lb-ft)**. Follow the sequence shown.

NOTE:

- Wait at least **30 minutes** before filling the engine with oil.
- Do not run the engine for at least **3 hours** after installing the oil pan.

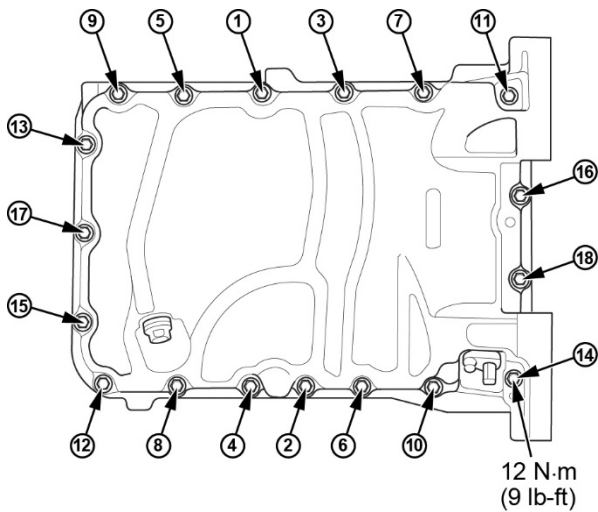

19. Install the lower transmission assembly mounting bolts and torque to **75 N·m (55 lb-ft)**, then install the torque converter cover and torque to **12 N·m (9 lb-ft)**.

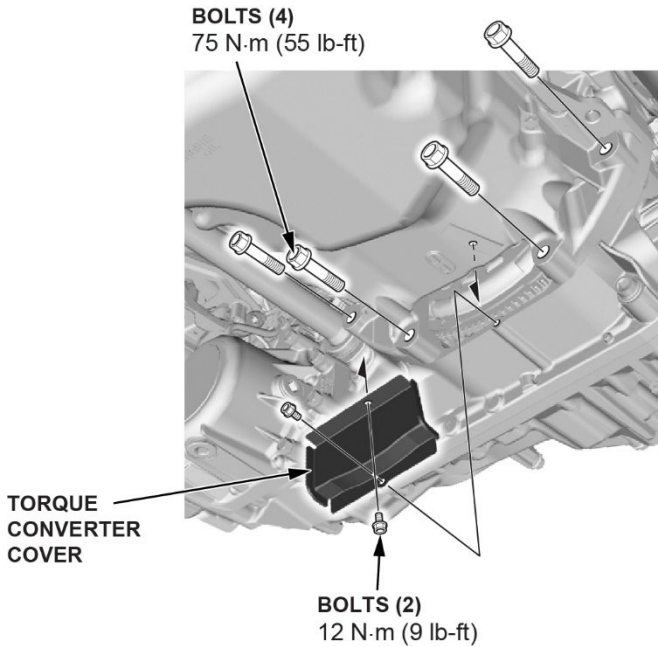

20. Reconnect the CKP sensor, then install the CKP sensor cover, **12 N·m (9 lb-ft)**.

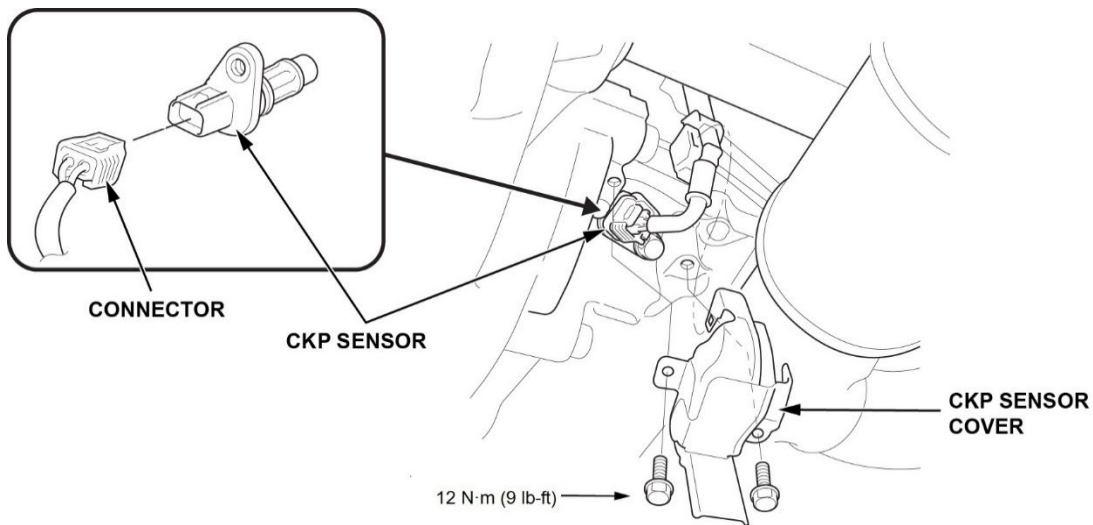

21. **INSPECTION B ONLY:** Install the A/C compressor bracket.

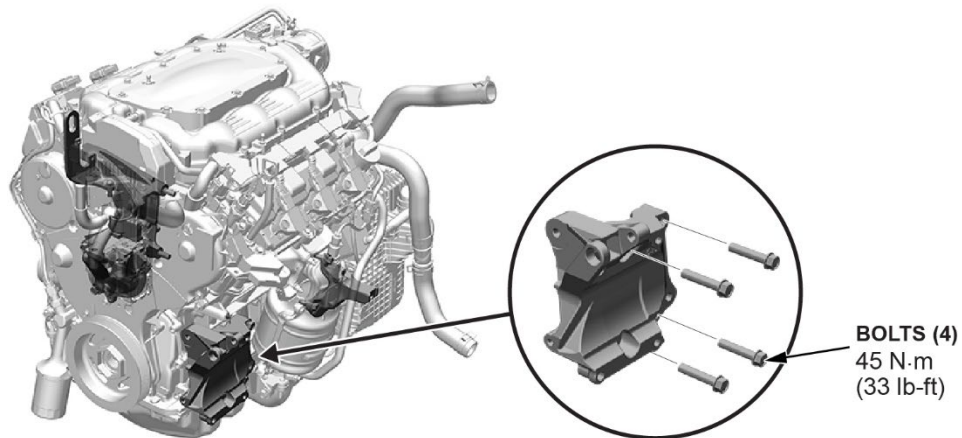

22. Lower the vehicle.

23. **INSPECTION B ONLY:** Install the A/C compressor with the upper mounting bolts.

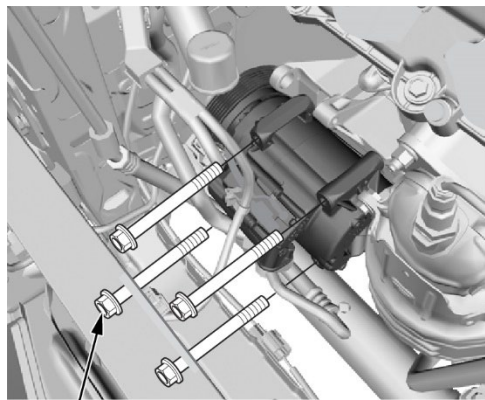

BOLTS (4)
22 N·m (16 lb-ft)

INSPECTION B ONLY: Remove the radiator shield.

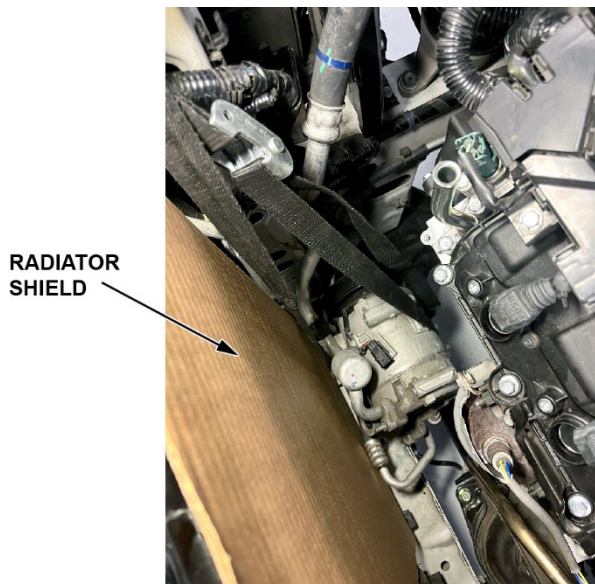

INSPECTION B ONLY: Install the alternator. Install the alternator to the alternator bracket.

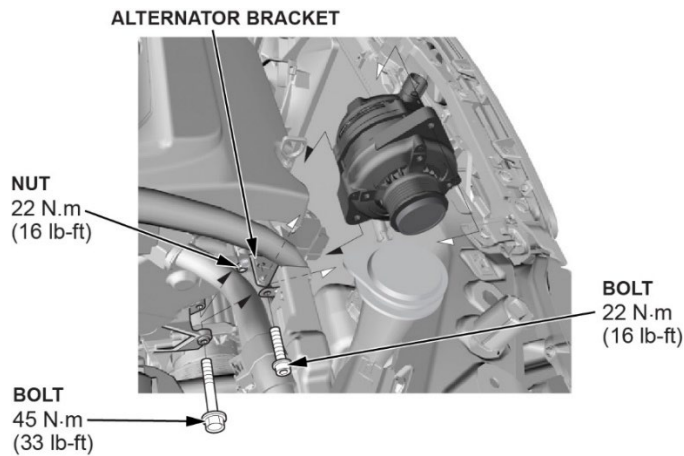

INSPECTION B ONLY: Connect the A/C compressor clutch connector, the alternator connector, and the positive alternator cable. Then install the harness clamp and bolt.

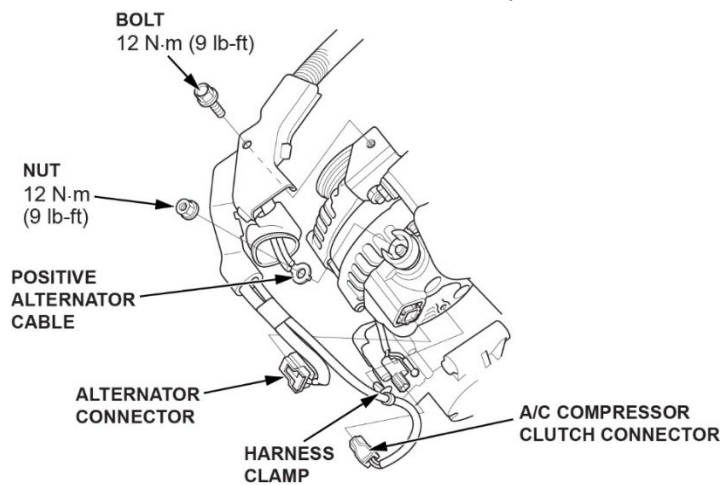

24. **INSPECTION B ONLY:** Install the condenser fan and reconnect the wiring.

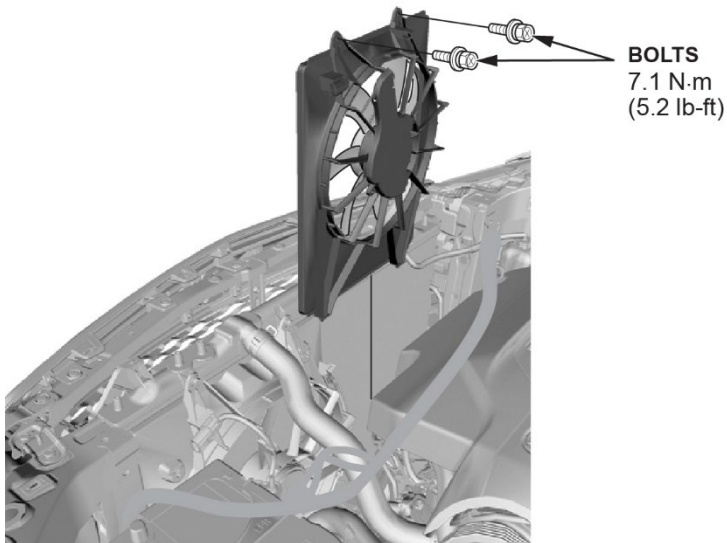

25. **INSPECTION B ONLY:** Install the passenger's side bulkhead brace and upper bolt.

LOOKING DOWN FROM UNDER HOOD

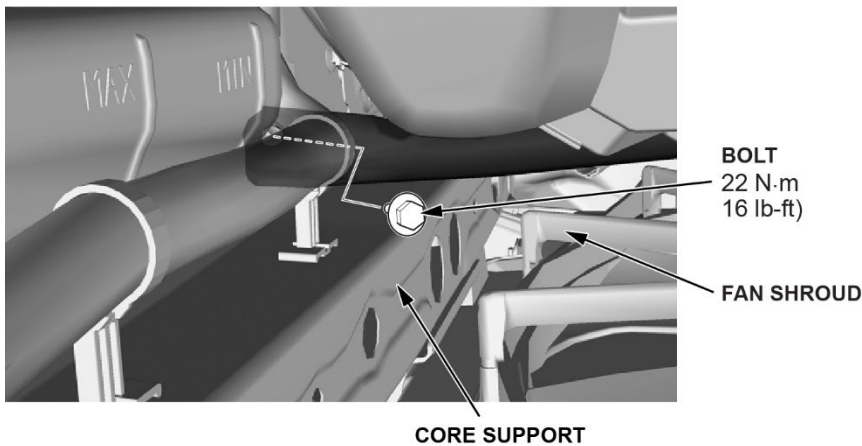

26. **INSPECTION B ONLY:** Install the bulkhead.

14 – 16 MY SHOWN

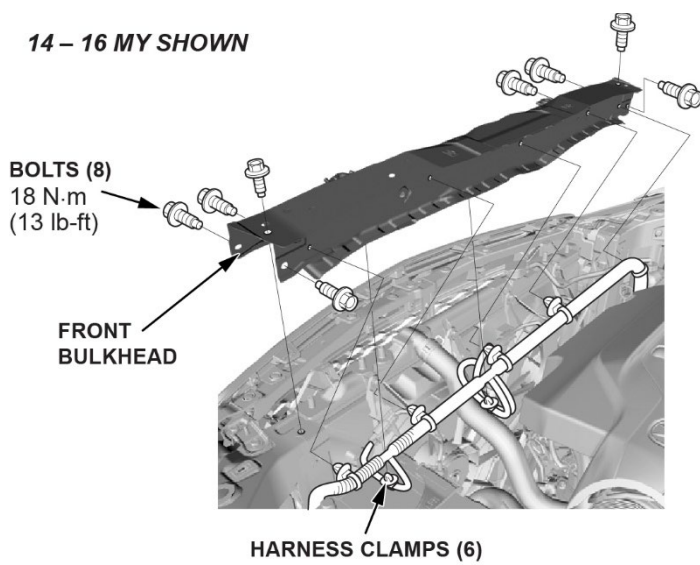

27. Raise the vehicle.
28. Install the under-floor TWC (A-pipe).

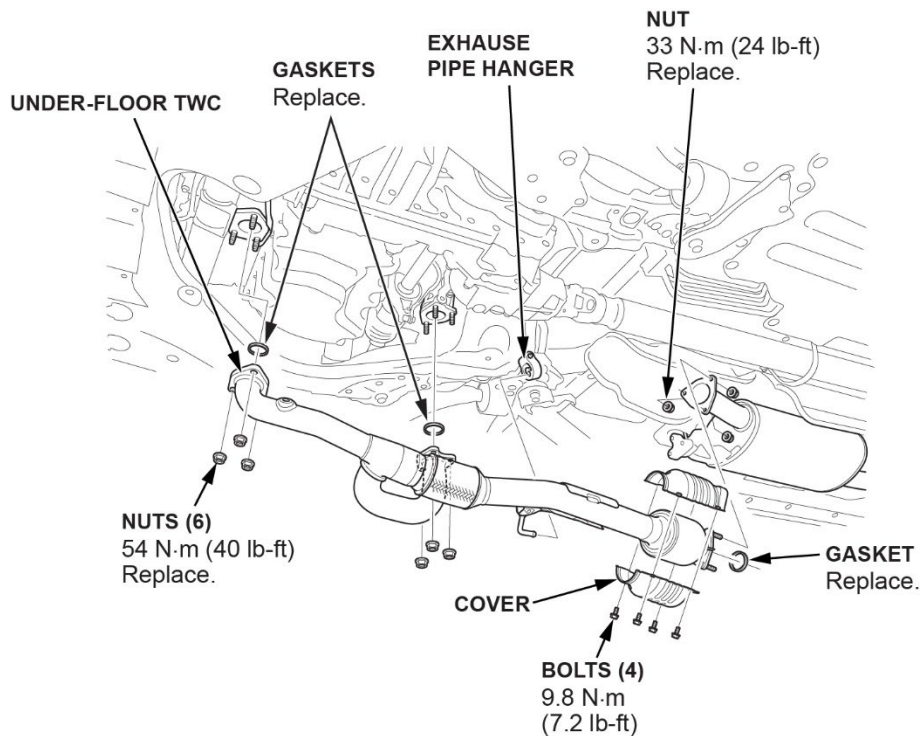

29. Install the subframe stiffener plate.
- NOTE:** Bolts are a must replace part.

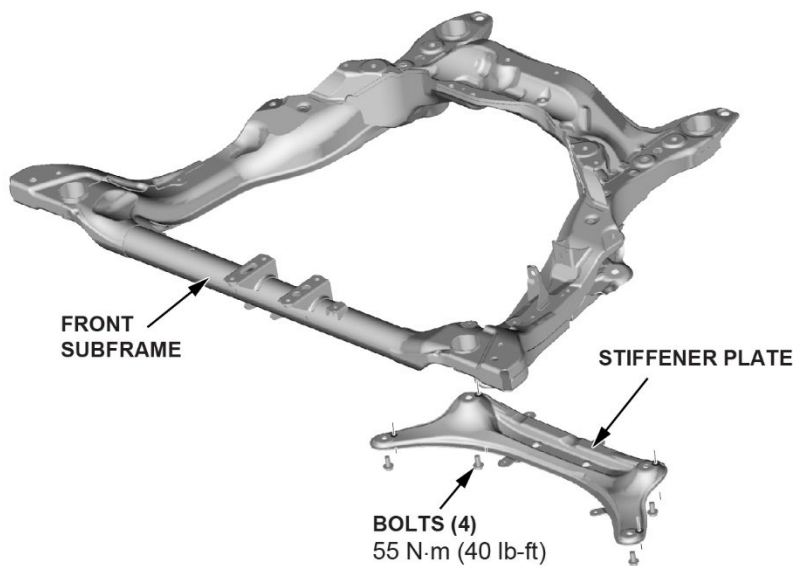

30. Reconnect the bank 2 oxygen sensor.

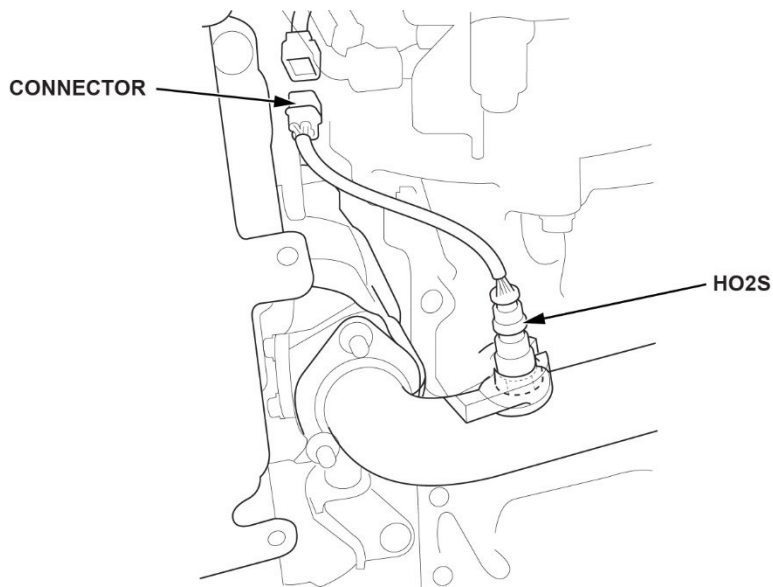

31. Install the passenger side fender liner.

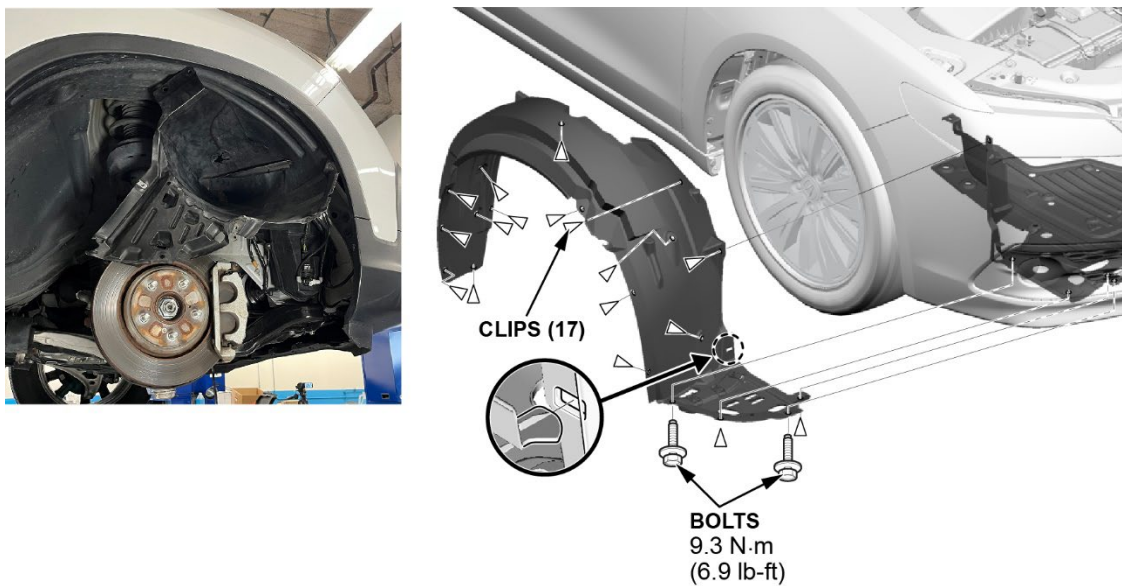

32. **INSPECTION B ONLY:** Install the bulkhead brace lower bolt.

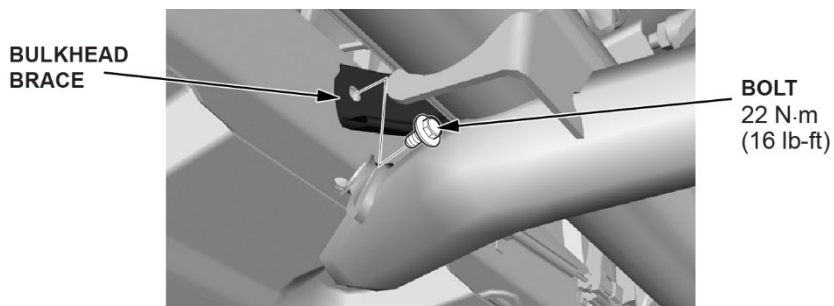

33. **INSPECTION B ONLY:** Install the lower A/C Compressor bolts and torque to **22 N·m (16lb-ft)**.

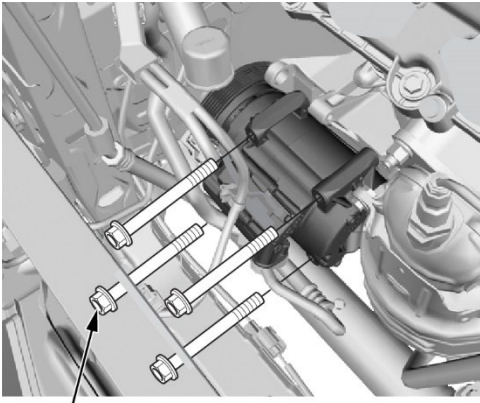

BOLTS (4)
22 N·m (16 lb-ft)

34. **INSPECTION B ONLY:** Install the passenger's side driveshaft.

1. Apply **2.0-3.0 g** of molybdenum grease to the whole splines surface of the right driveshaft.
2. After applying grease, remove the grease from the splined grooves at intervals of **2-3 splines** and from the set ring groove so that air can bleed from the intermediate shaft.
3. Install a new set ring.
4. Insert the inboard joint end of the driveshaft onto the intermediate shaft until the set ring locks in the groove.

NOTE: Insert the driveshaft horizontally to avoid damaging the oil seal.

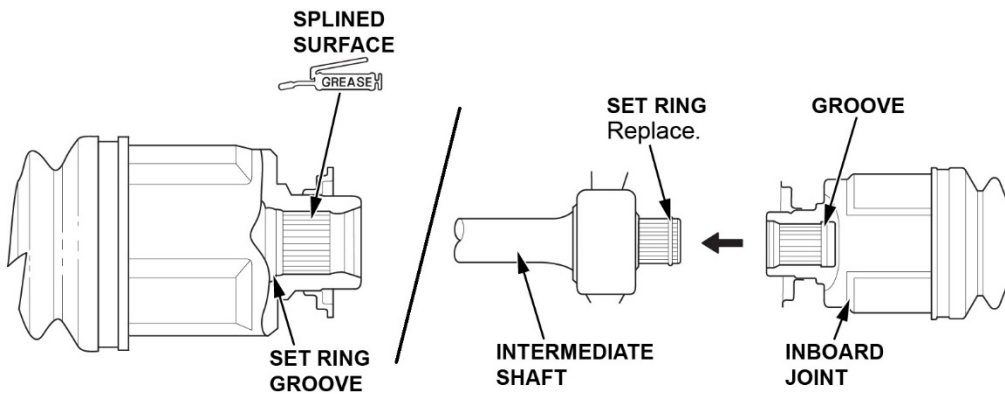

5. Apply about 3.0 g of molybdenum grease to the contact area of the outboard joint and the front wheel bearing.
6. Install the outboard joint into the front hub on the knuckle.

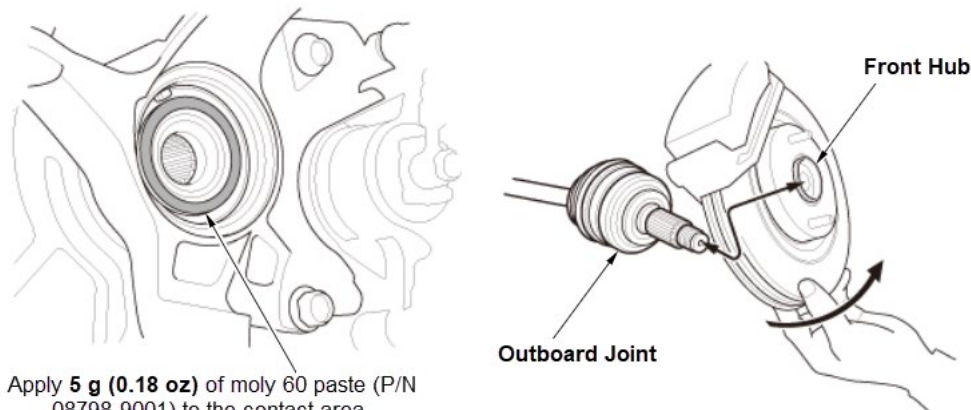

7. Install the new spindle nut.

- Apply a small amount of engine oil to the seating surface of the new spindle nut.
- Use a drift to stake the spindle nut shoulder against the driveshaft.
- Be careful not to make a crack on the spindle nut when staking.

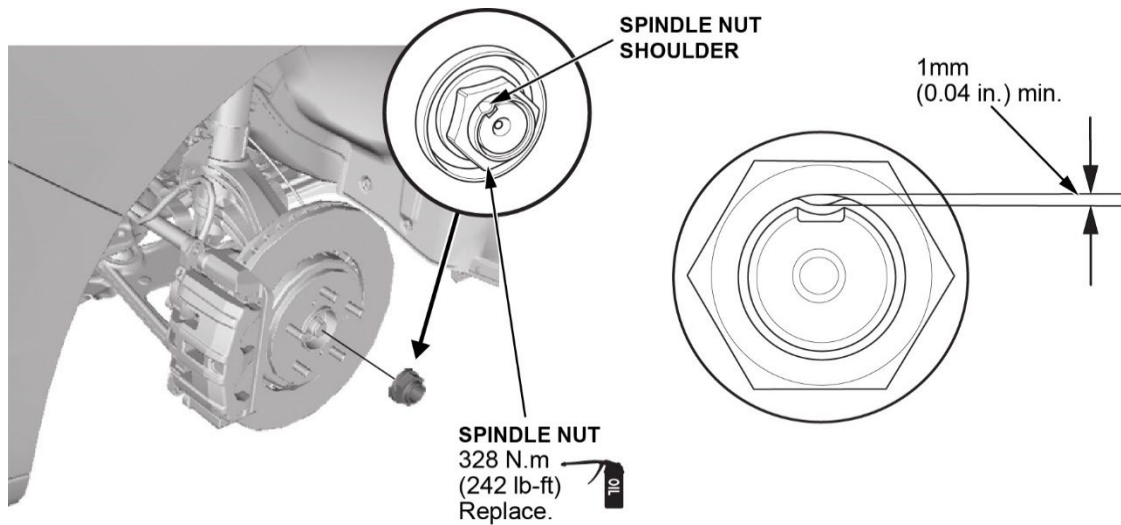

35. Connect the passenger's side lower knuckle ball joint.

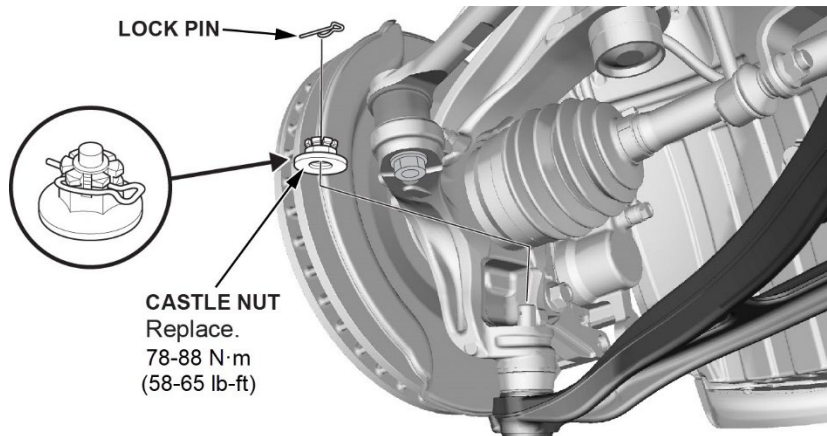

36. Connect the passenger's side tie rod ball joint.

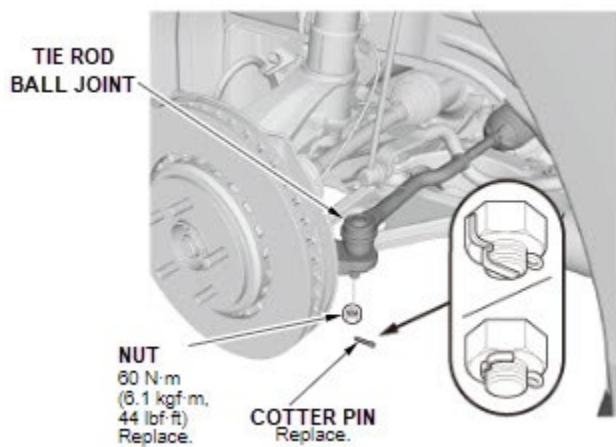

37. **INSPECTION B ONLY:** Install the drive belt.

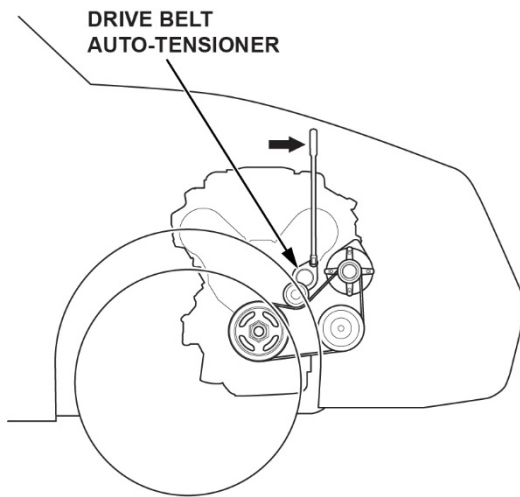

38. Install the passenger's side front wheel.

NOTE: For **2016 MDX**-torque wheel nuts to **108 N·m (80 lb-ft)**, for **2017-2020 MDX**- torque wheel nuts to **127 N·m (94 lb-ft)**.

39. Install the engine undercover.

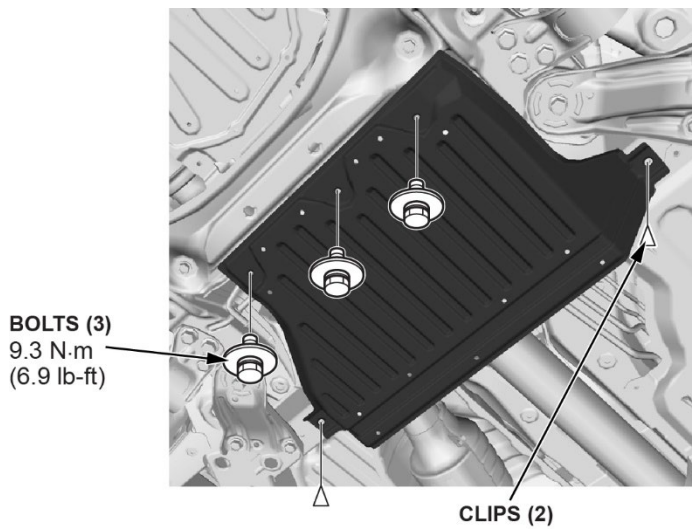

40. Install the splash shield.

41. Install the oil pan drain plug with new washer and torque to **40 N·m (30 lb-ft)**.

42. Lower the vehicle.

43. Install the spark plugs.

FRONT

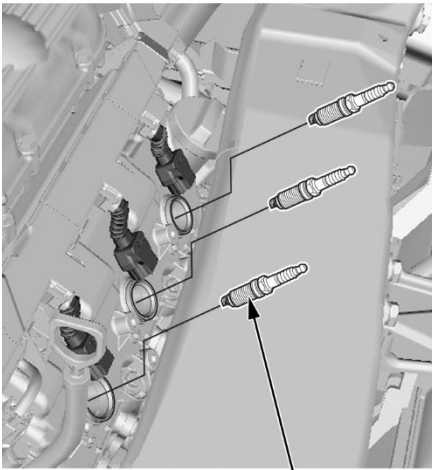

SPARK PLUGS
22 N·m (16 lb-ft)

REAR

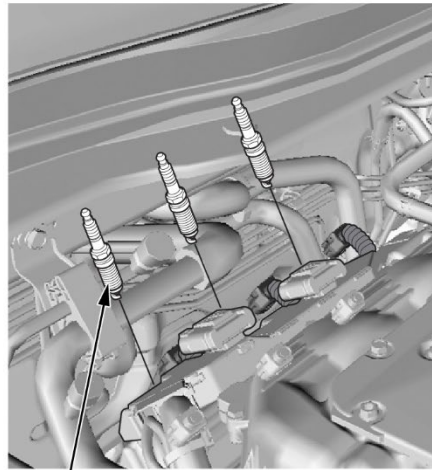

SPARK PLUGS
22 N·m (16 lb-ft)

44. Install and connect the coil packs.

FRONT

CONNECTOR

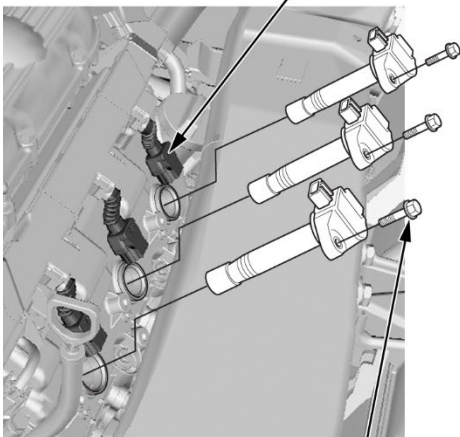

BOLTS
12 N·m
(9 lb-ft)

REAR

CONNECTOR

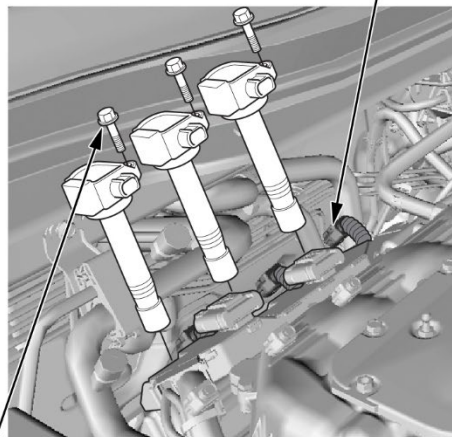

BOLTS
12 N·m
(9 lb-ft)

45. Install the oil dipstick.

46. Refill the engine with recommended engine oil.

Capacity

At Oil Change – 5.1L (5.4 US qt)

47. Connect the 12-volt battery.

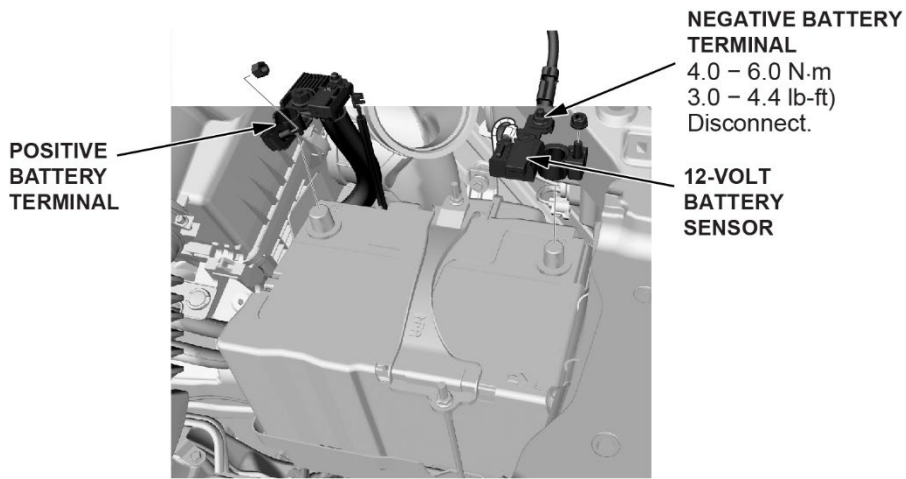

48. Install the air intake tube.

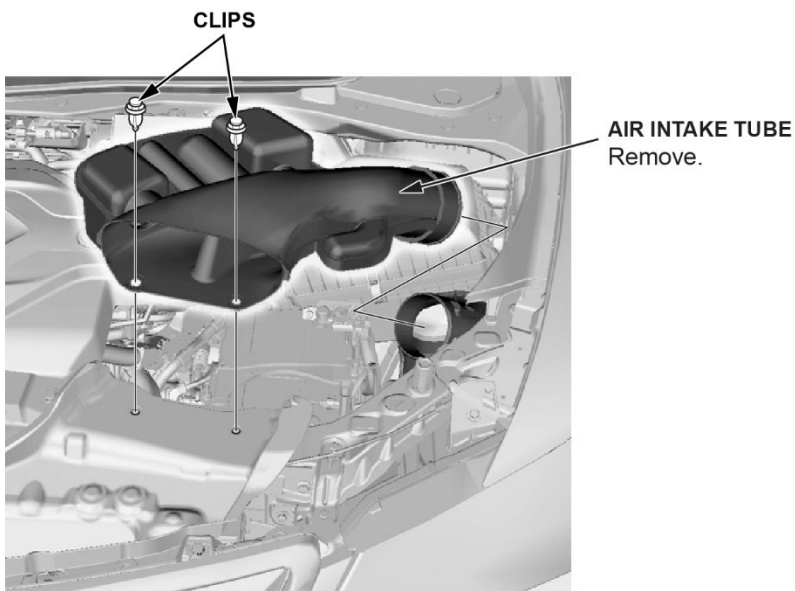

49. Install the front bulkhead cover.

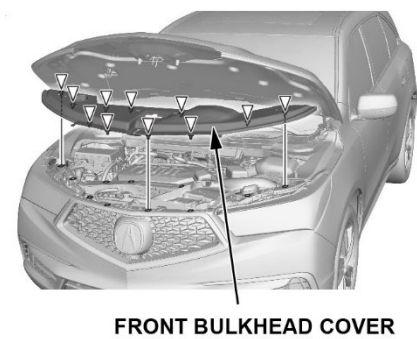

50. Install the engine cover.

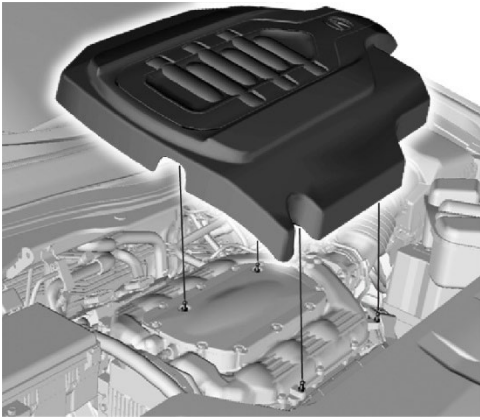

51. Make sure the vehicle has sat for at least **3 hours** from the time the oil pan was reinstalled.

Note: This is to make sure the sealant on the oil pan has completely cured.

52. Connect to the i-HDS.

53. Do a PCM reset.

1. Select the PGM-FI system with the i-HDS.
2. Reset the PCM with the i-HDS while the engine is stopped.
3. Turn the vehicle to the OFF (LOCK) mode.
4. Turn the vehicle to the ON mode and wait **30 seconds**.
5. Turn the vehicle to the OFF (LOCK) mode and disconnect the i-HDS from the DLC.

54. Do the CKP Pattern clear and learn.

1. Turn the vehicle to ON mode, but do not start the engine.
2. Connect the i-HDS to the DLC located under the driver's side of the dashboard.
3. Select CRANK PATTERN in the ADJUSTMENT MENU with the i-HDS.
4. Select CRANK PATTERN CLEAR with the i-HDS and clear the CKP pattern.
5. Select CRANK PATTERN LEARNING with the i-HDS and follow the screen prompts.
6. Turn the vehicle to the OFF (LOCK) mode.
7. Jump the SCS line with the i-HDS.
8. Wait **60 seconds** and exit the SCS mode with the i-HDS.

55. Do the Idle Speed Inspection.

NOTE: If the idle speed is not within specification, do the *PCM Idle Learn Procedure* in the service manual.

1. Start the engine and place the vehicle in PARK or NEUTRAL.
2. Hold the engine speed **without load** at **3,000 rpm** until the radiator fan comes on, then let it idle.
3. Check the idle speed under no load conditions: headlights, blower fan, radiator fan, audio system, and A/C off.

Idle Speed at No Load Should Be:

Engine: 680 ± 50 rpm in PARK or NEUTRAL

4. Let the engine idle for 1 minute with a high electrical load (A/C on, temperature set to max cool, blower fan on high, headlights on high beam).

Idle speed at High Load Should Be:

Engine: 680 ± 50 rpm in PARK or NEUTRAL

56. Do the VSA Sensor Neutral Position Memorization procedure.

NOTE: Do not press the brake pedal during this procedure.

1. Park the vehicle on a flat and level surface.
2. Make sure the steering wheel is straight ahead.
3. Select **VSA ADJUSTMENT** in the i-HDS.
4. Select **ALL SENSORS** and follow the screen prompts.

57. Do the Steering Angle Sensor Neutral Position.

1. Select **EPS ADJUSTMENT** on the i-HDS.
2. Select **EPS STEERING ANGLE SENSOR VALUE CLEAR** and follow the screen prompts.

58. Exit the i-HDS, **REPAIR #1** is complete.

REPAIR #2 LONG BLOCK REPLACEMENT

NOTE:

- Log into the application tool prior to starting this portion and input any necessary photo(s) for the new parts. For BEARING INSPECTION application instruction, refer to this Job Aid: [\(Click HERE\)](#)
 - The Bearing Inspection Inquiry Team will email unique warranty codes to file a claim.
1. Remove the steering joint cover, then disconnect the steering joint from the pinion shaft.
NOTE: *Steering Gearbox Removal and Installation* [\(Click Here\)](#)
 2. Remove the passenger's side center console side cover.
NOTE: *Center Console Side Cover Removal and Installation* [\(Click Here\)](#)
 3. Disconnect the 2 EPS connectors from the passenger side footwell in front of center console. Push the harness through the firewall. Pull the harness zip tie from body bolt.
NOTE: Step 12, *Engine Removal and Installation* [\(Click Here\)](#)
 4. Remove the front bulkhead cover.
NOTE: *Front Bulkhead Cover Removal and Installation* [\(Click Here\)](#)
 5. Remove the air intake tube and air cleaner box.
NOTE: *Air Cleaner Removal and Installation* [\(Click Here\)](#)
 6. Disconnect the negative 12-volt battery cable, then disconnect the positive battery cable.
NOTE: *Battery Terminal Disconnection and Reconnection* [\(Click Here\)](#)
 7. Disconnect the battery vent blower connector, then remove the 12-volt battery.
NOTE: *Battery Removal and Installation* [\(Click Here\)](#)
 8. Disconnect the EVAP cannister purge hose and the brake booster vacuum hose.
NOTE: Steps 9-10, *Engine Removal and Installation* [\(Click Here\)](#)
 9. Disconnect the PCM and engine wire harness connectors.
NOTE: *Engine Removal and Installation* [\(Click Here\)](#)
 10. Lift the vehicle.
 11. Remove the front wheels.
NOTE: For **2016 MDX**-torque wheel nuts to **108 N·m (80 lb-ft)**, for **2017-2020 MDX**- torque wheel nuts to **127 N·m (94 lb-ft)**.
 12. Move the driver's side fender liner as needed.
 13. **(SH-AWD)** Unbolt the propeller shaft from the transfer case.
NOTE:
 - Make a reference mark across the propeller shaft and transfer case flanges.
 - *Propeller Shaft Removal and Installation* [\(Click Here\)](#)

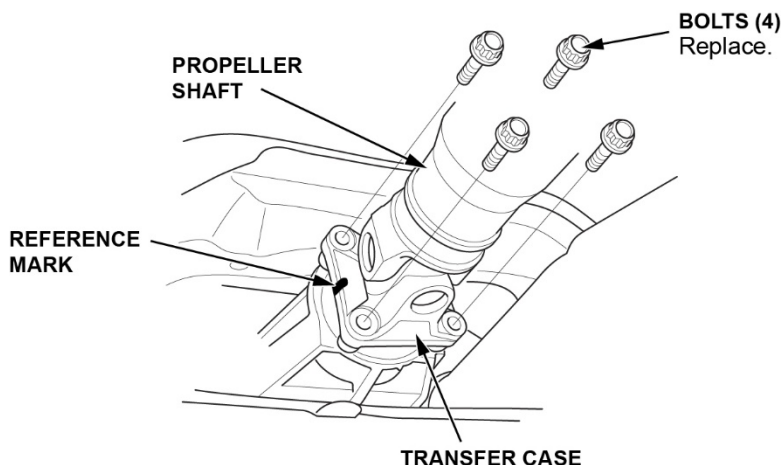

14. Drain the coolant.
NOTE: *Coolant Replacement* ([Click Here](#))

15. **If not removed during inspection B**, separate the passenger side axle joint from the intermediate shaft.

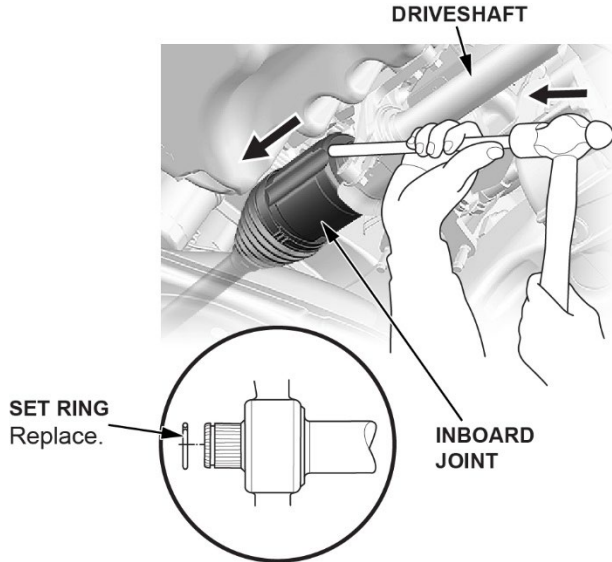

16. Remove the transmission ground cable.
NOTE: Step 36, *Automatic Transmission Removal and Installation* ([Click Here](#))
17. Disconnect the front engine mount actuator connector.
NOTE: See step 33, *Automatic Transmission Removal and Installation* ([Click Here](#))
18. Disconnect the rear engine mount actuator connector.
NOTE: Step 2, *Rear Engine Mount Removal and Installation* ([Click Here](#))
19. Remove the torque converter bolts.
NOTE: Step 37, *Automatic Transmission Removal and Installation* ([Click Here](#))
20. Disconnect the upper stabilizer link mounting point (both sides).
NOTE: Step 3, *Front Stabilizer Link Removal and Installation* ([Click Here](#))
21. Remove the lower bolts to the core support brace.
22. Remove the lower bulkhead brace bolts.
NOTE: Step 2-Right Side, *Front Bulkhead Brace Removal and Installation* ([Click Here](#))
23. Lower the vehicle.
24. Remove the upper bulkhead (Do not remove the front bumper center upper beam).
NOTE: **Step 5 only**, *Radiator and A/C Condenser Fan, Motor, and Shroud Removal and Installation* ([Click Here](#))
25. Disconnect the upper and lower radiator hoses from the engine.
26. Disconnect the ATF warmer lower hoses on engine side.
NOTE: Step 10, *ATF Warmer Removal and Installation* ([Click Here](#))
27. **If not removed during inspection B**, remove the passenger side bulkhead brace.
NOTE: *Front Bulkhead Brace Removal and Installation* ([Click Here](#))
28. **If not removed during inspection B**, disconnect the A/C condenser fan, then remove the condenser fan shroud assembly.
NOTE: *Radiator and A/C Condenser Fan, Motor, and Shroud Removal and Installation* ([Click Here](#))
29. **If not removed during inspection B**, remove the accessory drive belt.
NOTE: *Drive Belt Removal and Installation* ([Click Here](#))
30. **If not removed during inspection B**, Disconnect and remove the alternator.
NOTE: *Alternator Removal and Installation* ([Click Here](#))

31. If not removed during inspection B, unbolt the A/C compressor and move forward to sit on core support.



SECURED
COMPRESSOR

32. Disconnect the heater hoses from the engine.

NOTE *Water Passage Removal and Installation* ([Click Here](#))

33. Disconnect the quick connect style ATF cooler lines (if equipped).

- Remove the bolt and bracket.
- Push the retaining clip out, then detach the cooler lines.

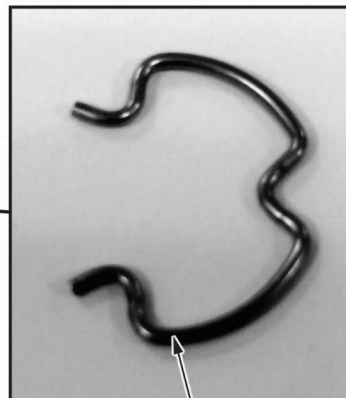
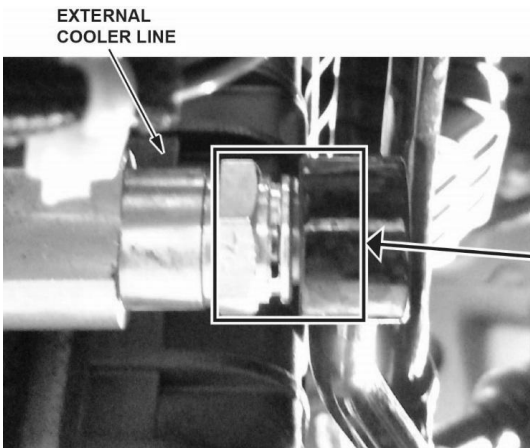
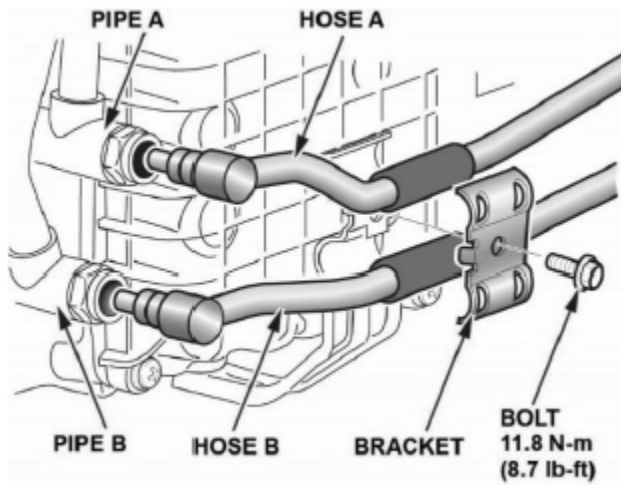

RETAINING CLIP

34. Unbolt the side engine mount bracket.

NOTE: *Side Engine Mount Removal and Installation* ([Click Here](#))

35. Disconnect the fuel line at the high-pressure fuel pump.

NOTE: *Fuel Line/Quick-Connect fitting Removal and Installation* ([Click Here](#))

36. Raise the vehicle to waist height.

37. If the passenger side tie rod ball joint and lower knuckle ball joint were separated for the main cap inspection:

- Reinstall the lower knuckle ball joint with a new castle nut. Torque to specification then install the lock pin.

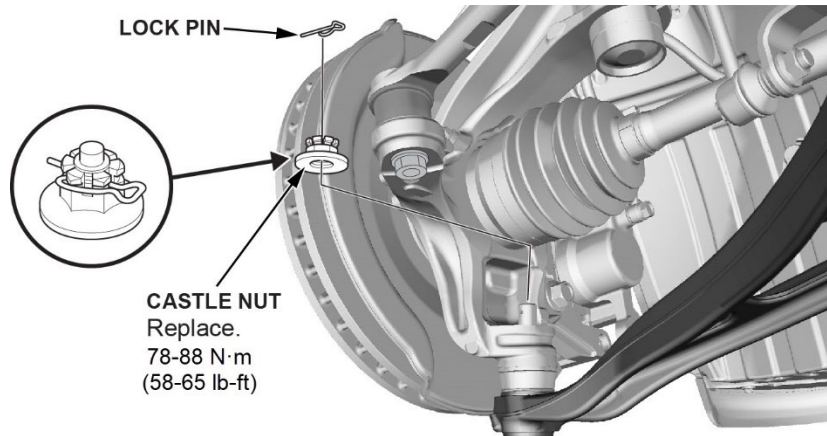

- Reinstall the tie rod ball joint with a new nut. Torque to specification then install a new cotter pin.

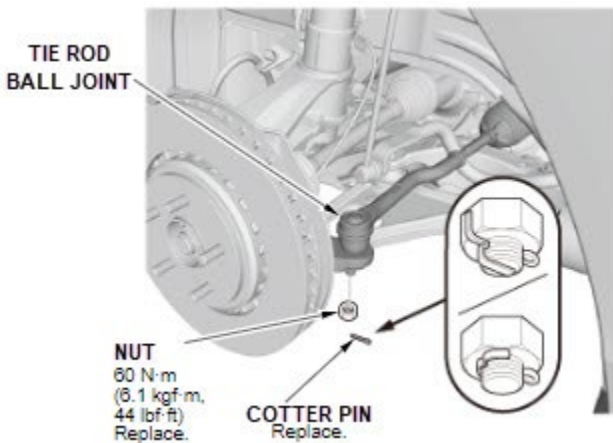

38. Remove the pinch bolt for the knuckle and strut (both sides).

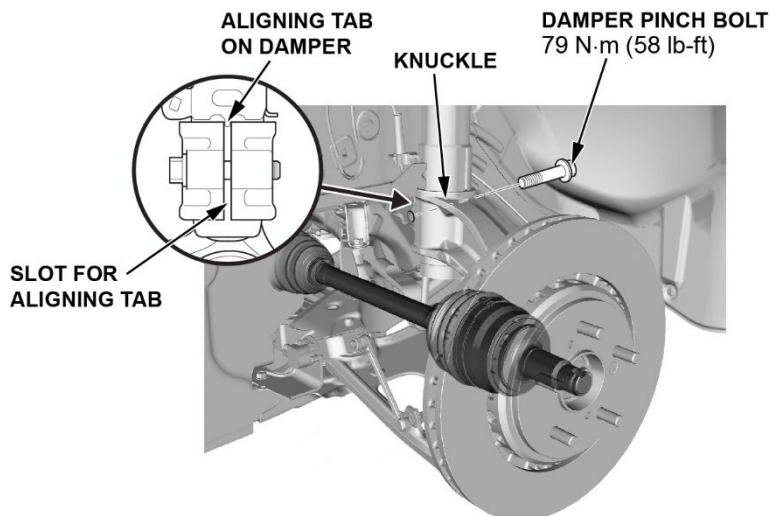

39. Leaving the hydraulic brake line attached, unbolt the brake caliper at the bracket and hang it on the spring with an S-hook (both sides).

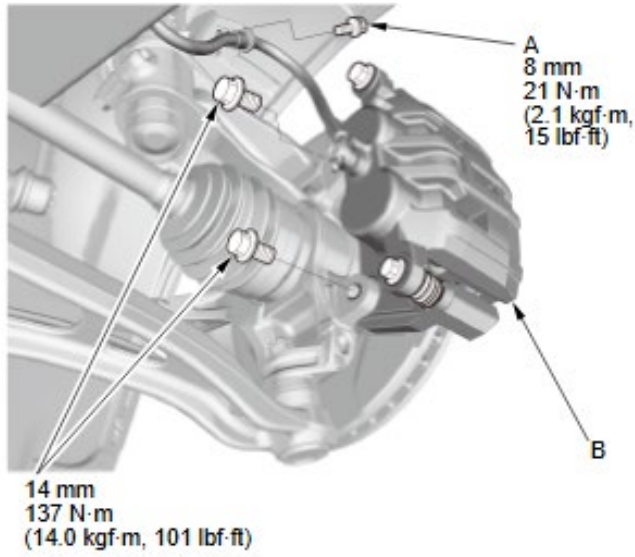

40. Remove the wheel speed sensor from the knuckle and secure it so it is not hanging loose.

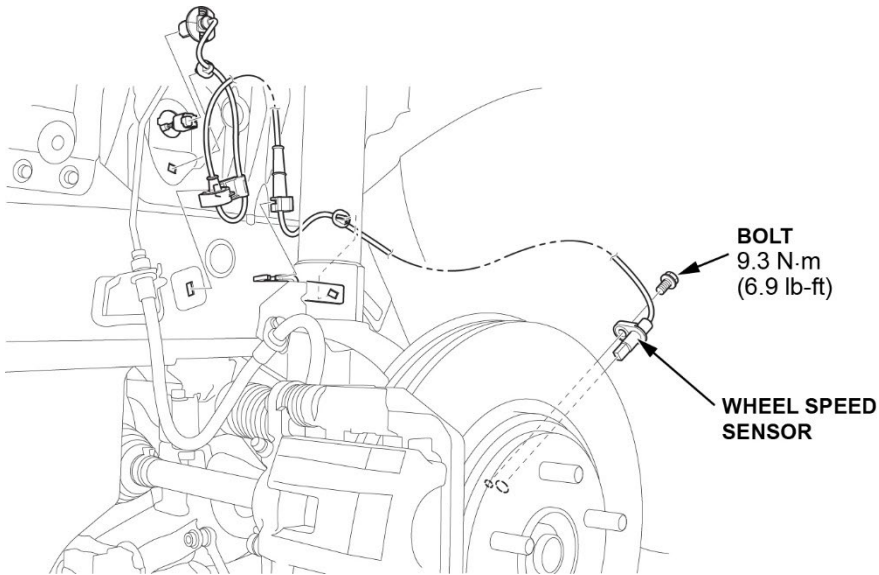

41. Set the lift table under the subframe with the subframe attachment.
NOTE: Use the integrated strap to aid in securing the subframe and posts.

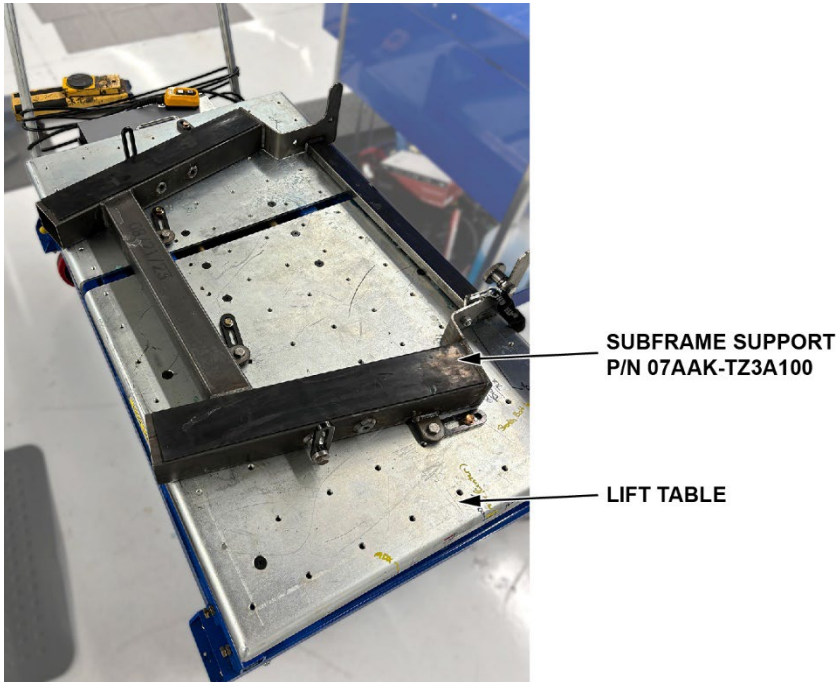

42. Raise the lift table until it contacts the subframe.
43. Unbolt the front subframe.
Note: *Subframe Removal and Installation* ([Click Here](#))
44. Lower the lift table with the subframe, engine, front knuckles, and transmission assemblies.
NOTE: Lower table and/or raise vehicle to clear the powertrain from the chassis.

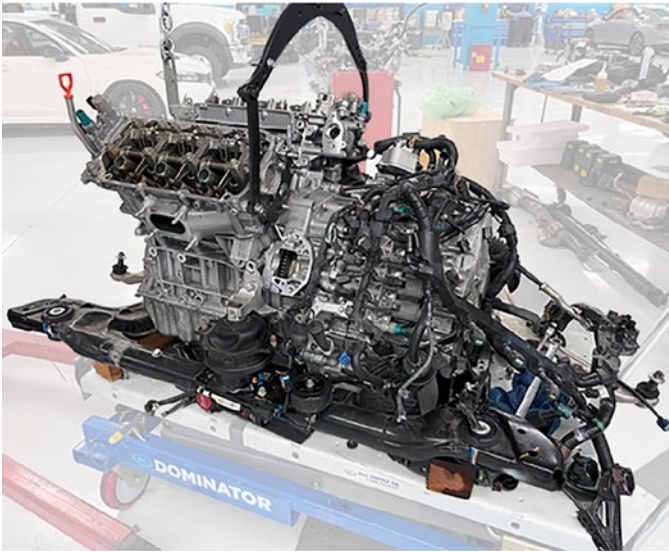

45. **If not removed during inspection B**, remove the passenger's side driveshaft spindle nut, then remove the driveshaft.
NOTE: *Front Driveshaft Removal and Installation* ([Click Here](#))
46. Disconnect the bank 1 oxygen sensors, then remove the front and rear catalytic convertors.
NOTE: *Warm Up TWC Removal and Installation* ([Click Here](#))

47. Remove the intermediate shaft, then insert the transmission axle cap.

NOTE: *Intermediate Shaft Removal and Installation* ([Click Here](#))



9AT TRANSMISSION CAP
(CAP, 9 AT PROTECTING)
P/N 07AAK-514A101

48. Mount the **new long block assembly** to the engine stand.

49. Apply painter's tape to the intake ports.

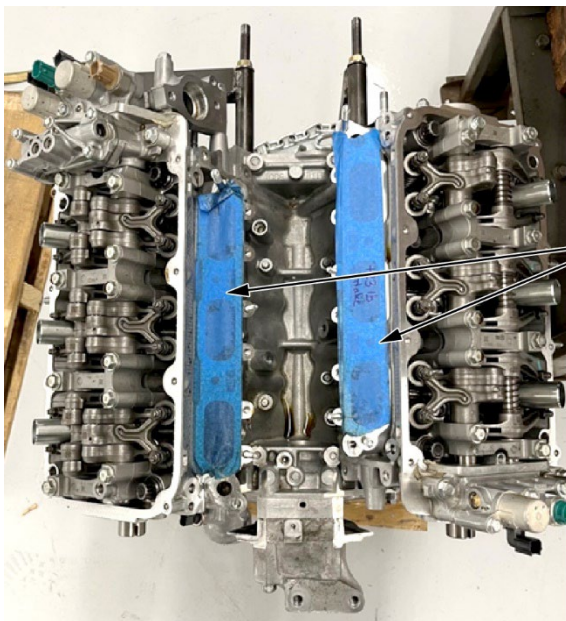

PAINTERS TAPE
Apply tape to the
intake ports.

50. Transfer the A/C compressor bracket to the new engine.

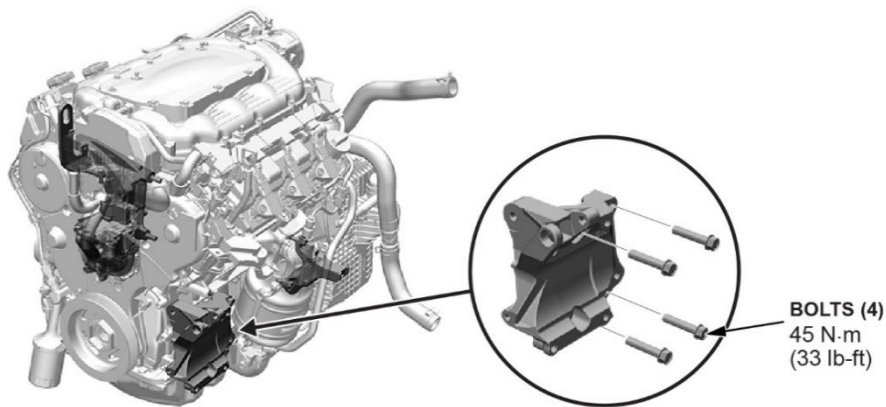

51. Remove the front engine mount stops.
NOTE: Steps 4-5, *Front Engine Mount Removal and Installation* ([Click Here](#))
52. Remove the intake manifold and intake manifold base.
NOTE: Steps 7-9, *Intake Manifold Removal and Installation* ([Click Here](#))
53. Transfer the bank 2 heat shield at the valve cover to the new engine.
54. Transfer the timing belt guide plate.
NOTE: *Timing Belt Removal and Installation* ([Click Here](#))
55. Transfer the crankshaft pulley and torque to **65 N·m (48 lb-ft), then an additional 60°**.
56. Transfer the CKP sensor with a new O-ring.
NOTE: *CKP Sensor Removal and Installation* ([Click Here](#))
57. Unbolt and disconnect the ICM.
NOTE: *Injector Control Module Removal and Installation* ([Click Here](#))
58. Disconnect the fuel rail connectors behind the ICM.
59. Remove the high-pressure fuel pump cover and injector cover.
NOTE: *High Pressure Fuel Pump Removal and Installation* ([Click Here](#))
60. Unplug the high-pressure fuel pump coupler.
61. Remove high-pressure fuel pump and roller.
62. Remove the fuel joint pipe.
63. Remove the fuel injector rails with the fuel injectors still attached.
NOTE: *Injector Removal and Installation* ([Click Here](#))
64. Remove the water passage off the original engine.
65. Remove the EVAP canister purge joint (do not reuse).
66. Unplug the camshaft position sensor on the rear cylinder head.
67. Remove the rubber insulator from the top of the right engine mount bracket.
68. Transfer the knock sensors and sub-harness to the new engine.
NOTE:
- Must be done BEFORE injectors and fuel rails are installed.
 - Coolant crossover pipe may need to be removed in order to secure the sub-harness to the new block.
 - *Knock Sensor Removal and Installation* ([Click Here](#))
69. Transfer the front valve cover breather vent hose.
70. Transfer the rear valve cover breather.
71. Transfer the ignition coils.
72. Transfer the engine wiring harness.
73. Install new fuel injector seals.
NOTE: Step 1, *Injector Removal and Installation* ([Click Here](#))

74. Install the fuel rail/fuel injector assemblies with new seals.
NOTE: *Injector Removal and Installation* ([Click Here](#))
75. Install the ICM bracket.
NOTE: Step 16, *Cylinder Head Removal and Installation* ([Click Here](#))
76. Install the ICM and reconnect.
NOTE: *Injector Control Module Removal and Installation* ([Click Here](#))
77. Install the injector cover.
78. Install the oil dipstick and oil fill cap.
79. Install the ICM cover.
80. Secure the engine harness ground.
81. Install the high-pressure pump with roller and a new fuel joint pipe.
NOTE: *High Pressure Fuel Pump Removal and Installation* ([Click Here](#))
82. Install the high-pressure pump cover.
83. Install the intake manifold base, manifold, and cover with new gaskets.
NOTE: *Intake Manifold Removal and Installation* ([Click Here](#))
84. Connect the front bank breather tube to the intake manifold.
85. Connect the water passage to the throttle body.
86. Connect the EVAP vacuum hoses and harness connector.
NOTE: Place a support under the transmission that may have an adjustment like a commercially available jack.
87. Remove the skid plate, disconnect the starter harness, then remove the starter.
NOTE: *Starter Removal, Installation, and Performance Test* ([Click Here](#))
88. Install the engine hanger to the original engine. Bolt on the special tool engine hanger (VSC02C000019 with VSB02C000044) and the load lever to the original engine.
89. Lift the engine to take the weight off of the engine mounts.
90. Remove the rear engine mount bolt to bracket.
NOTE: Installation step 1, *Engine Removal and Installation* ([Click Here](#))
91. Remove the front engine mount and front engine mount bracket.
NOTE: Installation step 1, *Engine Removal and Installation* ([Click Here](#))
92. Support the transmission.
93. Separate the original engine from the transmission.
NOTE:
 - For ease of removal, pivot the engine assembly counterclockwise away from the EPS rack to separate the AT.
 - **Do not** lift the engine any higher after the front mount is removed.
94. Remove the drive plate.
95. Original engine is no longer needed from this point forward.
96. Install the engine hanger (VSB02C000019 with VSB02C000044) to the new long block.
97. Remove the new long block from the engine stand.
98. Install the drive plate.
NOTE: *Drive Plate Removal and Installation* ([Click Here](#))

99. Install the new engine to the transmission using the alignment pins (07AAG-5J4A100).

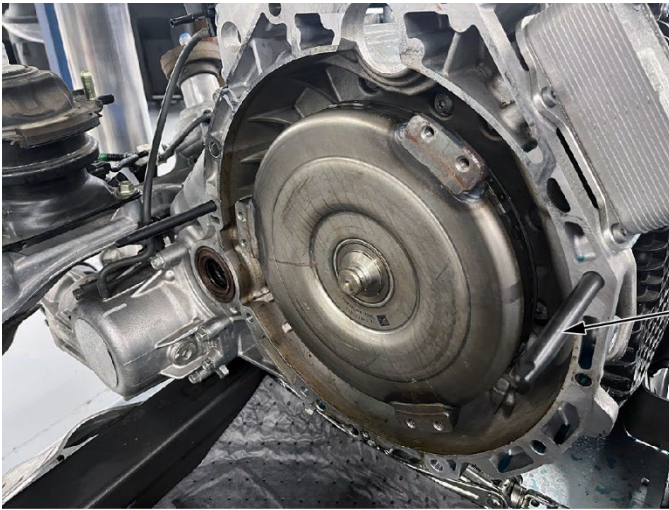

TRANSMISSION
ALIGN PIN
P/N 07AGG-5J4A100

100. Install the starter, starter harness, and skid plate.

NOTE: Starter Removal, Installation, and Performance Test ([Click Here](#))

101. Install the following:

NOTE: See above for appropriate hyperlinks.

1. Front engine mount bracket and mount
 2. Rear engine mount
 3. Front catalyst and EGR pipe
 4. Intermediate shaft and driveshaft
 5. Rear catalyst and engine mount heat shield
 6. Rear catalyst brace.
102. Log into the application and upload any necessary photos of the new long block, if not done so already.
103. Go to SUBFRAME INSTALLATION to continue with repair.

REPAIR #3 AND #4 CRANKSHAFT REPLACEMENT

NOTE:

- Log into the application tool prior to starting this portion and input any necessary photo(s) for the new parts.
For BEARING INSPECTION application instruction, refer to this Job Aid: [\(Click HERE\)](#)
- The remaining must-replace parts will not be shipped until the new crankshaft information is sent to the Bearing Inspection Inquiry Team.
- The Bearing Inspection Inquiry Team will email unique warranty codes to file a claim.

1. Remove the steering joint cover, then disconnect the steering joint from the pinion shaft.

NOTE: *Steering Gearbox Removal and Installation* [\(Click Here\)](#)

2. Remove the passenger's side center console side cover.

NOTE: *Center Console Side Cover Removal and Installation* [\(Click Here\)](#)

3. Disconnect the 2 EPS connectors from the passenger side footwell in front of center console. Push the harness through the firewall. Pull the harness zip tie from body bolt.

NOTE: *Engine Removal and Installation* [\(Click Here\)](#)

4. Remove the front bulkhead cover.

NOTE: *Front Bulkhead Cover Removal and Installation* [\(Click Here\)](#)

5. Remove the air intake tube and air cleaner box.

NOTE: *Air Cleaner Removal and Installation* [\(Click Here\)](#)

6. Disconnect the negative 12-volt battery cable, then disconnect the positive battery cable.

NOTE: *Battery Terminal Disconnection and Reconnection* [\(Click Here\)](#)

7. Disconnect the battery vent blower connector, then remove the 12-volt battery.

NOTE: *Battery Removal and Installation* [\(Click Here\)](#)

8. Disconnect the EVAP cannister purge hose and the brake booster vacuum hose.

NOTE: *Engine Removal and Installation* [\(Click Here\)](#). Steps 9 and 10.

9. Disconnect the PCM and engine wire harness connectors.

NOTE: *Engine Removal and Installation* [\(Click Here\)](#)

10. Lift the vehicle.

11. Remove the driver's side front wheels.

12. **(SH-AWD)** Unbolt the propeller shaft from the transfer case.

NOTE:

- Make a reference mark across the propeller shaft and transfer case flanges.
- *Propeller Shaft Removal and Installation* [\(Click Here\)](#)

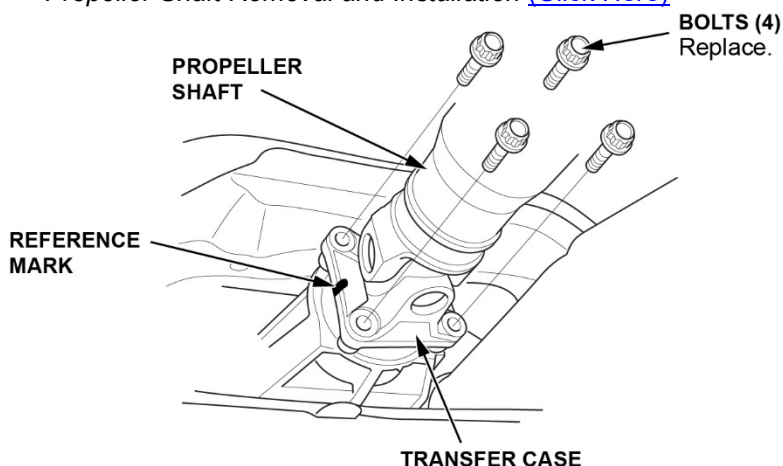

13. Drain the coolant.

NOTE: *Coolant Replacement* [\(Click Here\)](#)

14. Separate the passenger side driveshaft inner joint from the intermediate shaft.

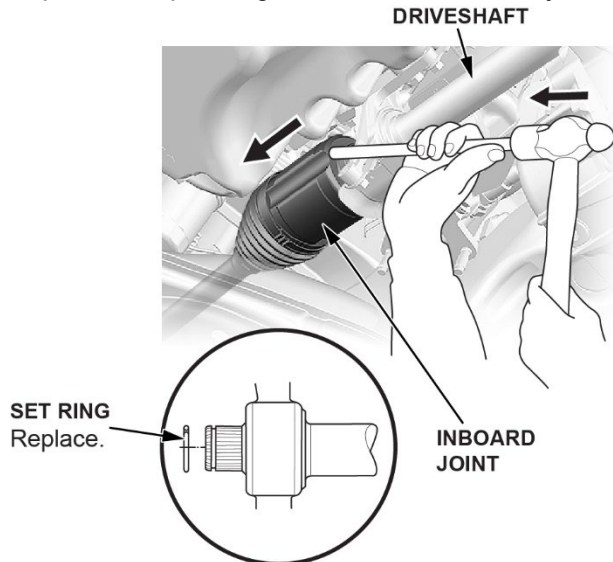

15. Remove the transmission ground cable.
NOTE: See step 36, *Automatic Transmission Removal and Installation* ([Click Here](#))
16. Disconnect the front engine mount actuator connector.
NOTE: See step 33, *Automatic Transmission Removal and Installation* ([Click Here](#))
17. Disconnect the rear engine mount actuator connector.
NOTE: *Rear Engine Mount Removal and Installation* ([Click Here](#))
18. Remove the torque converter bolts.
NOTE: *Automatic Transmission Removal and Installation* ([Click Here](#))
19. Disconnect the upper stabilizer link mounting point (both sides).
NOTE: *Front Stabilizer Link Removal and Installation* ([Click Here](#))
20. Remove the lower bolts to the core support brace.
21. Remove the lower bulkhead brace bolts.
NOTE: *Front Bulkhead Brace Removal and Installation* ([Click Here](#))
22. Lower the vehicle.
23. Remove the upper bulkhead (Do not remove the front bumper center upper beam).
NOTE: **Step 5 only**, *Radiator and A/C Condenser Fan, Motor, and Shroud Removal and Installation* ([Click Here](#))
24. Disconnect the upper and lower radiator hoses from the engine.
25. Disconnect the ATF warmer hoses on engine side.
NOTE: *ATF Warmer Removal and Installation* ([Click Here](#))
26. **If not removed during inspection B**, remove the passenger side bulkhead brace.
NOTE: *Front Bulkhead Brace Removal and Installation* ([Click Here](#))
27. **If not removed during inspection B**, disconnect the A/C condenser fan, then remove the condenser fan shroud assembly.
NOTE: *Radiator and A/C Condenser Fan, Motor, and Shroud Removal and Installation* ([Click Here](#))
28. **If not removed during inspection B**, remove the accessory drive belt.
NOTE: *Drive Belt Removal and Installation* ([Click Here](#))
29. Disconnect and remove the alternator.
NOTE: *Alternator Removal and Installation* ([Click Here](#))

30. If not removed during inspection B, unbolt A/C compressor and move forward to sit in core support.

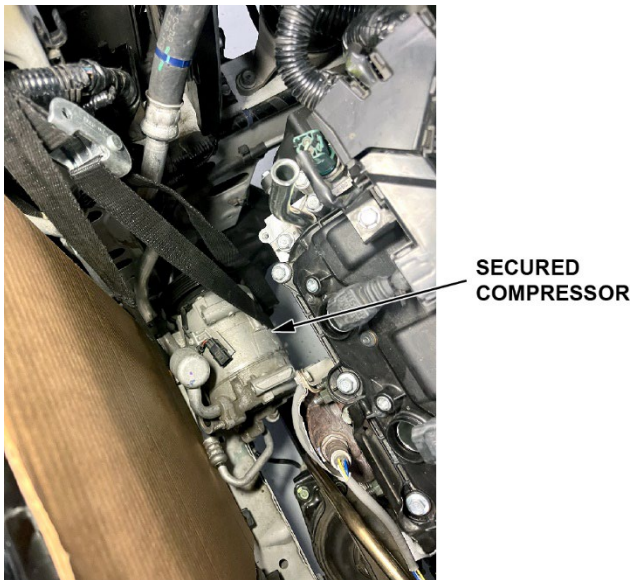

31. Disconnect the heater hoses from the engine.

NOTE *Water Passage Removal and Installation* ([Click Here](#))

32. Disconnect the quick connect style ATF cooler lines (with ATF Cooler).

- Remove the bolt and bracket.
- Push the retaining clip out, then detach the cooler lines.

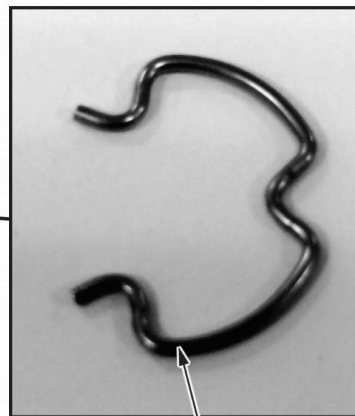
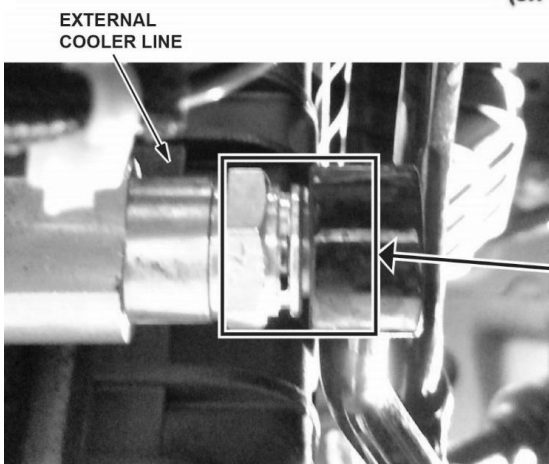
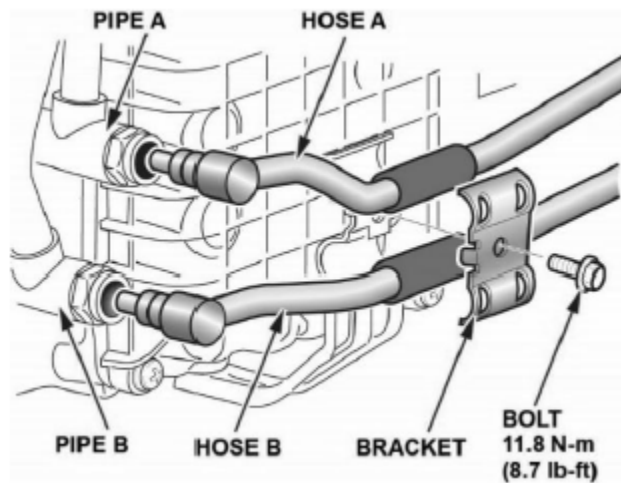

33. Unbolt side engine mount bracket.

NOTE: *Side Engine Mount Removal and Installation* ([Click Here](#))

34. Disconnect the fuel line at the high-pressure fuel pump.

NOTE: *Fuel Line/Quick-Connect fitting Removal and Installation* ([Click Here](#))

35. Raise the vehicle to waist height.

36. If the passenger side tie rod ball joint and lower knuckle ball joint were separated during inspection B:

- Reinstall the lower knuckle ball joint with a new castle nut. Torque to specification then install the lock pin.

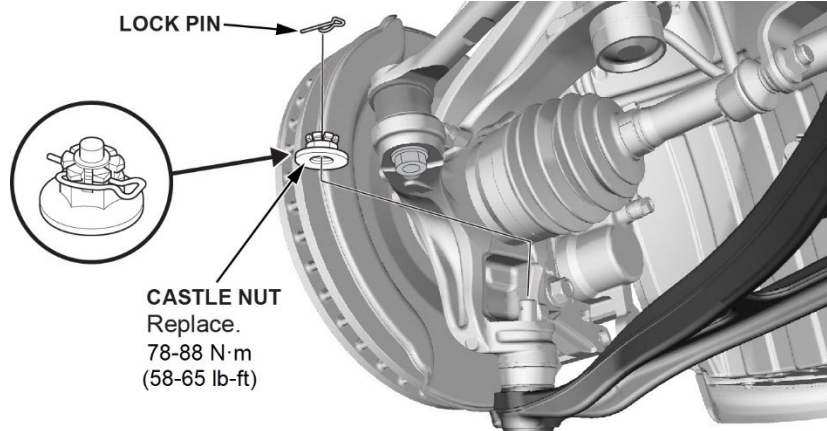

- Reinstall the tie rod ball joint with a new nut. Torque to specification then install a new cotter pin.

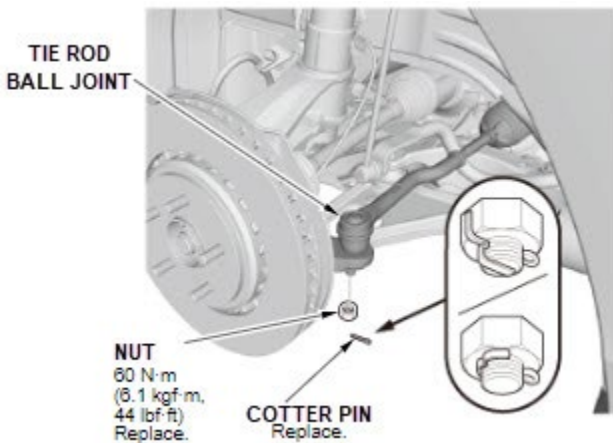

37. Remove the pinch bolt for the knuckle and strut (both sides).

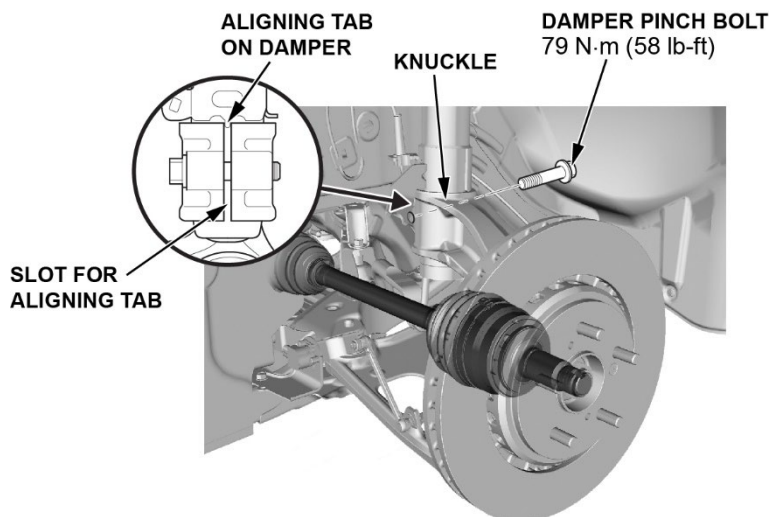

38. Leaving the hydraulic brake line attached, unbolt the brake caliper at the bracket and hang on the spring with an S-hook (both sides).

BOLTS
72 N·m (53 lb-ft)

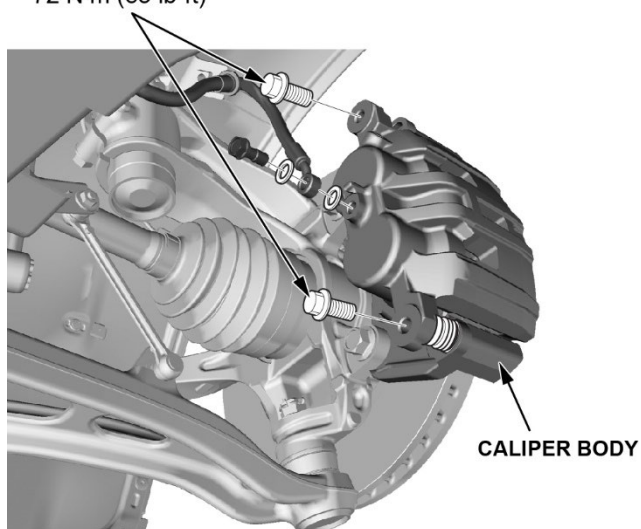

39. Remove the wheel speed sensor from the knuckle and secure it.

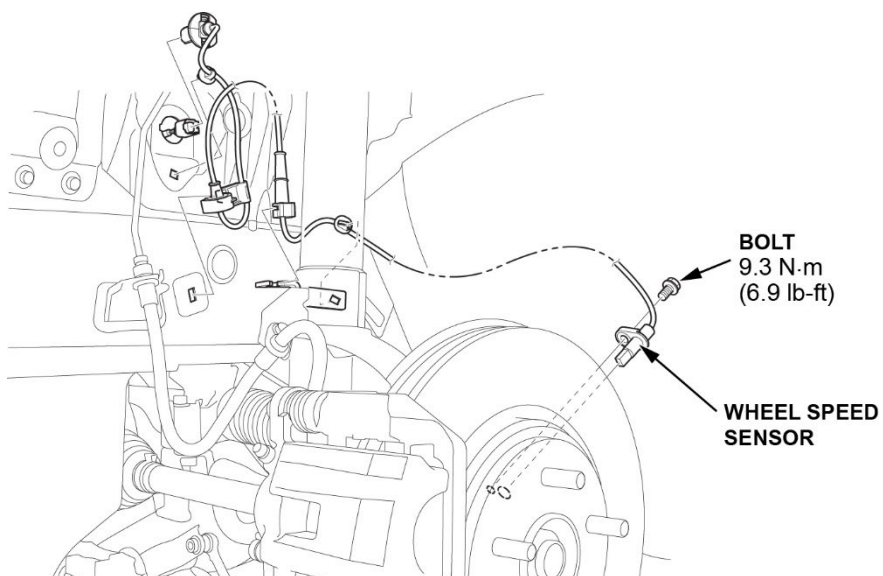

40. Set the lift table under the subframe with the subframe attachment.
NOTE: Use the integrated strap to aid to secure the subframe and posts.

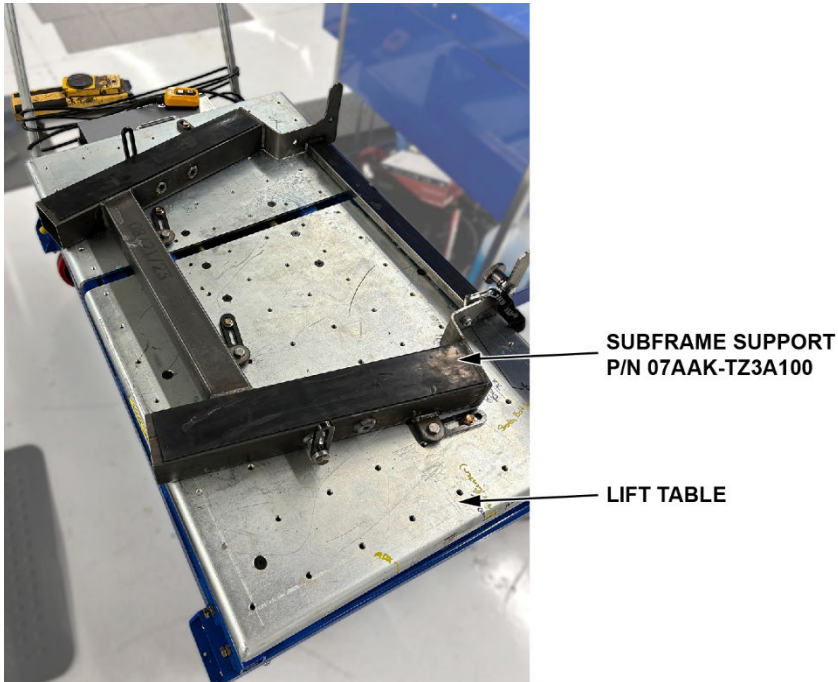

41. Raise the lift table until it contacts the subframe.
42. Unbolt the front subframe.
NOTE: Subframe Removal and Installation ([Click Here](#))
43. Lower the lift table with the subframe, engine, front knuckles, and transmission assemblies.
- Lower table and/or raise vehicle to clear the powertrain from the chassis.

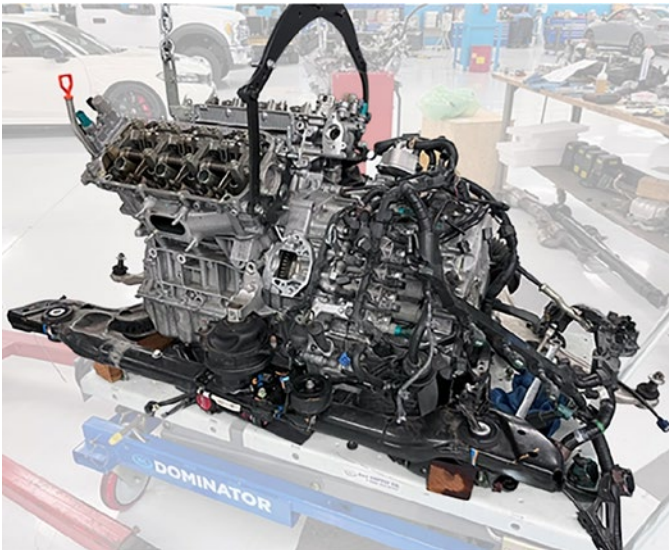

44. **If not removed during inspection B**, remove the passenger's side driveshaft spindle nut, then remove the driveshaft.
NOTE: *Front Driveshaft Removal and Installation* ([Click Here](#))
45. Remove the EPS heat shield.
46. Disconnect the bank 1 oxygen sensors, then remove the front and rear catalytic convertors.
NOTE: *Warm Up TWC Removal and Installation* ([Click Here](#))

47. Remove the intermediate shaft.
NOTE: Intermediate Shaft Removal and Installation ([Click Here](#))

48. Insert the transmission axle cap.



9AT TRANSMISSION CAP
(CAP, 9 AT PROTECTING)
P/N 07AAK-514A101

49. Remove the A/C compressor bracket.



BOLTS (4)
45 N·m
(33 lb-ft)

50. Remove the skid block, then disconnect the starter harness and remove the starter.
NOTE: *Starter Removal, Installation, and Performance Test* ([Click Here](#))

51. Install the engine support hanger attachment.
NOTE: Step 20.3, *Automatic Transmission Removal and Installation* ([Click Here](#))

52. Remove the rear engine mount upper bolt.
NOTE: *Engine Removal and Installation* ([Click Here](#))

53. Attach the engine hoist.
54. Lift engine to take the weight off of the mounts.
55. Remove the front engine mount stop and bracket.

NOTE: *Front Engine Mount Removal and Installation* ([Click Here](#))

56. Separate the engine from the transmission.

NOTE:

- Use a support, as needed, to hold the transmission.
- Pivot the engine away from the EPS rack counterclockwise to separate the AT.
- **Do not** lift the engine after the front mount has been removed.

57. Mount the engine to the engine stand.

58. Remove the drive plate.

NOTE: *Drive Plate Removal and Installation* ([Click Here](#))

59. Set **cylinder 1** to TDC.

NOTE: *Camshaft Timing Inspection* ([Click Here](#))

60. Reinstall the piston stoppers to **cylinders 2,3,4, and 6**.

61. Remove the timing belt covers on cylinder head and block, then remove the timing belt.

NOTE: *Timing Belt Removal and Installation* ([Click Here](#))

62. Rotate the engine **upside down** on the engine stand.

NOTE: Make sure appropriate engine fluid spill protection measures are taken.

63. Remove the oil pan.

NOTE: *Engine Oil Pan Removal and Installation* ([Click Here](#))

64. Remove the oil filter base, oil pump, and rear main seal cover.

NOTE: Steps 4-7, Crankshaft and CKP Pulse Plate Removal, Installation, and Inspection ([Click Here](#))

65. Install the crankshaft holder tool onto the crankshaft with the keyway at 6 o'clock position.

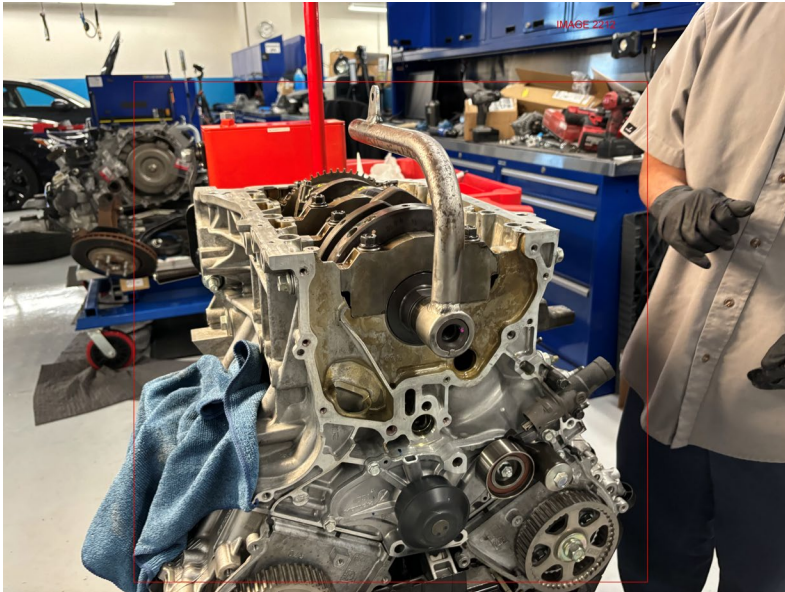

66. Use the crankshaft holder tool to rotate the crankshaft counterclockwise 45° from TDC.

NOTE: Rest the handle on the block.



HANDLE
Push the handle
this direction.

67. Remove the connecting rod caps for **cylinders 1, 3, and 4**.
68. Use the crankshaft holder tool to rotate the crankshaft clockwise 45° from TDC.

NOTE: Rest the handle on the block.

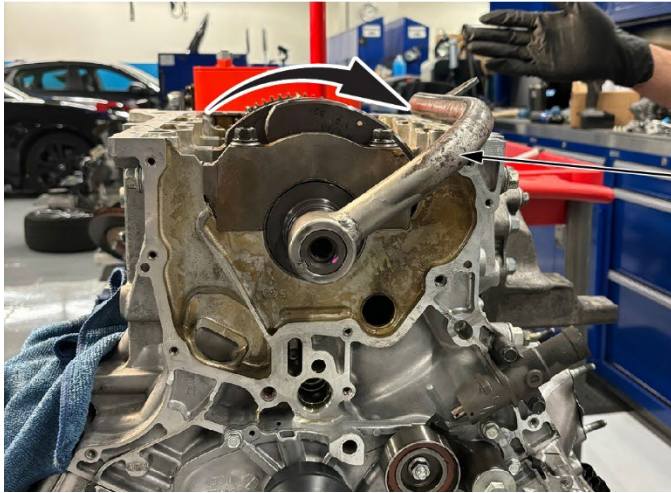

HANDLE
Push the handle
this direction.

69. Remove the connecting rod caps for **cylinders 2, 5, and 6**.
70. Use the crankshaft holder tool to rotate the crankshaft back to TDC.
71. Remove the crankshaft main bearing caps.
72. Lift the crankshaft out of the engine block.
73. Remove the thrust washers.
74. Swap the CKP pulse plate from the original crankshaft to the new crankshaft.

NOTE: Step 9, *Crankshaft and CKP Pulse Plate Removal, Installation, and Inspection* ([Click Here](#))

NOTE:

- Make sure there are no bent or damaged teeth.
- *Crankshaft and CKP Pulse Plate Removal, Installation, and Inspection* ([Click Here](#))

75. Make sure all piston and rod assemblies are pushed down into the cylinder.

NOTE: Make sure the connecting rods are properly aligned with the journals.

76. Install the new upper crankshaft main bearings into the engine block.
77. Install the new upper connecting rod bearings into the connecting rods.
78. Install the crankshaft install guide (07AAG-5J6A100) to the oil pan mating surface.



CRANK INSTALL GUIDE
P/N 07AAG-5J6A100

79. Install the connecting rod tie down tools (07AAB-5G0A300) into the bolt holes on **connecting rods 1 and 5**. Using rubber bands, secure the cylinder 1 and 5 connecting rods to the outer edge of the block using rubber bands connected to the crankshaft alignment tool.



CON ROD TIE DOWN
P/N 07AAB-5G0A300

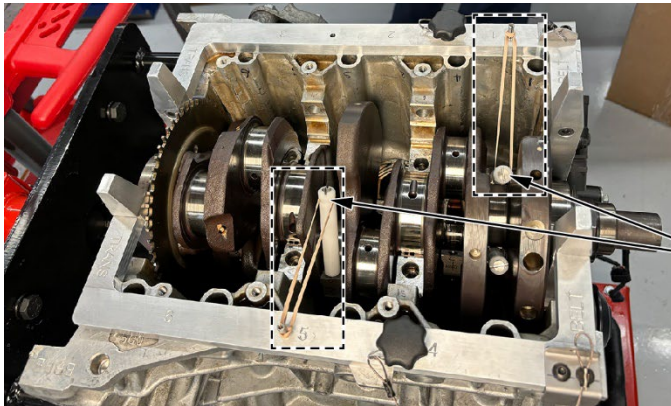

TIE DOWNS
Make sure the tie
downs are attached
to cylinders 1 and 5.

80. Install the crankshaft using the crank holder and crane. The crankshaft will drop in set to TDC.

NOTE:

- The connecting rod tie downs will guide the cylinder 1 and 5 connecting rods as the crankshaft is lowered.

Click here to view crankshaft installation video.

▶ PLAY VIDEO

Click here to view crank holder and M8 connecting rod tool.

▶ PLAY VIDEO

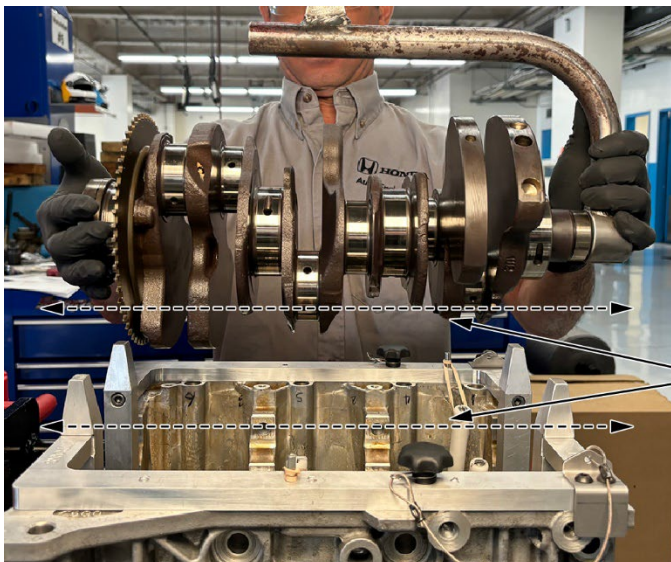

Keep the crank
parallel with the
block as it is
lowered down.

81. Remove the connecting rod tie downs from the cylinder 1 and 5 connecting rods.

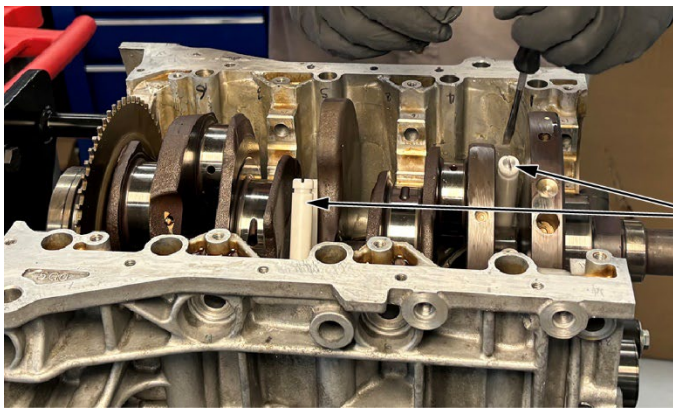

TIE DOWNS
Remove.

82. Insert new thrust washers.

83. Install the new main bearings onto the main bearing caps, then install and torque the main bearing caps.

NOTE: Crankshaft and CKP Pulse Plate Removal, Installation, and Inspection ([Click Here](#))



BEARING
Lubricate the bearing
prior to insertion.

84. Insert the crank holder tool back onto the crankshaft.

85. Use the crank holder tool to rotate the crankshaft counterclockwise **45 degrees** from TDC.

NOTE: Rest the handle on the block.



HANDLE
Push the handle
this direction.

86. Using the M8 rod holder tool, gently pull the connecting rods until the bearing contacts the crankshaft journal.

87. Install the lower connecting rod bearings into the connecting rod caps, then install and torque the connecting rod caps for **cylinders 1, 3, and 4**.

88. Use the crank holder tool to rotate the crankshaft clockwise **45 degrees** from TDC.

NOTE: Rest the handle on the block.



HANDLE
Push the handle
this direction.

89. Using the M8 rod holder tool, gently pull the connecting rods until the bearing contacts the crankshaft journal. Then install and torque the connecting rod bearing caps for **cylinders 2, 5, and 6**.

90. Install the oil pump and the oil filter base.

NOTE:

- New or original will depend on the Bearing Inspection Inquiry Team's judgement.
- Steps 9-13, *Crankshaft and CKP Pulse Plate Removal, Installation, and Inspection* ([Click Here](#))

91. Install the rear main seal cover.

92. Remove the piston stoppers.

93. Install the timing belt and all covers.

NOTE: *Timing Belt Removal and Installation* ([Click Here](#))

94. Install the baffle plate and oil strainer.

NOTE:

- New or original will depend on the Bearing Inspection Inquiry Team's judgement.
- Installation Step 7, *Piston, Ring, Pin, and Connecting Rod Removal and Installation* ([Click Here](#))

95. Clean and install the oil pan.

NOTE: *Engine Oil Pan Removal and Installation* ([Click Here](#))

96. Rotate the crankshaft 360° to ensure bearings allow free movement.

97. Install the drive plate.

NOTE: *Drive Plate Removal and Installation* ([Click Here](#))

98. Connect the engine to the transmission with alignment pins.

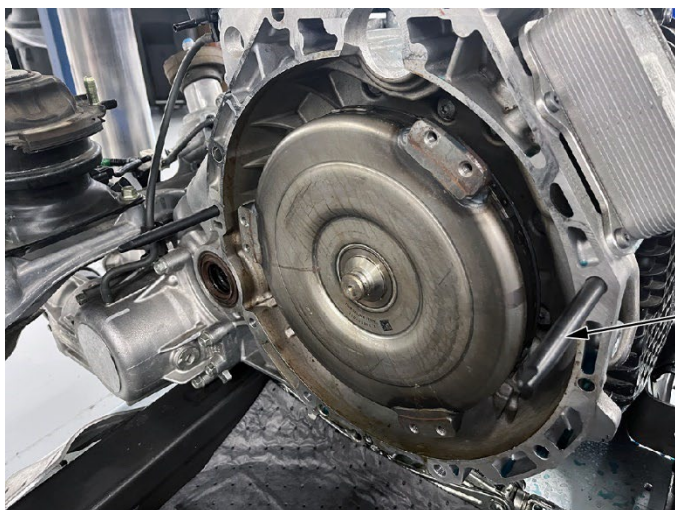

TRANSMISSION
ALIGN PIN
P/N 07AGG-5J4A100

99. Install the front engine mount bracket and rear engine mount bracket.

100. Install the starter, starter harness, and skid plate.

NOTE: Starter Removal, Installation, and Performance Test ([Click Here](#))

101. Install the following:

NOTE: See above for appropriate hyperlinks.

1. A/C Compressor Bracket
2. Front Catalyst with EGR pipe
3. Intermediate shaft (Remove the 9AT Protecting cap)
4. Drive shaft
5. Rear catalyst
6. Engine mount heat shield
7. Rear catalyst brace

102. Go to SUBFRAME INSTALLATION to continue with repair.

SUBFRAME INSTALLATION

1. Install the subframe alignment pins at opposite corners.

SUBFRAME GUIDE PIN
P/N 07AAG-TZ3A100



2. Raise the lift table to the chassis using the alignment pins to locate the subframe.

NOTE: Make sure the knuckles are aligned with the strut assemblies.



ALIGN

3. Install the subframe mounting bolts and torque to specification.

NOTE: *Subframe Removal and Installation* ([Click here](#))

4. Install the knuckle pinch bolts, wheel speed sensors, and calipers (both sides).

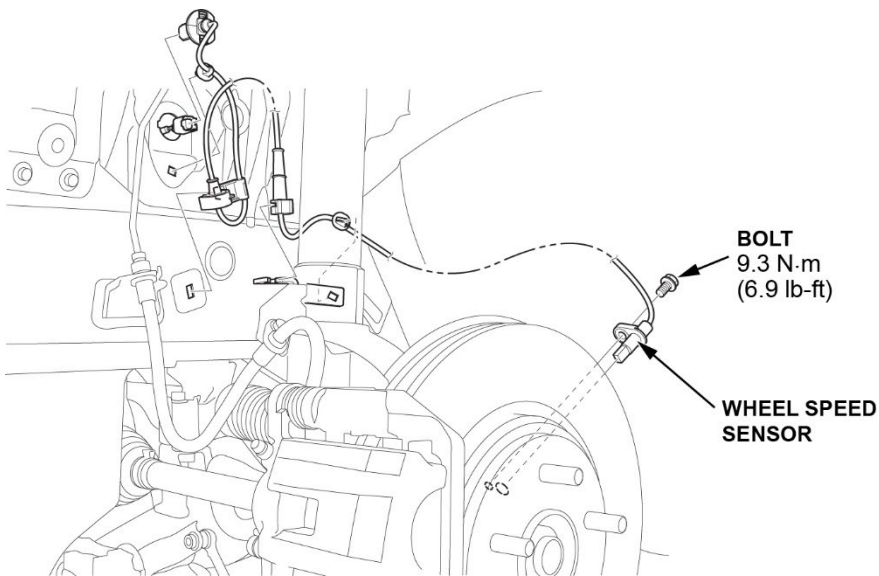
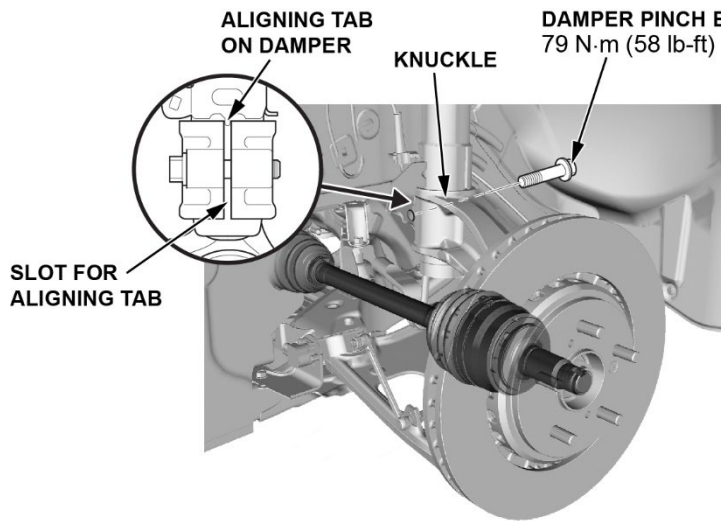

BOLTS
72 N·m (53 lb-ft)

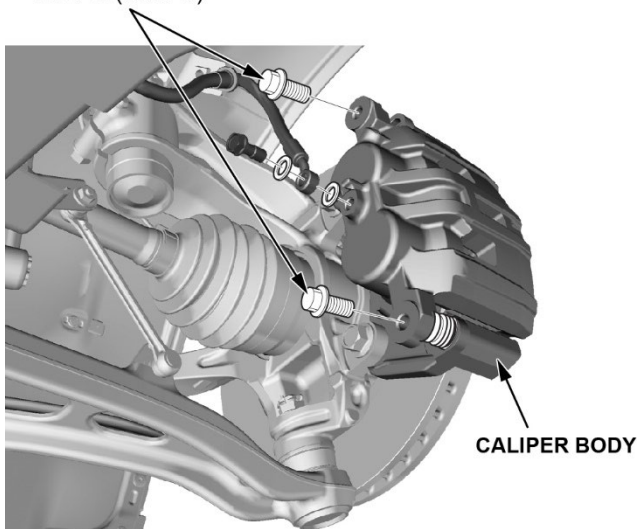

5. Install the stabilizer links (both sides).

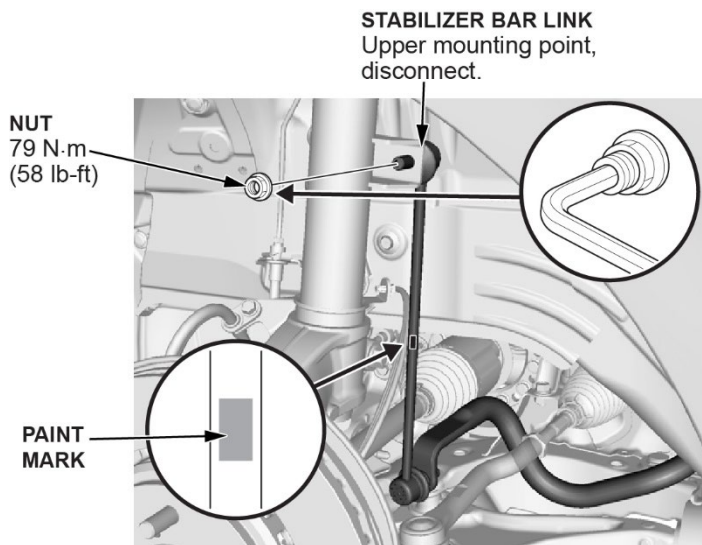

6. Install the 4 lower transmission bolts and torque to **75 N·m (55 lb-ft)**.
7. Install the torque converter bolts and torque to **27 N·m (20 lb-ft)**, then install the cover and torque to **12 N·m (9 lb-ft)**.
8. Connect the CKP Sensor and install the sensor cover and torque to **12 N·m (9 lb-ft)**.
9. Feed the 2 EPS connectors up through the floor and reconnect.
10. Install the passenger side console cover.
11. Connect the front active mount connector.
12. Install the underfloor TWC (A-pipe).
NOTE: Under-Floor TWC Removal and Installation [\(Click Here\)](#)
13. Reconnect the oxygen sensor.
14. **SH-AWD** – Connect the propeller shaft to the transfer case.

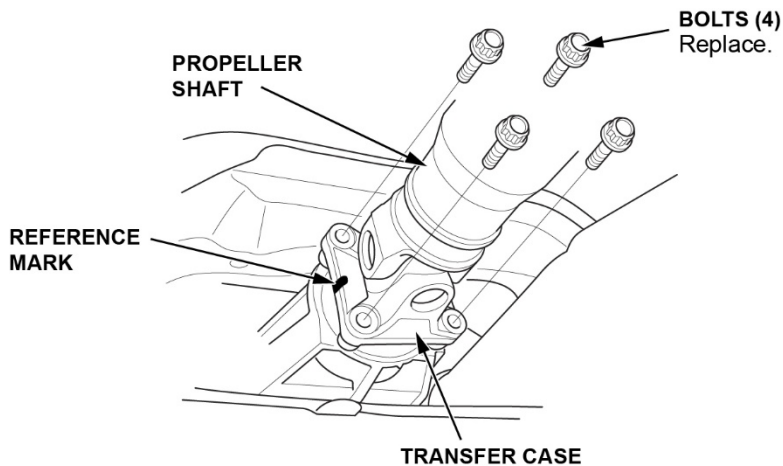

15. Install the subframe stiffener.

NOTE: Bolts are a must replace part.

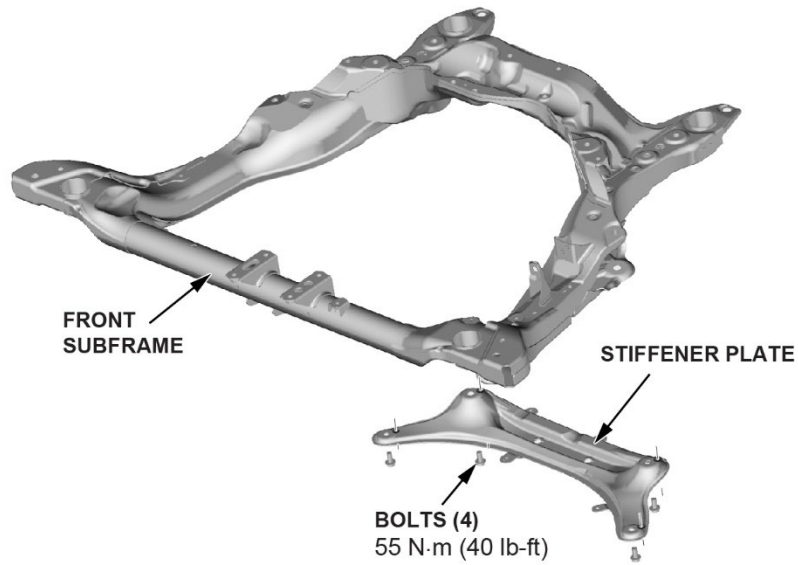

16. Install the transmission ground.

NOTE: *Engine Removal and Installation* [\(Click Here\)](#)

17. Secure the fender liners.

18. Lower the vehicle.

19. Connect the high-pressure fuel line.

20. Install the side engine mount bracket.

NOTE: *Side Engine Mount Removal and Installation* [\(Click Here\)](#)

21. Install the ATF cooler lines (if equipped).

- Push the cooler line onto fitting, then install the retaining clip.
- Attach the bracket and bolt.

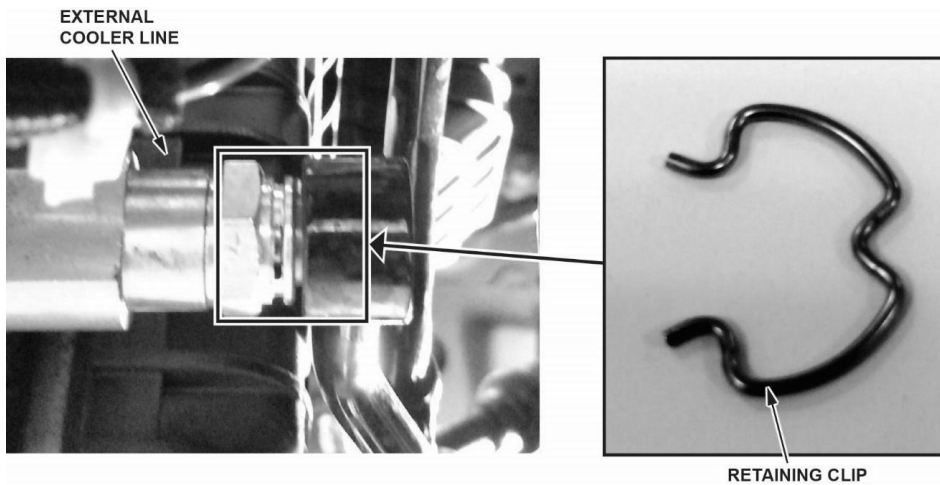
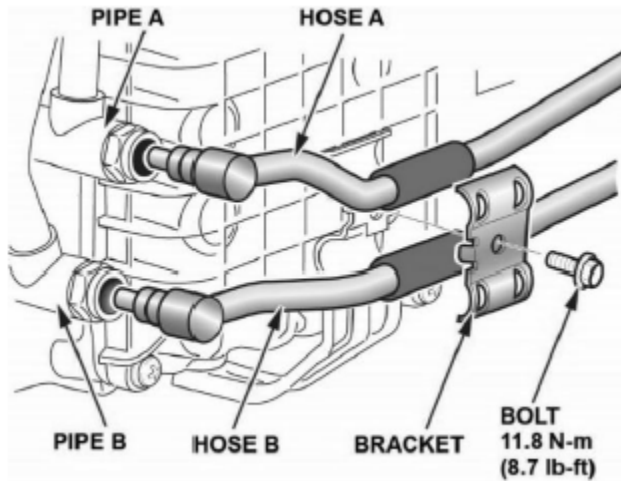

22. Reconnect the PCM and engine harness.

NOTE: *Engine Removal and Installation* ([Click Here](#))

23. Connect the brake booster and EVAP vacuum lines.

NOTE: *Engine Removal and Installation* ([Click Here](#))

24. Connect the radiator and heater hoses.

NOTE: Step 8, *Water Passage Removal and Installation* ([Click Here](#))

25. Install the A/C compressor.

NOTE: *A/C Compressor Removal and Installation* ([Click Here](#))

26. Install the alternator.

NOTE: Steps 5-6, *Alternator Removal and Installation* ([Click Here](#))

27. Install the accessory drive belt.

28. Install the condenser fan and reconnect the fan motor.

NOTE: *Radiator and A/C Condenser Fan, Motor, and Shroud Removal and Installation* ([Click Here](#))

29. Install the bulkhead braces.
NOTE: Step 5, *Radiator and A/C Condenser Fan, Motor, and Shroud Removal and Installation* ([Click Here](#))
30. Install the lower covers and splash shields.
NOTE: *Splash Shield Removal and Installation* ([Click Here](#))
31. Connect the transmission warmer hose.
NOTE: *ATF Warmer Removal and Installation* ([Click Here](#))
32. Install the bulkhead cover.
NOTE: *Front Bulkhead Cover Removal and Installation* ([Click Here](#))
33. Install the 12-volt battery.
NOTE: *Battery Removal and Installation* ([Click Here](#))
34. Install the air intake and filter box.
NOTE: *Air Cleaner Removal and Installation* ([Click Here](#))
35. Add engine oil.
NOTE: Engine Oil Replacement ([Click Here](#))
Capacity:
At Oil Change including Filter — 5.4L (5.7 US qt)
36. Add Coolant.
NOTE: *Coolant Replacement* ([Click Here](#))
Capacity:
At Coolant Change:
2016 — 8.7L (2.3 US gal)
2017–20 — 8.9L (2.35 US gal)
37. Install the steering joint and cover.
NOTE: *Steering Column Removal and Installation* ([Click Here](#))
38. Torque the spindle nut.
NOTE: *Front Driveshaft Removal and Installation* ([Click Here](#))
39. Install the passenger's side front wheel:
2016 — 108 N·m (80 lb-ft)
2017–20 — 127 N·m (94 lb-ft)
40. Purge the cooling system.
NOTE: *Coolant Replacement* ([Click Here](#))
41. Do the PCM reset. ([Click Here](#))
42. Do the CKP pattern learn. ([Click Here](#))
43. Do the Idle Speed Inspection ([Click Here](#))
44. Do the Ignition Timing Inspection ([Click Here](#))
45. Perform a wheel alignment.
NOTE: *Engine Removal and Installation* ([Click Here](#))
46. Do the Steering Angle Sensor Neutral Position Clear ([Click Here](#))

TIPS AND TRICKS

Here are a few tips and trick to help complete the inspection and repair.

Engine Serial Number is NOT legible.

The first step of every inspection is taking a photo of the Engine Serial Number. After capturing the photo, a thumbnail is displayed, and the application asks if you can read the Engine Number.



Before answering the question, confirm the image is in focus. Here are two methods:

- A. Use the **pinch-to-zoom** feature on the thumbnail image. Place two fingers on the image and slowly spread them apart to zoom in.

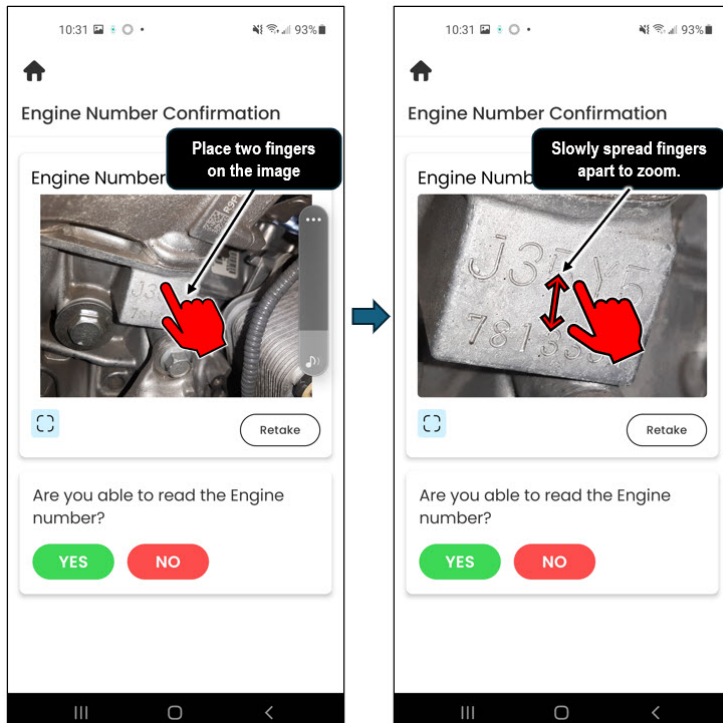

- B. Click on the **zoom** icon  to view the image full screen. The **pinch-to-zoom** feature can also be used on the full screen view.

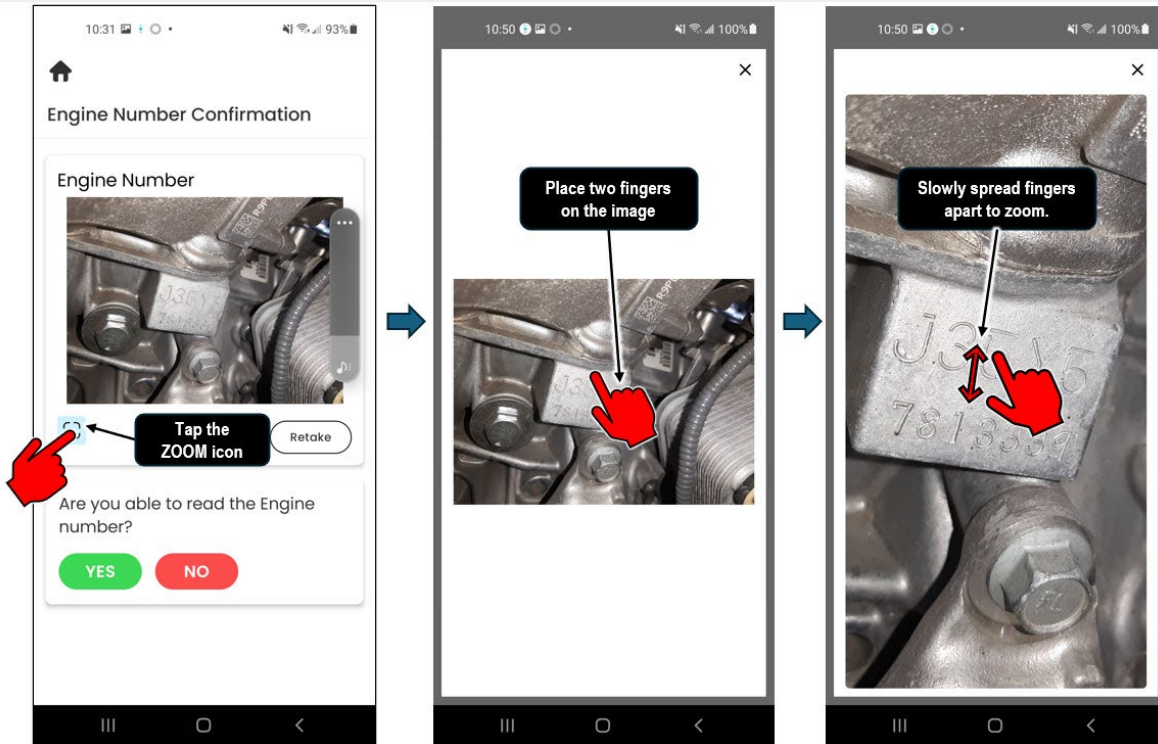

The Bearing Inspection Team Agents are required to confirm the engine serial number using the photo uploaded for review. If **NO** is selected in response to “Are you able to read the engine number?,” the application displays an example of an engine serial number before and after cleaning and refers you to *Tips and Tricks* for cleaning the Engine Number.



Cleaning techniques to make the engine serial number easy to read:

**Wire Brush and
Scotch Brite**



Sprayed with WD40



**Red Battery
Terminal Protector**



Used/Dirty Engine Oil



Submitting a Warranty Claim

Warranty Codes (Inspection and Repair) are issued as soon as the repair direction for **Bearings Only** is approved.

Select **Warranty Codes**, use the Inspection Code and Repair Code to file a warranty claim.

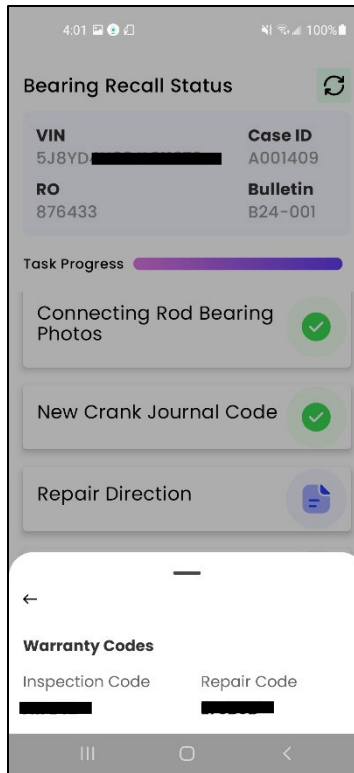
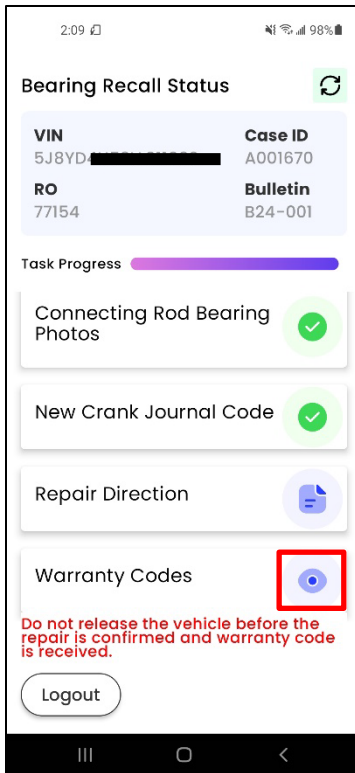

For Crankshaft and Engine Block replacements, the Warranty Repair Code is **not** issued until the Technician uploads the New Crankshaft Journal Codes (Crankshaft Repairs) or New Engine Block Serial Number (Engine Block Repairs).

Select **Warranty Codes**, use the Inspection Code and Repair Code to file a warranty claim.

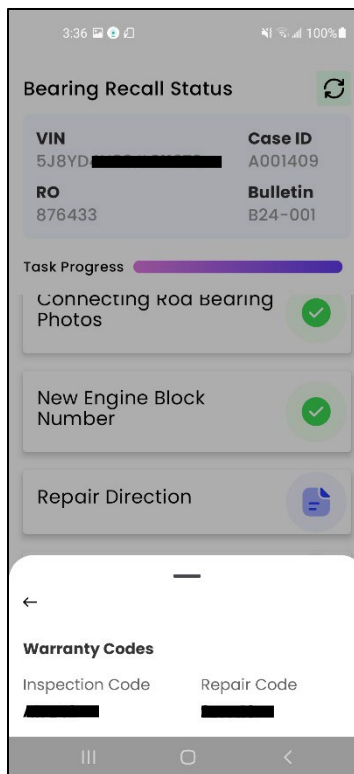
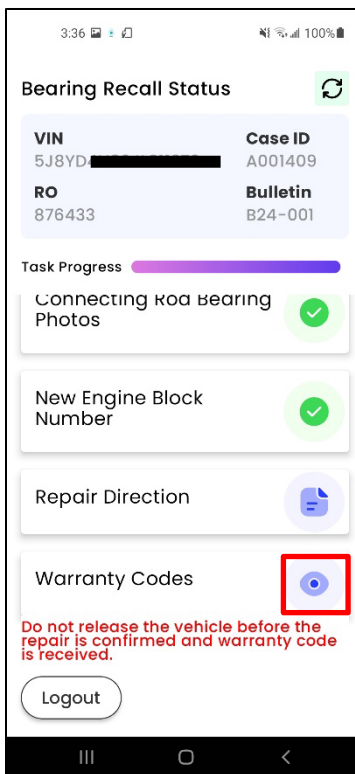

Creating a Bearing Inspection Inquiry.

If instructed by the application tool, create a Bearing Inspection Inquiry.

1. Log into iN.
2. Select SERVICE > REMAN PARTS / SPECIAL ORDERS > BEARING INSPECTION INQUIRY.
3. Select the BEARING INSPECTION INQUIRY.
4. Input the correct VIN.

The screenshot shows the Honda iN portal interface. The top navigation bar includes 'MY IN FAVORITES', 'HOME', 'SITE MAP', 'IN SUPPORT', 'CONTACT US', and 'ALERTS'. Below this is a secondary navigation bar with tabs for 'SALES', 'CERTIFIED PRE-OWNED', 'SERVICE', 'PARTS', 'F&I / HFS', 'EXECUTIVE MANAGEMENT', 'BUSINESS OFFICE', and 'ONLINE UNIVERSITY'. The 'SERVICE' tab is highlighted with a red box, and a red arrow points from it to the 'Bearing Inspection Inquiry' option in the left-hand menu. The main content area displays the 'Bearing Inspection Inquiry' form, which includes a 'Vehicle Information' section with a 'VIN' input field and a 'Submit' button. The footer contains the copyright notice: '© 2000 - 2024, American Honda Motor Co., Inc. All Rights Reserved.'

5. Input all vehicle information (including the correct VIN) to create a case.

The screenshot shows the 'Bearing Inspection Inquiry' form with all fields filled out. The form is divided into several sections: 'Dealer Information' (Dealer Number: 206501, Repair Order Number, DPTS ID/Name, SSN, Telephone No., Email, Email Confirm), 'Vehicle Information' (VIN: 5FNRL6H26KB023603, Mileage, Model: ODYSSEY, Model Year: 2019), and 'Problem Description' (Was the vehicle towed in?, If it was towed in, was it due to Engine failure?, Did you submit a clear photo of the Engine number?, Did you clean the bearings prior to submitting the photos?). The 'Submit', 'Save', and 'Cancel' buttons are visible at the bottom of the form. The footer contains the copyright notice: '© 2000 - 2024, American Honda Motor Co., Inc. All Rights Reserved.'

6. A 7-digit case reference number will be generated.
7. Call the Bearing Inspection Inquiry Team at (800) 824-6632. Press 9 to be routed to the correct department (do not contact TECH LINE for this). Give the answering agent the 7-digit reference number for repair direction.

NOTE:

- MAKING THE INCORRECT SELECTION WILL RESULT IN INCREASED WAIT TIMES.
 - **DO NOT** contact Tech Line for any inquiries about this safety recall. If instructed by the application tool, call the Bearing Inspection Inquiry Team at (800) 824-6632 (Select Option #9).
8. The BEARING INSPECTION application will give the **Repair Direction**. You will receive instructions via email on the repair method that includes the unique warranty code and the bearing sizes with their specific locations, if applicable. Parts will be AUTO shipped to your dealership. Make sure to advise the parts department with a copy of the RO.