



PREVOST

**SAFETY
RECALL**

SR23-19B

DATE :	August 2023	SECTION :	06 ELECTRICAL
SUBJECT:	FRONT RH TURN SIGNAL MALFUNCTION – ADDITION OF A RESISTOR HARNESS		

Revision: B

At module AE49, connector J2 pinout wrongly identified.
Was identified J2.10, corrected for J2.1

09-20-2023

APPLICATION

NOTICE TO SERVICE CENTERS	
<i>Verify vehicle eligibility by checking warranty bulletin status with SAP or via ONLINE WARRANTY SYSTEM available on Service / Warranty tab of PrevoSt website.</i>	
Model	VIN 
H3-45 coaches Model Year: 2023 - 2024	<p style="text-align: center;">The following vehicles</p> <p style="text-align: center;">2PCH33490<u>PC</u> [REDACTED] 2PCH33496<u>PC</u> [REDACTED] 2PCH33498<u>PC</u> [REDACTED] 2PCH33494<u>PC</u> [REDACTED]</p> <p style="text-align: center;">And from 2PCH3349X<u>RC</u> [REDACTED] up to 2PCH33495<u>RC</u> [REDACTED] incl.</p>
H3-45 VIP motorhomes Model Year: 2022 - 2024	<p style="text-align: center;">The following vehicles</p> <p style="text-align: center;">2PCVS3498<u>NC</u> [REDACTED] 2PCV33490<u>NC</u> [REDACTED] 2PCVS3491<u>NC</u> [REDACTED] 2PCVS349X<u>NC</u> [REDACTED] 2PCVS3491<u>NC</u> [REDACTED]</p> <p style="text-align: center;">And from 2PCVS3499<u>PC</u> [REDACTED] up to 2PCVS3492<u>RC</u> [REDACTED] incl.</p>
<p>This Safety Recall does not necessarily apply to all the above-mentioned vehicles. Some vehicles may also have been modified before delivery. The owners of the vehicles affected by this recall will be advised by a letter indicating the Vehicle Identification Number (VIN) of each vehicle concerned.</p>	

DESCRIPTION

On the vehicles affected by this recall, it is necessary to add a resistor on the RH + LH turn signals as well as RH + LH low beams electrical circuits to solve an issue affecting the front RH turn signal.

MATERIAL

Order kit **SR23-19** which includes the following parts:

Part No.	Description	Qty
0600179	RESISTOR, HARNESS (connector C60)	1
562286	TERMINAL, DEUTSCH TYPE 16 PIN 20-16AWG	2

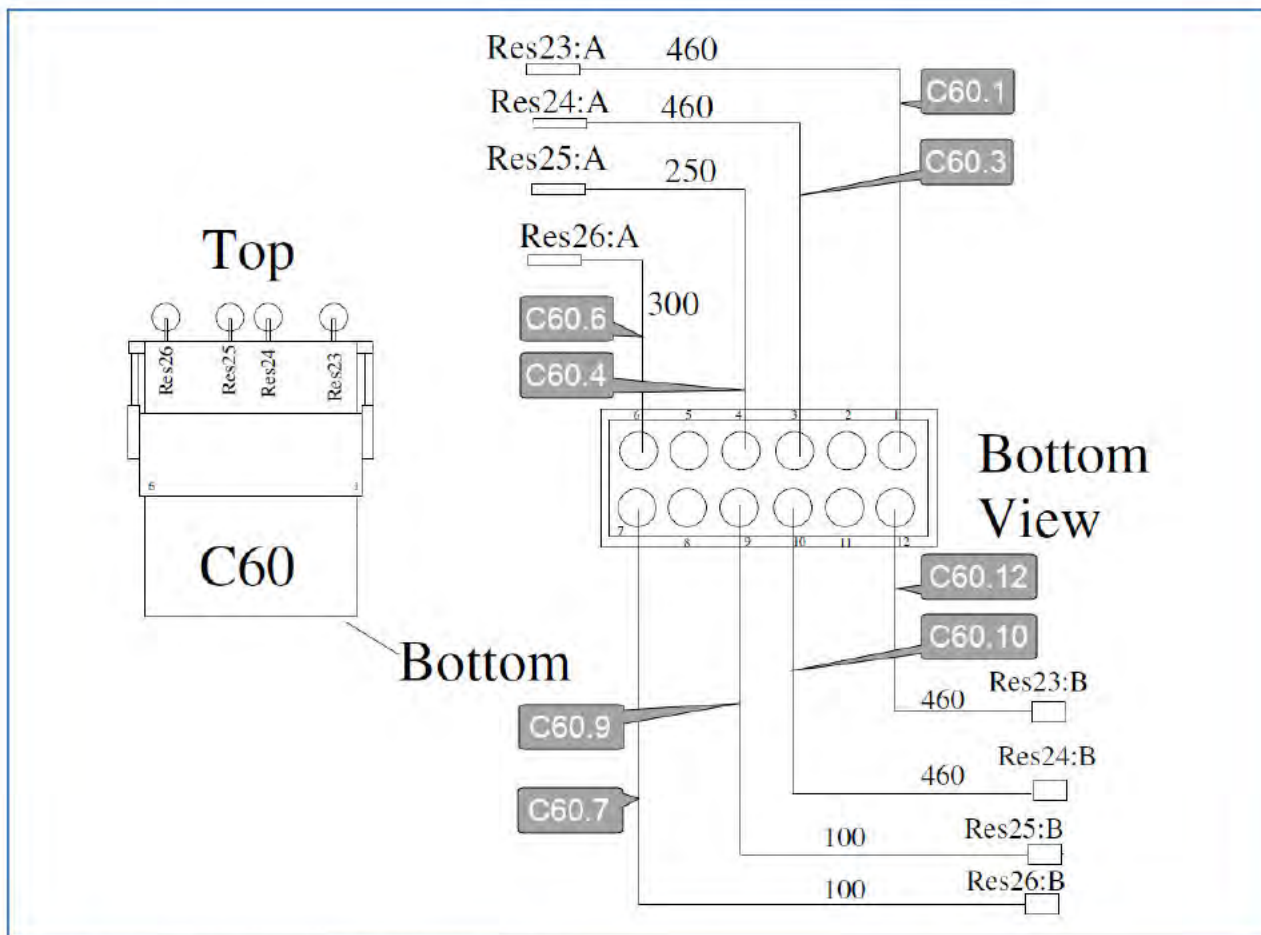

FIGURE 1: 0600179 RESISTOR HARNESS (CONNECTOR C60)

NOTE

Material can be obtained through regular channels.

SAFETY PRECAUTIONS

- Eye protection should always be worn when working in a shop.
- Rules for Personal Protection Equipment should always be respected. Wear your PPE including but not limited to the following:



**Safety
First!**



PROCEDURE



DANGER

Park vehicle safely, apply parking brake, stop the engine. Prior to working on the vehicle, set the ignition switch to the OFF position and trip the main circuit breakers equipped with a trip button. On Commuter type vehicles, set the battery master switch (master cut-out) to the OFF position.

Lockout & Tag out (LOTO) must be performed during set-up, maintenance or repair activities. Refer to your local procedure for detailed information regarding the control of hazardous energy.

1. Remove the panel on the right side of the dashboard. The panel is secured with fasteners as seen on the images below.

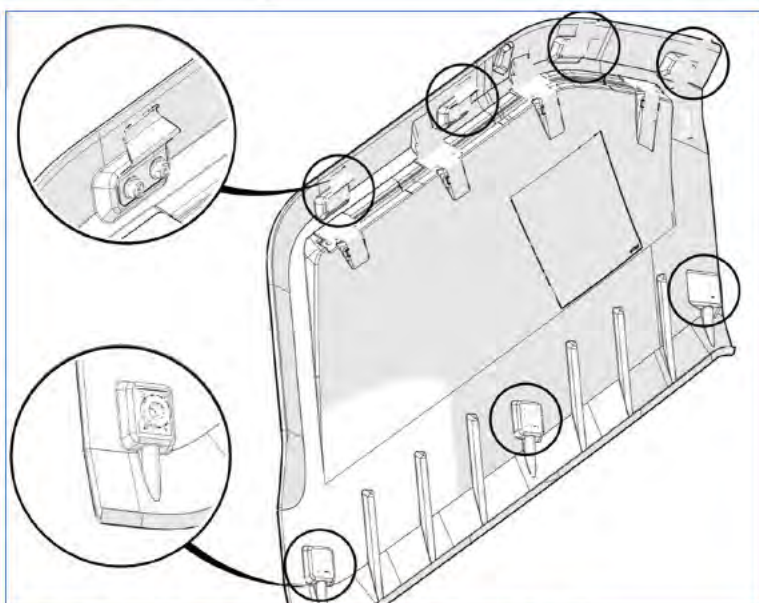

FIGURE 2: ATTACHMENT POINTS AT THE BACK OF THE PANEL

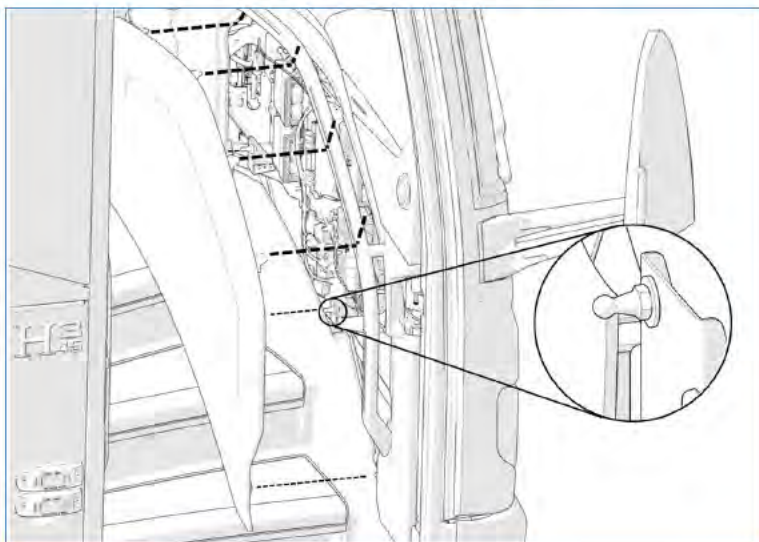

FIGURE 3

2. To remove the panel, pull (unsnap) the bottom of the panel in three (3) places by pulling toward you and then pull the panel down to disengage the top.

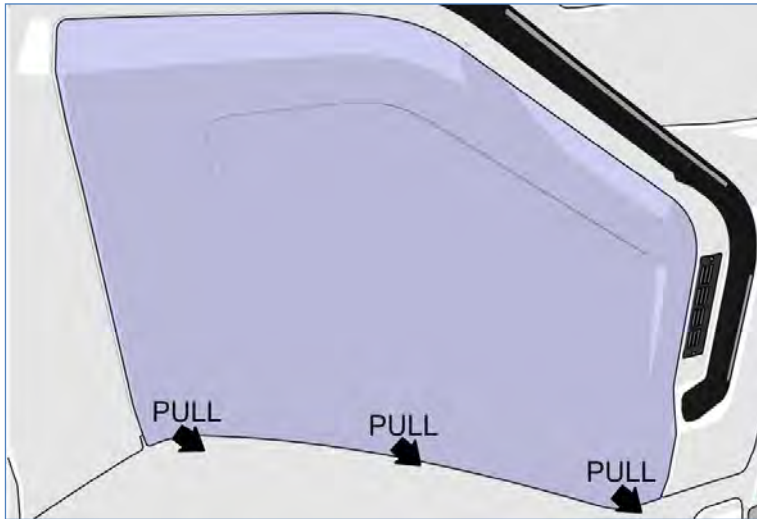

FIGURE 4

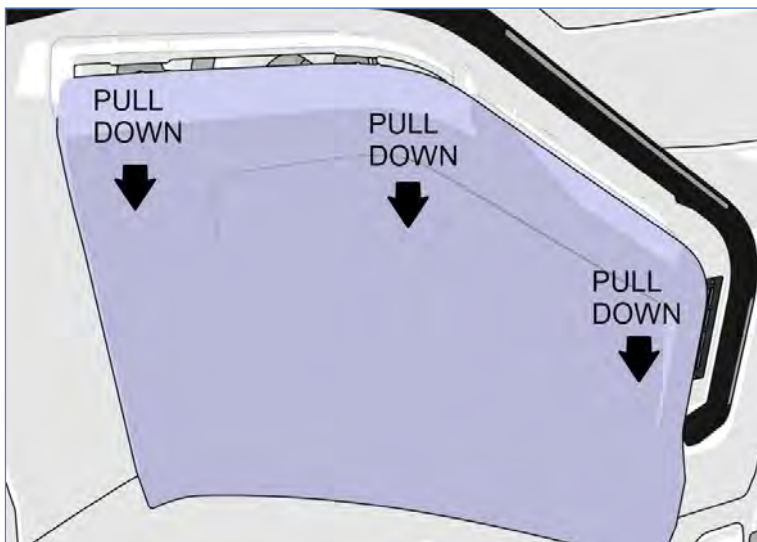

FIGURE 5

- On the dashboard electrical control panel, find connector RES4 located between MUX modules AE49 & AE47.

NOTE

AE47 (item 12 Figure 6) is located behind AE48 (item 8 Figure 6)

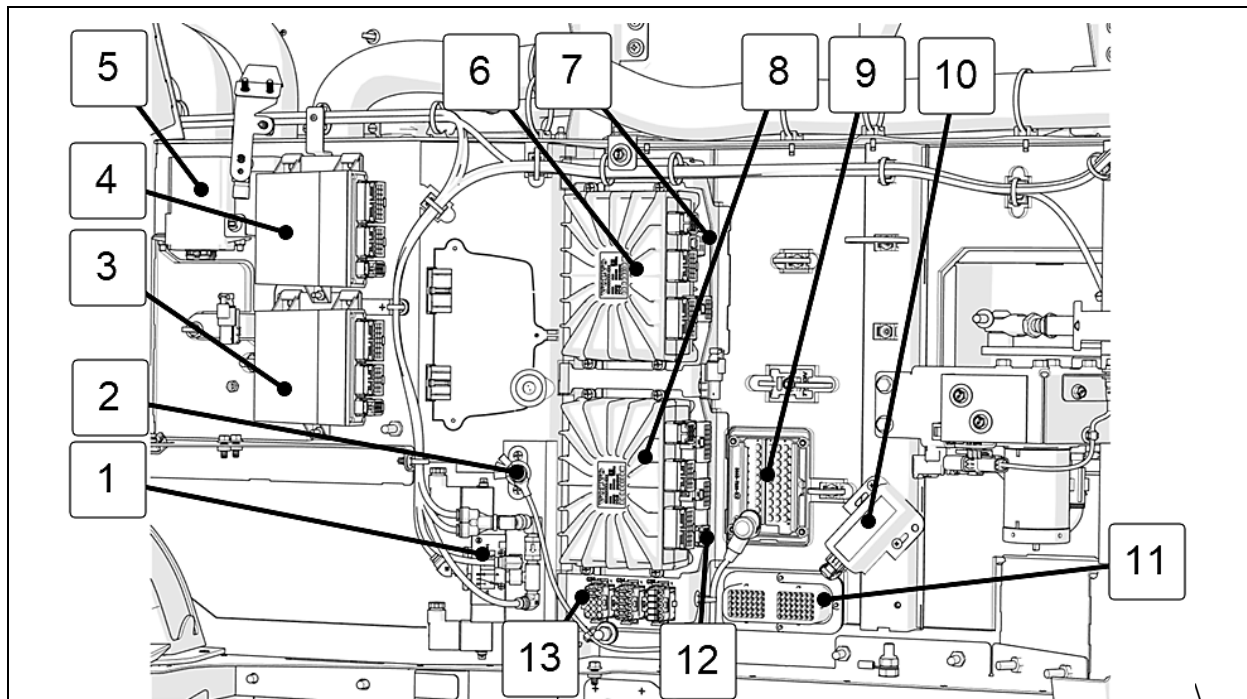

FIGURE 6: DASHBOARD CONTROL PANEL - H3 SERIES SHOWN

<ol style="list-style-type: none"> Entrance door solenoid valve Electronic ground stud AE56 multiplex module AE55 multiplex module A99 ELD gateway AE49 multiplex module A21 wiper control AE48 multiplex module VEC RHC Light pipe module (headlights) C42 AE47 multiplex module 	<ol style="list-style-type: none"> <ul style="list-style-type: none"> C28 diode block <ul style="list-style-type: none"> Res12 (Res18 VIP) LH mirror Res13 RH mirror Spare Spare Spare C34 diode block <ul style="list-style-type: none"> Res2 air recirc damper (spare VIP) Res9 defroster Res10 dashbd damper (Res2 air recirc damper VIP) Res11 pwm switch (Res10 dashboard damper VIP) Spare (Res12 pwm switch VIP) C35 diode block <ul style="list-style-type: none"> Spare (D66 water pump VIP) Spare (D4 front door) D7 open door sw (Spare VIP) D2 refrigerant solenoid So7 Spare
-------------------------------------------------------------------------------------------------------------------------------------------------------------------------------------------------------------------------------------------------------------------------------------------------------------------------------------------------------------------------------------------------------------------	---------------------------------------------------------------------------------------------------------------------------------------------------------------------------------------------------------------------------------------------------------------------------------------------------------------------------------------------------------------------------------------------------------------------------------------------------------------------------------------------------------------------------------------------------------------------------------------------------------------------------------------------------------------------------------------------------------------------------------------------------------------------------------------------------------------------------------------------------------------------------------------------

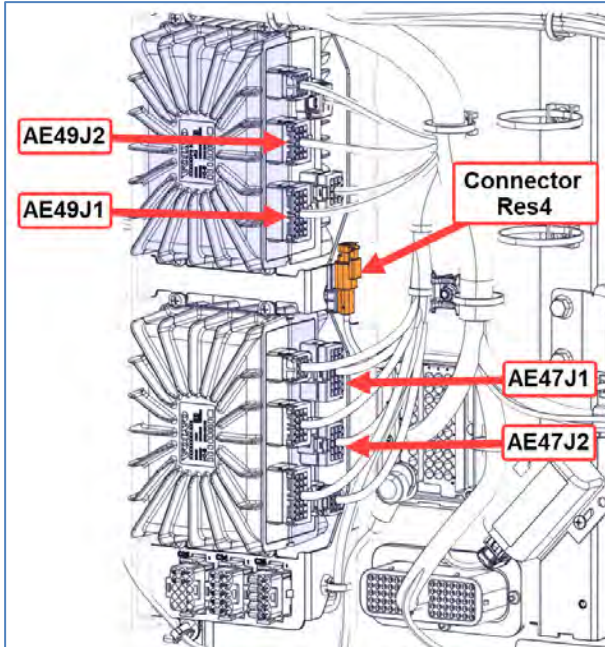

FIGURE 7: CONNECTOR RES4 LOCATION

4. Detach connector RES4 from its support and secure on nearby harness using a nylon tie.
5. Secure connector C60 of *resistor harness 0600179* on the support in place of connector RES4.

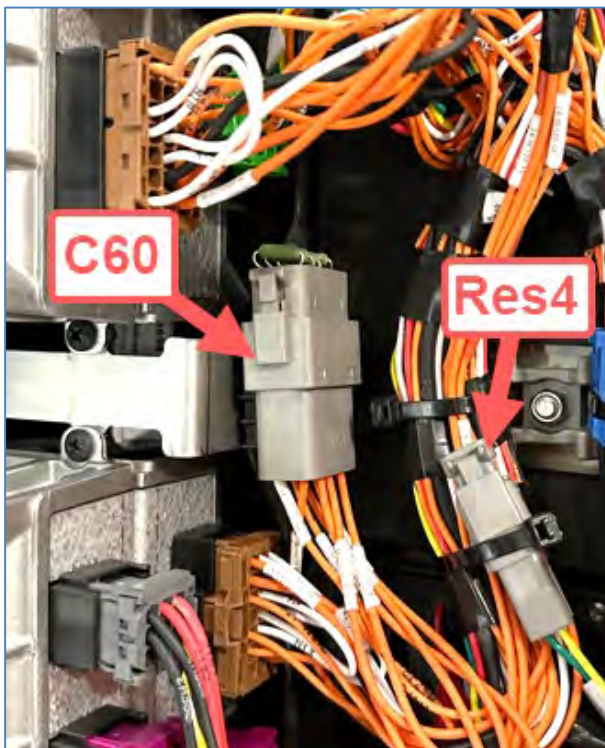

FIGURE 8

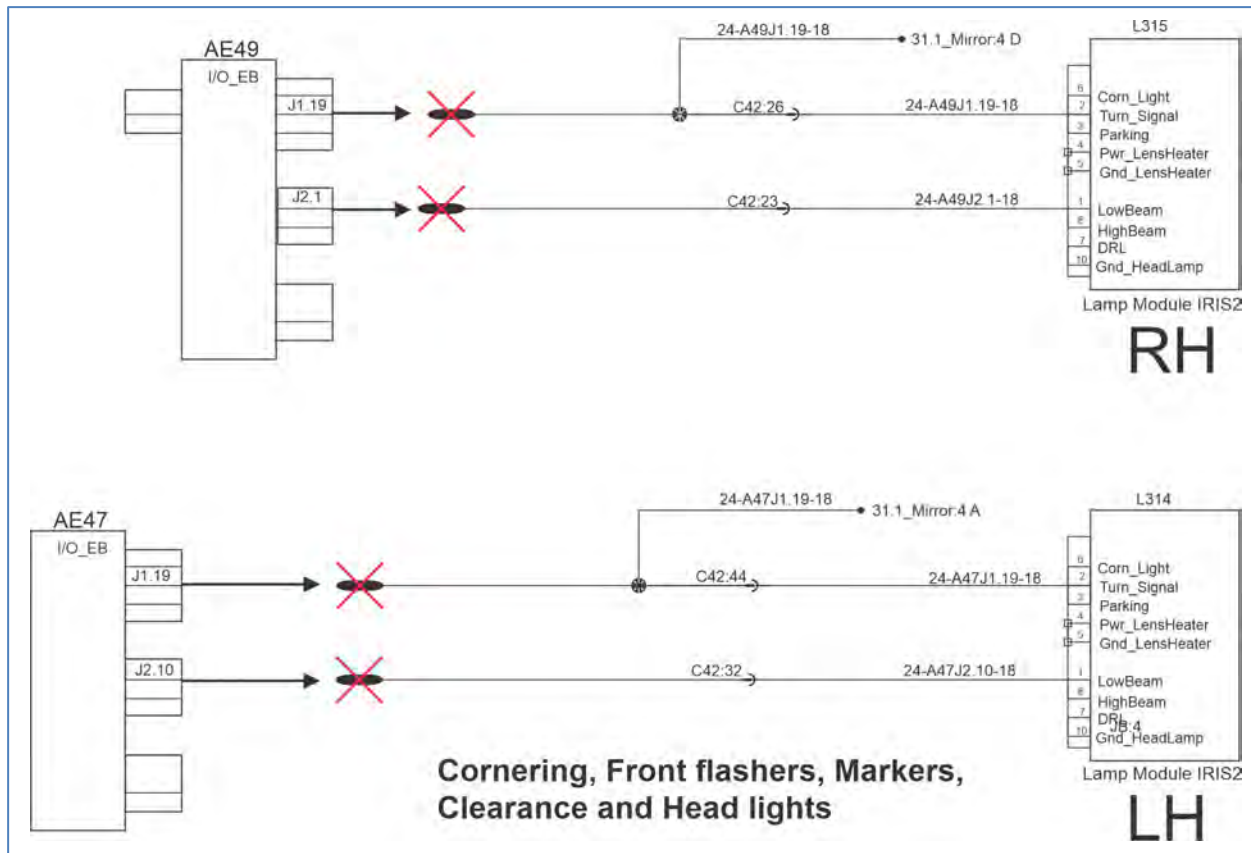

FIGURE 9

6. Disconnect the RH turn signal circuit (A49J1.19) from MUX module AE49 at J1.19. Cut and discard the terminal (Figure 9).

Refer to Appendix at the end of this document

7. Disconnect the RH low beam circuit (A49J2.1) from MUX module AE49 at J2.1. Cut and discard the terminal (Figure 9).
8. Disconnect the LH turn signal circuit (A47J1.19) from MUX module AE47 at J1.19. Cut terminal and discard (Figure 9).
9. Disconnect the LH low beam circuit (A47J2.10) from MUX module AE47 at J2.10. Cut terminal and discard (Figure 9).

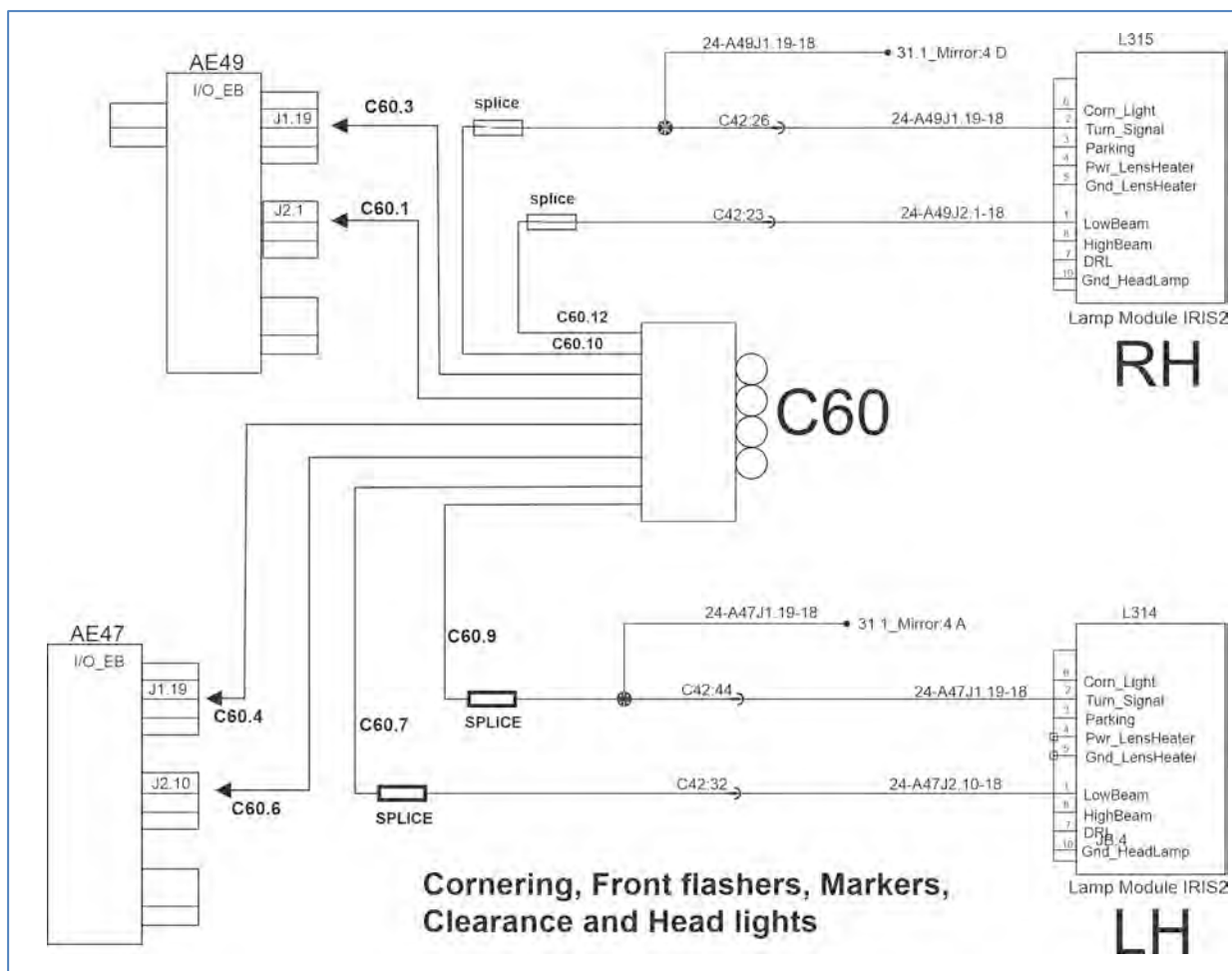
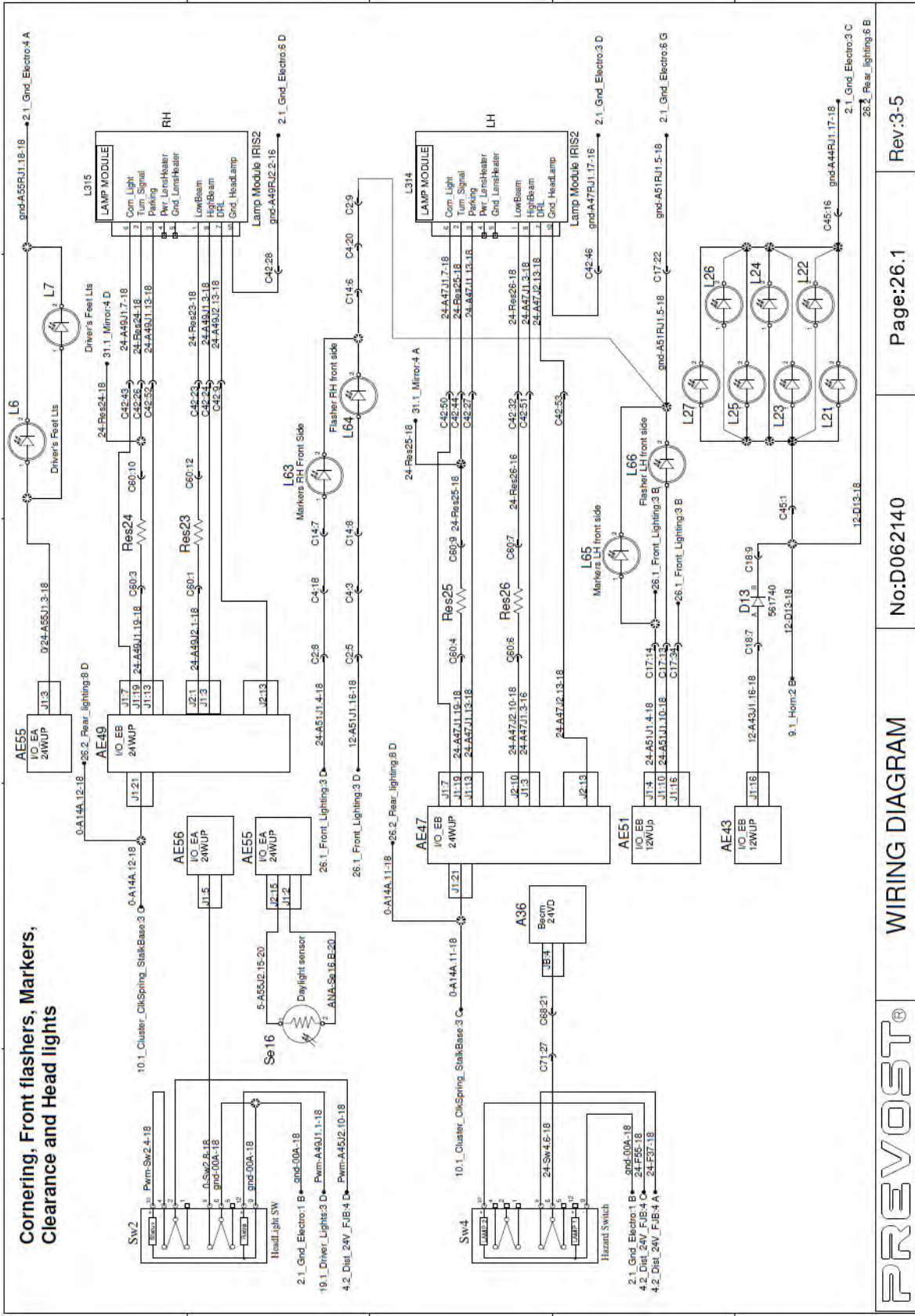

FIGURE 10

10. Insert wire C60.3 from C60 into AE49J1.19.
11. Insert wire C60.1 from C60 into AE49J2.1.
12. Insert wire C60.4 from C60 into AE47J1.19.
13. Insert wire C60.6 from C60 into AE47J2.10
14. Splice RH turn signal circuit A49J1.19 from RH lamp module to C60.10 wire from C60.
15. Splice RH low beam circuit A49J2.1 from RH lamp module to C60.12 wire from C60.
16. Splice LH turn signal circuit A47J1.19 from LH lamp module to C60.9 wire from C60.
17. Splice LH low beam circuit A47J2.10 from LH lamp module to C60.7 wire from C60.



Cornering, Front flashers, Markers, Clearance and Head lights

FIGURE 11

18. Take note that the DEUTSCH TYPE 16 PIN 20-16AWG terminals (2x) p/n 562286 included in the kit are not required for this installation.

19. Secure all the wires to nearby harness using nylon ties.

20. Confirm the proper functioning of the new installation. Test the following items:

- Right turn signal (headlight module and mirror if applicable)
- Left turn signal (headlight module and mirror if applicable)
- RH & LH low beam

21. Cut the following image. Using transparent tape, affix on the *compartment decal 0610626* to identify the new resistor block for future troubleshooting.

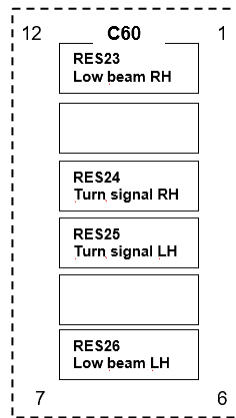

PARTS DISPOSITION

Discard waste according to applicable environmental regulations (Municipal/State[Prov.]/ Federal)

WARRANTY

This modification is covered by Prevost's normal warranty. We will reimburse you the parts and 1 hour(s) (1.0) of labor upon receipt of a completed A.F.A. Please submit claim via our Online Warranty System, available at www.prevostcar.com (under service \ warranty section). Use Claim Type: "Bulletin/Recall" and select "Safety Recall SR23-19".

OTHER

VBC Bulletin	N/A
Fail Code	06.05
Defect Code	09
Syst.Cond	R
Causal Part	930028

Access all our Service Bulletins on
<http://techpub.prevostcar.com/en/>
or scan the QR-Code with your smart phone.
E-mail us at **technicalpublications_prev@volvo.com** and
type "ADD" in the subject to receive our warranty bulletins by e-mail.



APPENDIX

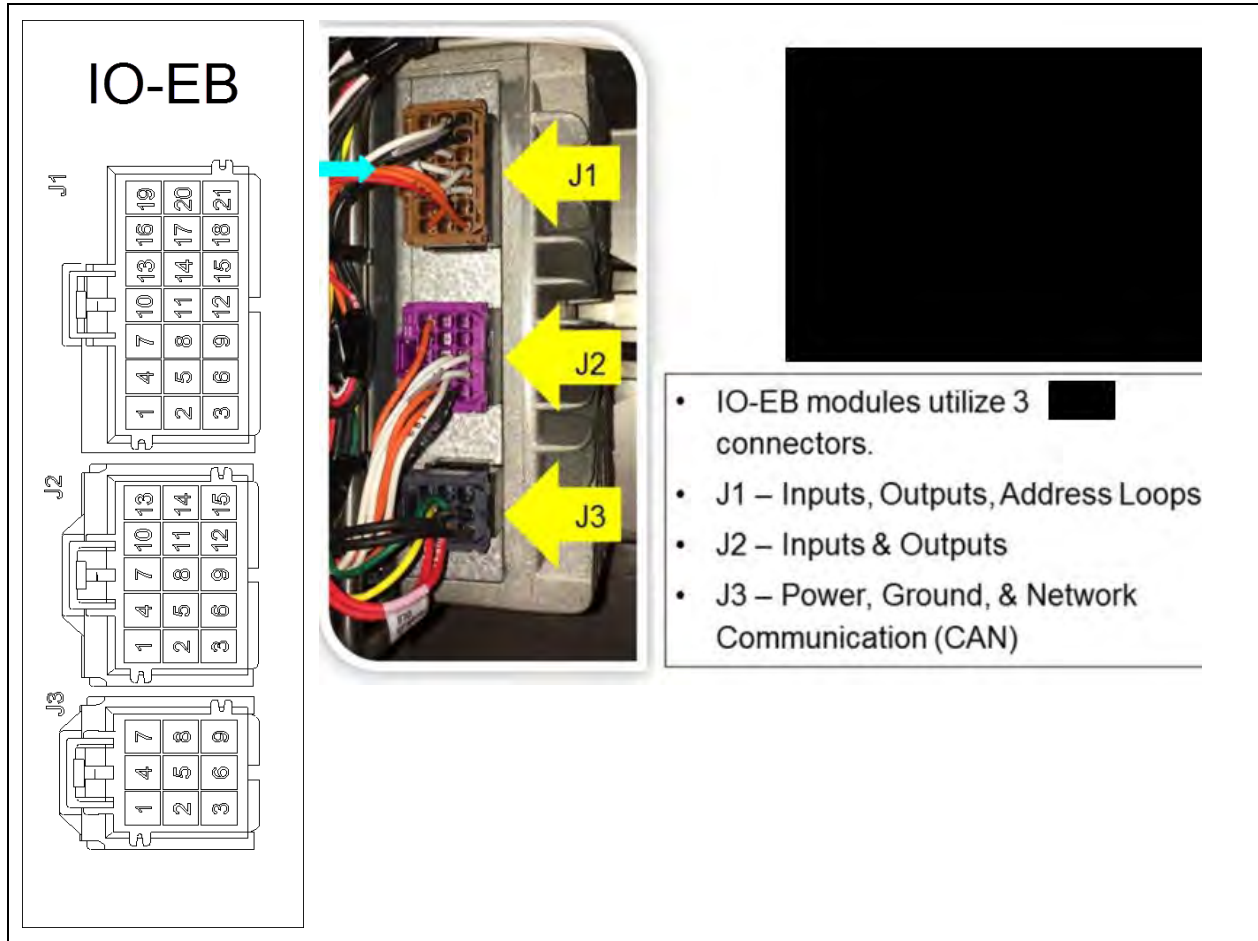

FIGURE 12: I/O-EB MODULES CONNECTOR PIN-OUT - BACK PROBING VIEW

I/O-EA & I/O-EB MUX modules Connector: AMP MCP 2.8

Contact loading of housings

Loading the contacts is only possible if the secondary lock is in the unlock position.

Proper orientation of the contact is important. If the orientation is incorrect, the contact stops too early in the region of the secondary lock and the whole crimp stands out from the housing. With correct orientation the secondary lock stops with a metallic "click" sound.

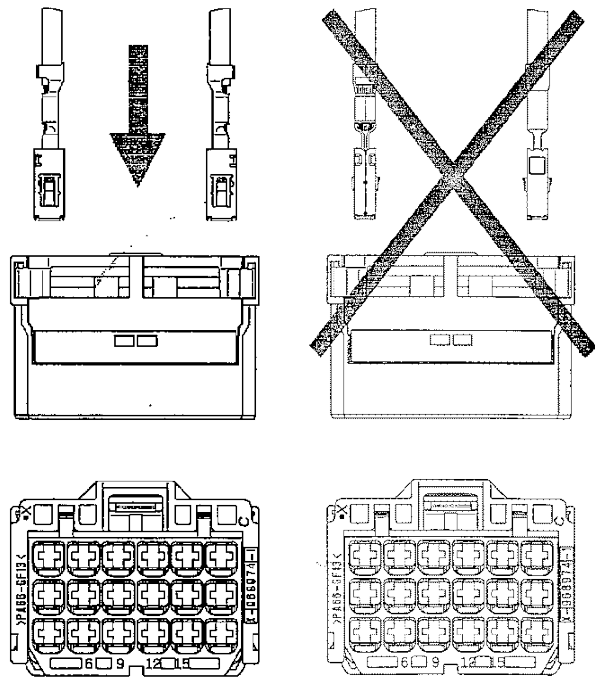

Locking the secondary lock

Delivery state of the secondary lock is the open position. In this position the AMP MCP2.8 contacts can be loaded. After that the secondary lock is moved into the final locking position by hand.

At a sufficient large surface a perpendicular force is initiated by (preferably) the thumb of one hand. Proper final position is reached a click noise can be heard. Make sure that both sides are locked.

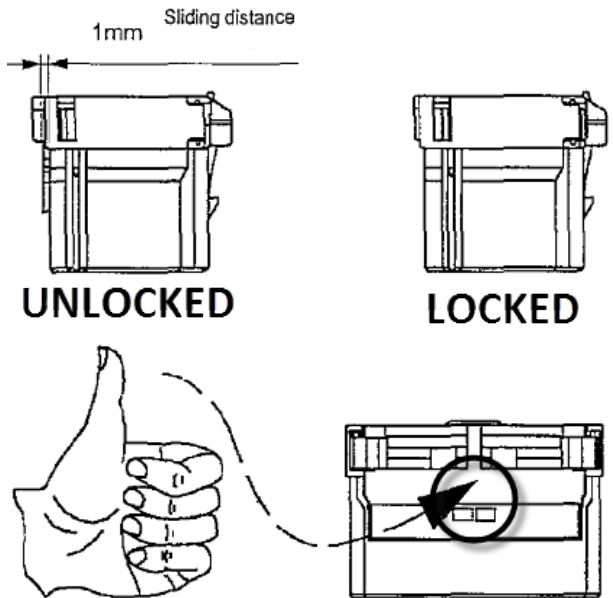

Unlocking the secondary lock

To unlock the secondary lock on these housings, a simple solid commercial ball pen is sufficient. The ball pen has to be inserted perpendicularly according to the image, between the locking latch of the housing and the secondary lock block. Then it will be pushed with care until the opening is felt (a "click" sound can be heard).

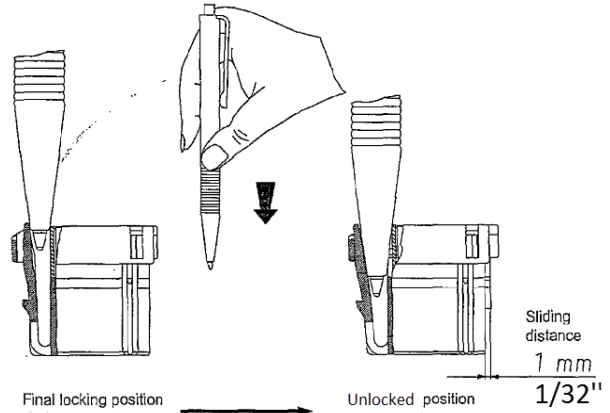
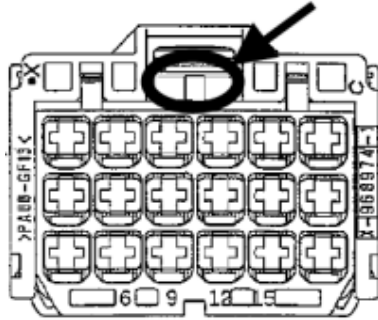

Extracting the contacts from housings

To extract contacts, the secondary lock has to be in the unlock position. The tool has to be inserted from connection side into the cavity of housing up to the stop; the contact will be unlocked thereby. Keep the tool in that position and then take the contact out by pulling on the cable. Note: Do not pull the cable before unlocking the contact; on the other hand by pressing the cable gently against the cable outlet direction the unlocking procedure will be facilitated.



EXTRACTOR/TOOL: Prevost 568103