



Technical Service Bulletin

TSB 120823
Revision 5
January 19th, 2024

Your truck/trailer may be equipped with a hoist that requires prompt servicing, in accordance with this TSB, to prevent premature hoist failure. This TSB will help you identify whether your truck/trailer must have this remedy performed. If your truck/trailer is within the affected population, please promptly perform the remedy described in this TSB.

REMOVE UNITS FROM SERVICE IMMEDIATELY

Do not operate any dump functions until this TSB has been completed.

Subject: Champion Hoist Relief Valve Installation
Affected Products: DCL1000SE25, DCL800SM20, DCL800M25, DCL800SM30, DCL800TM25, DCL800TM30, DCL800TM20, DCL800TM25, DCL800TM30, DCL750TM25
Affected Product Range: All units with the Champion hoist installed
Remedy Required: A relief valve is required on the retract side of the hoist to prevent premature hoist failure.

Affected Unit Identification

How to identify if your unit is affected:

Use the flowchart and tables below to determine whether your unit is affected. Fill in the information below for each unit and return a copy of this sheet to ODB.

Serial Number	Model	Hoist Type	Valve Type

Signed: _____

Date: _____

Printed Name: _____

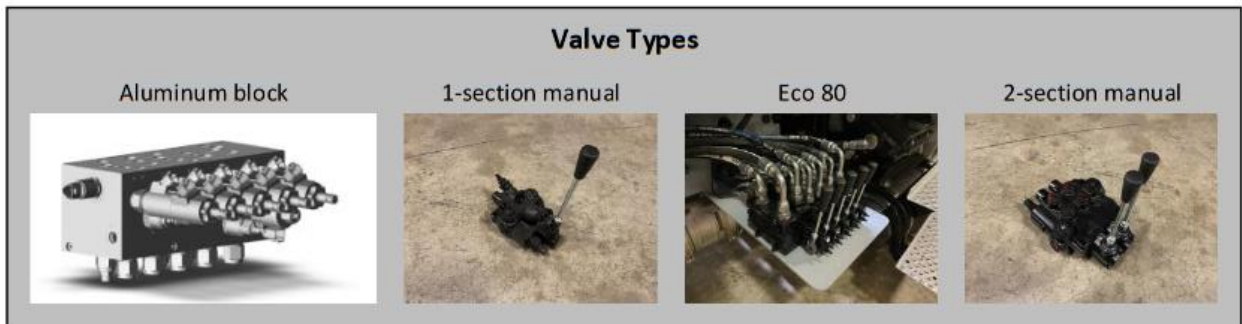
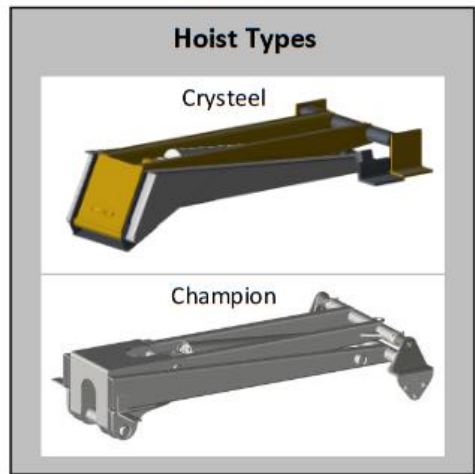
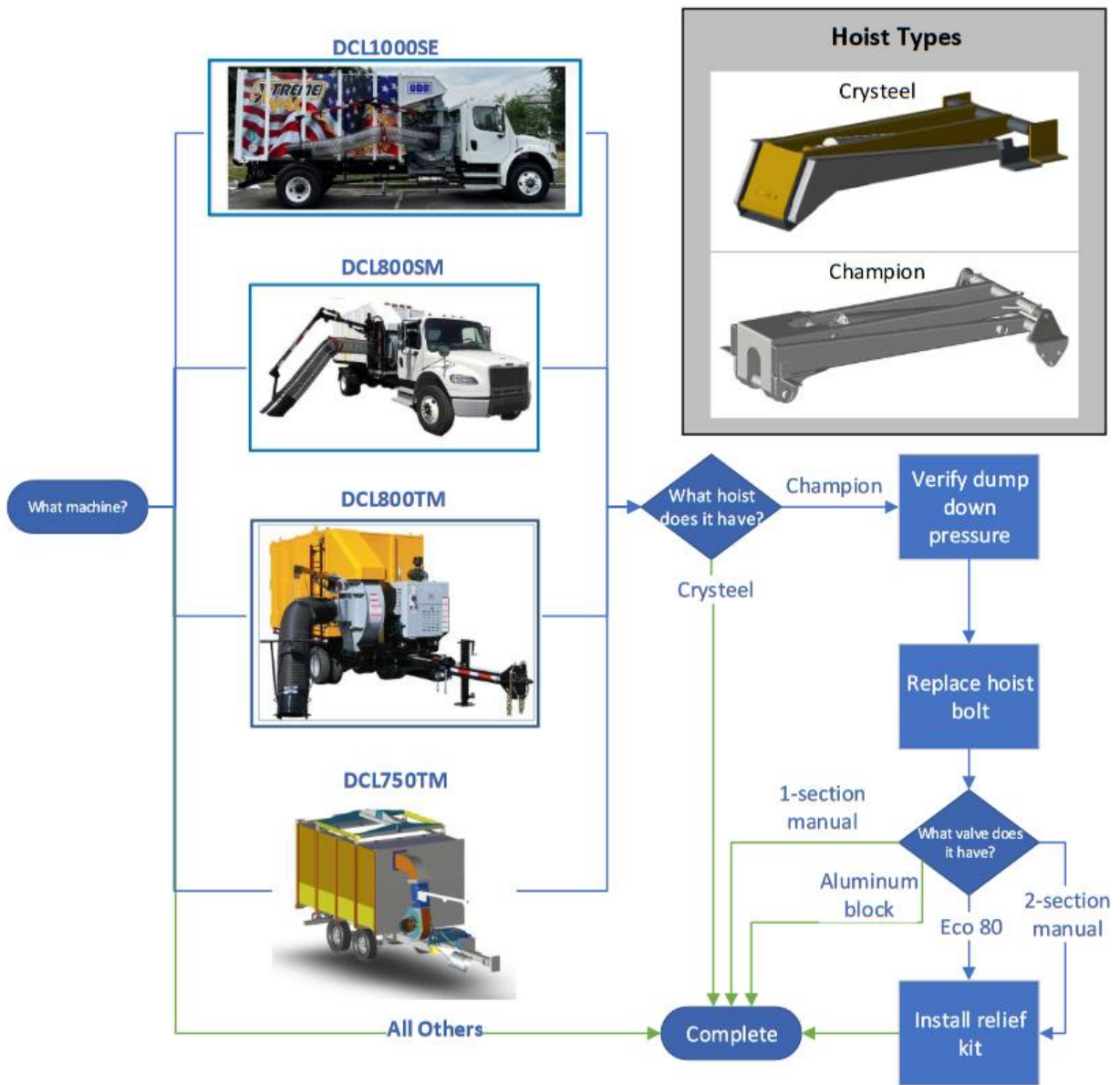

Instructions

Flowchart of required actions:





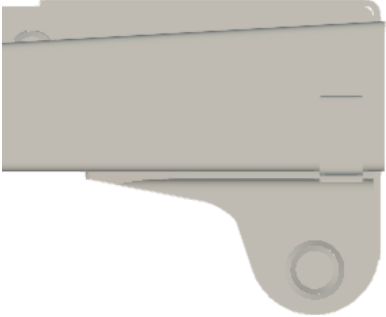
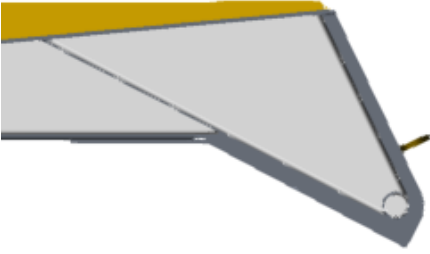
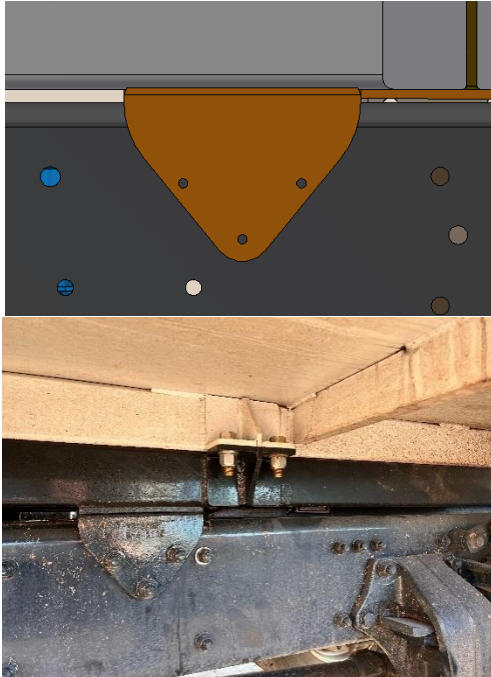
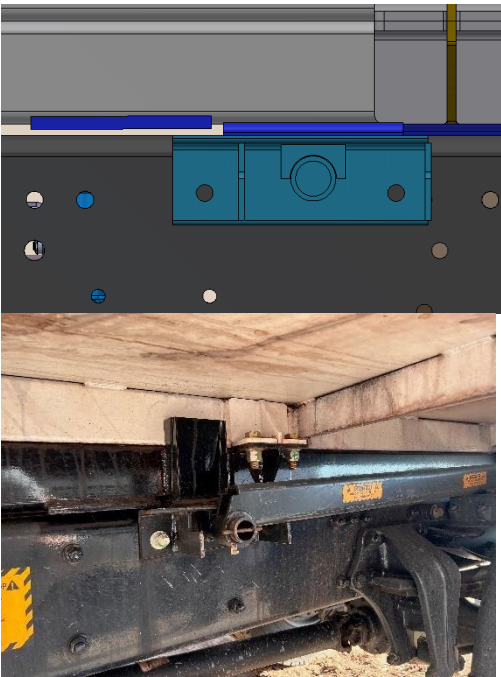

Instructions

Hoist Identification:

Check	Champion Hoist	Crysteel Hoist
Cylinder nameplate (located on the side of the mechanism)		
Rear end of hoist (nearest box hinge)	<p>The end of the Champion hoist is round on the bottom.</p> 	<p>The Crysteel hoist is angular on the bottom.</p> 
Hoist mounting points	<p>The Champion hoist mounting point is triangular. The body prop is separate from the hoist mount.</p> 	<p>The Crysteel mount point is rectangular. The body prop is integrated into the hoist mount.</p> 

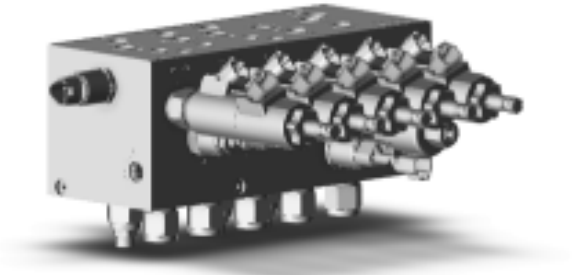
Instructions

Valve Identification:

Valve	Picture
Aluminum block	 A photograph of a rectangular aluminum block valve. It has a silver-colored body with a black top plate. On the right side, there are several hydraulic ports with silver-colored fittings. On the left side, there is a single black hydraulic port. The valve is shown from a three-quarter perspective against a white background.
1-section manual	 A photograph of a 1-section manual valve. It is a black, compact hydraulic valve with a single black handle on top. The valve is resting on a light-colored, textured surface.
Eco 80	 A photograph of an Eco 80 valve. It is a black hydraulic valve with multiple ports on top. The valve is mounted on a white rectangular base. The background is dark and indistinct.
2-section manual	 A photograph of a 2-section manual valve. It is a black hydraulic valve with two black handles on top. The valve is resting on a light-colored, textured surface.

Parts Required:

Part Number	Qty	Description
2925XZ	1	KIT,HOIST RELIEF
2926XZ	1	VALVE,INLINE,RELIEF
2927XZ	1	PLT,RELIEF VALVE MOUNT
2928XZ	1	BOLT,CHAMPION HOIST CYLINDER
2929XZ	1	HYD,FITTING,8 R5OX
2930XZ	1	HYD,FITTING,8 S5OX
2933XZ	2	HYD,FITTING,8 C6X
2934XZ	1	LINE BODY,2 WAY,SLOT MOUNTS
2936XZ	1	HOSE,DUMP,EXTEND WHIP
2937XZ	1	HOSE,DUMP,RETRACT WHIP
2941XZ	1	PLT,BOX,COVER FOR DRILLED HOLE
2942XZ	1	DECAL,DO NOT CHANGE RELIEF
	1	5/8" nylock nut
	2	M8 x 30 mm bolts
	2	1/4" x 2" bolts
	6	1/4" x 1-1/4" bolts
	16	1/4" flat washers
	8	1/4" nylock nuts
	4	1/4" sheet metal screws
	4	1/4" rivets

Tools Required:

- Drill
- 5/16" drill bit
- Torque wrench (35-40 ft-lbs/47-54 Nm capable)
- Open-end wrenches
- Ratchet wrench
- Sockets
- Hex wrenches
- Oil drip pan
- Oil-absorbent pads
- Tape measure
- 2" hole saw
- 46W hydraulic oil (around 2 gallons)

Actions Required:

Before performing any service, always follow applicable safety precautions. Consult company safety manual or supervisor for questions concerning safety.

If your unit has a Crysteel hoist, as determined above, it may return to service at this time.

Verify dump down pressure

1. Using a pressure gauge capable of reading up to 3000 psi, measure the pressure generated by the dump down function when the bed is completely down.
2. If the pressure recorded is above 800 psi, contact ODB Engineering immediately for evaluation of the hydraulic system.

Replace Champion hoist bolt

WARNING

DO NOT ACTUATE DUMP TO ACCESS HOIST

Hoists with a broken bolt may lower the box suddenly and without warning, leading to injury or death.

1. Ensure the box is lowered completely. Lower the box with a crane or fork lift if the box is stuck up for any reason.
2. Remove the bolt connecting the cylinder to the hoist mechanism. Discard the nut and bolt.

WARNING

Do not reuse the existing bolt. Using a damaged bolt could cause the hoist to fail, causing injury or death. Even if the bolt appears to not be damaged, it could fail.

WARNING

Do not reuse the existing nylock nut. Extended use or repeated installations of nylock nuts can cause the nylon locking mechanism to loosen, reducing the security of the joint.

3. Replace the bolt and nut connecting the cylinder to the hoist mechanism (**2928XZ**). Torque the nut to 106 ft-lbs (lubricated) or 212 ft-lbs (non-lubricated).
 - a. It may be necessary to cut a hole in the box to access the top of the hoist and install the bolt. Cut a 2" hole in the floor of the box.

Instructions

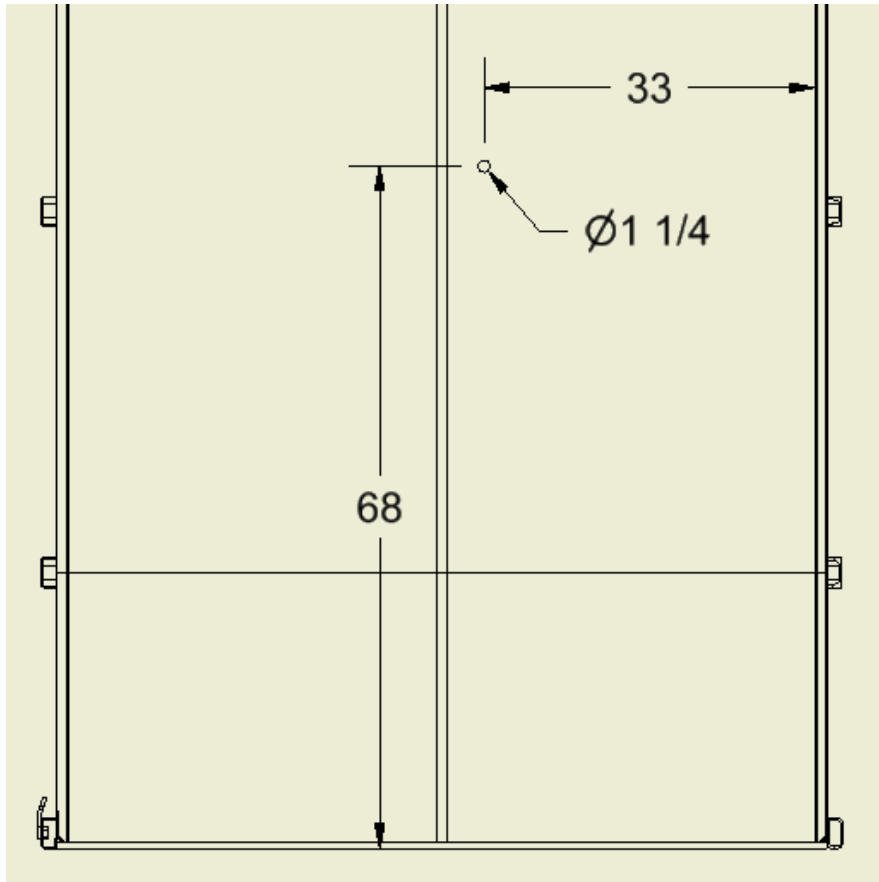

Hole dimensions. The rear of the box is down. The door is not shown.

- i. For the DCL1000SE25, the hole should be 68" from the rear sill of the box and 33" from the curb side wall of the box.
- b. Use the patch plate (**2941XZ**) to cover hole after bolt has been replaced. Secure the patch plate with sheet metal screws, bolts or rivets.

If your unit has the aluminum block valve, or the 1-section manual valve, as determined above, it may return to service at this time.

Install relief kit

1. Clean any debris off the control valve. Allow the valve to dry completely.
2. Mount the relief valve and bracket (**2926XZ, 2927XZ, 2929XZ, 2930XZ, 2933XZ, 2934XZ**) to the machine, between the control valve and the hoist cylinder. Refer to the following table for location based on model.

Instructions

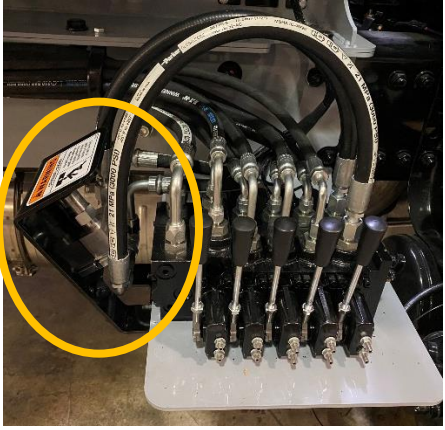
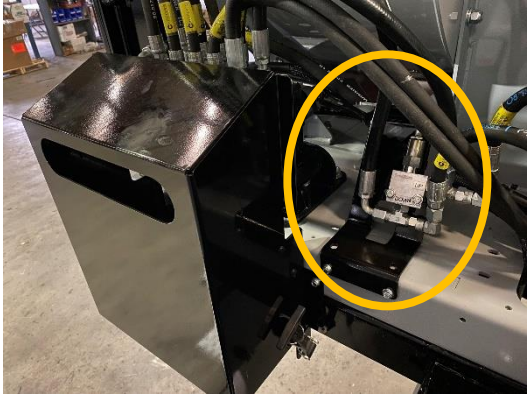
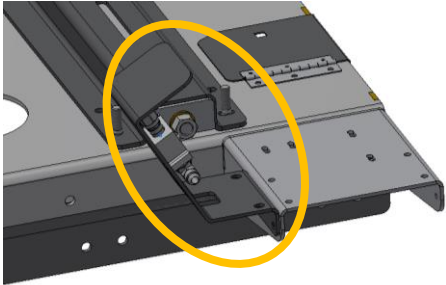
Model	Install Location	Installation Notes	Picture
DCL1000	To the left of the valve, when looking from the side of the machine.	<p>The bracket shares the two rear bolts securing the valve. Only the holes closest to the relief valve will be used.</p> <p>Replace the two M8 bolts that the valve bracket will mount to with the M8 x 30 bolts in this kit.</p>	
DCL800SM	To the right of the valve, when looking towards the rear of the machine.	The bracket attaches to two holes on the front of the skid. Only the holes on the short flange will be used.	
DCL800TM	On the left side of the valve bracket, when looking from the tongue.	Match drill (2) 5/16" holes in the left side of the existing bracket for the relief bracket.	

Instructions

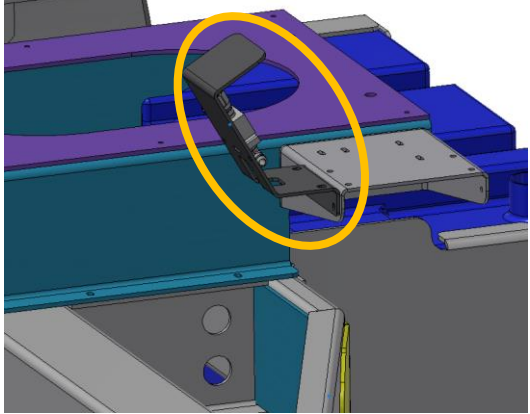
Model	Install Location	Installation Notes	Picture
DCL750	On the left side of the valve bracket, when looking from the tongue.	Match drill (2) 5/16" holes in the left side of the existing bracket for the relief bracket.	

3. Apply the decal (**2942XZ**) to the long flange on the top of the bracket.

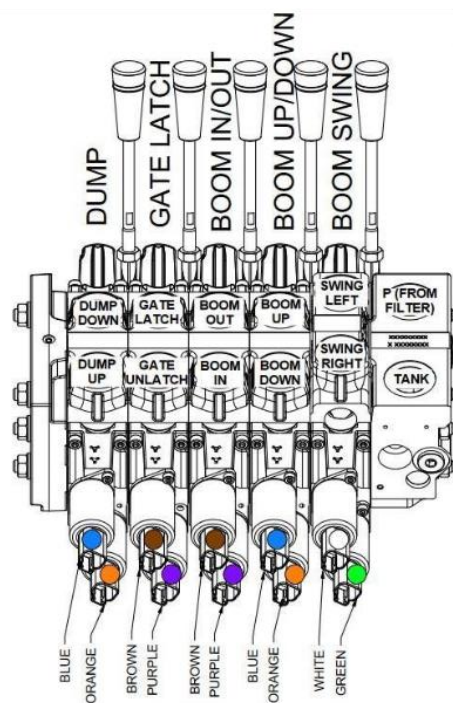

The Eco 80 control valve, as seen from the wire side. The dump section is on the far left. Verify hose routing before proceeding.

4. Identify the dump up and dump down hoses by tracing them back from the cylinder. Mark each hose to indicate which side of the cylinder it is connected to.
5. With the truck and auxiliary engine off (if applicable), release hydraulic pressure from the dump section by manually actuating the dump section of the valve (found in Step 4) in both directions. Hold the lever fully in each direction for at least 10 seconds to ensure that all pressure has been relieved from the hoses.

Instructions

- a. For the Eco 80 valve, install a valve handle or use a 9 mm wrench to manually actuate the valve.
6. Install a drip pan beneath the control valve to catch oil.
7. Remove the dump hoses from the valve. Slide the hoses away from the valve through the zip ties so the fittings are closer to the relief valve.

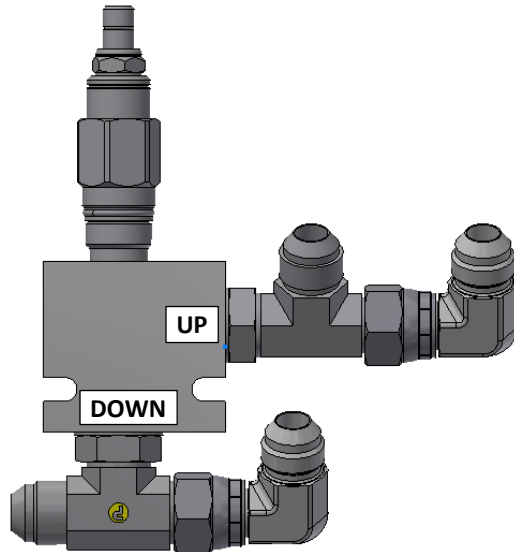

The relief valve, with fittings. The fittings on the right are the “UP” side and is stamped with a 2; the fittings on the bottom are the “DOWN” side and is stamped with a 1.

8. Install the dump up (extend) hose to the tee fitting on the side of the valve marked “UP.”
9. Install the dump down (retract) hose to the tee fitting on the side of the valve marked “DOWN.”

Instructions



10. Install the dump up hose jumper (**2931XZ**) from the tee fitting on the side of the valve marked "UP" to the control valve and install on the port that the dump up hose was removed from.
11. Install the dump down hose jumper (**2932XZ**) from the tee fitting on the side of the valve marked "DOWN" to the control valve and install on the port that the dump down hose was removed from.



12. Slide any loose hose loops back into the skid and secure away from any moving parts.

Instructions

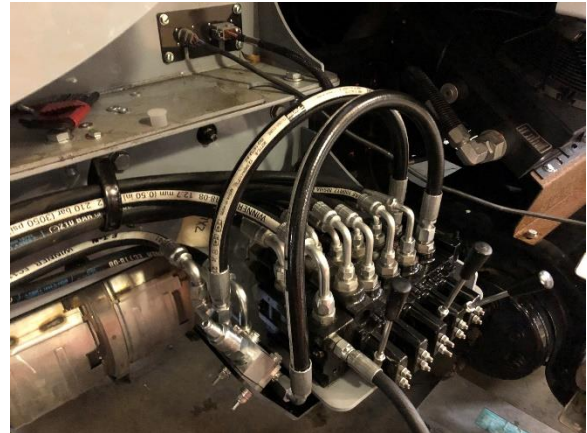
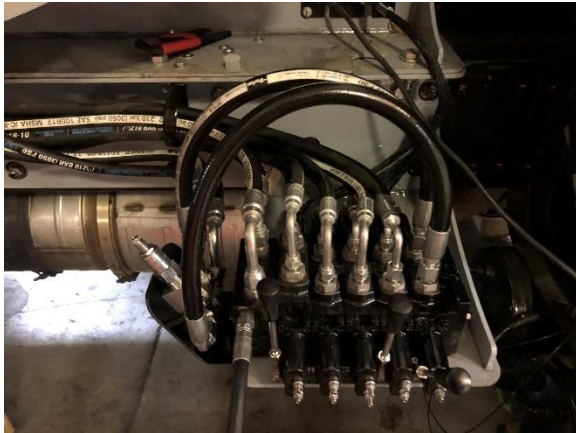

13. Ensure proper oil level and bleed air from all hoses by following TSB101322 DCL1000 Oil Fill.
14. Properly dispose of any oil and oil-soaked rags.

Supplemental Materials

Valve Body and Fitting Installation

General Arrangement:

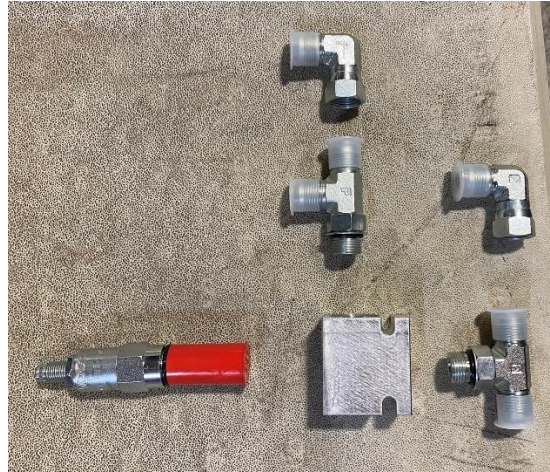

Clamp the body in a vise, with the valve port facing up. The valve port has a dot next to it.



Install valve cartridge with a 1 in wrench and torque to 35-40 ft-lbs (47-54 Nm).



Supplemental Materials

Mark the valve body and cartridge with a line of cross check or a paint pen.



Loosen the adjustment jam nut with a 3/4 in wrench and unscrew the adjustment screw with a 3/16 in hex wrench until it stops.



Turn the adjustment screw in 3 full turns. Tighten the jam nut while holding the adjustment screw.

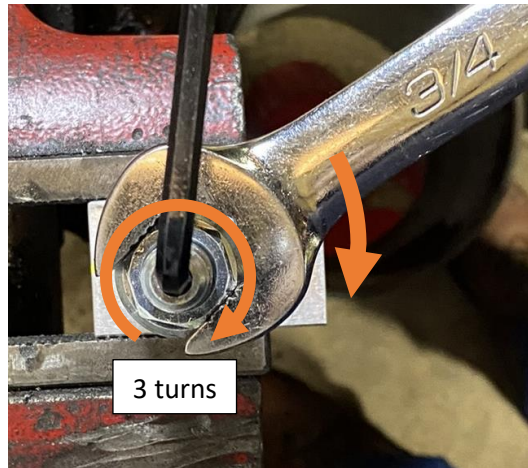

Supplemental Materials

Mark the cartridge threads and body with a line of cross check or a paint pen.



Thread the branch tee in to the port marked 1.

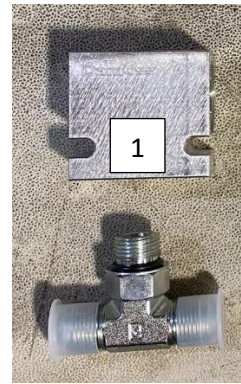

Thread the run tee in to the port marked 2.



Supplemental Materials

Thread the 90-degree fittings on the right sides of the tees.



Angle the side ports (tees and 90s) 30 degrees up.

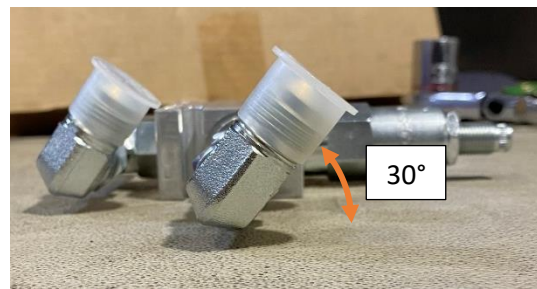

Tighten all fittings, holding each fitting as it is tightened to maintain the angles.