

January 18, 2024

Version 2

**Safety Recall: 2018–20 Civic Fuel Pump Motor (Except VINs Starting with JHM)**

Supersedes 24-008, dated January 17, 2024, to revise the information highlighted in yellow.

**AFFECTED VEHICLES**

Year	Model	Trim Level	VIN Range
2018–20	Civic 2-Door	All except Si	Check the iN VIN status for eligibility.
2018–19	Civic 4-Door	All except Si	Check the iN VIN status for eligibility. (Except VINs Starting with JHM)
2018–20	Civic 5-Door	All except Si and Type R	Check the iN VIN status for eligibility.

**REVISION SUMMARY**

Under AFFECTED VEHICLES, Vehicles and VIN range was updated.

**BACKGROUND**

On December 18, 2023, American Honda notified NHTSA of its intention to initiate a **STOP SALE** and **safety recall** for a certain number of 2018–20 Civic units in order to replace the fuel pump motor manufactured with defective impellers.

Due to swelling of the fuel pump motor impeller, the fuel pump may seize and stop working. A defective impeller may cause the fuel pump to become inoperative, which could prevent an engine from functioning as intended. This limitation may cause a loss of motive power or a stall while being driven, increasing the risk of a crash or injury, creating a safety hazard.

If this bulletin appears during an iN VIN status inquiry, the vehicle is subject to a **safety recall**. Any affected vehicles in your dealer inventory are on **STOP SALE** until further notice. Refrain from calling Tech Line for updates.

**CUSTOMER NOTIFICATION**

Owners of the affected vehicles will be sent a notification of this campaign. They will be informed that due to a limited supply of parts (at this time) Honda is **prioritizing** the repair of customer vehicles experiencing symptoms related to this recall.

When **adequate replacement parts** become available, Honda will send a follow-up letter to customers instructing them to schedule an appointment for all vehicles affected by this recall. If a customer experiences the known symptoms associated with this **safety recall** (see CORRECTIVE ACTION), they are instructed to contact their local Honda dealer for the repair.

For any questions or concerns customers may have, you may have them contact American Honda Customer Support & Campaign Center at **1-888-234-2138**.

The following suggested text should be included on any repair order for an already sold affected vehicle that comes in for service. This information should be printed out completely any time service is conducted on an affected vehicle, and the recall repair has not yet been completed. Depending on parts availability, the normal procedures under SOM 7.2.1 will apply for this recall.

**CUSTOMER INFORMATION:** The information in this bulletin is intended for use only by skilled technicians who have the proper tools, equipment, and training to correctly and safely maintain your vehicle. These procedures should not be attempted by “do-it-yourselfers,” and you should not assume this bulletin applies to your vehicle, or that your vehicle has the condition described. To determine whether this information applies, contact an authorized Honda automobile dealer.

## Suggested Verbiage to be Included on the Repair Order

Customer was advised that:

The vehicle is subject to a recall affecting the fuel pump motor. The parts necessary to complete the recall repair are currently limited. Vehicles with eligible VINs and the following symptoms: difficulty starting, engine hesitation while driving, and/or an illuminated check engine light displayed with DTC P0087, are eligible for immediate repair. Once parts repair kits are available, if the vehicle has not been repaired, the registered owner of the vehicle will receive a notice to bring the vehicle in for a replacement of the components, regardless of symptom.

## IMPORTANT NOTICE

Vehicles that are **both** shown as an eligible VIN and experiencing the following symptoms will be **prioritized** for repair: difficulty starting, engine hesitation while driving, and/or an illuminated check engine light displayed with DTC P0087 (Fuel Rail Pressure Too Low) stored.

## CORRECTIVE ACTION

Replace the fuel pump motor.

NOTE: If the vehicle has any of the symptoms listed in BACKGROUND, you must apply this bulletin before attempting any other repairs. If the symptoms remain after the recall repair is complete, only attempt further repairs (such as replacing the high-pressure fuel pump) after authorized troubleshooting.

## PARTS INFORMATION

NOTE:

- Due to a limited supply, parts will be allocated to your dealership **based on availability**.
- Prioritize repairing customer vehicles that meet both the VIN status eligibility and exhibit a known symptom such as: difficulty starting, engine hesitation while driving, and/or an illuminated check engine light with DTC P0087 (Fuel Rail Pressure Too Low).

Part Name	Part Number	Quantity
Fuel Pump Motor Kit	06170-TBA-306	1

**For dealers experiencing a strong fuel smell from storing a fuel pump motor replaced under this service bulletin,** the fuel pump motor may be disposed of immediately in accordance with local regulations. This only applies to the fuel pump motor replaced under this service bulletin. The published retention policy remains in effect for all other parts.

If you have any questions about this exception or other parts retention issues, contact the WPI Administrative Office at **937-642-2737**.

## TOOL INFORMATION

Tool Name	Part Number	Quantity
Fuel Sender Wrench	07AAA-TBAA100	1
ORVR Service Plug	07AAK-TBAA100	1

## WARRANTY CLAIM INFORMATION

Operation Number	Description	Flat Rate Time	Defect Code	Symptom Code	Template ID	Failed Part Number
3101EH	<b>2- and 4-door</b> - Replace the fuel pump motor, and do the VSA sensor neutral position memorization procedure.	1.3 hr	6FE00	MGJ00	A24008A	17045-TBA-A00
	<b>5-door</b> - Replace the fuel pump motor, and do the VSA sensor neutral position memorization procedure.	1.4 hr			A24008B	

Skill Level: Repair Technician

## REPAIR PROCEDURE

### ⚠ WARNING

Fuel pump motor removal exposes fuel, which can ignite, causing a fire or explosion.

This can cause serious injury or death.

Always work in a well-ventilated area and keep sparks or open flames away.

1. Insert the emergency fuel fill funnel into the fuel filler neck to relieve the pressure in the fuel tank.

NOTE: The emergency fuel fill funnel is in the trunk tool box.

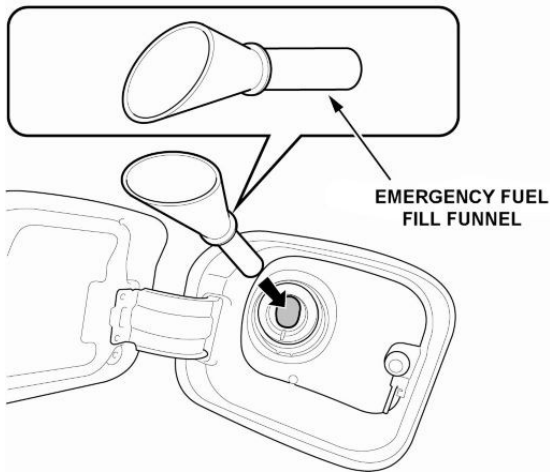

2. Remove the PGM-FI main relay 2.

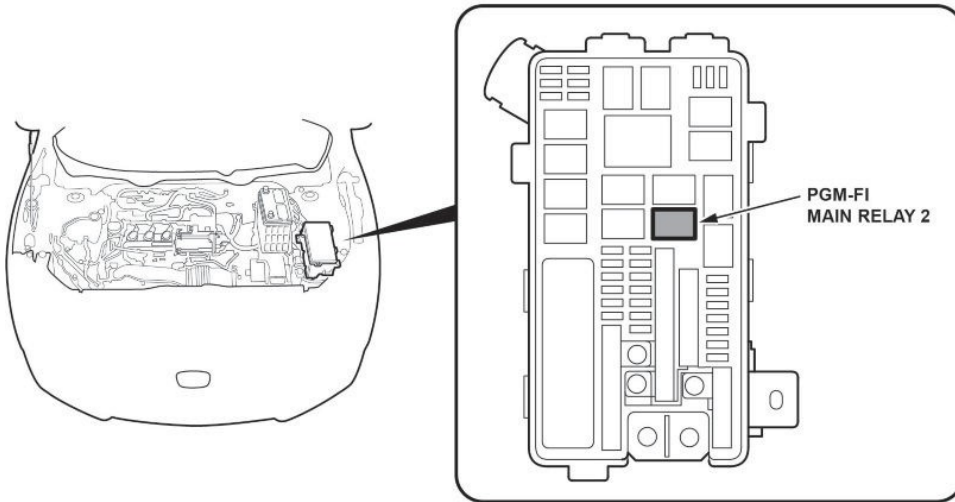

3. Start the engine, and let it idle until it stalls.
4. Turn the ignition to OFF.
5. Install the PGM-FI main relay 2.
6. Disconnect both 12-volt battery terminals.

**NOTICE**

To protect the terminal connector from damage, do not hold it when removing the negative terminal.

**NOTE:**

- Always disconnect the negative terminal first.
- Do not disconnect the 12-volt battery sensor from the cable.

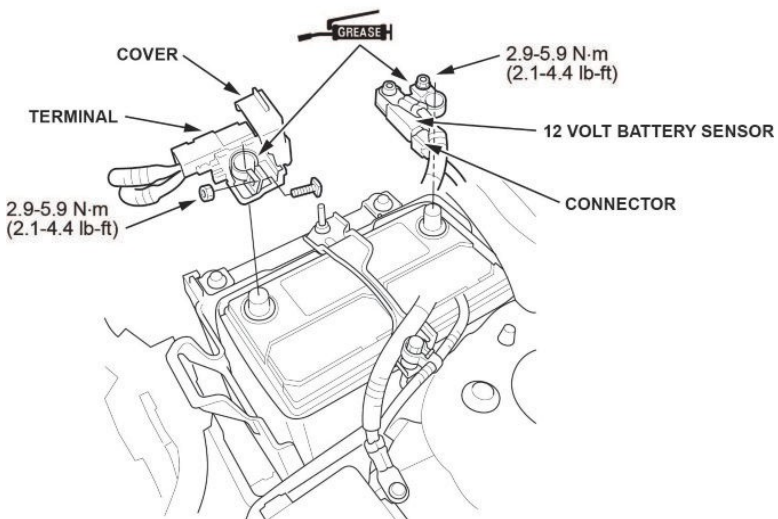

7. Remove the rear seat cushion bolt.

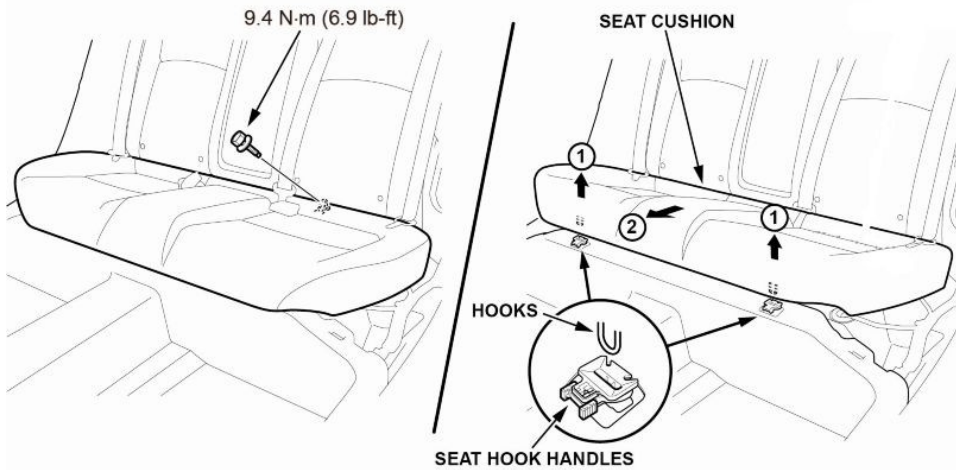

8. While pushing down on the seat cushion, pull the seat hook handles to release the hooks.
9. Remove the rear seat cushion.
10. *5-door models:* Remove both tie down hooks, then release the two clips by pulling up on the front edge of the cargo floor cover.

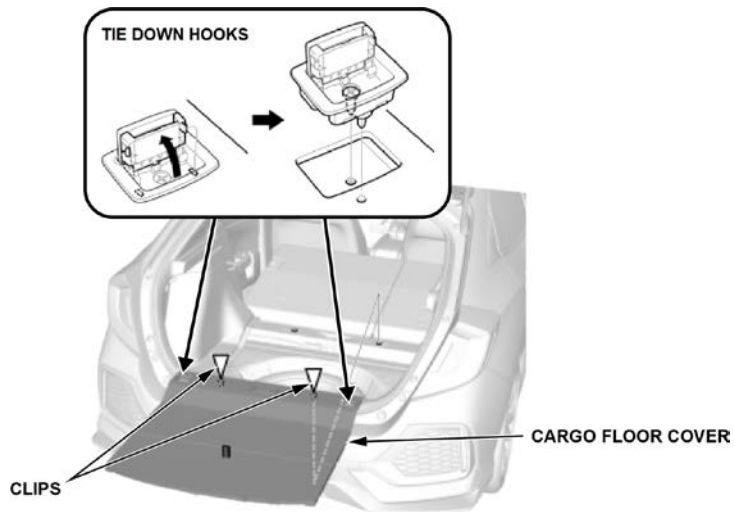

11. Fold down the right-rear seat-back.

12. Turn over the bottom of the right-rear seat-back cover, then remove the bolts.

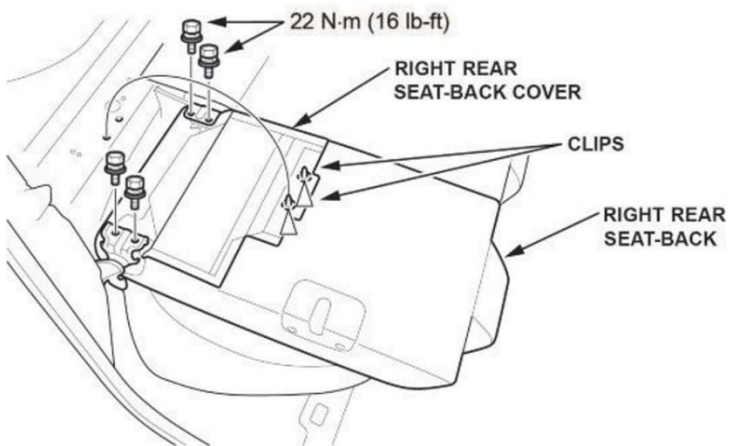

13. Remove the right-rear seat-back.

14. Fold down the left-rear seat-back.

15. Turn over the bottom of the left-rear seat-back cover, then remove the bolts.

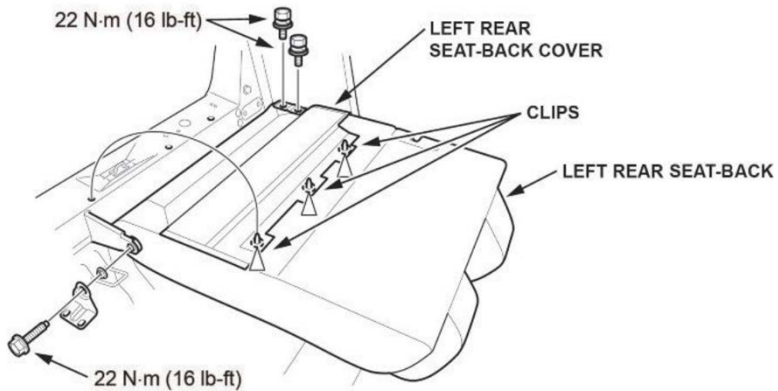

16. Remove the left rear seat-back.

17. Remove the center rear seat belt lower anchor bolt.

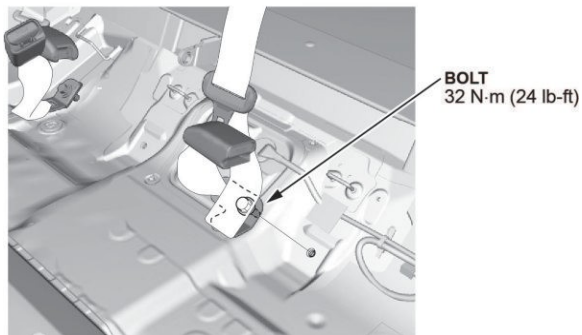

18. Remove the fuel tank unit access panel, and disconnect the connector.

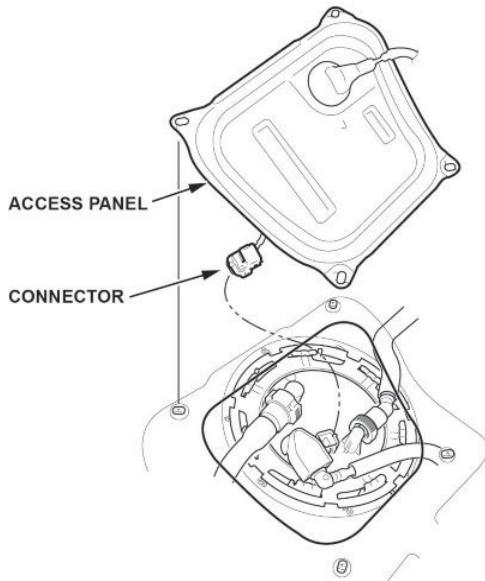

19. Lift the front of the vehicle.

**NOTICE**

If the fuel level is showing **90%** or more, the front of the vehicle must be raised more than **345 mm (13.58 in)** as shown to prevent fuel spillage when the fuel tank unit is removed. Make sure the vehicle is securely supported when raised.

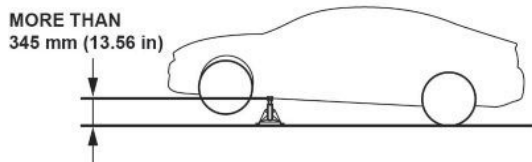

20. Disconnect the quick-connect fitting from the fuel tank unit.

NOTE: Remove the fuel connector cover if necessary.

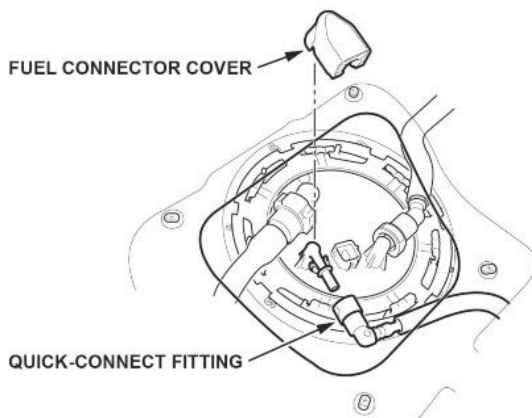

21. Unlock the fuel tank unit cam lock ring using the fuel sender wrench (T/N 07AAA-TBAA100).

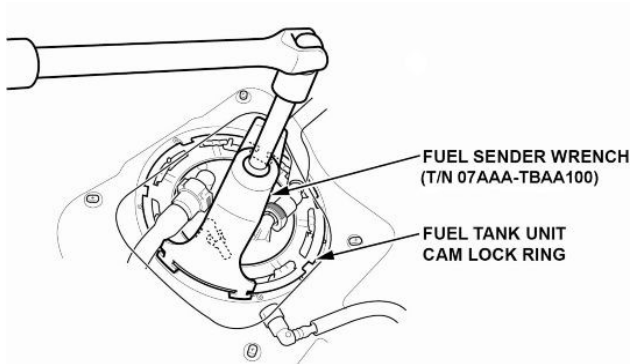

22. Set the fuel sender wrench as shown, and make sure it does not float while turning.

23. Turn the fuel tank unit cam lock ring counterclockwise.

24. Disconnect the fuel vent tube and fuel tank vapor recirculation tube.

NOTE:

- Do not bend the fuel vent tube and fuel tank vapor recirculation tube excessively. After disconnecting both tubes, rotate the fuel tank unit clockwise to fully remove them.
- Do not forcibly remove the fuel vent tube and fuel tank vapor recirculation tube. The tubes are fragile; be careful when removing them.

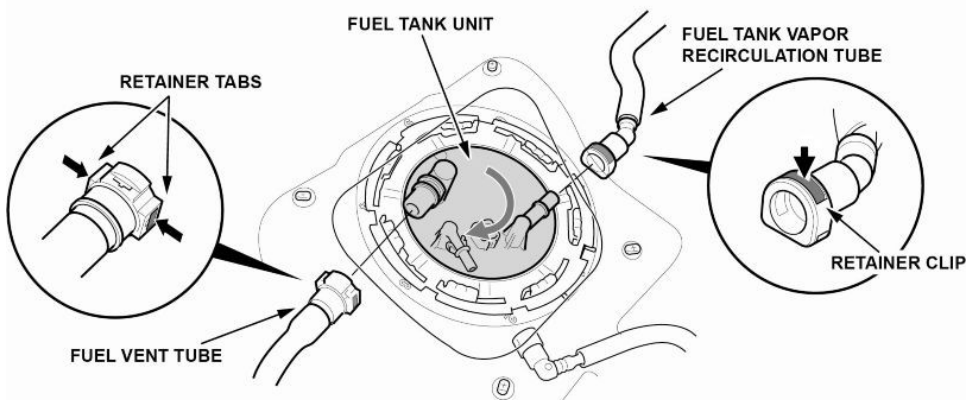

25. Hold the fuel vent tube with one hand, push the retainer tabs in **all the way** with the other hand, then disconnect the tube.

26. Push in the fuel tank vapor recirculation tube toward the fuel tank unit, push down on the retainer clip, then disconnect the tube.

27. Pull the tubes off by slightly rotating the fuel tank unit clockwise



28. Remove the fuel tank unit cam lock ring.

NOTE: After unlocking the fuel tank unit cam lock ring, clean the top of the fuel pump flange and adjacent areas to make sure it's free of dirt, dust, and debris.

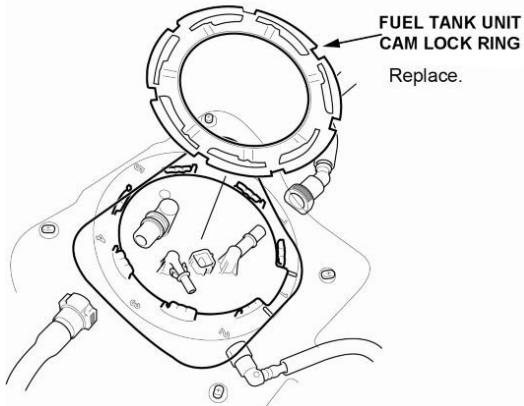

29. Partially remove the fuel tank unit.

30. Hook the clip end of the ORVR service plug (T/N 07AAK-TBAA100) lanyard on to the child safety seat hook as shown. Then, place the ORVR service plug near the fuel tank unit opening.

NOTE:

- The fuel pump motor kit includes a ORVR plug without the lanyard. It can be used in place of the ORVR service plug (T/N 07AAK-TBAA100), but only use it if ORVR service plug (T/N 07AAK-TBAA100) is unavailable or damaged. If using the ORVR plug without the lanyard, tie a wire to it so it can be tied to the child safety seat hook.
- Avoid damaging any part of the ORVR service plug's surface. Damage to the service plug may cause fuel leaks into the inner fuel vent tube. Use the provided protective cap when the ORVR service plug is not in use. If there is damage, throw away the ORVR service plug and order a new one.

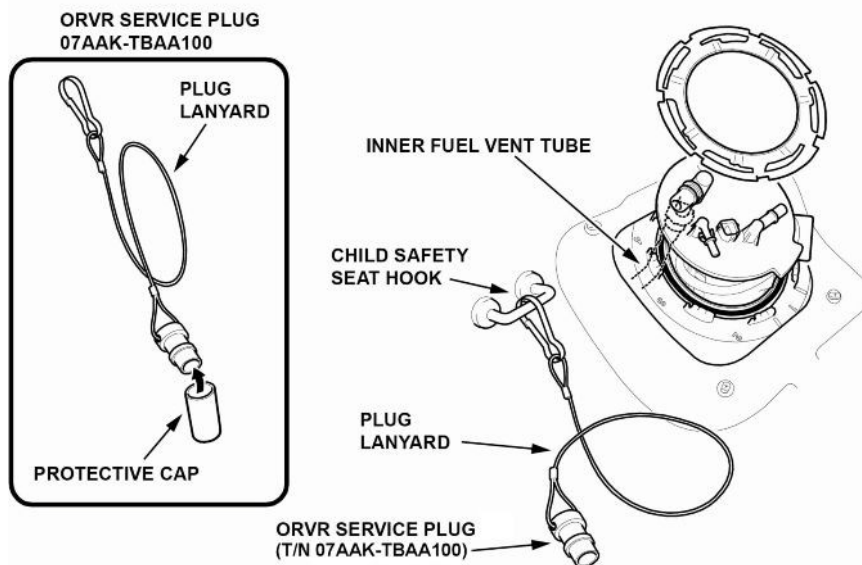

31. Disconnect the inner fuel vent tube from the fuel tank unit, and hold it.

**NOTICE**

Do not allow the inner fuel vent tube to fall inside the fuel tank before installing the ORVR service plug to it. If fuel enters the inner fuel vent tube, a DTC will set and the inner fuel vent tube will need to be replaced.

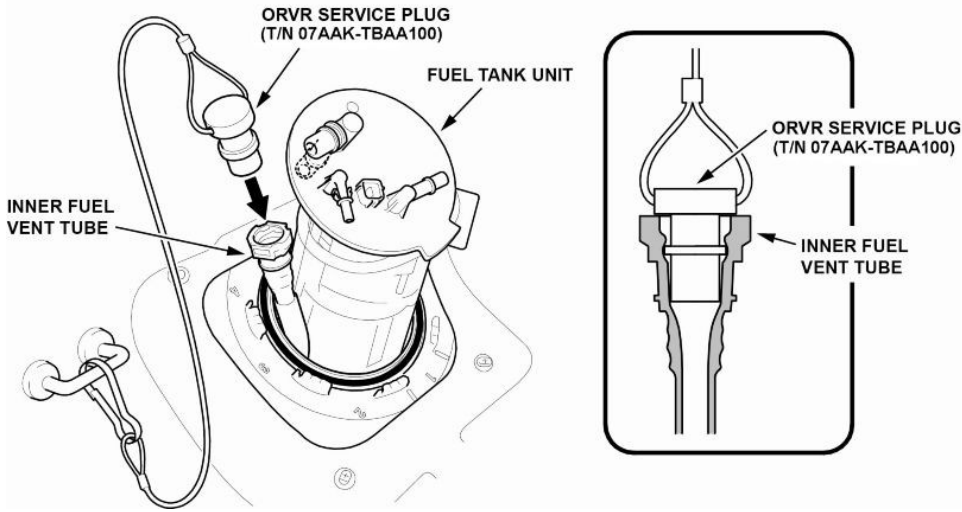

32. Install the ORVR service plug to the inner fuel vent tube. Make sure the ORVR service plug is fully seated by holding the inner fuel vent tube and gently pulling on the plug's lanyard.

NOTE: The ORVR service plug should not come off.

33. Carefully lower the inner fuel vent tube into the fuel tank while making sure the plug lanyard is free and away from the fuel tank unit.

NOTE: It is OK for the plugged tube to be submerged in the fuel.

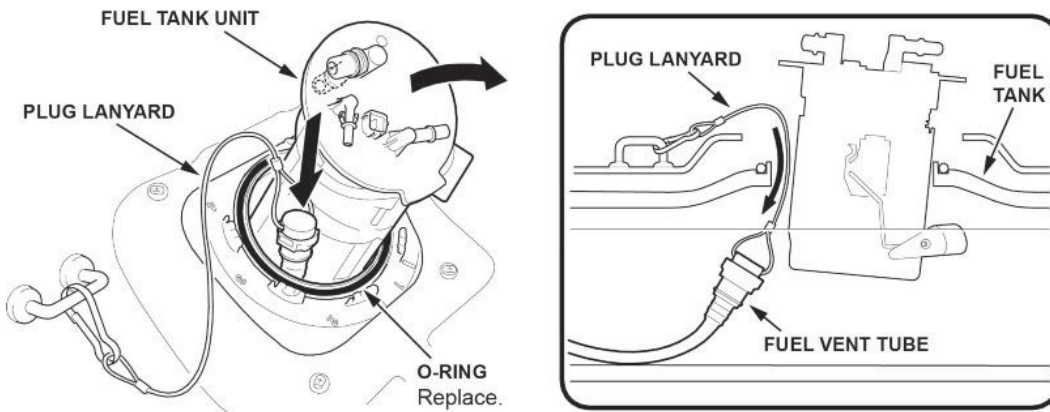

34. Remove the fuel tank unit with the O-ring.

**NOTICE**

Do not to bend or twist the fuel level sensor arm excessively. This may damage the fuel level sensor or cause it to send inaccurate readings.

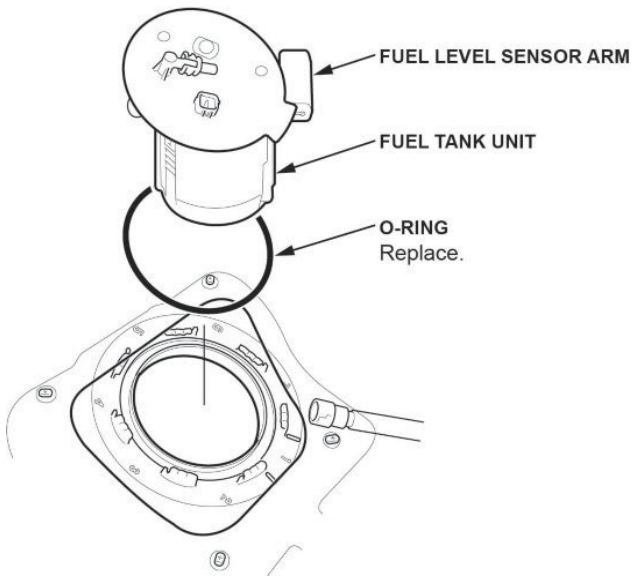

35. Prepare the fuel tank unit and parts to be replaced.

NOTE: Take a photo of the fuel tube and wire harness, and note their routing for assembly. There are various types of routing.

36. Spread the wire harness clamps, and remove the wire harness. Make sure not to damage the wire harness.

**NOTICE**

Do not spread the clamps too wide. Spreading them too wide may damage them.

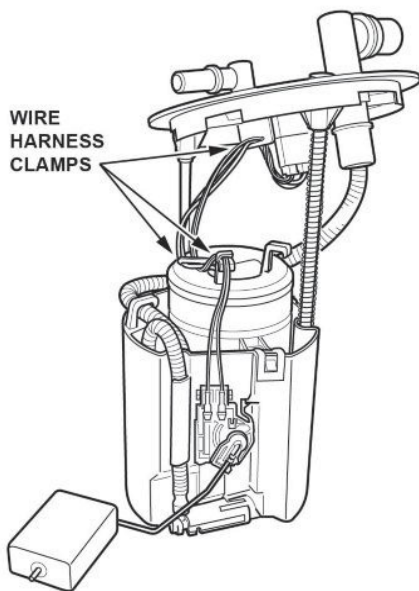

37. Press the tab on the fuel level sensor to release the lock. Then, push up on the fuel level sensor.

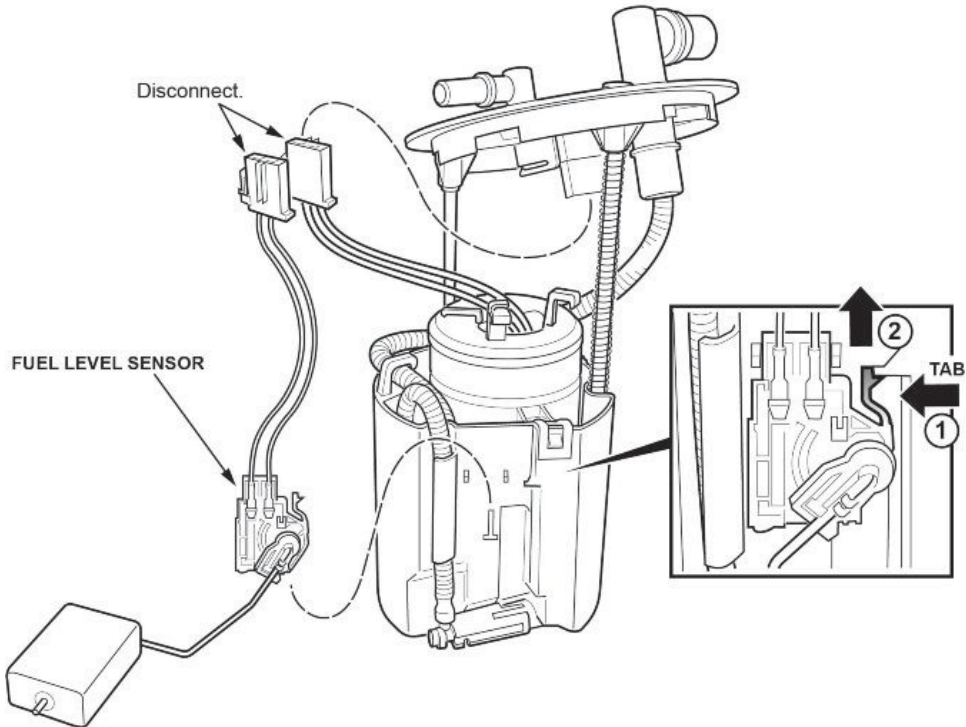

38. Disconnect the fuel level sensor harness and remove the fuel level sensor from the fuel tank unit.

39. Remove the E-ring, and discard it.

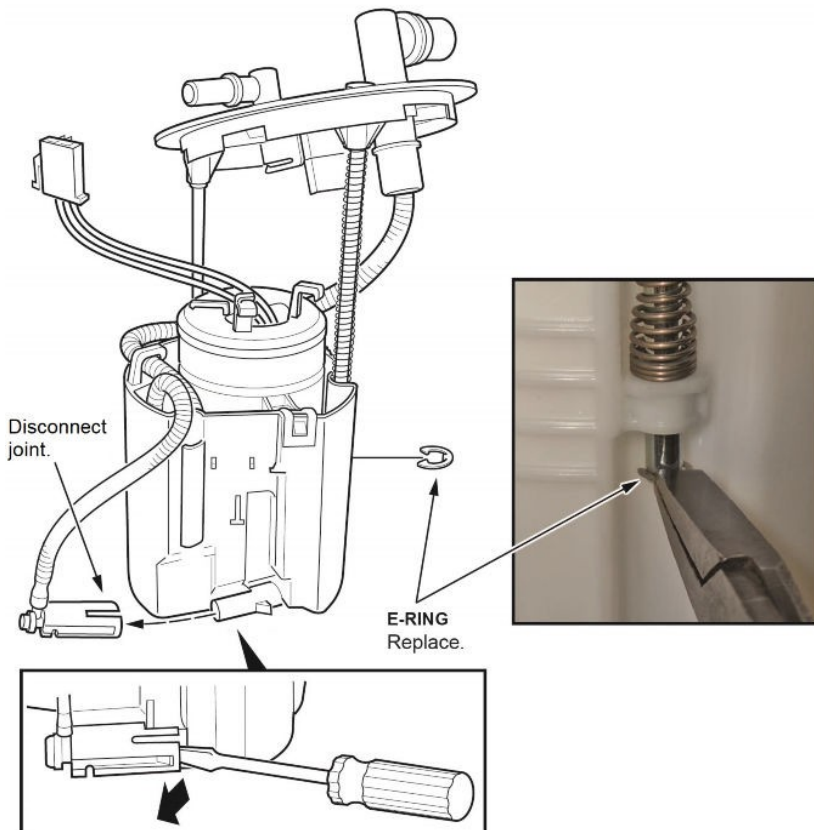

40. Disconnect the joint at the bottom of the reservoir.
41. Remove the fuel filter assembly from the reservoir by releasing the three clips.

**NOTICE**

Do not spread the clips too wide. Spreading them too wide may damage them.

NOTE: The spring may slide off the sliding shaft. Retain this spring. It will be used during assembly.

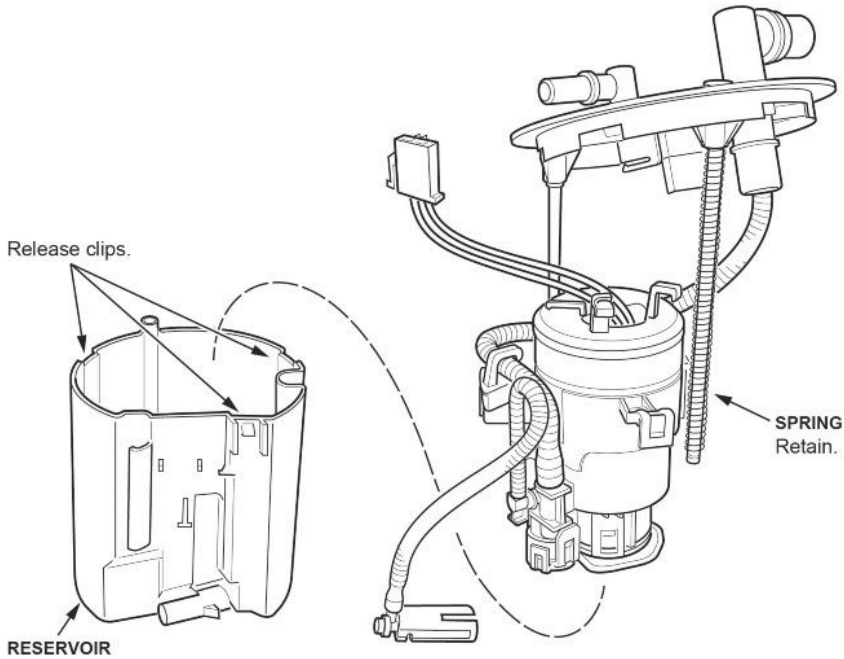

42. Release the three clips at the base of the fuel pump assembly and remove it from the fuel filter.

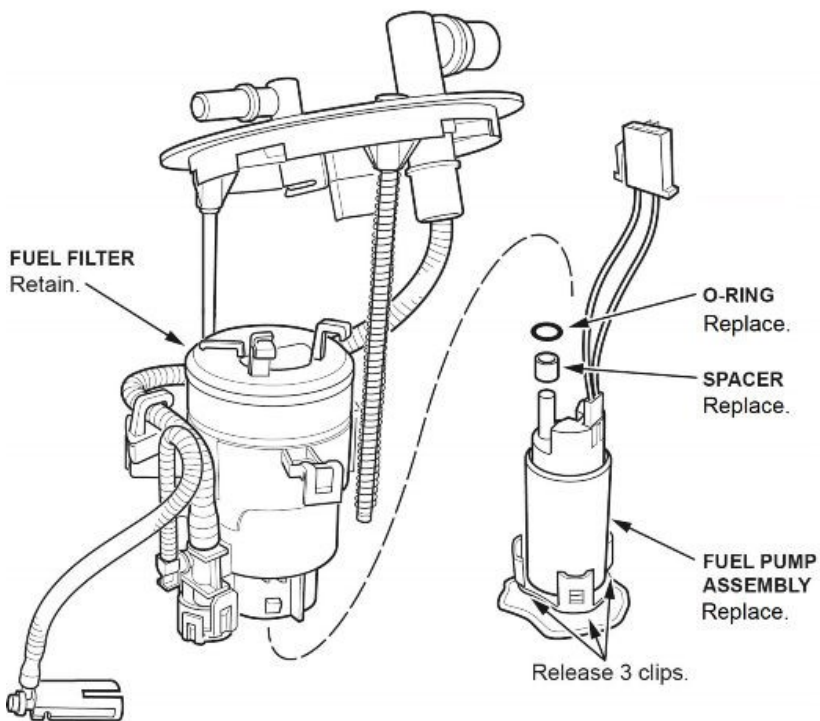

43. Install the new spacer onto the new fuel pump motor.

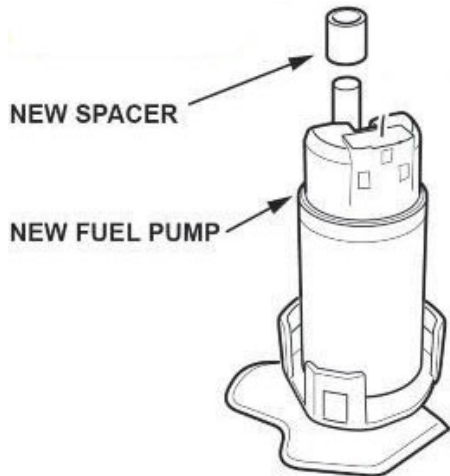

44. Install the new O-ring, then lubricate ONLY the outside edge of it, using clean engine oil.

NOTE: Do not pinch the O-ring during installation.

**NEW O-RING**

Lubricate after installing.

Do not lubricate the inside of the o-ring.

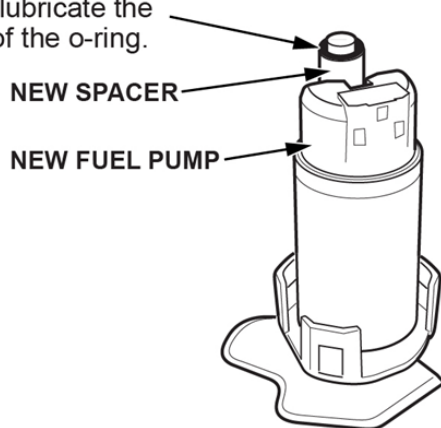

45. Install the new harness making sure the connection is secure and the connectors are firmly locked into place.

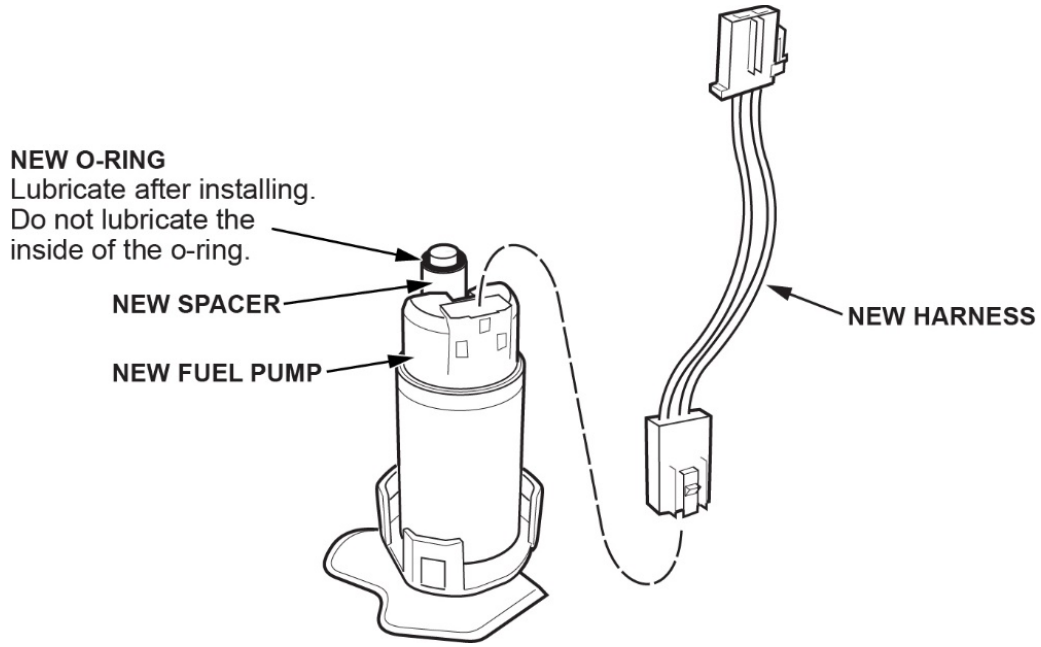

46. With the palm of your hands press the fuel pump into the suction fuel filter.

Click here to view video:

[▶ PLAY VIDEO](#)

**NOTICE**

When pressing the fuel pump into the suction filter make sure you do so with a single firm push. Failure to do so may damage the O-ring. If it is seated properly, you will hear a click.

If you do not hear the click, remove all parts and inspect the O-ring for damage. If the O-ring is damaged, it must be replaced. Reassemble using the above process.

**NOTE:**

- When inserting the pump, be careful not to break the suction filter.
- If the O-ring is damaged; replace it with a new one.
- After installing the fuel pump to the suction filter, make sure the clips are firmly attached to the new fuel pump.

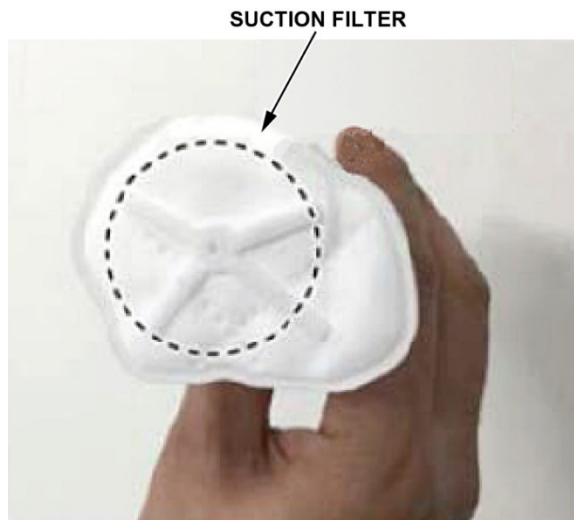

**GOOD**

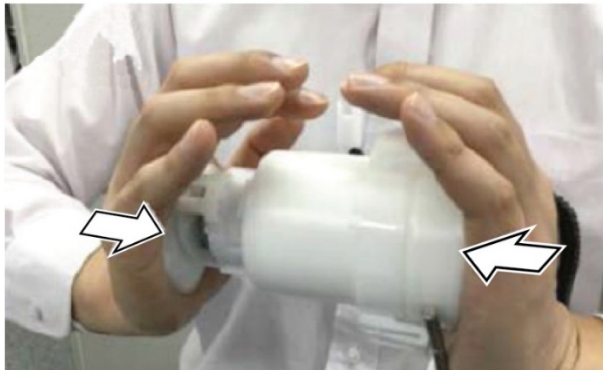

**NO GOOD**





47. Install the fuel filter assembly to the reservoir.

NOTE:

- Insert the spring into the sliding shaft, and make sure it is lined up when installing the fuel filter.
- Make sure to route the fuel tube **exactly** as shown in the photo taken before disassembly.
- Make sure the three clips are fully engaged.

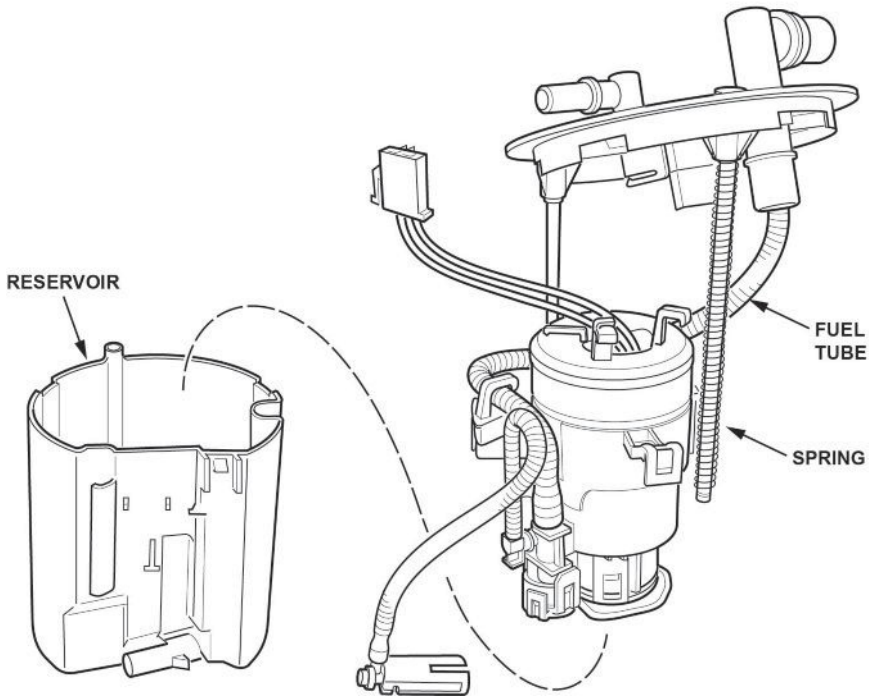

48. Install the new E-ring.

NOTE: After installation, make sure the E-ring can be rotated with your finger. If it cannot be rotated, the E-ring may not be fully seated or may be incorrectly installed.

49. Install the fuel level sensor to the reservoir. Make sure the lock is engaged and the connection is secure.

NOTICE

Do not to bend or twist the fuel level sensor arm excessively. This may damage the fuel level sensor or cause it to send inaccurate readings.

50. Install the wiring harness to the clamps.

**NOTICE**

Do not spread the clips too wide. Spreading them too wide may damage them.

**NOTE:**

- Clip in the smaller harness wires followed by the larger wires.
- Make sure not to damage the wire harness.
- Make sure to route the wire harness **exactly** as shown in the photo taken before disassembly.

**HARNESS ROUTING:**

Clip in the smaller harness wires followed by the larger wires.

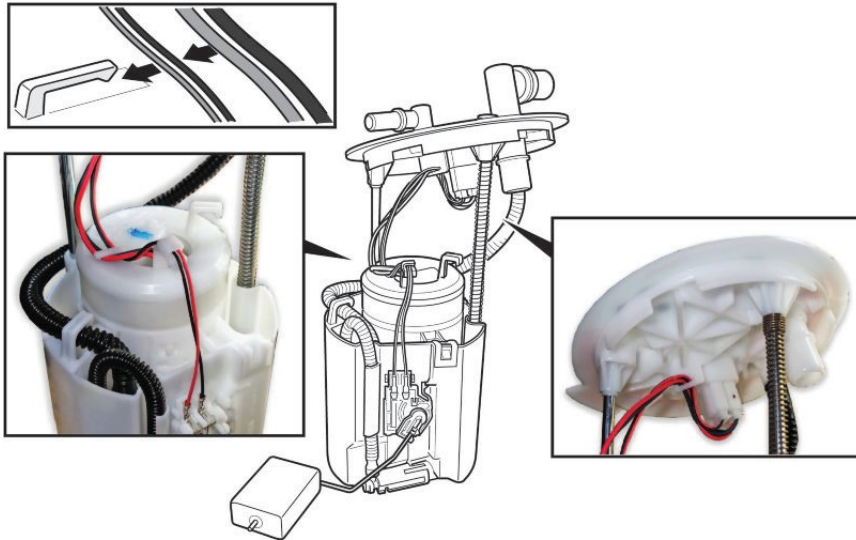

51. While compressing the fuel tank unit, make sure the movement is smooth and the fuel tube and wiring harness do not stretch, pinch, or bind.

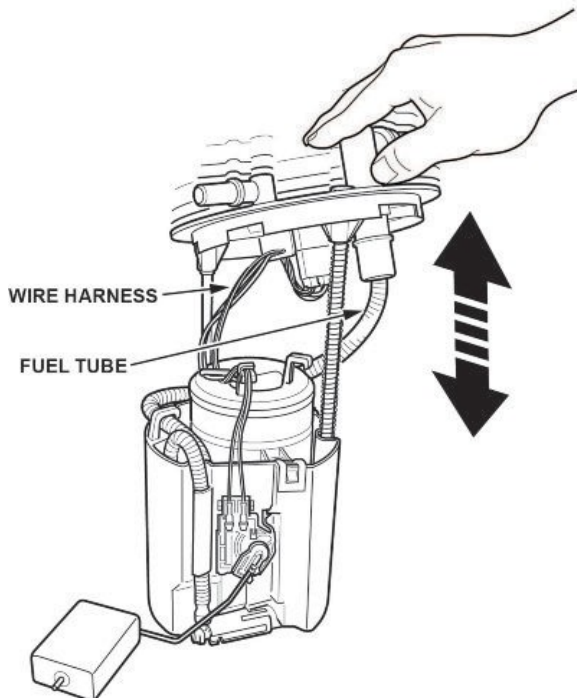

52. Install a new O-ring on the fuel tank.

**NOTE:**

- Before installing the new O-ring, clean the fuel tank around the fuel pump opening where the O-ring will seat. The tank opening must be free of dirt, dust, and debris.
- Be careful not to damage the O-ring.
- Do not coat the O-ring with any oil.

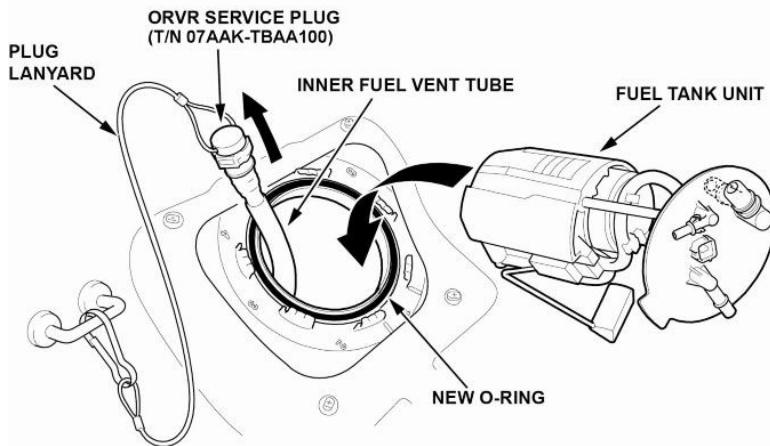

53. Grab the plug lanyard, and pull the inner fuel vent tube up until it is close to the fuel tank opening. Hold the tube while installing the fuel tank unit.

54. Move the fuel tank unit aside, and remove the ORVR service plug from the inner fuel vent tube.

**NOTICE**

Do not allow the inner fuel vent tube to fall inside the fuel tank before installing the ORVR service plug to it. If fuel enters the inner fuel vent tube, a DTC will set and the inner fuel vent tube will need to be replaced.

55. Move the ORVR service plug away from the tank opening, and connect the inner fuel vent tube to the fuel tank unit.

**NOTICE**

Do not to bend or twist the fuel level sensor arm excessively. This may damage the fuel level sensor or cause it to send inaccurate readings.

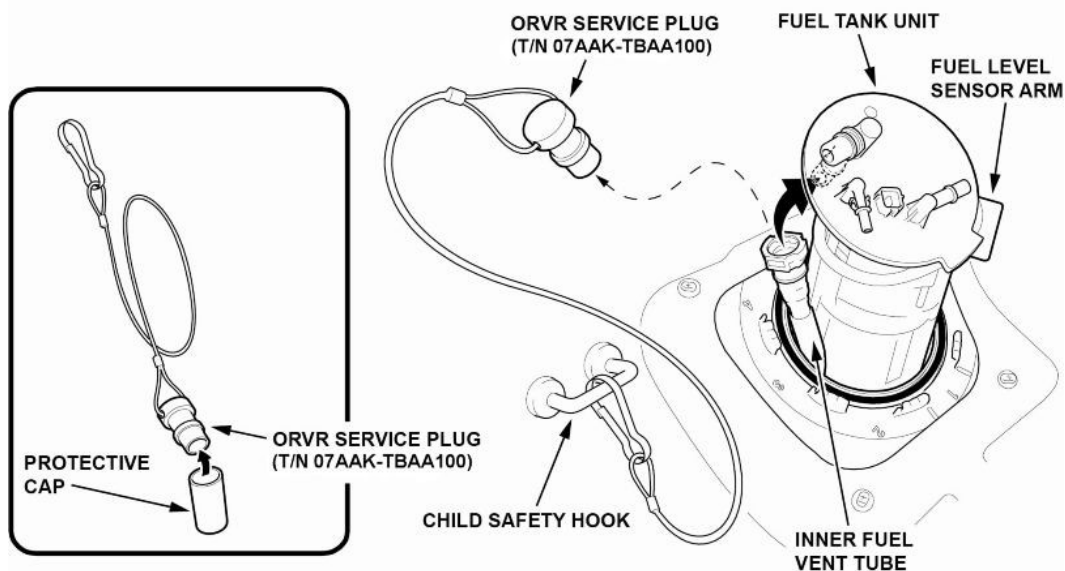

56. Remove the ORVR service plug from the child safety seat hook, and install the provided protective cap.

57. Line up the tab of the fuel tank unit as shown, and partially install the new fuel tank unit cam lock ring with a new O-ring.

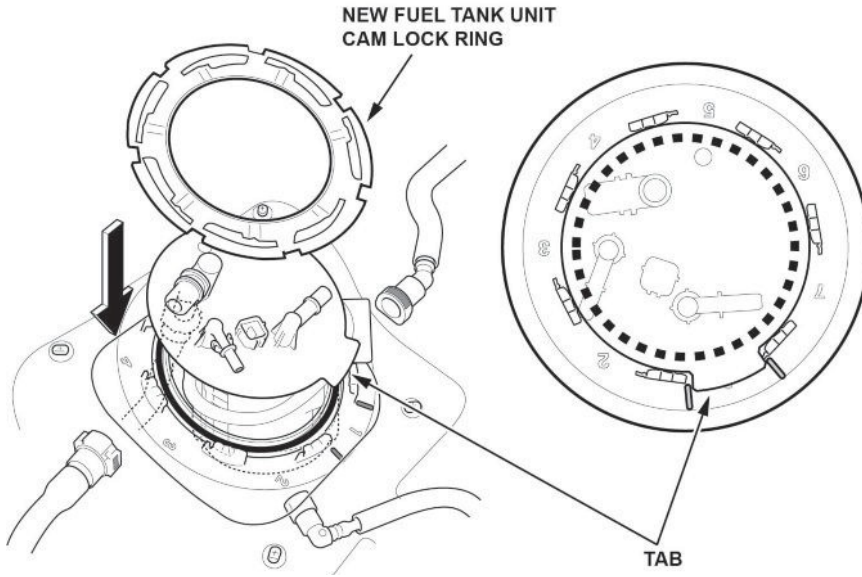

58. Connect the fuel vent tube and fuel tank vapor recirculation tube by slightly turning the fuel tank unit counterclockwise.  
NOTE: Do not bend the fuel vent tube and fuel tank vapor recirculation tube excessively.

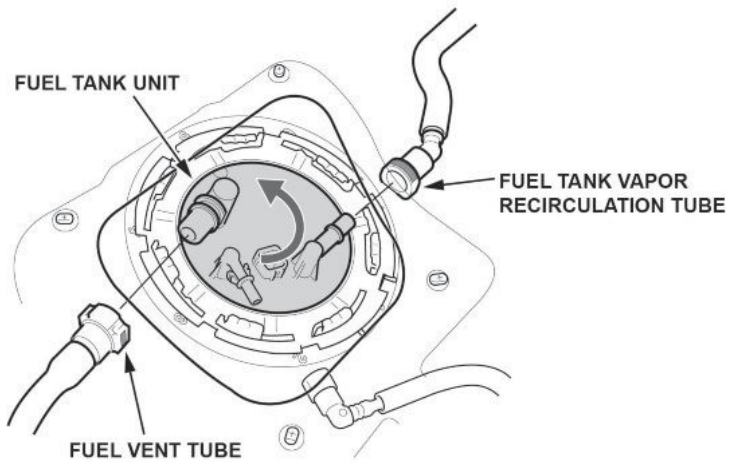

59. Turn the fuel tank unit cam lock ring by hand, and slide the fuel tank unit cam lock tabs to the positioning edge as shown.

**NOTICE**

Make sure the fuel cam lock ring is not floating. If the cam lock ring is not properly installed, the fuel tank can be damaged and will require replacement.

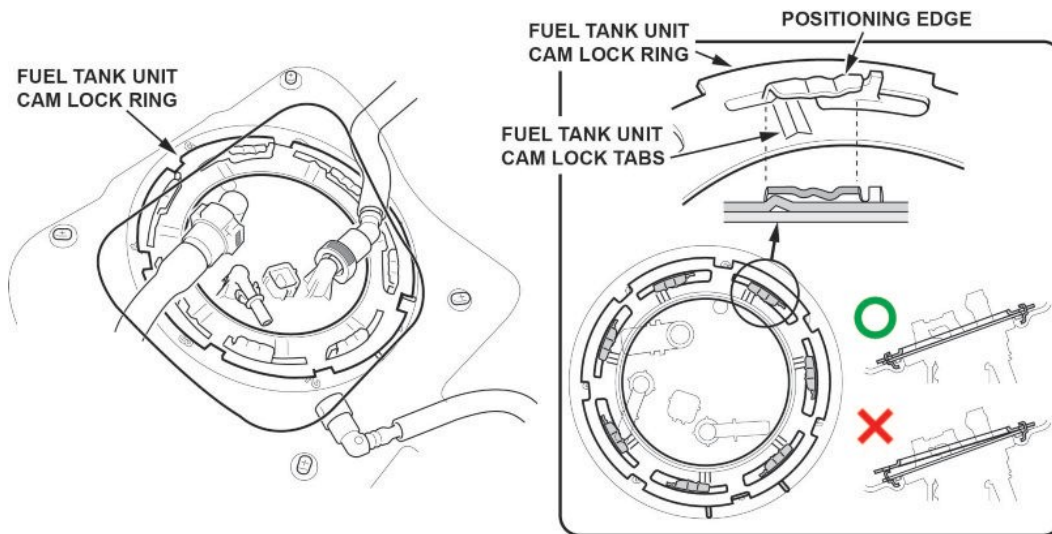

60. Tighten the fuel tank unit cam lock ring by turning clockwise using the fuel sender wrench.

**NOTE:**

- Keep the fuel sender wrench from floating.
- Securely set the positioning edge of the fuel tank to the tabs on the cam lock ring as shown.

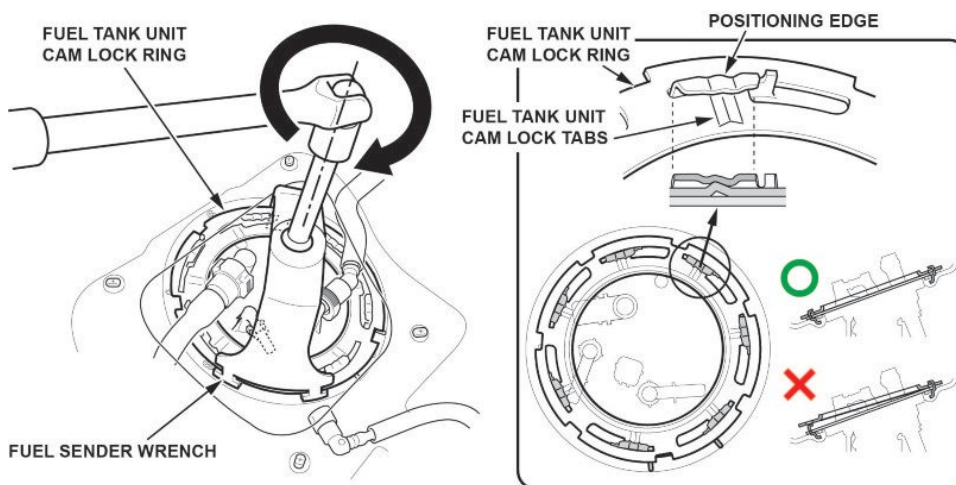

61. Remove the quick-connect fitting retainer from the fuel tank unit, then install a new retainer onto the quick-connect fitting.

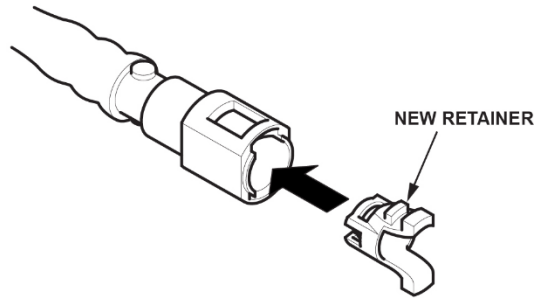

62. Connect the fuel line quick-connect fitting and connector.

NOTE: Install the connector cover if it was removed.

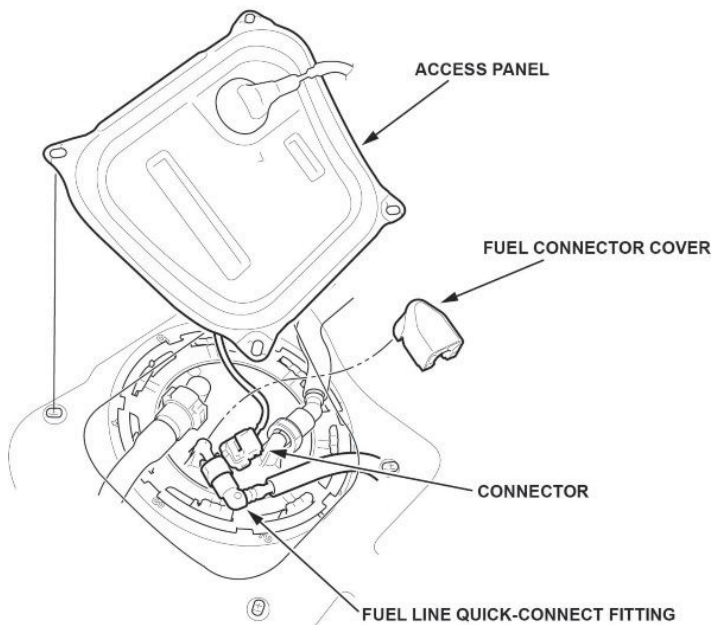

63. Connect the 12-volt battery terminals and torque to **2.9–5.9 N·m (2.1–4.4 lb-ft)**.
64. Turn the ignition to ON, but do not turn the engine on. After the fuel pump runs for about **2 seconds**, the fuel line will be pressurized. Repeat this two or three times, then make sure there is no fuel leakage.
65. Install the fuel tank unit access panel.
66. Install the remaining parts in the reverse order of removal.
67. Clear all DTCs using an i-HDS.
68. Do the VSA sensor neutral position memorization procedure.
69. *California residents only:* Fill out a Vehicle Emissions Recall – Proof of Correction certificate, and use **MGJ** as the recall number. Have the service advisor give the certificate to your customer, and advise him or her to keep it as proof that the recall was completed. Your customer will need to submit this certificate to the DMV only if the DMV requests it. If you need more certificates, use reorder number **Y0657**.

## Vehicle Emission Recall - Proof of Correction

License Number	Make	Year Model	Body Type	Vehicle Identification Number
				<input type="text"/>
Manufacturer _____			Recall Number <u>MGJ</u>	
The above described vehicle has been repaired, modified and/or equipped with _____ devices to meet applicable California Emission Control Laws.				
Dealer's Name _____		Address, City, State and Zip _____		
Date _____	Dealership's Authorized Signature _____			
X				
Return this certificate to DMV only when required - otherwise retain for your records.				

Y0657

ACL 24832 (0212)