

March 26, 2024

Version 2

## Safety Recall: 2019–20 and 2022 Insight Fuel Pump Motor

Supersedes 24-024, dated January 17, 2024, to revise the information highlighted in yellow.

### AFFECTED VEHICLES

Year	Model	Trim Level	VIN Range
2019–20, 2022	Insight	ALL	Check the iN VIN status for eligibility.

### REVISION SUMMARY

- The AFFECTED VEHICLES were updated.
- The BACKGROUND was updated.

### BACKGROUND

A certain number of 2019–20 and 2022 Insight units may have been built with a fuel pump motor or may have been repaired with a service part fuel pump assembly with defective impellers.

The fuel pump may seize and stop working. A defective impeller may cause the fuel pump to become inoperative, which could prevent an engine from functioning as intended. This limitation may cause a loss of motive power or a stall while being driven, increasing the risk of a crash or injury, creating a safety hazard.

If this bulletin appears during an iN VIN status inquiry, the vehicle is subject to a **safety recall**. Any affected vehicles in your dealer inventory are on **STOP SALE** until further notice. Refrain from calling Tech Line for updates.

### CUSTOMER NOTIFICATION

Owners of the affected vehicles will be sent a notification of this campaign. They will be informed that due to a limited supply of parts (at this time) Honda is **prioritizing** the repair of customer vehicles experiencing symptoms related to this recall.

When **adequate replacement parts** become available, Honda will send a follow-up letter to customers instructing them to schedule an appointment for all vehicles affected by this recall. If a customer experiences the known symptoms associated with this **safety recall** (see CORRECTIVE ACTION), they are instructed to contact their local Honda dealer for the repair.

For any questions or concerns customers may have, you may have them contact American Honda Customer Support & Campaign Center at **1-888-234-2138**.

The following suggested text should be included on any repair order for an already sold affected vehicle that comes in for service. This information should be printed out completely any time service is conducted on an affected vehicle, and the recall repair has not yet been completed. Depending on parts availability, the normal procedures under SOM 7.2.1 will apply for this recall.

**CUSTOMER INFORMATION:** The information in this bulletin is intended for use only by skilled technicians who have the proper tools, equipment, and training to correctly and safely maintain your vehicle. These procedures should not be attempted by “do-it-yourselfers,” and you should not assume this bulletin applies to your vehicle, or that your vehicle has the condition described. To determine whether this information applies, contact an authorized Honda automobile dealer.

## Suggested Verbiage to be Included on the Repair Order

Customer was advised that:

The vehicle is subject to a recall affecting the fuel pump motor. The parts necessary to complete the recall repair are currently limited. Vehicles with eligible VINs and the following symptoms: difficulty starting, engine hesitation while driving, and/or an illuminated check engine light displayed with DTC P0087, are eligible for immediate repair. Once parts repair kits are available, if the vehicle has not been repaired, the registered owner of the vehicle will receive a notice to bring the vehicle in for a replacement of the components, regardless of symptom.

## IMPORTANT NOTICE

Vehicles that are **both** shown as an eligible VIN and experiencing any of the following symptoms will be **prioritized** for repair: difficulty starting, engine hesitation while driving, and/or an illuminated check engine light displayed with DTC P0087 (Fuel Rail Pressure Too Low) stored.

## CORRECTIVE ACTION

Do an iN VIN status inquiry to make sure the vehicle is shown as eligible. If the allocated parts are available, follow the REPAIR PROCEDURE to replace the fuel pump motor. A limited number of parts have been allocated and will continue to be allocated based on availability at this time.

In the event that parts **are not** available, the **STOP SALE** remains in effect for that vehicle. To see if a vehicle in inventory is affected by this **safety recall**, do a VIN status inquiry before selling it. Some vehicles affected by this campaign may be in your new or used vehicle inventory.

## PARTS INFORMATION

NOTE:

- Due to a limited supply, parts will be automatically allocated to your dealership **based on availability**.
- Prioritize repairing customer vehicles that meet both the VIN status eligibility **and** exhibit a known symptom such as: difficulty starting, engine hesitation while driving, and/or an illuminated check engine light with DTC P0087 (Fuel Rail Pressure Too Low).

Part Name	Part Number	Quantity
Fuel Pump Motor Kit	06170-TXM-305	1

**For dealers experiencing a strong fuel smell from storing a fuel pump motor replaced under this service bulletin,** the fuel pump motor may be disposed of immediately in accordance with local regulations. This only applies to the fuel pump motor replaced under this service bulletin. The published retention policy remains in effect for all other parts.

If you have any questions about this exception or other parts retention issues, contact the WPI Administrative Office at **937-642-2737**.

## TOOL INFORMATION

Tool Name	Part Number	Quantity
Fuel Sender Wrench	070AA-TLA0100	1

## WARRANTY CLAIM INFORMATION

Operation Number	Description	Flat Rate Time	Defect Code	Symptom Code	Template ID	Failed Part Number
3101EH	Replace the fuel pump motor.	1.1 hr	6FE00	EGW00	A24024A	17045-TXM-A00

Skill Level: Repair Technician

### ⚠ WARNING

Fuel pump motor removal exposes fuel, which can ignite, causing a fire or explosion. This can cause serious injury or death.

Always work in a well-ventilated area and keep sparks or open flames away.

1. Relieve the fuel pressure.
  - Remove the fuel fill cap to relieve the pressure in the fuel tank.
2. Connect the i-HDS to the DLC (A) located under the driver's side of the dashboard.

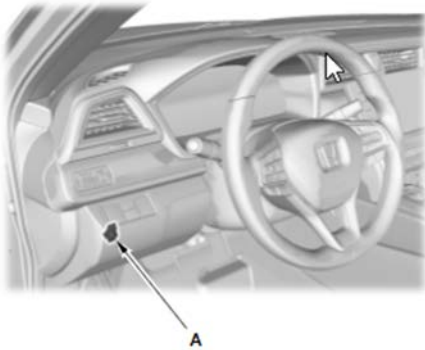

3. Select **PGM-FI** system on the i-HDS.
4. Select **FUEL PUMP OFF** from the Function Test menu.
5. When prompted, enter the maintenance mode.  
**NOTE:** Do the following procedure within **60 seconds** to start the engine in the maintenance mode.
6. While in the P position, press the accelerator pedal to the floor twice, then release it.
7. Press the brake pedal and shift the transmission to the N position, then press the accelerator pedal to the floor twice, then release it.
8. Press the brake pedal, and shift the transmission to the P position, then press the accelerator pedal to the floor twice, then release it.
9. Press the engine start/stop button while pressing down on the brake pedal. The vehicle is now in the maintenance mode and the engine will start.

**NOTE:** **Maintenance Mode** will be displayed on the MID.

10. Follow the i-HDS screen prompts to stall the engine.
11. When the engine stalls, immediately turn the ignition to OFF.

**NOTE:**

- The engine may start again momentarily and stall if you do not turn the ignition to OFF.
- Do not turn the ignition to ON after turning it OFF.

12. Remove the center console side panel, then disconnect the 12-volt battery negative terminal.

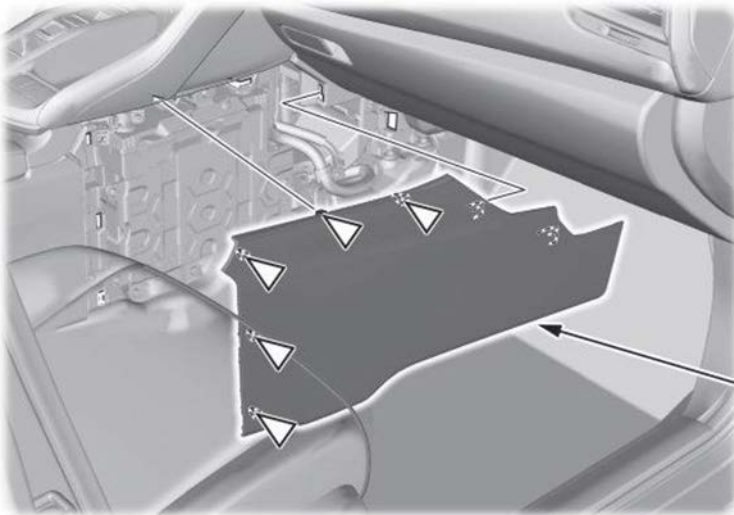

CENTER CONSOLE SIDE PANEL

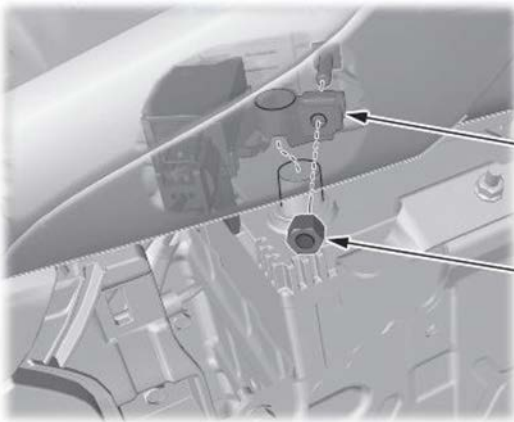

NEGATIVE TERMINAL

2.9-5.9 N·m  
(2.1-4.4 lb-ft)

13. Remove the rear seat-back:

**Rear Seat-Back (Fold-Down Seat)**

- Pull out the center seat belt through the slit in the center seat belt guide.

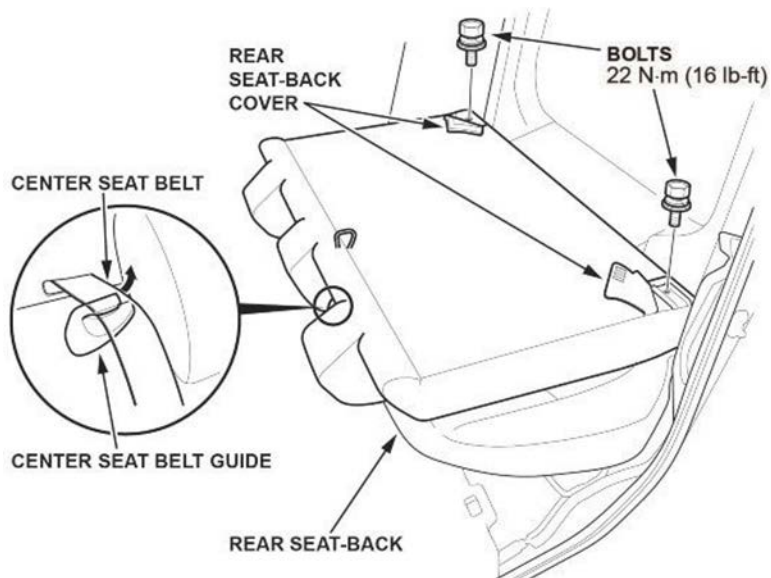

- Fold down the rear seat-back.
- Turn over the rear seat-back cover, then remove the bolts.
- Remove the rear seat-back.

**Rear Seat-Back (Split Fold-Down Seat)**

- Fold down the rear right seat-back.
- Turn over the rear right seat-back cover, then remove the bolts.

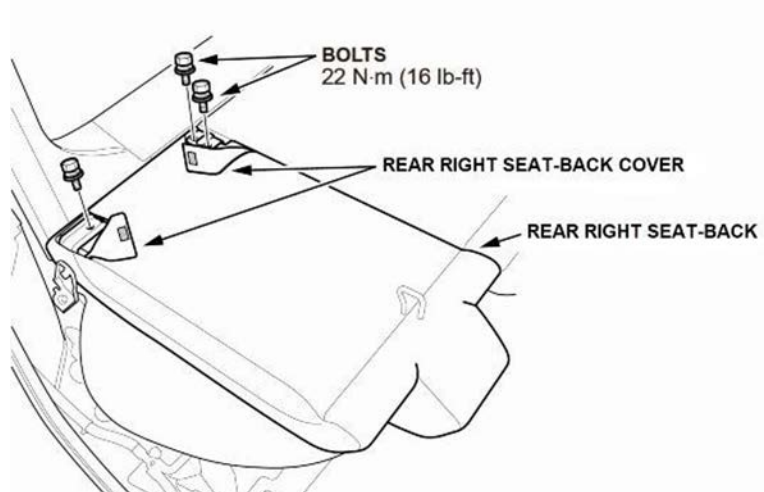

- Remove the rear right seat-back

- Pull out the center seat belt through the slit in the center seat belt guide.

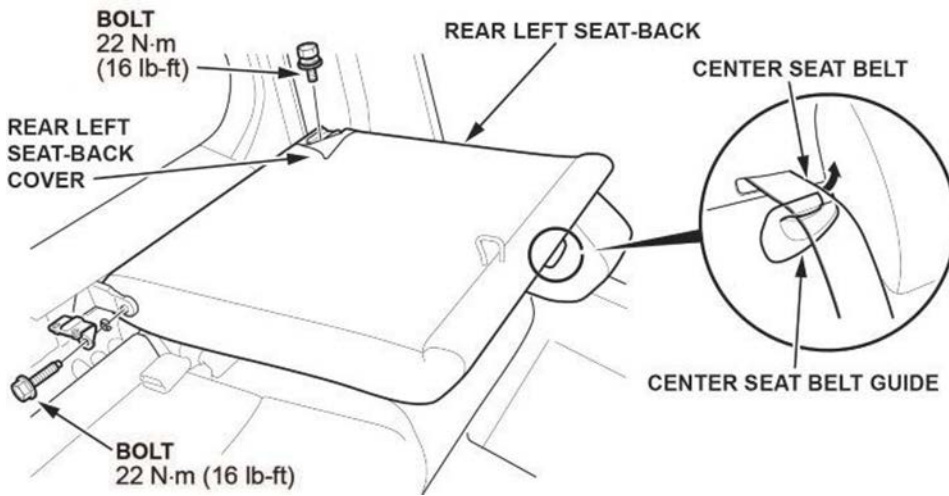

- Fold down the rear left seat-back.
- Turn over the rear left seat-back cover, then remove the bolts.
- Remove the rear left seat-back.

14. Remove the rear seat cushion:

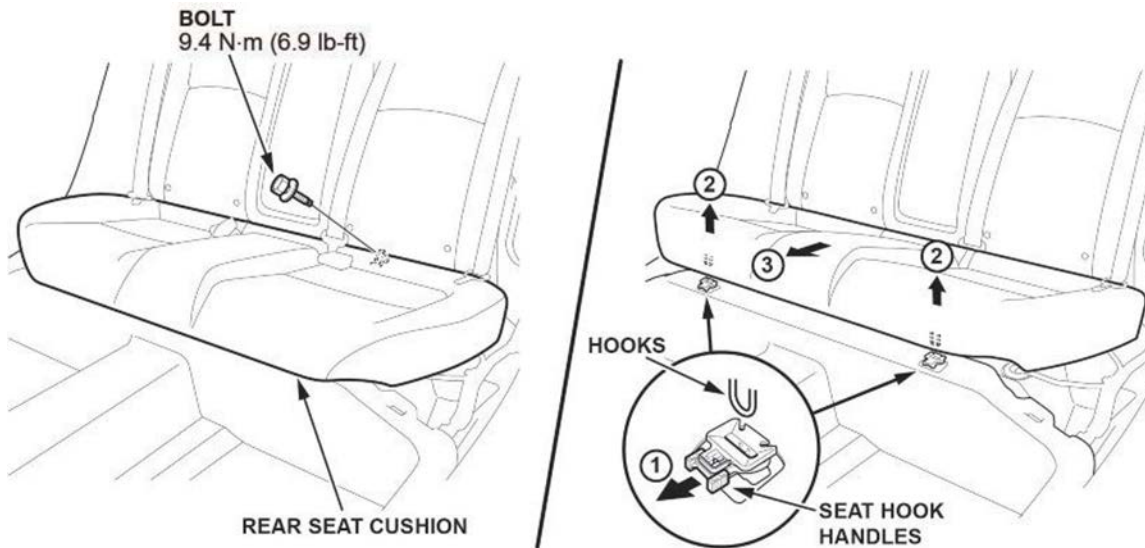

- While pushing down on the seat cushion, pull the seat hook handles to release the hooks.
- Remove the rear seat cushion

15. Remove the fuel tank unit access panel and disconnect the connector.

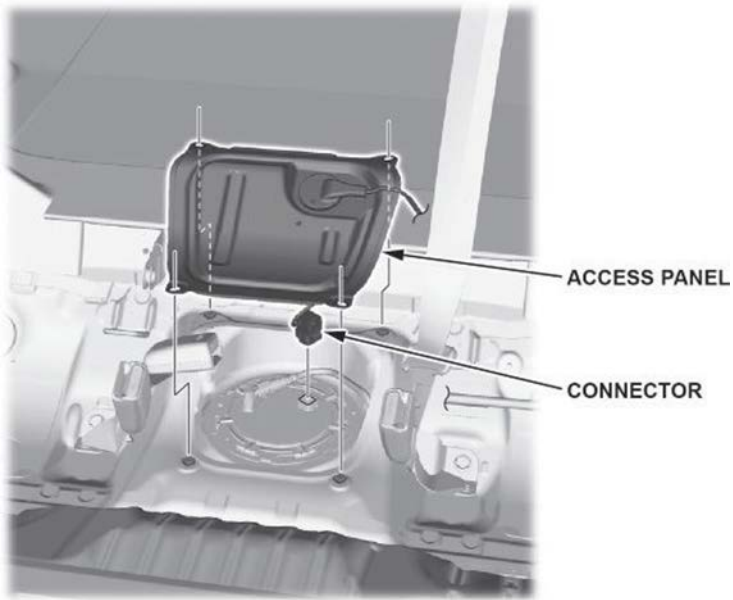

16. Place a rag or shop towel over the quick-connect fitting and disconnect it.



17. Unlock the fuel tank unit cam lock ring using the fuel sender wrench (070AA-TLA0100):

- Set the fuel sender wrench as shown.

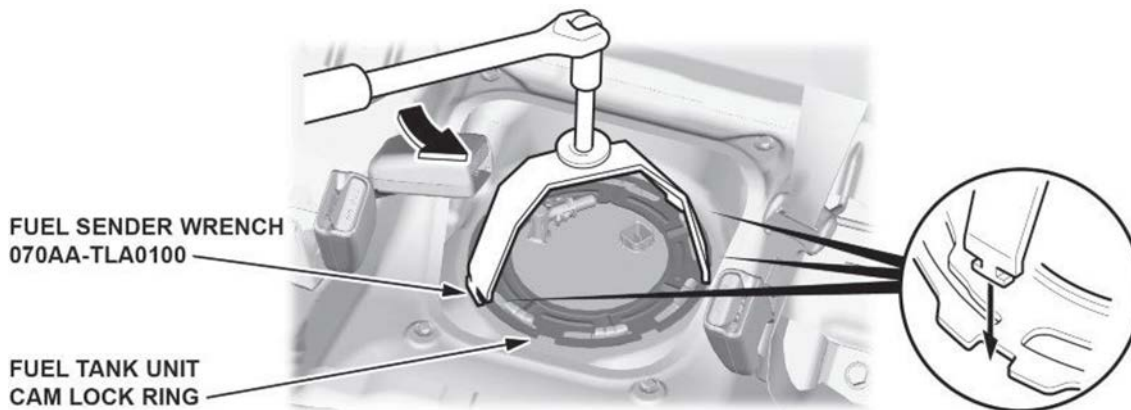

- Turn the fuel tank unit cam lock ring counterclockwise.

NOTE:

- After unlocking the fuel tank unit cam lock ring, clean the top of the fuel pump flange and adjacent areas to make sure it's free of dirt, dust, and debris.
- Keep the fuel sender wrench from floating.

18. Remove the fuel tank unit.

NOTE: Make sure not to bend or twist the fuel level sensor arm excessively.



19. Disassemble the fuel tank unit.

- Prepare the fuel pump and parts to be replaced.

NOTE: Take a photo of the fuel tube and wire harness and note their routing for assembly. There are various types of routing.

- Spread the wire harness clamps and remove the wire harness.

NOTE:

- Make sure not to damage the wire harness.
- Do not spread the clamps too wide. Spreading the clamps too wide may damage them.

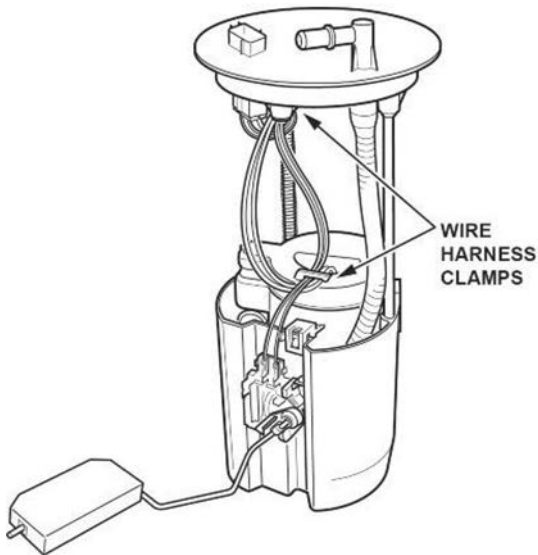



- Remove the fuel level sensor.
- Disconnect the harnesses.

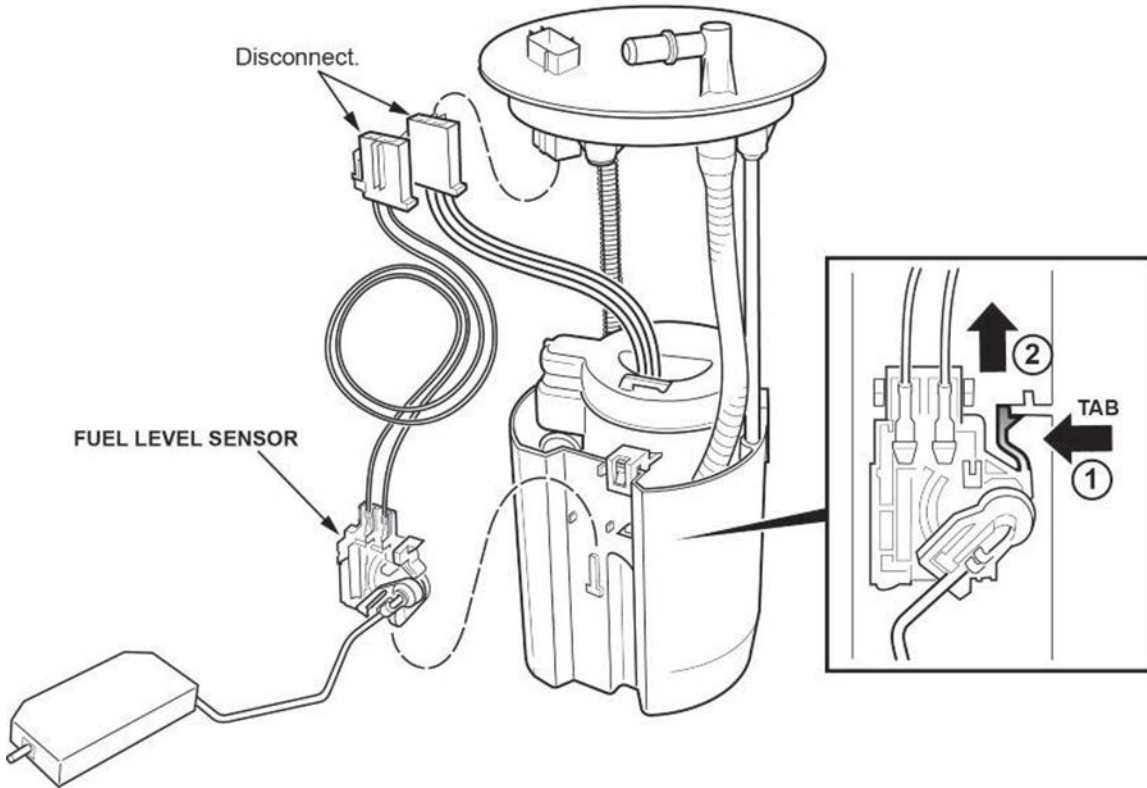

- Press the tab to release the lock (1). Then, push up on the fuel gauge sending unit (2).
- Remove the fuel level sensor from the fuel tank unit.
- Remove the E-ring and throw it away. **Do not use it again.**

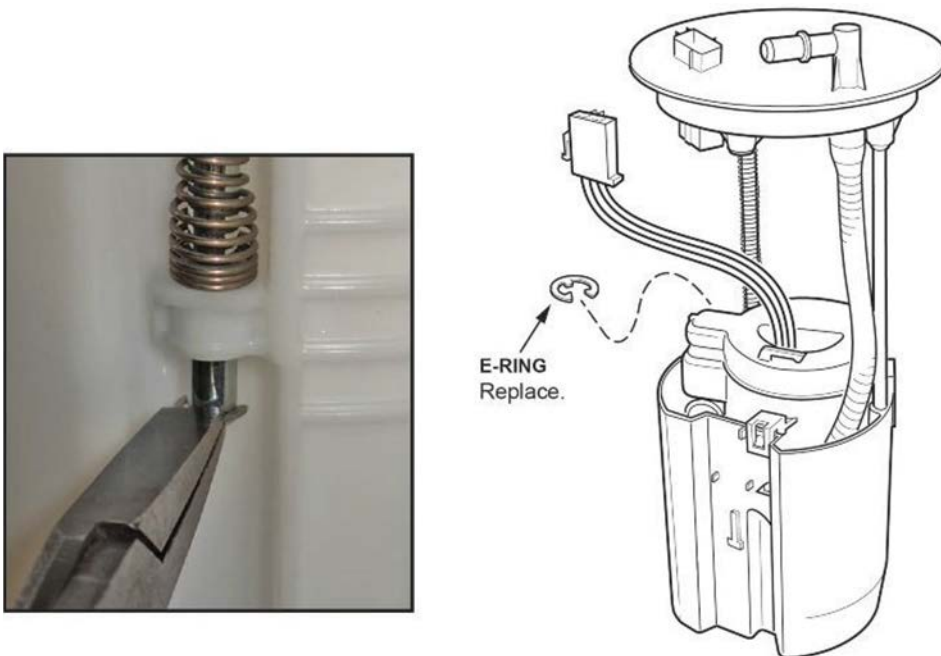

- Remove the fuel filter assembly from the reservoir by releasing the three clips.

**NOTE:**

- Do not spread the clips too wide. Spreading them too wide may damage them.
- If the O-ring remains on the fuel filter, use a flat-tip screwdriver wrapped in protective tape to remove it. Take care not to damage the O-ring seat section.
- The spring may slide off the sliding shaft. Retain this spring. It will be used during assembly.

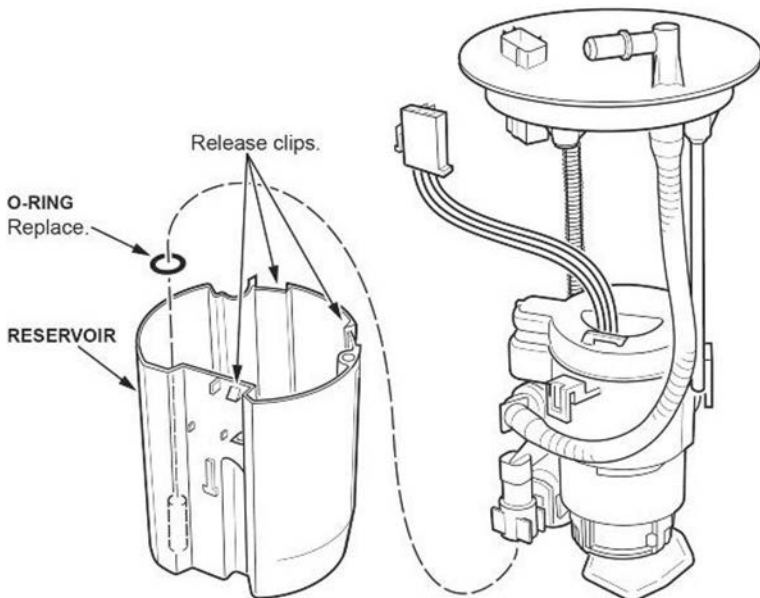

- Remove the fuel pump assembly from the fuel filter.
- Release the three clips at the base of the fuel pump assembly.
- Pull the fuel pump assembly out of the fuel filter.

**NOTE:** If the O-ring remains on the fuel filter, use a flat-tip screwdriver wrapped in protective tape to remove it. Make sure not to damage the O-ring seat section.

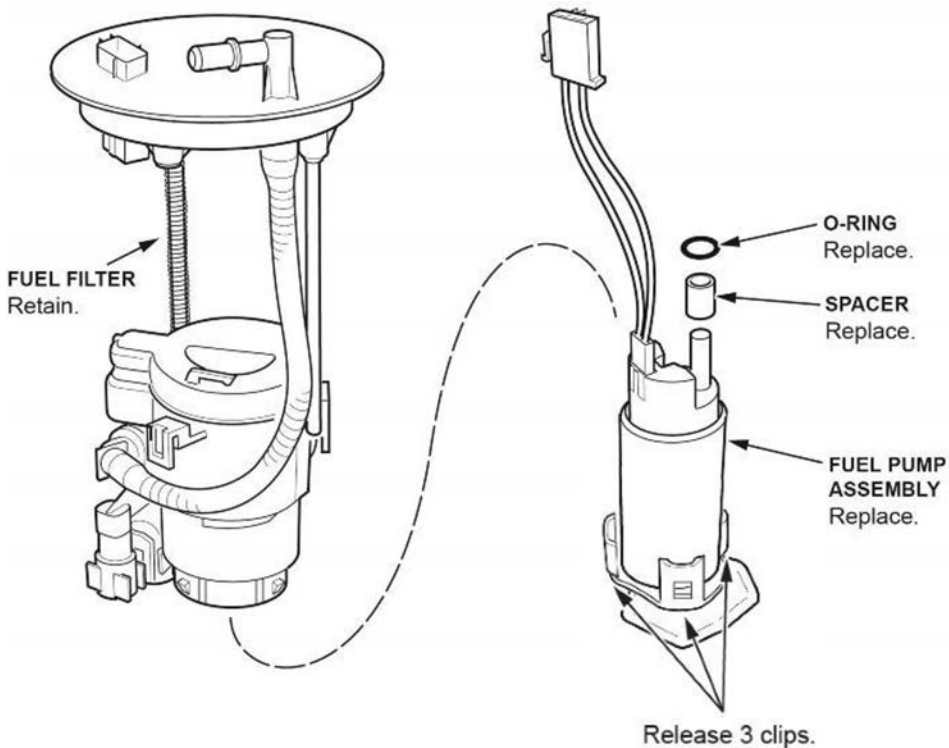

20. Install the new spacer on the new fuel pump motor.

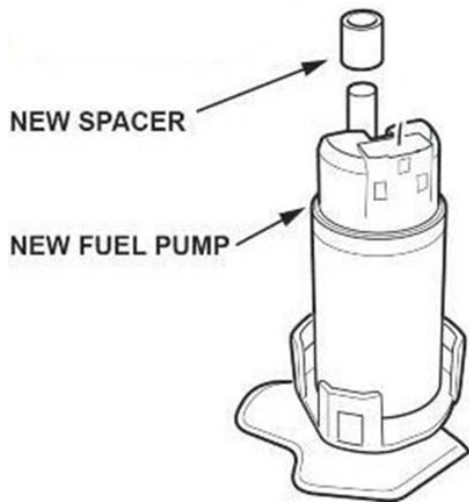

21. Install the new O-ring, then lubricate ONLY the outside edge of it, using clean engine oil.

NOTE: Do not pinch the O-ring during installation.

**NEW O-RING**

Lubricate after installing.

Do not lubricate the inside of the o-ring.

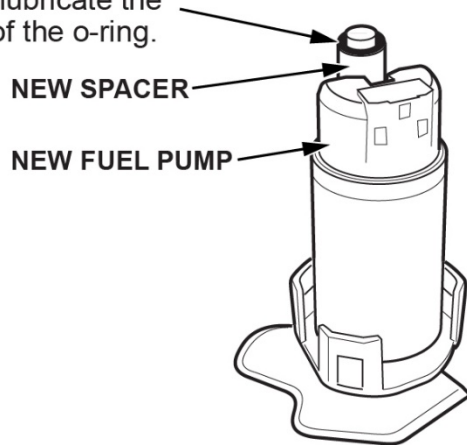

22. Install the new harness and make sure the connection is secure and the connectors are firmly locked into place.

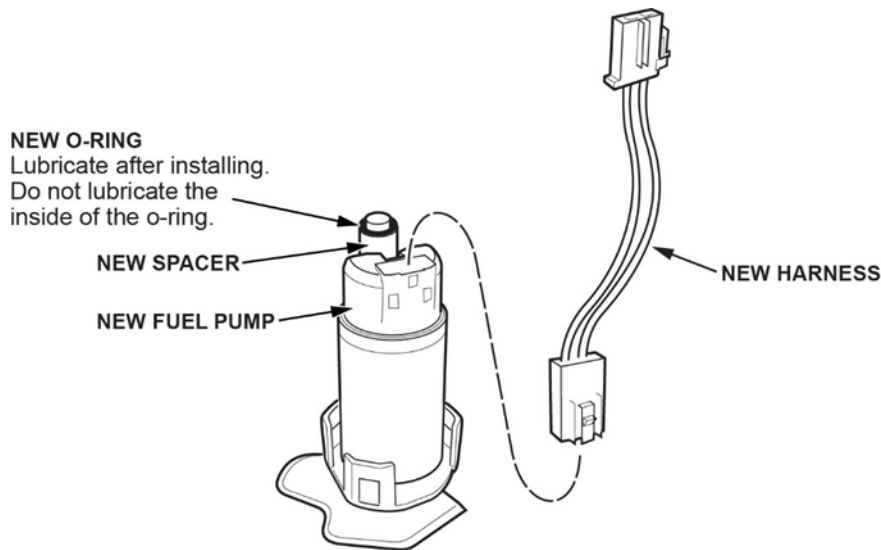

23. With the palm of your hand, press the fuel pump into the suction fuel filter.

[▶ PLAY VIDEO](#)

Click here to view the video:

**NOTICE**

When pressing the fuel pump into the suction filter, make sure you do so with a single firm push. Failure to do so may damage the O-ring. If it is seated properly, you will hear a click.

If you do not hear the click, remove all parts and inspect the O-ring for damage. If the O-ring is damaged, it must be replaced. Reassemble using the above process.

**NOTE:**

- When inserting the pump, be careful not to break the suction filter.
- If the O-ring is damaged, replace it with a new one.
- After installing the fuel pump to the suction filter, make sure the clips are firmly attached to the new fuel pump.

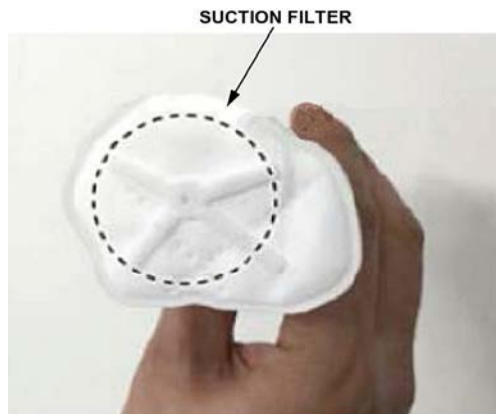

**GOOD**



**NO GOOD**



24. Install the fuel filter assembly to the reservoir.

- Insert the spring to the sliding shaft and make sure it is aligned when installing the fuel filter.

NOTE:

- Make sure the fuel tube is routed exactly as shown in the photo taken before disassembly.
- Make sure the three clips are fully engaged.

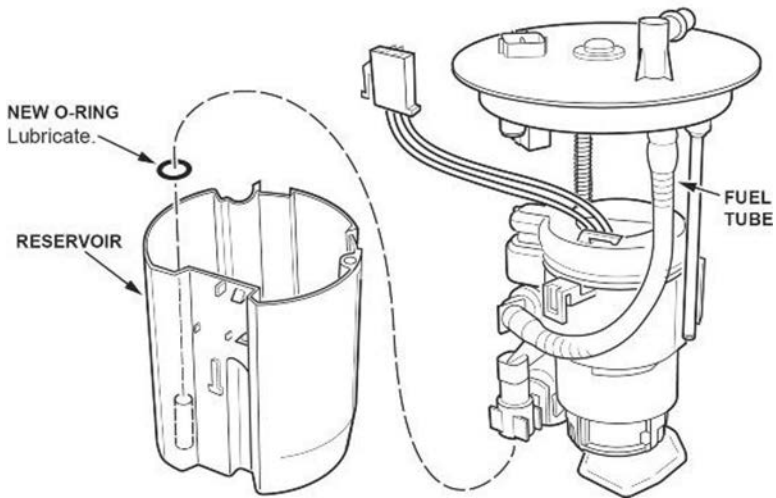

25. Install the new E-ring.

NOTE: After installation, make sure the E-ring can be rotated with your finger. If it cannot be rotated, the E-ring may not be fully seated or may be incorrectly installed.

26. Install the fuel level sensor to the reservoir. Make sure the lock is engaged.

NOTE: When installing the fuel level sensor, make sure the connection is secure and the connector is firmly locked into place. Be careful not to bend or twist it excessively.

27. Install the wiring harness to the clamps.

**NOTE:**

- Clip in the smaller harness wires followed by the larger wires.
- Make sure not to damage the wire harness.
- Make sure the wire harness is routed exactly as shown in the photo taken before disassembly.
- Do not spread the clamps too wide. Spreading them too wide may damage them.

**HARNES ROUTING:**

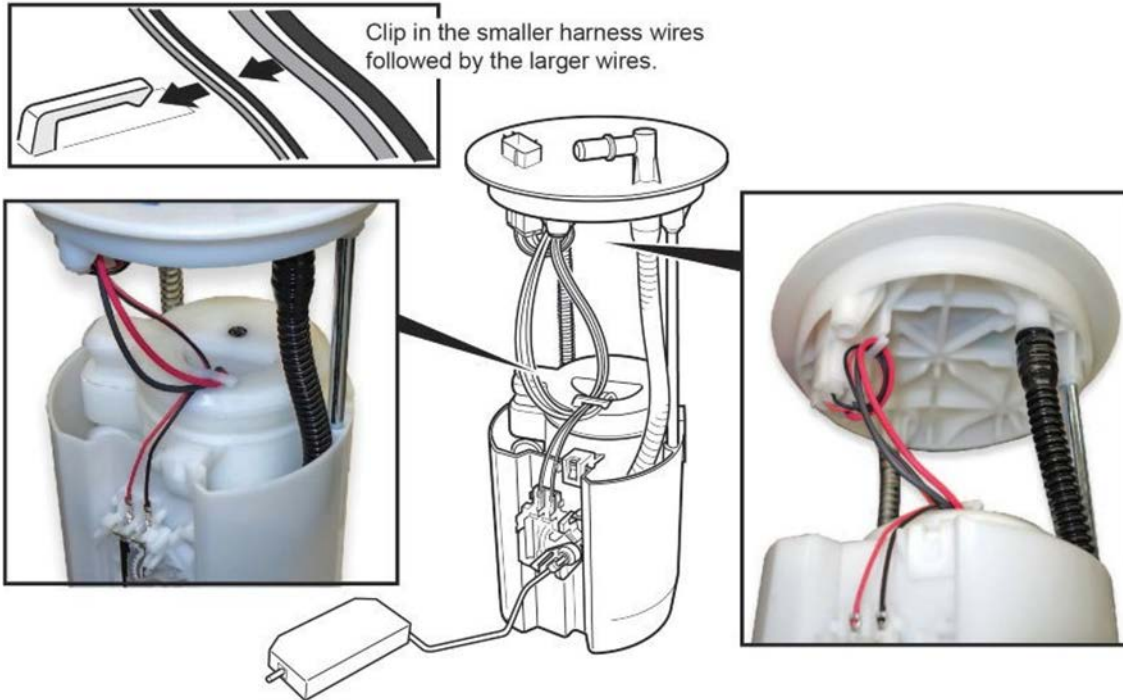

28. While compressing the fuel tank unit, make sure the movement is smooth and the fuel tube and wiring harness do not pinch or bind.

NOTE:

- Make sure the wire harness is not stretched.
- Make sure the fuel tube is not pinched.

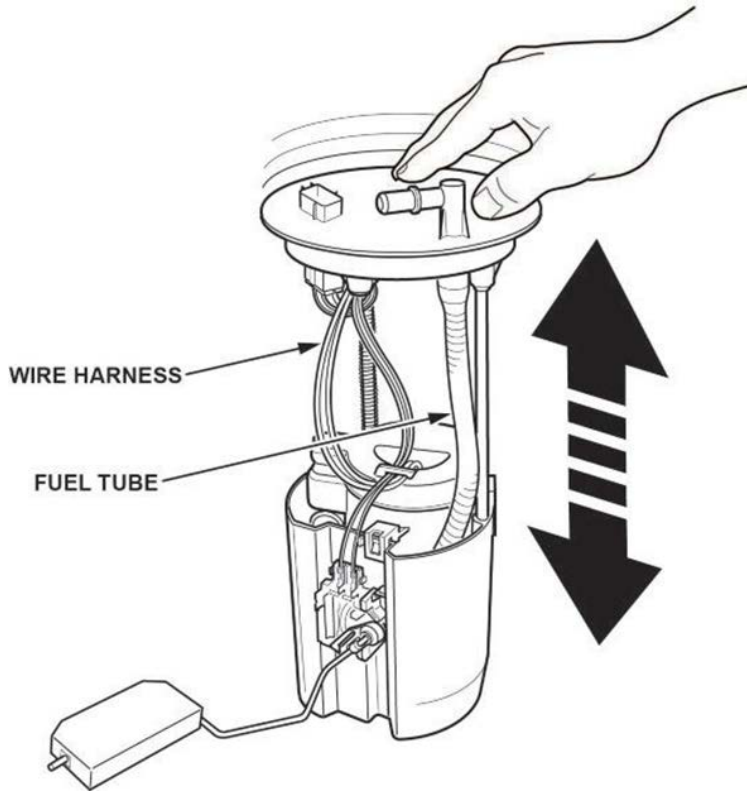

29. Install the fuel tank unit.

- Partially insert the fuel tank unit into the fuel tank with a new O-ring.

NOTE:

- Before installing the new O-ring, clean the fuel tank around the fuel pump opening where the O-ring will seat. The tank opening must be free of dirt, dust, and debris.
- Be careful not to damage the new O-ring.
- Do not coat the O-ring with any oil.



- Line up the tab of the fuel tank unit as shown, and temporarily insert the new fuel tank unit cam lock ring.

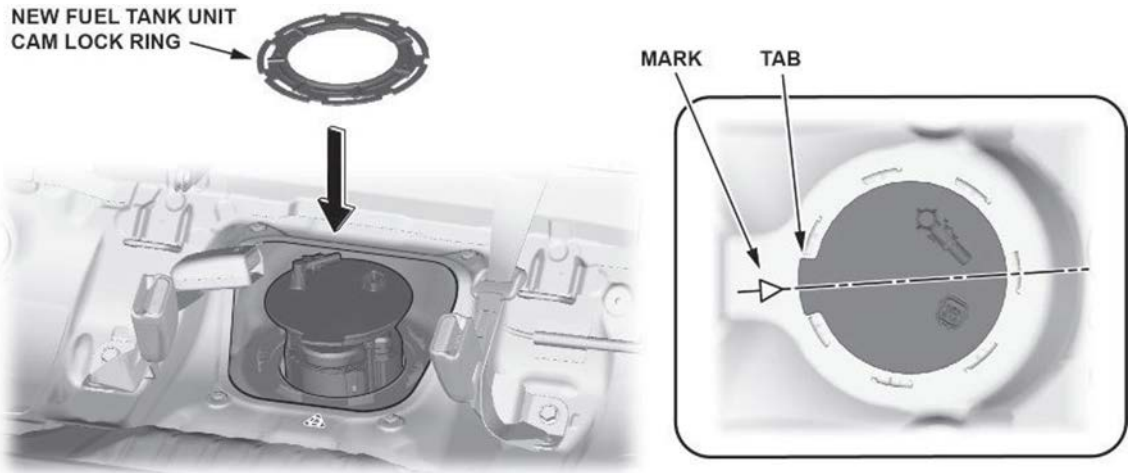

30. Lock the fuel tank unit cam lock ring.

**NOTICE**

If the cam lock ring is not properly installed, the fuel tank can be damaged and will require replacement.

- Rotate the fuel tank unit cam lock ring and slide the fuel tank unit cam lock tabs to the positioning edge as shown, by hand.

NOTE: Make sure the fuel tank unit cam lock ring is not floating.

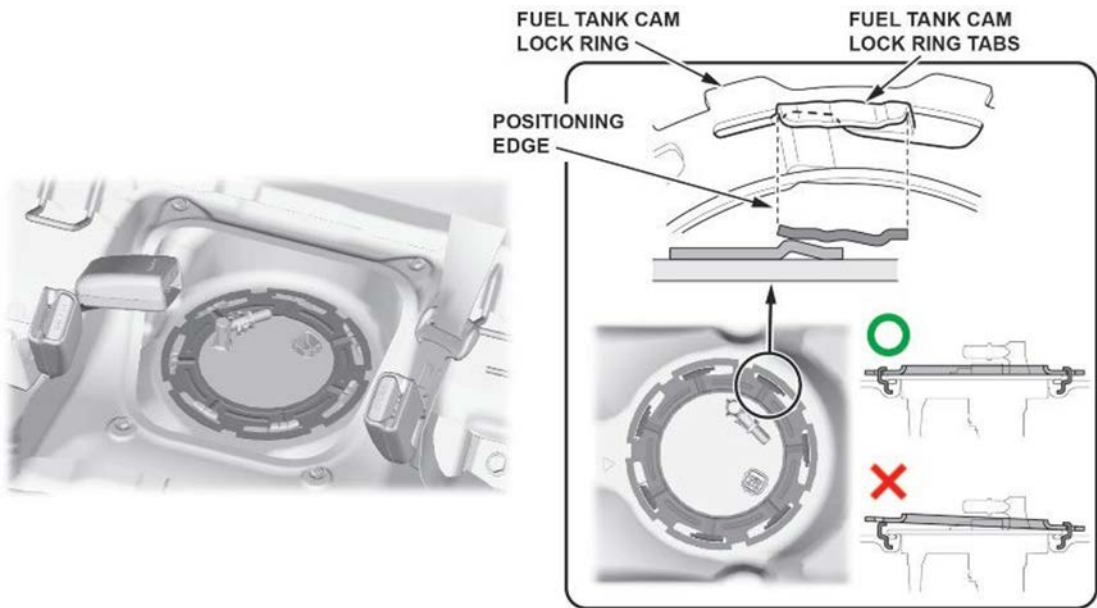



- Turn the fuel tank unit cam lock ring clockwise using the fuel sender wrench.

NOTE:

- Keep the fuel sender wrench from floating.
- Securely set the positioning edge of the fuel tank at the fuel tank unit cam lock ring tabs on the fuel tank unit cam lock ring as shown.

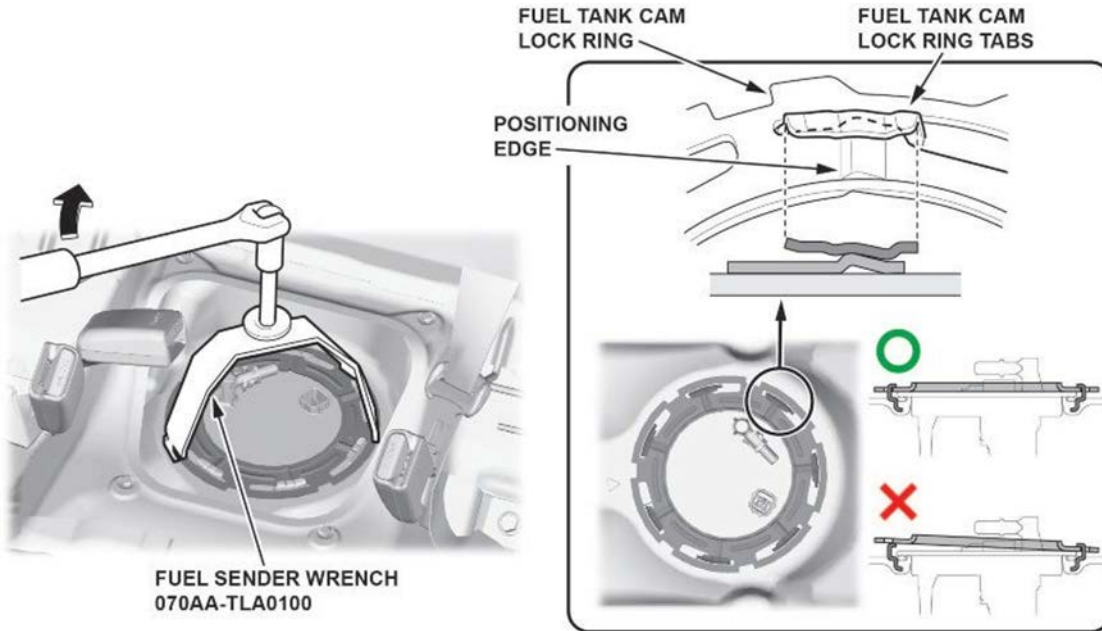

31. Install the new retainer to the quick-connect fitting.

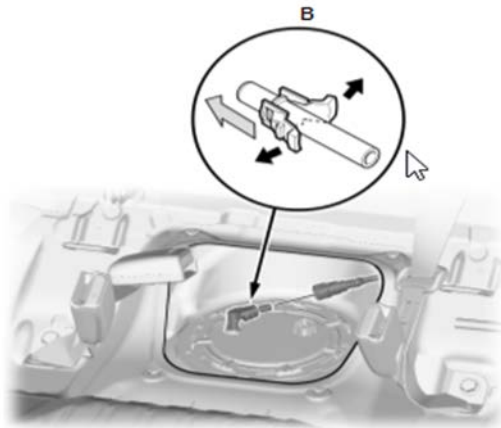

32. Connect the fuel line quick-connect fitting.

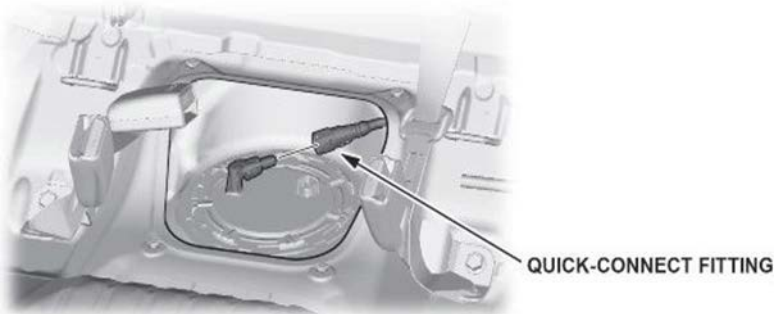

33. Connect the Negative 12V Battery Cable **2.9–5.9 N·m (2.1–4.4 lb-ft)**.

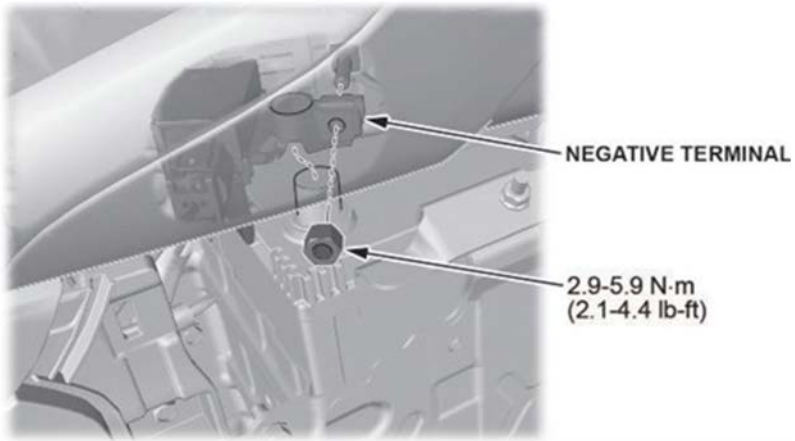

34. Install the center console side panel.

**Fastener Locations**

▷ : 5

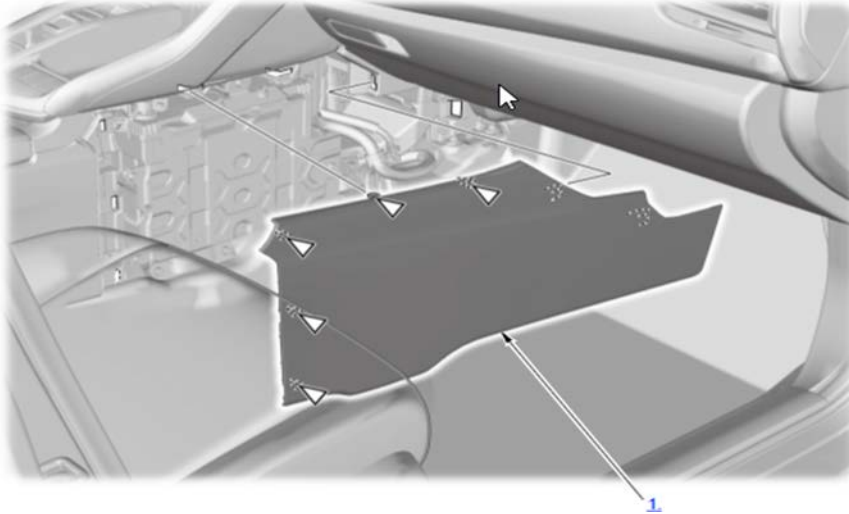

35. Connect the fuel tank unit connector.

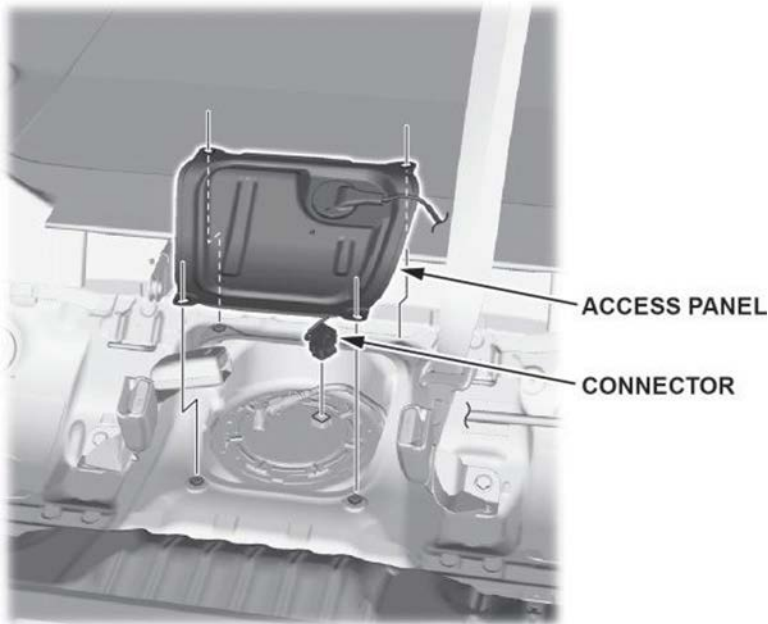

36. Check for fuel leaks.

- Turn the ignition to ON, but do not turn to the READY TO DRIVE mode. After the fuel pump runs for about 2 seconds, the fuel line will be pressurized. Repeat two or three times, then make sure there is no fuel leakage.

37. Install the fuel tank unit access panel.

38. Install the remaining parts in the reverse order of removal.

39. Clear all DTCs using an i-HDS.

40. Do the VSA Sensor Neutral Position Memorization procedure.

41. *California residents only:* Fill out a Vehicle Emissions Recall – Proof of Correction certificate and use **EGW** as the recall number. Have the service advisor give the certificate to your customer and advise him or her to keep it as proof that the recall was completed. Your customer will need to submit this certificate to the DMV only if the DMV requests it. If you need more certificates, use reorder number **Y0657**.

Vehicle Emission Recall - Proof of Correction				
License Number	Make	Year Model	Body Type	Vehicle Identification Number
Manufacturer _____			Recall Number <b>EGW</b>	
The above described vehicle has been repaired, modified and/or equipped with new emission control devices to meet applicable California Emission Control Laws.				
Dealer's Name _____		Address, City, State and Zip _____		
Date _____	Dealership's Authorized Signature _____			
X				
Return this certificate to DMV only when required - otherwise retain for your records.				

Y0657 ACL 24832 (0212)