

Safety Recall: 2018–20 ILX Fuel Pump Motor

AFFECTED VEHICLES

Year	Model	Trim Level	VIN Range
2018–20	ILX	ALL	Check the iN VIN status for eligibility.

BACKGROUND

On December 18, 2023, Acura notified NHTSA of its intention to initiate a **STOP SALE** and **safety recall** for a certain number of 2018–20 ILX units in order to replace the fuel pump motor manufactured with defective impellers.

Due to swelling of the fuel pump motor impeller, the fuel pump may seize and stop working. A defective impeller may cause the fuel pump to become inoperative, which could prevent an engine from functioning as intended. This limitation may cause a loss of motive power or a stall while being driven, increasing the risk of a crash or injury, creating a safety hazard.

If this bulletin appears during an iN VIN status inquiry, the vehicle is subject to a **safety recall**. Any affected vehicles in your dealer inventory are on **STOP SALE** until further notice. Refrain from calling Tech Line for updates.

CLIENT NOTIFICATION

Owners of the affected vehicles will be sent a notification of this campaign. They will be informed that due to a limited supply of parts (at this time) Acura is **prioritizing** the repair of client vehicles experiencing symptoms related to this recall.

When **adequate replacement parts** become available, Acura will send a follow-up letter to clients instructing them to schedule an appointment for all vehicles affected by this recall. If a client experiences the known symptoms associated with this **safety recall** (see CORRECTIVE ACTION), they are instructed to contact their local Acura dealer for the repair.

For any questions or concerns clients may have, you may have them contact American Honda's Customer Support & Campaign Center at **1-888-234-2138**.

The following suggested text should be included on any repair order for an already sold affected vehicle that comes in for service. This information should be printed out completely any time service is conducted on an affected vehicle, and the recall repair has not yet been completed. Depending on parts availability, the normal procedures under DOM 7.2.1 will apply for this recall.

Suggested Verbiage to be Included on the Repair Order

Client was advised that:

The vehicle is subject to a recall affecting the fuel pump motor. The parts necessary to complete the recall repair are currently limited. Vehicles with eligible VINs and the following symptoms: difficulty starting, engine hesitation while driving, and/or an illuminated check engine light displayed with DTC P0087, are eligible for immediate repair. Once parts repair kits are available, if the vehicle has not been repaired, the registered owner of the vehicle will receive a notice to bring the vehicle in for a replacement of the components, regardless of symptom.

CLIENT INFORMATION: The information in this bulletin is intended for use only by skilled technicians who have the proper tools, equipment, and training to correctly and safely maintain your vehicle. These procedures should not be attempted by "do-it-yourselfers," and you should not assume this bulletin applies to your vehicle, or that your vehicle has the condition described. To determine whether this information applies, contact an authorized Acura automobile dealer.

IMPORTANT NOTICE

Vehicles that are **both** shown as an eligible VIN and experiencing any of the following symptoms will be **prioritized** for repair: difficulty starting, engine hesitation while driving, and/or an illuminated check engine light displayed with DTC P0087 (Fuel Rail Pressure Too Low) stored.

CORRECTIVE ACTION

Do an iN VIN status inquiry to make sure the vehicle is shown as eligible. If the allocated parts are available, follow the REPAIR PROCEDURE to replace the fuel pump motor. A limited number of parts have been allocated and will continue to be allocated based on availability at this time.

In the event that parts **are not** available, the **STOP SALE** remains in effect for that vehicle. To see if a vehicle in inventory is affected by this **safety recall**, do a VIN status inquiry before selling it. Some vehicles affected by this campaign may be in your new or used vehicle inventory.

PARTS INFORMATION

NOTE:

- Due to a limited supply, parts will be automatically allocated to your dealership **based on availability**.
- Prioritize repairing client vehicles that meet both the VIN status eligibility **and** exhibit a known symptom such as: difficulty starting, engine hesitation while driving, and/or an illuminated check engine light with DTC P0087 (Fuel Rail Pressure Too Low).

Part Name	Part Number	Quantity
Fuel Pump Motor Kit	06170-TV9-305	1

For dealers experiencing a strong fuel smell from storing a fuel pump motor replaced under this service bulletin, the fuel pump motor may be disposed of immediately in accordance with local regulations. This only applies to the fuel pump motor replaced under this service bulletin. The published retention policy remains in effect for all other parts.

If you have any questions about this exception or other parts retention issues, contact the WPI Administrative Office at **937-642-2737**.

TOOL INFORMATION

Tool Name	Tool Number	Quantity
Fuel Pump Module Locknut Wrench	07AAA-SNA0100	1

WARRANTY CLAIM INFORMATION

Operation Number	Description	Flat Rate Time	Defect Code	Symptom Code	Template ID	Failed Part Number
3101EH	Replace the fuel pump motor.	1.2 hr	6FE00	UGO00	B24008A	17045-TV9-A00

Skill Level: Repair Technician

REPAIR PROCEDURE

⚠ WARNING

Fuel pump motor removal exposes fuel, which can ignite, causing a fire or explosion.

This can cause serious injury or death.

Always work in a well-ventilated area and keep sparks or open flames away.

1. Remove the fuel fill cap to relieve the pressure in the fuel tank.
2. Relieve the fuel pressure with the i-HDS:
 - Connect an i-HDS to the DLC under the driver's side of the dashboard.

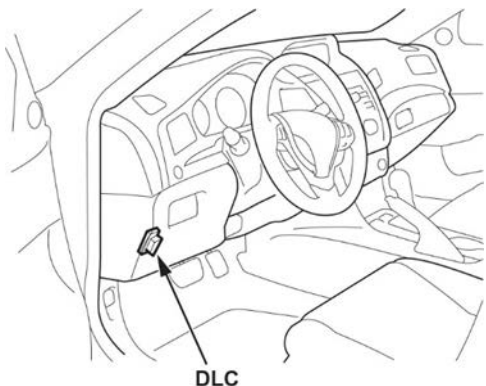

- Turn the vehicle to ON.
 - Select the PGM-FI system on the i-HDS.
 - Select **FUEL PUMP OFF** from the Function Test menu.
 - Start the engine and let it idle until it stalls.
 - Turn the ignition to OFF.
3. Relieve the fuel pressure without the i-HDS:
 - Remove the PGM-FI main relay 2 from the under-dash fuse/relay box.

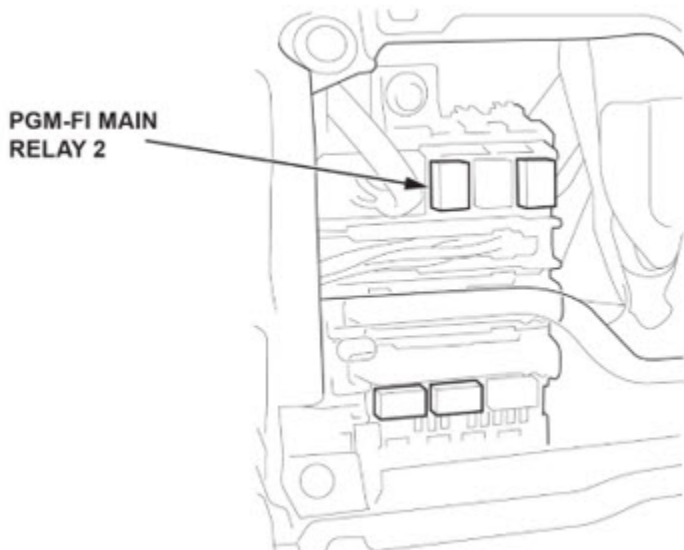

- Start the engine and let it idle until it stalls.
- Turn the ignition to OFF.
- Install the PGM-FI main relay 2.

NOTE:

- Do not allow the engine to idle above 1,000 rpm, or the PCM will continue to operate the fuel pump.
- A pending or confirmed DTC may be set during this procedure. After the repair is complete, check for DTCs and clear them as needed.

4. Disconnect both 12-volt battery terminals.

NOTE:

- To protect the terminal connector from damage, do not hold it when removing the negative terminal.
- Always disconnect the negative terminal first.
- Do not disconnect the 12-volt battery sensor from the cable.

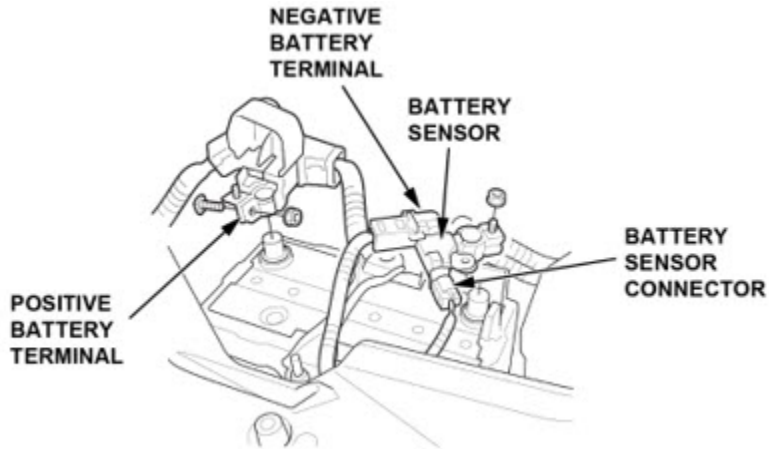

5. Remove the seat cushion bolt.

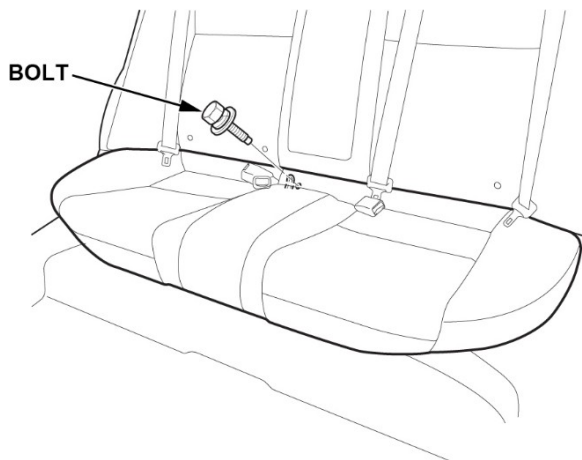

6. While pushing down on the rear seat cushion, pull the seat hook handles to release the hooks.

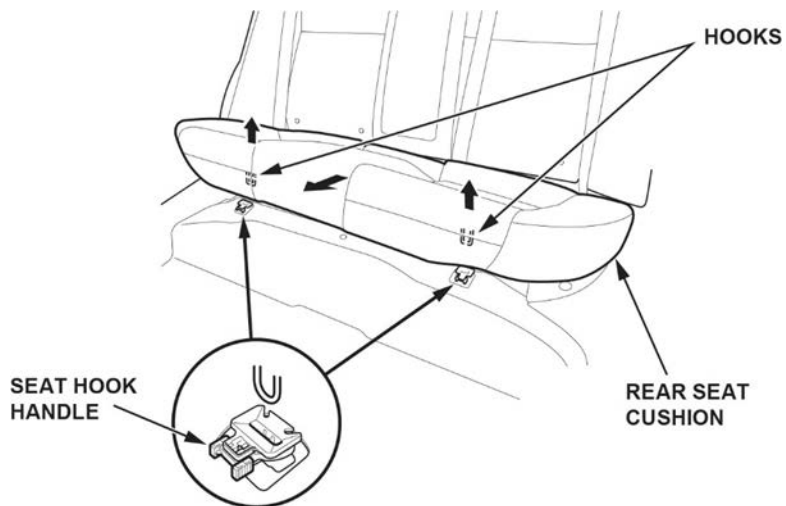

7. Remove the rear seat cushion.

8. Fold down the rear seat-back, turn over the bottom of rear-seat back cover and remove the bolts.

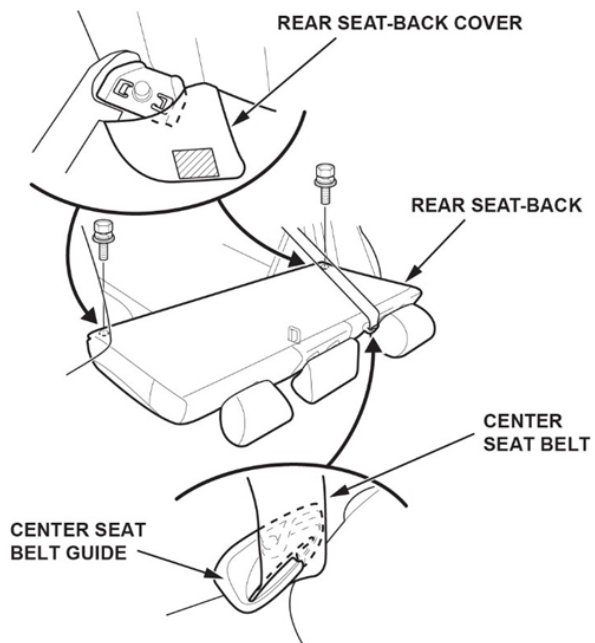

9. Pull out the center seat belt through the center seat belt guide and remove the rear seat-back.

10. Remove the clip from the front area of the trunk floor cover.

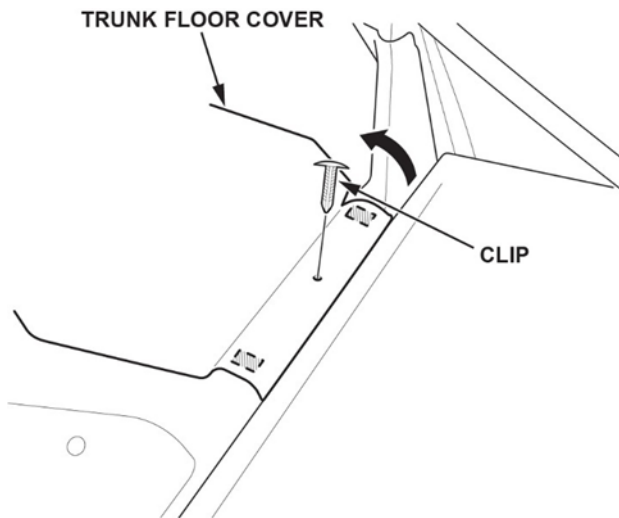

11. Open the trunk lid, then remove the trunk floor cover.



12. Remove the rear floor upper cross-member.

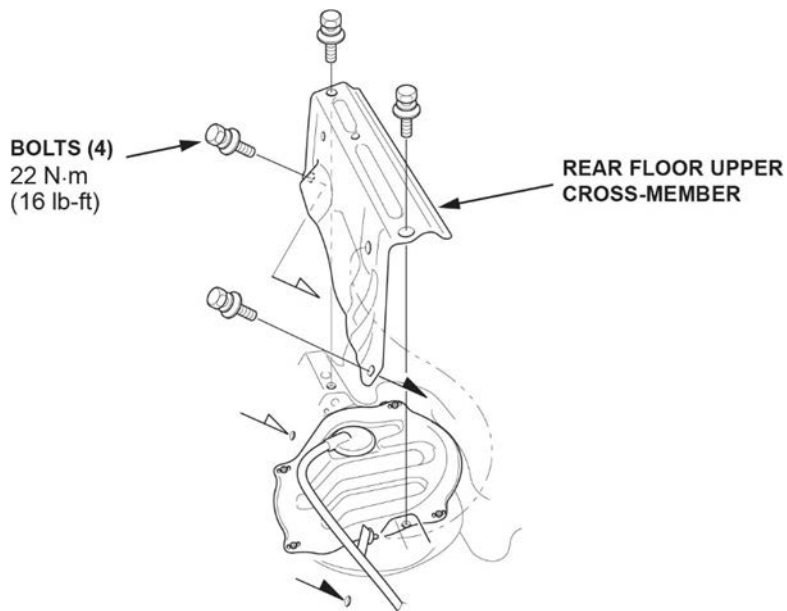

13. Remove the fuel tank unit access panel and disconnect the connector.

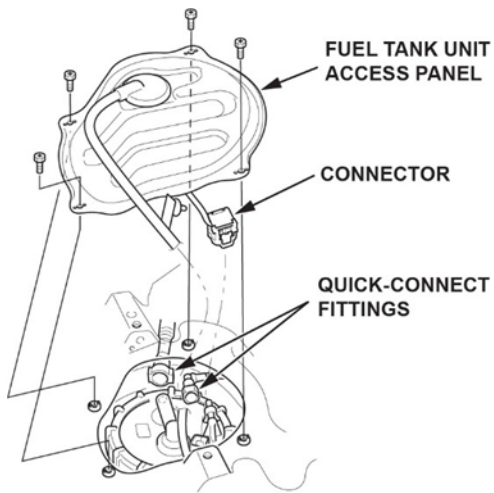

14. Place a rag or shop towel over the quick-connect fittings and disconnect them.

15. Remove the fuel tank unit locknut using the fuel sender wrench (T/N 07AAA-SNA0100) as shown.

NOTE:

- Keep the fuel sender wrench from floating.
- After unlocking the fuel tank unit cam lock ring, clean the top of the fuel pump flange and adjacent areas to make sure it's free of dirt, dust, and debris.

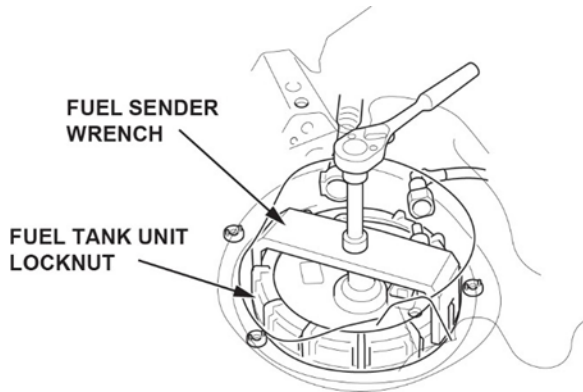

16. Remove the fuel tank unit.

NOTE: Do not bend or twist the fuel level sensor arm excessively. This may damage the fuel level sensor or cause it to send inaccurate readings.

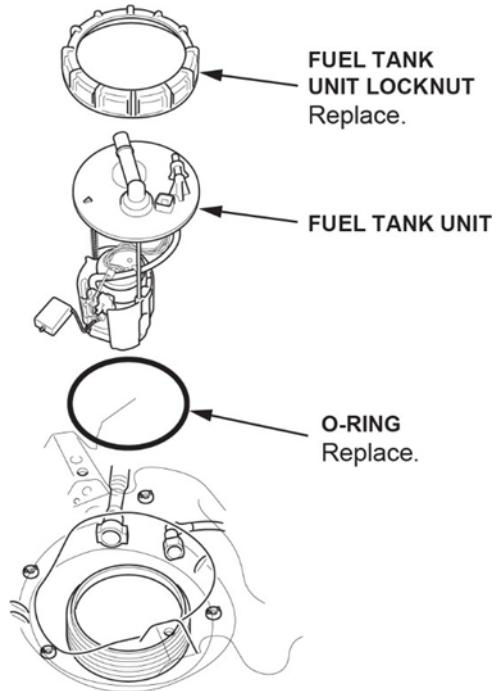

17. Prepare the fuel pump and parts to be replaced.

NOTE: Take a photo of the fuel tube and wire harness and note their routing for assembly. There are various types of routing.

18. Spread the wire harness clamps and remove the wire harness. Make sure not to damage the wire harness.

NOTE: Do not spread the clamps too wide. Spreading them too wide may damage them.

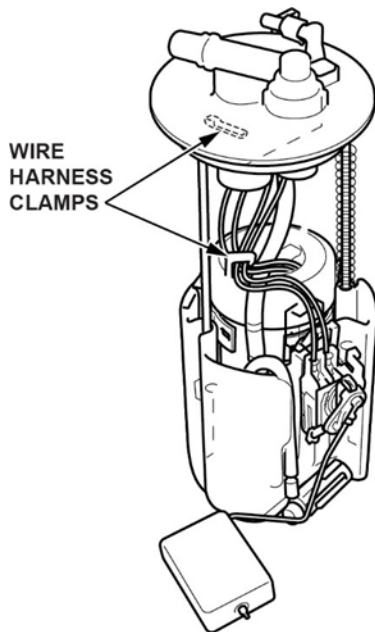

19. Press the tab on the fuel level sensor to release the lock. Then, push up on the fuel level sensor.

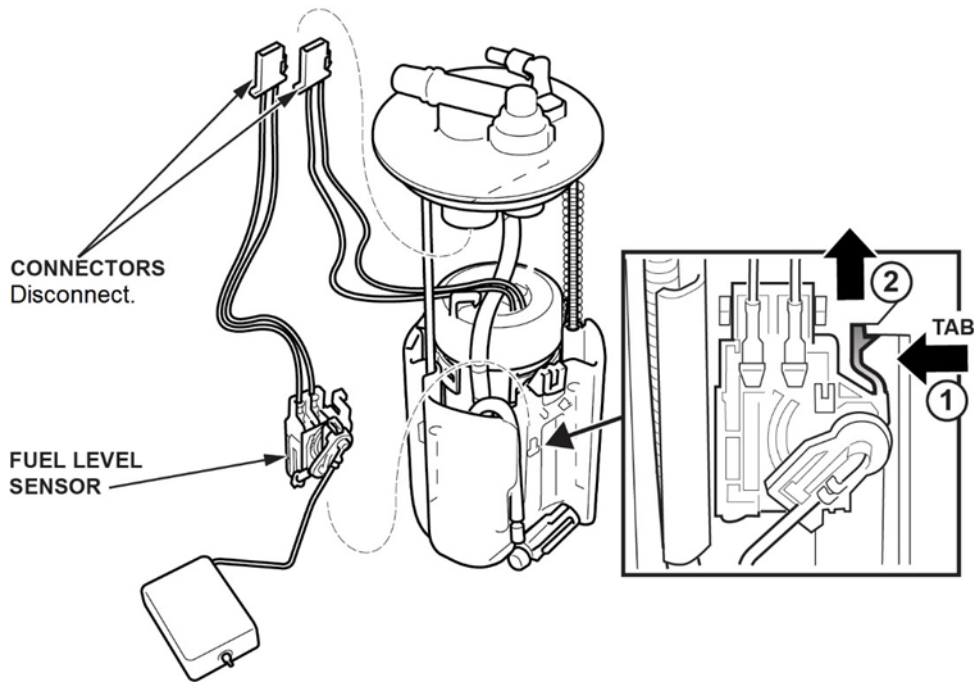

20. Disconnect the fuel level sensor harness and remove the fuel level sensor from the fuel tank unit.

21. Remove the E-rings and discard them.

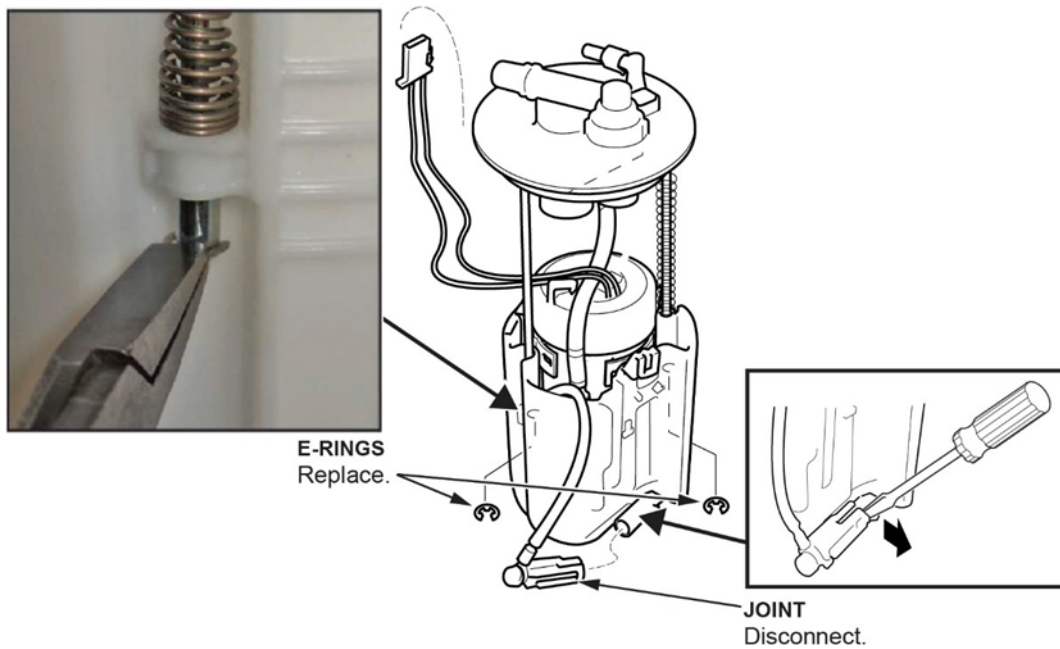

22. Disconnect the joint at the bottom of the reservoir.

23. Remove the fuel filter assembly from the reservoir by releasing the three clips.

NOTE:

- Do not spread the clips too wide. Spreading them too wide may damage them.
- The spring may slide off the sliding shaft. Retain this spring. It will be used during assembly.

24. Release the three clips at the base of the fuel pump assembly and remove it from the fuel filter.

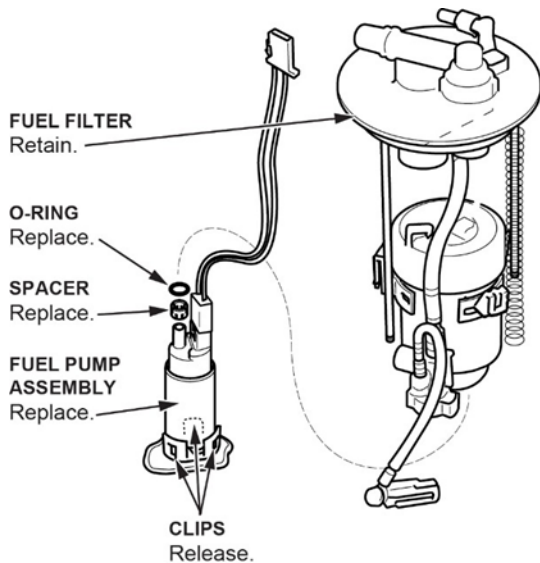

25. Pull the fuel pump assembly out of the fuel filter.

NOTE: If the O-ring remains on the fuel filter, use a flat-tip screwdriver wrapped in protective tape to remove it. Make sure not to damage the O-ring seat section.

26. Install the new spacer onto the new fuel pump motor.

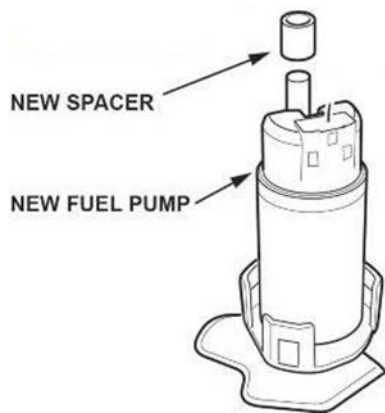

27. Install the new O-ring, then lubricate ONLY the outside edge of it, using clean engine oil.

NOTE: Do not pinch the O-ring during installation.

NEW O-RING

Lubricate after installing.
Do not lubricate the
inside of the o-ring.

NEW SPACER

NEW FUEL PUMP

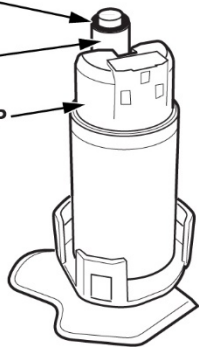

28. Install the new harness and make sure the connection is secure and the connectors are firmly locked into place.

NEW O-RING

Lubricate after installing.
Do not lubricate the
inside of the o-ring.

NEW SPACER

NEW FUEL PUMP

NEW HARNESS

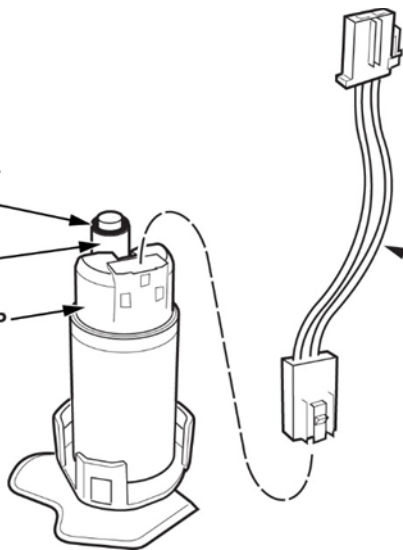

29. With the palm of your hands press the fuel pump into the suction fuel filter.

[▶ PLAY VIDEO](#)

Click here to view the video:

NOTICE

When pressing the fuel pump into the suction filter, make sure you do so with a single firm push. Failure to do so may damage the O-ring. If it is seated properly, you will hear a click.

If you do not hear the click, remove all parts and inspect the O-ring for damage. If the O-ring is damaged, it must be replaced. Reassemble using the above process.

NOTE:

- When inserting the pump, be careful not to break the suction filter.
- If the O-ring is damaged, replace it with a new one.
- After installing the fuel pump to the suction filter, make sure the clips are firmly attached to the new fuel pump.

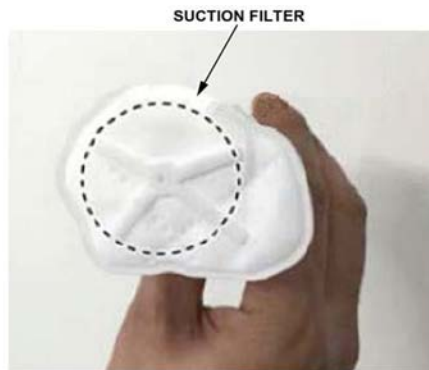

GOOD



NO GOOD



30. Install the fuel filter assembly to the reservoir:

31. Install the new O-ring, then lubricate the outside edge of it, using only clean engine oil.

NOTE:

- Coat the O-ring with clean engine oil; do not use any other oil or fluid.
- Do not pinch the O-ring during installation.
- Insert the spring into the sliding shaft, and make sure it is lined up when installing the fuel filter.
- Make sure the fuel tube is routed exactly as shown in the photo taken before disassembly.
- Make sure the three clips are fully engaged.

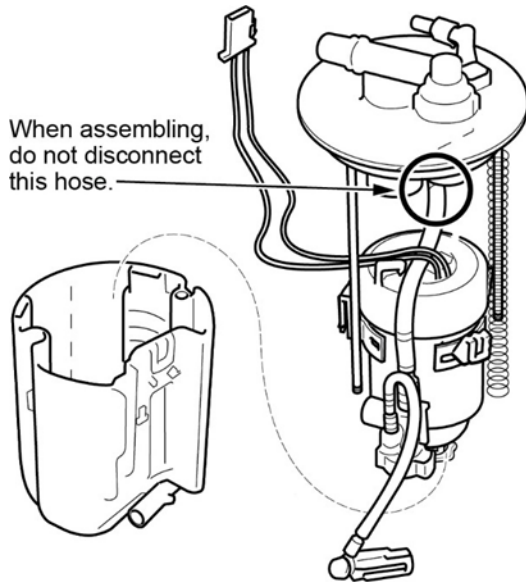

32. Install the new E-rings.

NOTE: After installation, make sure the E-rings can be rotated with your finger. If they cannot be rotated, the E-rings may not be fully seated or may be incorrectly installed.

33. Install the fuel level sensor to the reservoir. Make sure the lock is engaged, and the connection is secure.

NOTE: Do not bend or twist the fuel level sensor arm excessively. This may damage the fuel level sensor or cause it to send inaccurate readings.

34. Install the wiring harness to the clamps.

NOTE:

- Do not spread the clamps too wide. Spreading them too wide may damage them.
- Clip in the smaller harness wires followed by the larger wires.
- Make sure not to damage the wire harness.
- Make sure to route the wire harness exactly as shown in the photo taken before disassembly.

HARNESS ROUTING:

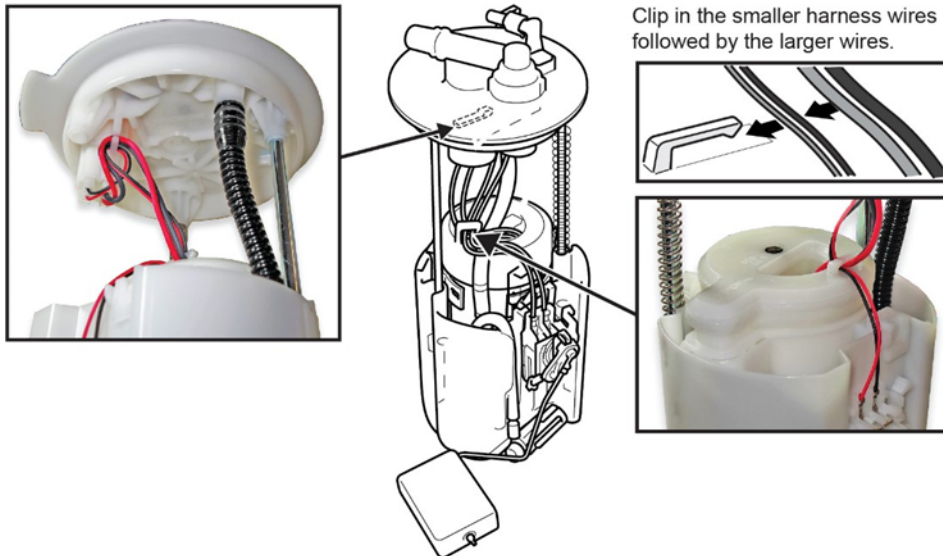

35. While compressing the fuel tank unit, make sure the movement is smooth and the fuel tube and wiring harness do not stretch, pinch, or bind.

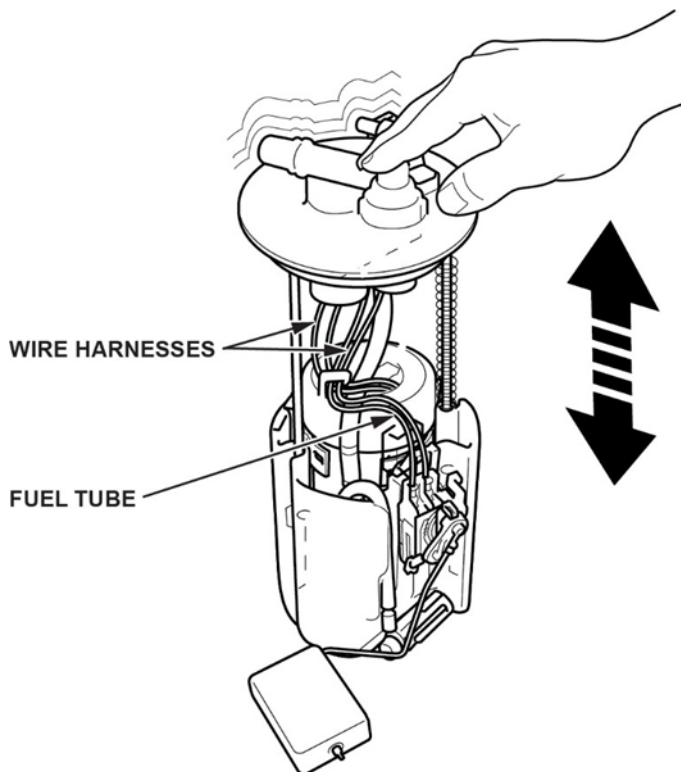

36. Install the new O-ring to the fuel tank, then partially install the new fuel tank unit.

NOTE:

- Do not bend or twist the fuel level sensor arm excessively. This may damage the fuel level sensor or cause it to send inaccurate readings.
- Before installing the new O-ring, clean the fuel tank around the fuel pump opening where the O-ring will seat. The tank opening must be free of dirt, dust, and debris.
- Be careful not to damage the O-ring.
- Do not coat the O-ring with any oil.

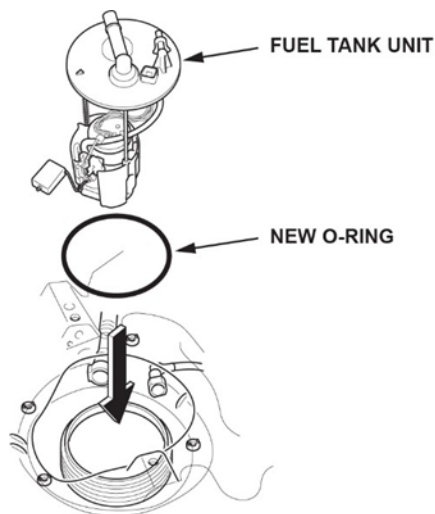

37. Line up the mark on the fuel tank unit to the marks on the fuel tank, then insert the fuel tank unit into the fuel tank.

NOTE: To avoid any leaks, check the O-ring, either visually or by hand, to make sure it is not pinched.

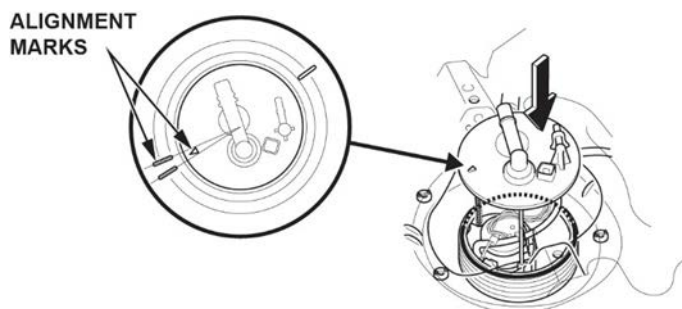

38. Press down on the fuel tank unit while turning the locknut clockwise by hand.

39. Using the fuel nut wrench, tighten the locknut to **125 N·m (92 lb-ft)**.

NOTE:

- During installation, check the O-ring, either visually or by hand, to make sure it is not pinched.
- After tightening, make sure the mark on the fuel tank unit is still lined up with the marks on the fuel tank.

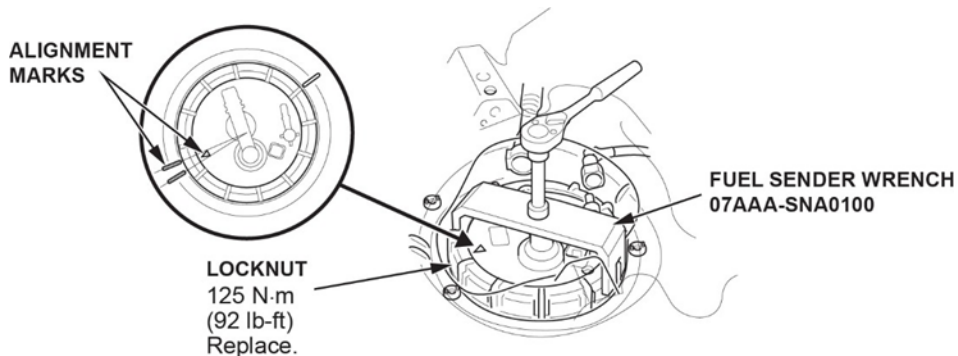

40. Remove the quick-connect fitting retainer from the fuel tank unit, then install a new retainer onto the quick connect fitting.

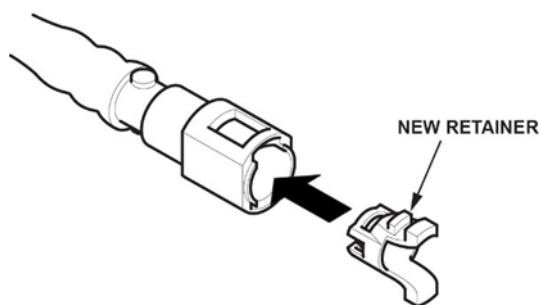

41. Connect the fuel line quick-connect fitting.

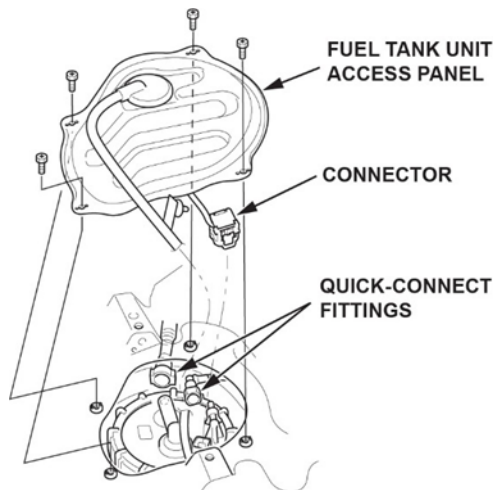

42. Connect the fuel tank unit connector.

43. Connect the 12-volt battery terminals **6.9-11.8 N·m (5.1-8.7 lb-ft)**.

44. Turn the ignition to ON, but do not turn the engine on. The fuel line will be pressurized after the fuel pump runs for about **2 seconds**. Repeat these two or three times, then make sure there is no fuel leakage.

- 45. Install the fuel tank unit access panel.
- 46. Install the remaining parts in the reverse order of removal.
- 47. Clear all DTCs using an i-HDS.
- 48. California residents only: Fill out a Vehicle Emissions Recall – Proof of Correction certificate and use **UGO** as the recall number. Have the service consultant give the certificate to your client and advise him or her to keep it as proof that the recall was completed. Your client will need to submit this certificate to the DMV only if the DMV requests it. If you need more certificates, use reorder number Y0657.

Vehicle Emission Recall - Proof of Correction				
License Number	Make	Year Model	Body Type	Vehicle Identification Number <div style="border: 1px solid black; display: flex; justify-content: space-between; height: 20px;"> 1234567891011121314151617181920 </div>
Manufacturer _____			Recall Number UGO	
<p>The above described vehicle has been repaired, modified and/or equipped with emission control devices to meet applicable California Emission Control Laws.</p>				
Dealer's Name		Address, City, State and Zip		
Date		Dealership's Authorized Signature		
		X		
Return this certificate to DMV only when required - otherwise retain for your records.				

Y0657 ACL 24832 (0212)