

Safety Recall: 2018–19 Civic Fuel Pump Motor VINs Starting With JHM

AFFECTED VEHICLES

Year	Model	Trim Level	VIN Range
2018–19	Civic 4-door	All except Si	Check the iN VIN status for eligibility. (Only VINs that start with JHM)

BACKGROUND

On December 18, 2023, American Honda notified NHTSA of its intention to initiate a **STOP SALE** and **safety recall** for a certain number of 2018–19 Civic with VIN's starting with JHM in order to replace the fuel pump motor manufactured with defective impellers.

Due to swelling of the fuel pump motor impeller, the fuel pump may seize and stop working. A defective impeller may cause the fuel pump to become inoperative, which could prevent an engine from functioning as intended. This limitation may cause a loss of motive power or a stall while being driven, increasing the risk of a crash or injury, creating a safety hazard.

If this bulletin appears during an iN VIN status inquiry, the vehicle is subject to a **safety recall**. Any affected vehicles in your dealer inventory are on **STOP SALE** until further notice. Refrain from calling Tech Line for updates.

CUSTOMER NOTIFICATION

Owners of the affected vehicles will be sent a notification of this campaign. They will be informed that due to a limited supply of parts (at this time) Honda is **prioritizing** the repair of customer vehicles experiencing symptoms related to this recall.

When **adequate replacement parts** become available, Honda will send a follow-up letter to customers instructing them to schedule an appointment for all vehicles affected by this recall. If a customer experiences the known symptoms associated with this **safety recall** (see CORRECTIVE ACTION), they are instructed to contact their local Honda dealer for the repair.

For any questions or concerns customers may have, you may have them contact American Honda Customer Support & Campaign Center at **1-888-234-2138**.

The following suggested text should be included on any repair order for an already sold affected vehicle that comes in for service. This information should be printed out completely any time service is conducted on an affected vehicle, and the recall repair has not yet been completed. Depending on parts availability, the normal procedures under SOM 7.2.1 will apply for this recall.

Suggested Verbiage to be Included on the Repair Order

Customer was advised that:

The vehicle is subject to a recall affecting the fuel pump motor. The parts necessary to complete the recall repair are currently limited. Vehicles with eligible VINs and the following symptoms: difficulty starting, engine hesitation while driving, and/or an illuminated check engine light displayed with DTC P0087, are eligible for immediate repair. Once parts repair kits are available, if the vehicle has not been repaired, the registered owner of the vehicle will receive a notice to bring the vehicle in for a replacement of the components, regardless of symptom.

CUSTOMER INFORMATION: The information in this bulletin is intended for use only by skilled technicians who have the proper tools, equipment, and training to correctly and safely maintain your vehicle. These procedures should not be attempted by "do-it-yourselfers," and you should not assume this bulletin applies to your vehicle, or that your vehicle has the condition described. To determine whether this information applies, contact an authorized Honda automobile dealer.

IMPORTANT NOTICE

Vehicles that are both shown as an eligible VIN and experiencing the following symptoms will be prioritized for repair: difficulty starting, engine hesitation while driving, and/or an illuminated check engine light displayed with DTC P0087 (Fuel Rail Pressure Too Low) stored.

CORRECTIVE ACTION

Replace the fuel pump motor.

NOTE: If the vehicle has any of the symptoms listed in BACKGROUND, you must apply this bulletin before attempting any other repairs. If the symptoms remain after the recall repair is complete, only attempt further repairs (such as replacing the high-pressure fuel pump) after authorized troubleshooting.

PARTS INFORMATION

NOTE:

- Due to a limited supply, parts will be allocated to your dealership **based on availability**.
- Prioritize repairing customer vehicles that meet both the VIN status eligibility and exhibit a known symptom such as: difficulty starting, engine hesitation while driving, and/or an illuminated check engine light with DTC P0087 (Fuel Rail Pressure Too Low).

Part Name	Part Number	Quantity
Fuel Pump Motor Kit	06170-TED-306	1

For dealers experiencing a strong fuel smell from storing a fuel pump motor replaced under this service bulletin, the fuel pump motor may be disposed of immediately in accordance with local regulations. This only applies to the fuel pump motor replaced under this service bulletin. The published retention policy remains in effect for all other parts.

If you have any questions about this exception or other parts retention issues, contact the WPI Administrative Office at **937-642-2737**.

TOOL INFORMATION

Tool Name	Part Number	Quantity
Fuel Sender Wrench	070AA-TLA0100	1

WARRANTY CLAIM INFORMATION

Operation Number	Description	Flat Rate Time	Defect Code	Symptom Code	Template ID	Failed Part Number
3101EH	Replace the fuel pump motor and do the VSA sensor neutral position memorization procedure.	1.3 hr	6FE00	UH800	A24077A	17045-TEG-A01

Skill Level: Repair Technician

REPAIR PROCEDURE

⚠ WARNING

Fuel pump motor removal exposes fuel, which can ignite, causing a fire or explosion.

This can cause serious injury or death.

Always work in a well-ventilated area and keep sparks or open flames away.

1. Insert the emergency fuel fill funnel into the fuel filler neck to relieve the pressure in the fuel tank. NOTE: The emergency fuel fill funnel is in the trunk toolbox.

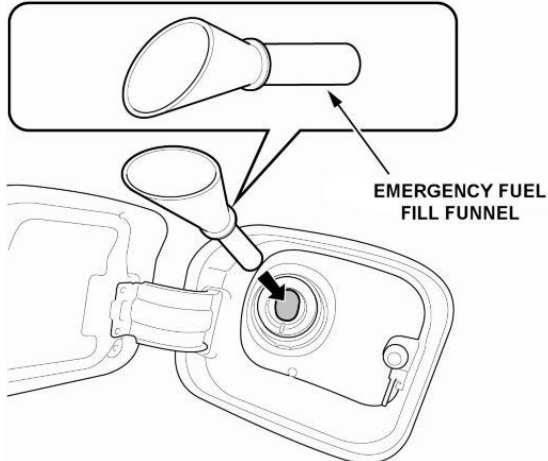

2. Remove the PGM-FI main relay 2.

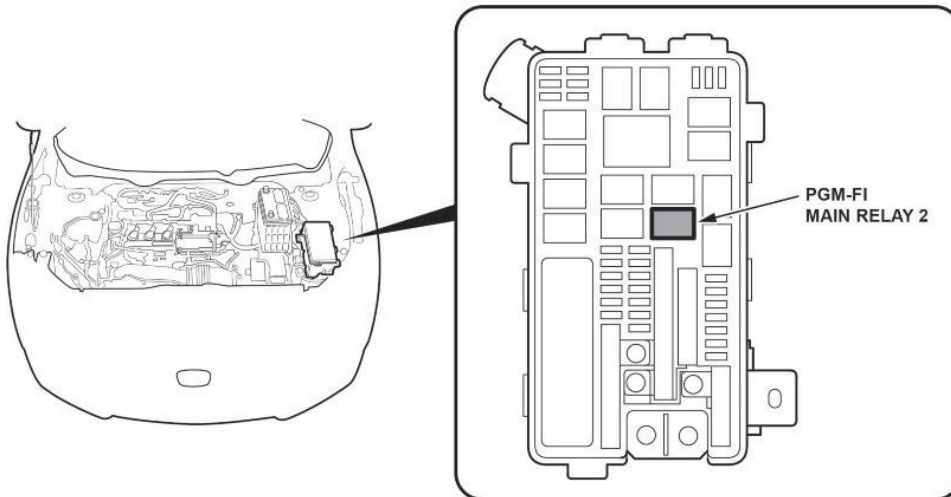

3. Start the engine and let it idle until it stalls.
4. Turn the ignition to OFF.
5. Install the PGM-FI main relay 2.

6. Disconnect both 12-volt battery terminals.

NOTICE

To protect the terminal connector from damage, do not hold it when removing the negative terminal.

NOTE:

- Always disconnect the negative terminal first.
- Do not disconnect the 12-volt battery sensor from the cable.

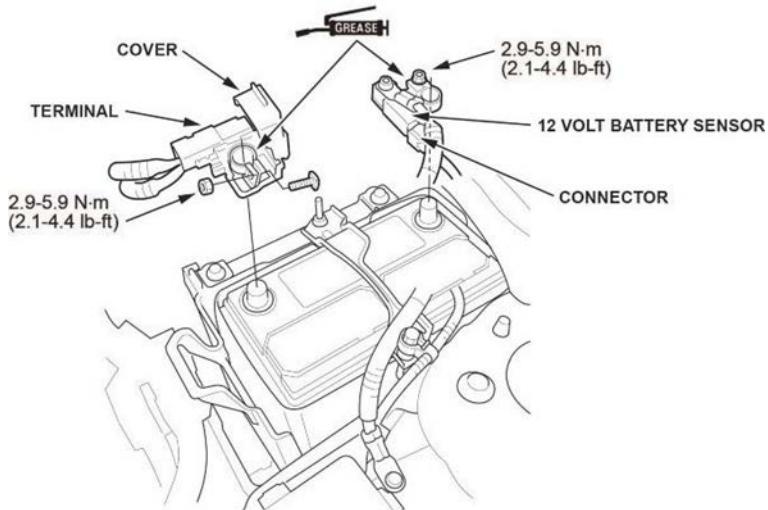

7. Remove the rear seat cushion bolt.

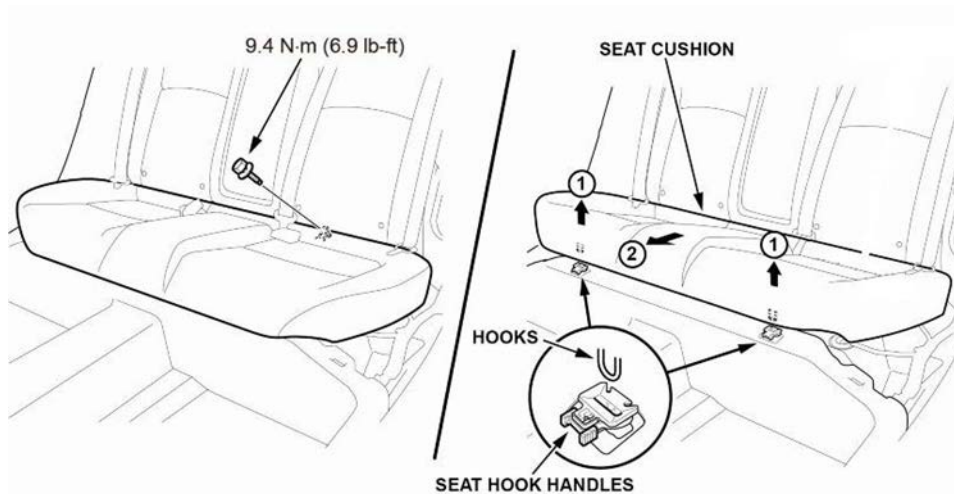

8. While pushing down on the seat cushion, pull the seat hook handles to release the hooks.

9. Remove the rear seat cushion.

10. Fold down the right-rear seat-back.

11. Turn over the bottom of the right-rear seat-back cover, then remove the bolts.

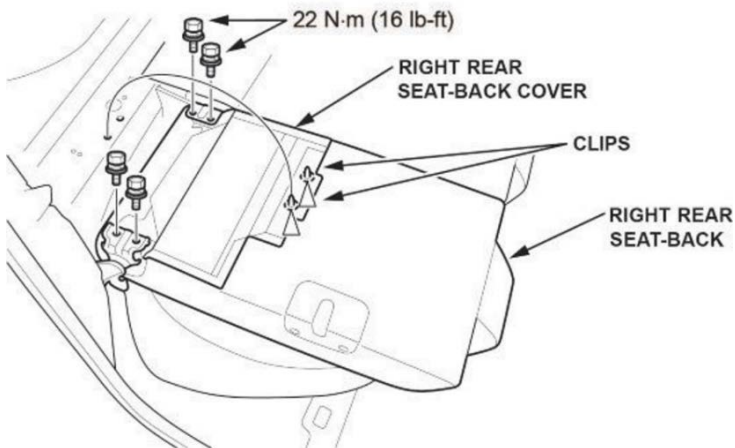

12. Remove the right-rear seat-back.

13. Fold down the left-rear seat-back.

14. Turn over the bottom of the left-rear seat-back cover, then remove the bolts.

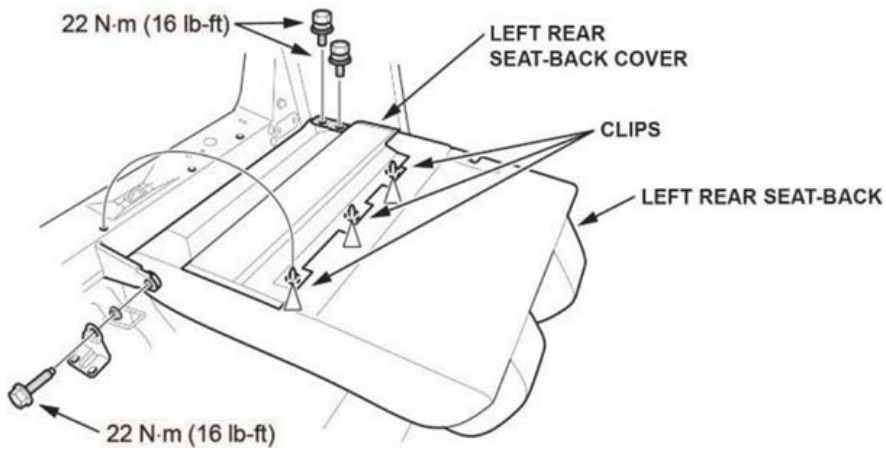

15. Remove the left rear seat-back.

16. Remove the center rear seat belt lower anchor bolt.

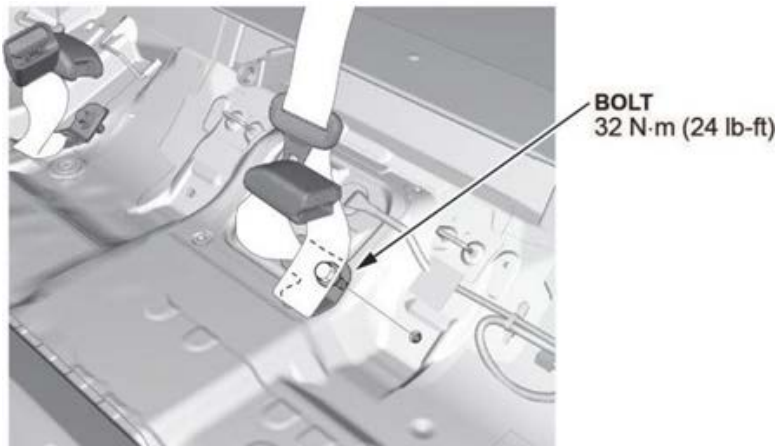

17. Remove the fuel tank unit access panel and disconnect the connector.

18. Disconnect the quick connect fitting from the fuel tank unit.

NOTE: Remove the fuel connector cover if necessary.

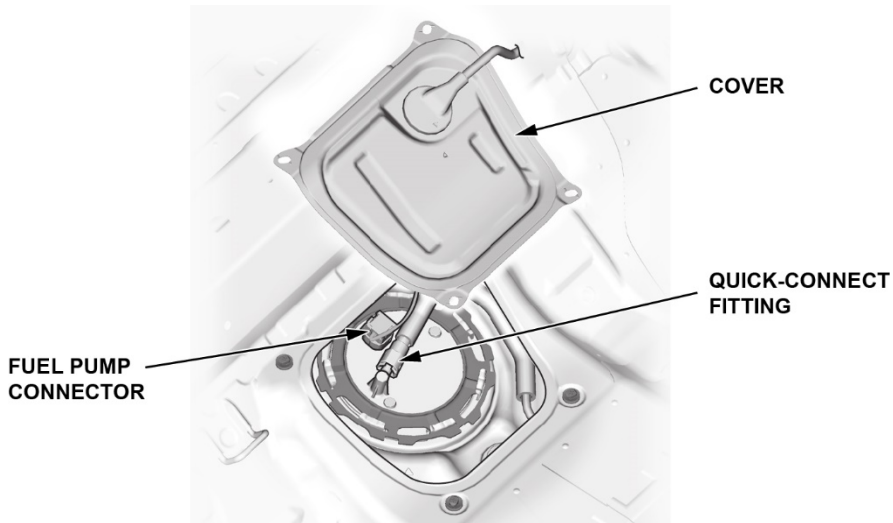

19. Lift the front of the vehicle.

NOTICE

If the fuel level is showing 90% or more, the front of the vehicle must be raised more than 345 mm (13.58 in) to prevent fuel spillage when the fuel tank unit is removed. Make sure the vehicle is securely supported when raised.

20. Unlock the fuel tank unit cam lock ring using the fuel sender wrench (T/N 070AA-TLA0100).

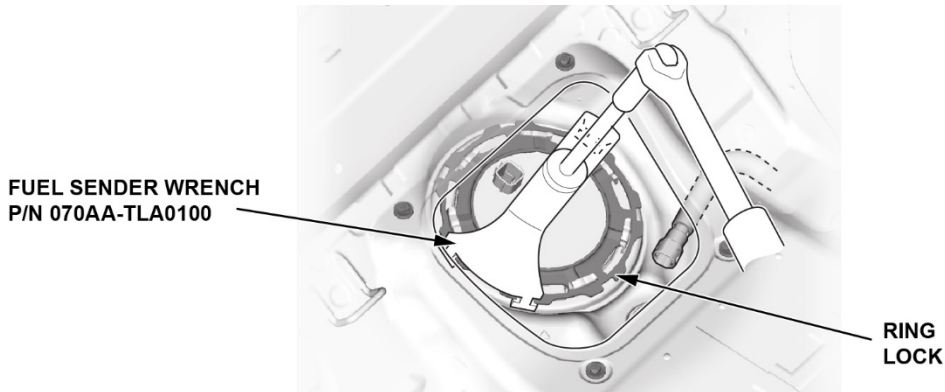

21. Set the fuel sender wrench as shown, and make sure it does not float while turning.

22. Turn the fuel tank unit cam lock ring counterclockwise and remove the lock ring.

NOTE: After unlocking the fuel tank unit cam lock ring, clean the top of the fuel pump flange and adjacent areas to make sure it's free of dirt, dust, and debris.

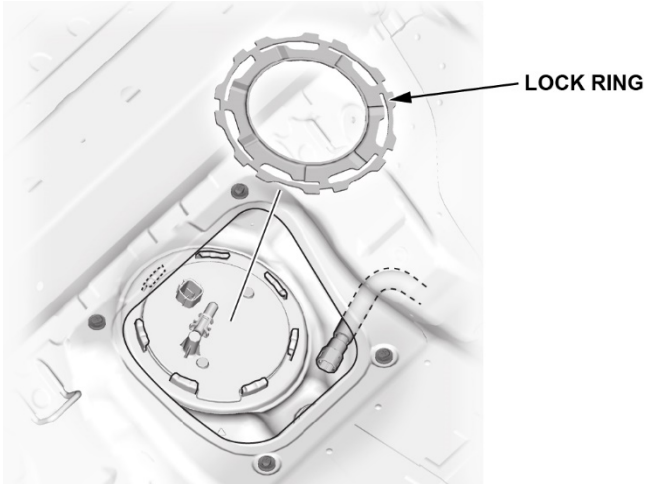

23. Remove the fuel tank unit with the O-ring.

NOTICE

Do not to bend or twist the fuel level sensor arm excessively. This may damage the fuel level sensor or cause it to send inaccurate readings.

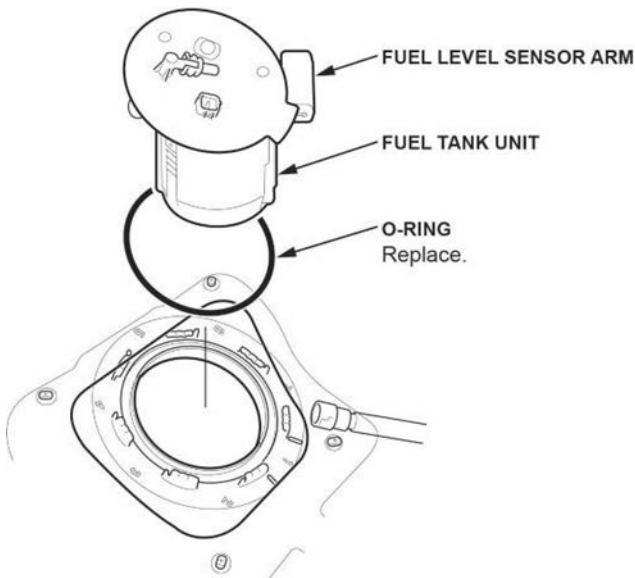

24. Prepare the fuel tank unit and parts to be replaced.

NOTE: Take a photo of the fuel tube and wire harness and note their routing for assembly. There are various types of routing.

25. Spread the wire harness clamps and remove the wire harness. Make sure not to damage the wire harness.

NOTICE

Do not spread the clamps too wide. Spreading them too wide may damage them.

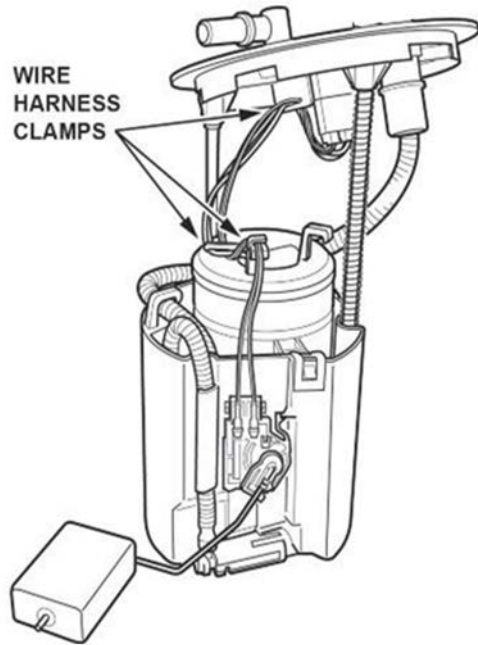

26. Press the tab on the fuel level sensor to release the lock. Then, push up on the fuel level sensor.

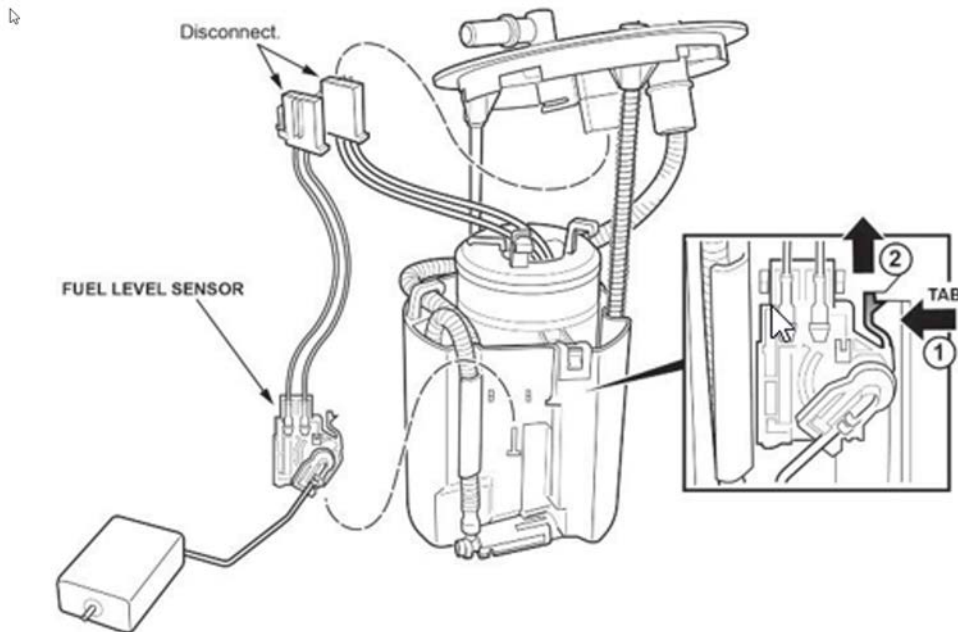

27. Disconnect the fuel level sensor harness and remove the fuel level sensor from the fuel tank unit.

28. Remove the E-ring and discard it.

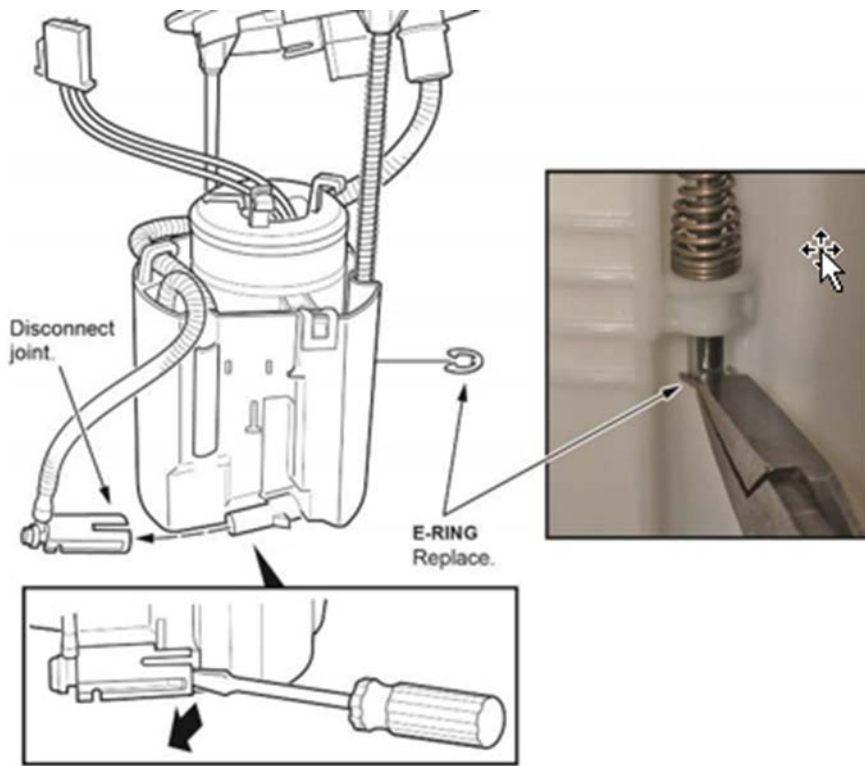

29. Disconnect the joint at the bottom of the reservoir.

30. Remove the fuel filter assembly from the reservoir by releasing the three clips.

NOTICE

Do not spread the clips too wide. Spreading them too wide may damage them.

NOTE: The spring may slide off the sliding shaft. Retain this spring. It will be used during assembly.

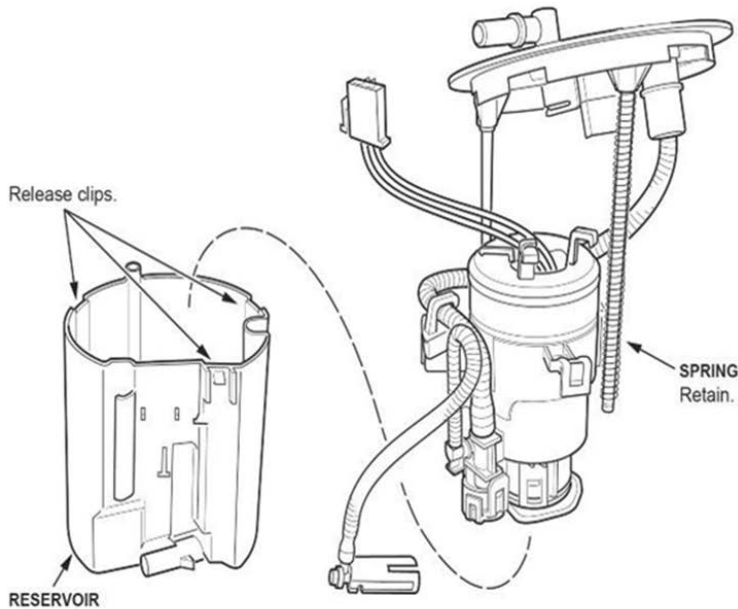

31. Release the three clips at the base of the fuel pump assembly and remove it from the fuel filter.

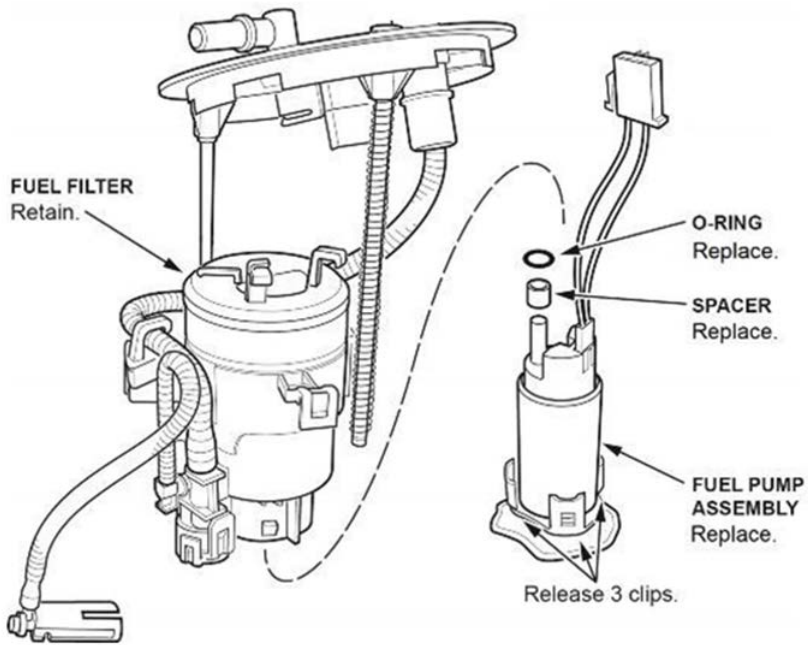

32. Install the new spacer onto the new fuel pump motor.

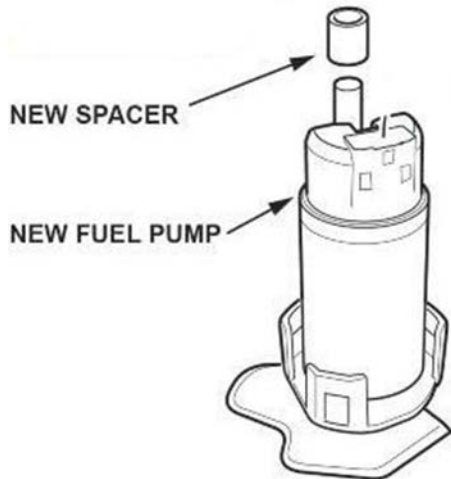

33. Install the new O-ring, then lubricate ONLY the outside edge of it, using clean engine oil.

NOTE: Do not pinch the O-ring during installation.

NEW O-RING

Lubricate after installing.

Do not lubricate the inside of the o-ring.

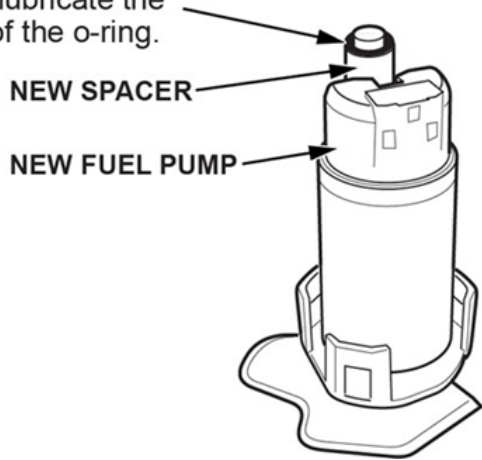

34. Install the new harness, making sure the connection is secure and the connectors are firmly locked into place.

NEW O-RING

Lubricate after installing.

Do not lubricate the inside of the o-ring.

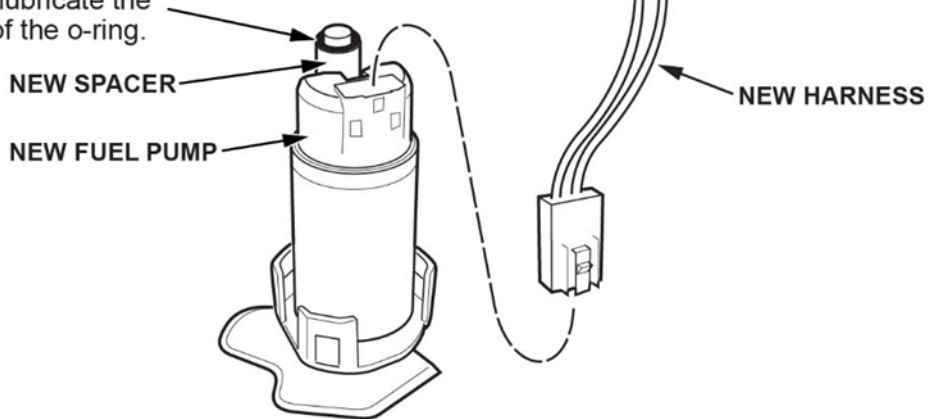

35. With the palm of your hands press the fuel pump into the suction fuel filter.

[▶ PLAY VIDEO](#)

Click here to view the video:

When pressing the fuel pump into the suction filter make sure you do so with a single firm push. Failure to do so may damage the O-ring. If it is seated properly, you will hear a click.

If you do not hear the click, remove all parts and inspect the O-ring for damage. If the O-ring is damaged, it must be replaced. Reassemble using the above process.

NOTE:

- When inserting the pump, be careful not to break the suction filter.
- If the O-ring is damaged; replace it with a new one.
- After installing the fuel pump to the suction filter, make sure the clips are firmly attached to the new fuel pump.

SUCTION FILTER



GOOD



NO GOOD

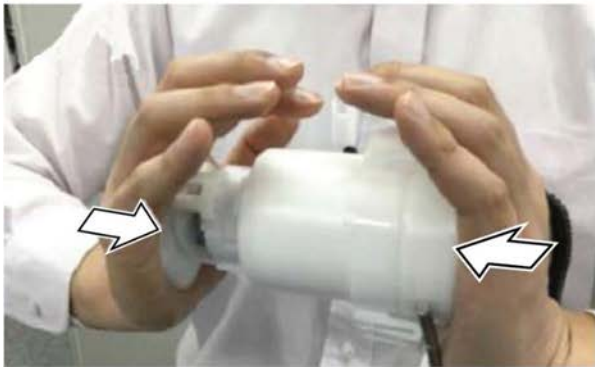

36. Install the fuel filter assembly to the reservoir.

NOTE:

- Insert the spring into the sliding shaft, and make sure it is lined up when installing the fuel filter.
- Make sure to route the fuel tube exactly as shown in the photo taken before disassembly.
- Make sure the three clips are fully engaged.

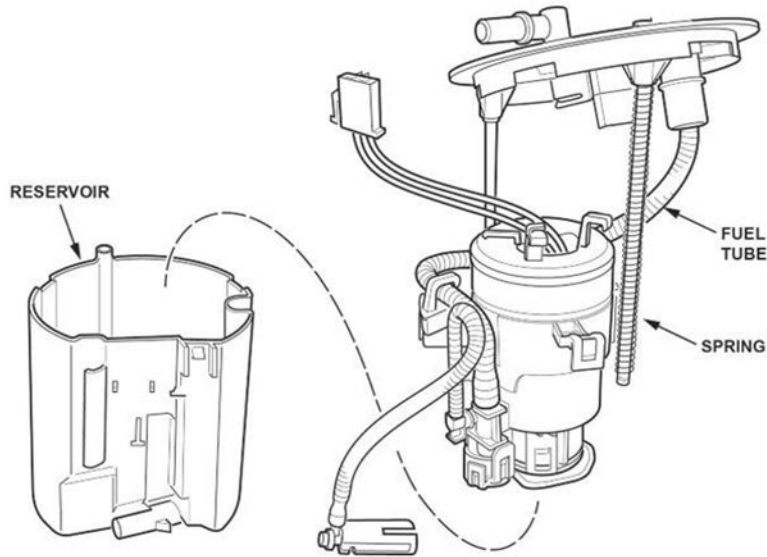

37. Install the new E-ring.

NOTE: After installation, make sure the E-ring can be rotated with your finger. If it cannot be rotated, the E-ring may not be fully seated or may be incorrectly installed.

38. Install the fuel level sensor to the reservoir. Make sure the lock is engaged and the connection is secure.

NOTICE

Do not to bend or twist the fuel level sensor arm excessively. This may damage the fuel level sensor or cause it to send inaccurate readings.

39. Install the wiring harness to the clamps.

NOTICE

Do not spread the clips too wide. Spreading them too wide may damage them.

NOTE:

- Clip in the smaller harness wires followed by the larger wires.
- Make sure not to damage the wire harness.
- Make sure to route the wire harness exactly as shown in the photo taken before disassembly.

HARNESS ROUTING:

Clip in the smaller harness wires followed by the larger wires.

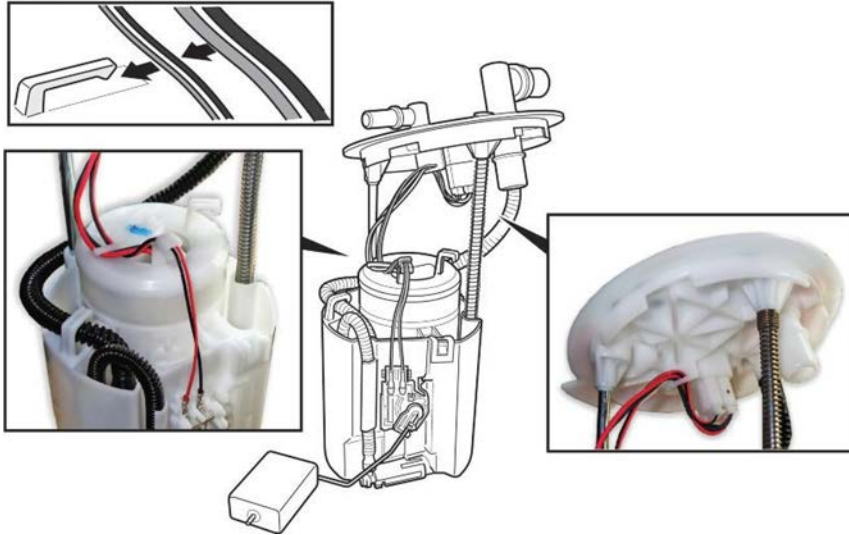

40. While compressing the fuel tank unit, make sure the movement is smooth and the fuel tube and wiring harness do not stretch, pinch, or bind.

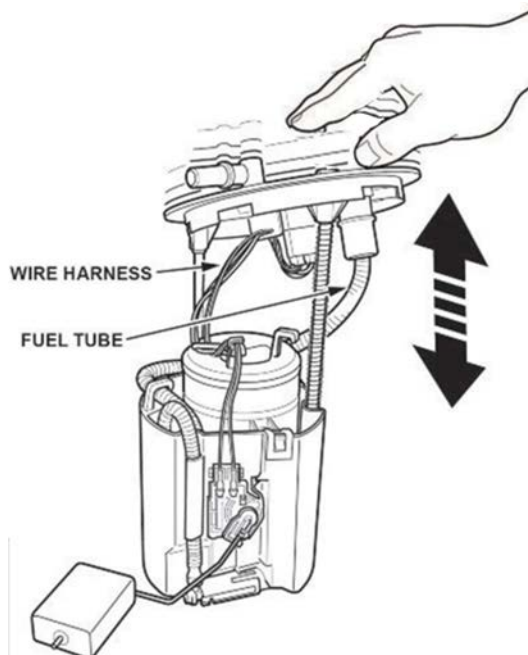

41. Install a new O-ring on the fuel tank.

NOTE:

- Before installing the new O-ring, clean the fuel tank around the fuel pump opening where the O-ring will seat. The tank opening must be free of dirt, dust, and debris.
- Be careful not to damage the O-ring.
- Do not coat the O-ring with any oil.

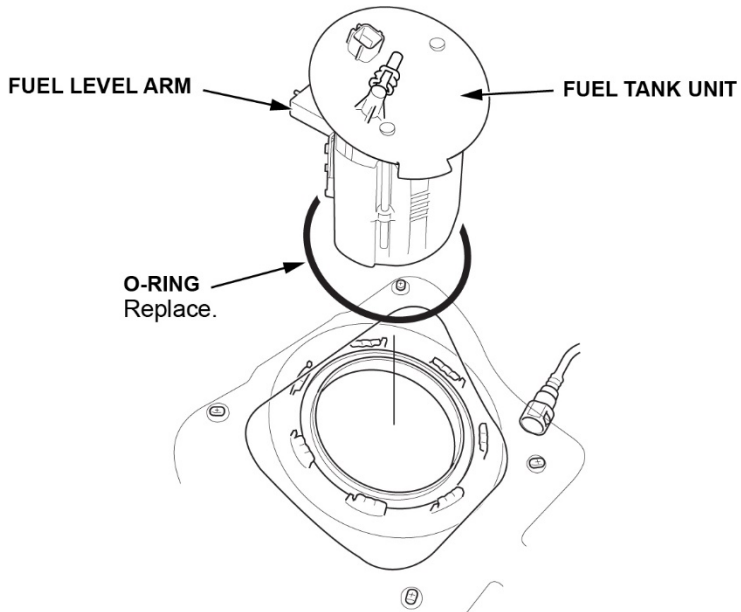

Do not to bend or twist the fuel level sensor arm excessively. This may damage the fuel level sensor or cause it to send inaccurate readings.

42. Line up the tab of the fuel tank unit as shown, and partially install the new fuel tank unit cam lock ring with a new O-ring.

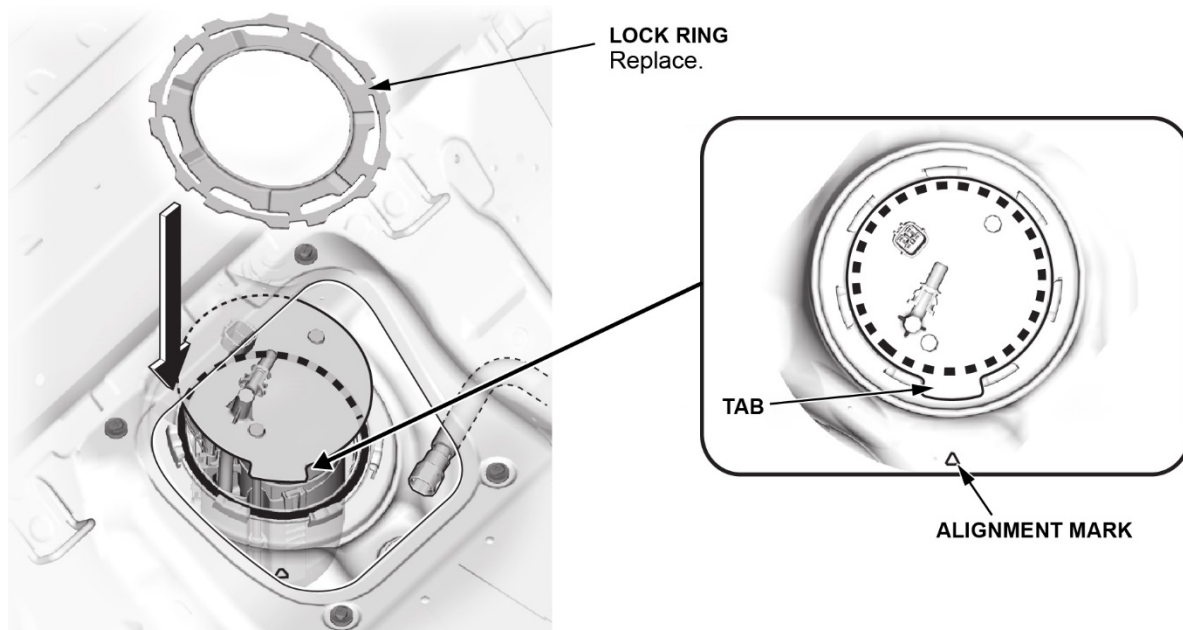

43. Turn the fuel tank unit cam lock ring by hand and slide the fuel tank unit cam lock tabs to the positioning edge as shown.

NOTICE

Make sure the fuel cam lock ring is not floating. If the cam lock ring is not properly installed, the fuel tank can be damaged and will require replacement.

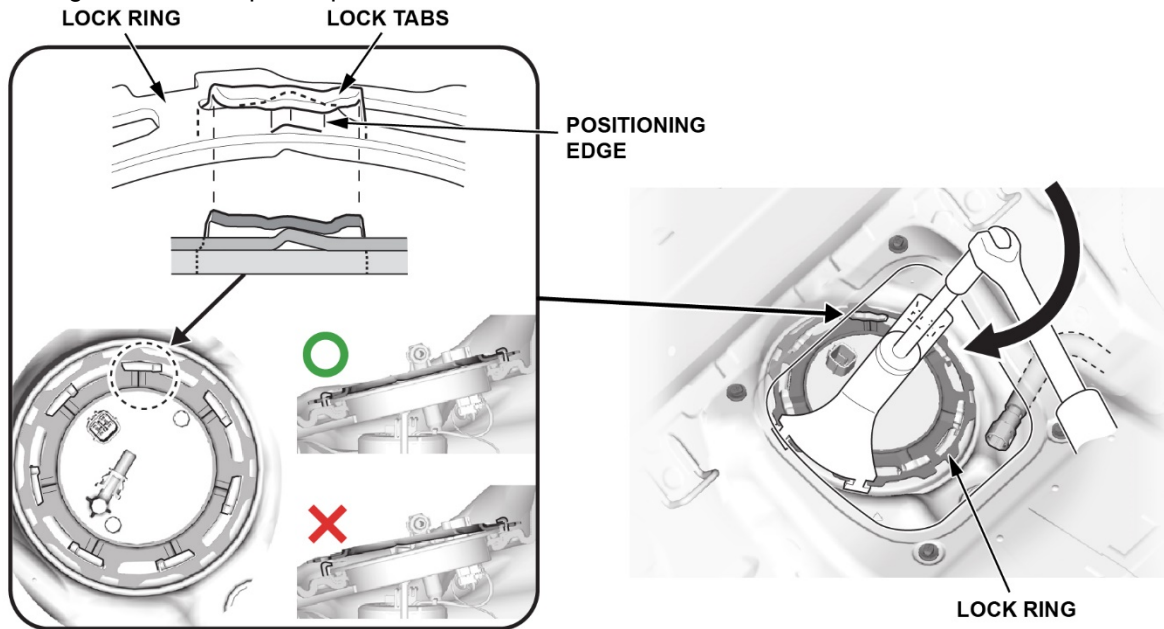

44. Tighten the fuel tank unit cam lock ring by turning clockwise using the fuel sender wrench (070AA-TLA0100).

NOTE:

- Keep the fuel sender wrench from floating.
- Securely set the positioning edge of the fuel tank to the tabs on the cam lock ring as shown.

45. If the retainer has been removed from the line install a new retainer.

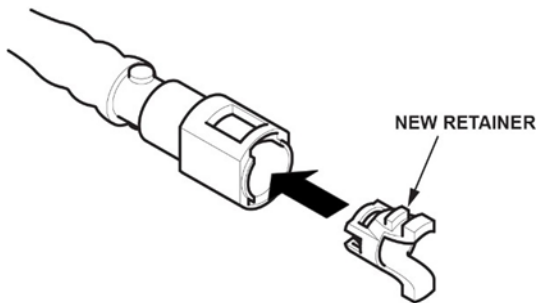

46. Connect the fuel line quick-connect fitting and connector.

NOTE: Install the connector cover if it was removed.

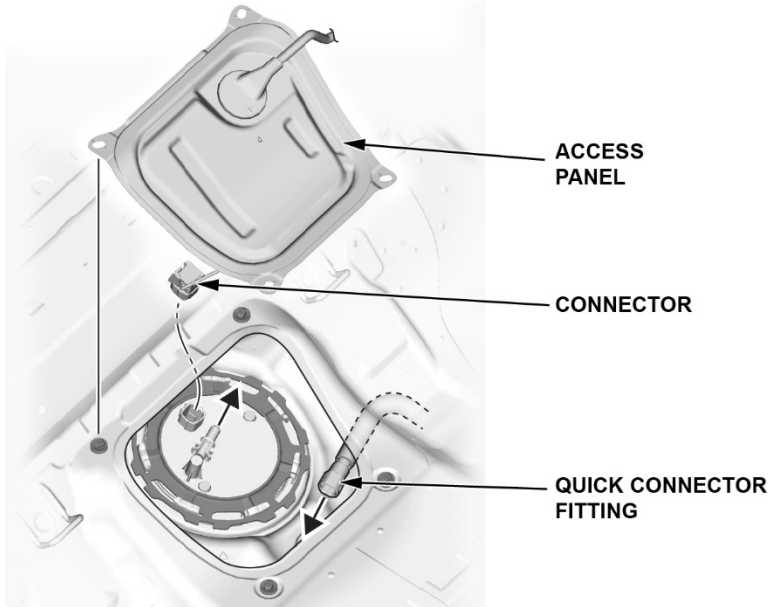

47. Connect the 12-volt battery terminals and torque to **2.9–5.9 N·m (2.1–4.4 lb-ft)**.

48. Turn the ignition to ON, but do not turn the engine on. After the fuel pump runs for about **2 seconds**, the fuel line will be pressurized. Repeat two or three times, then make sure there is no fuel leakage.

49. Install the fuel tank unit access panel.

50. Install the remaining parts in the reverse order of removal.

51. Clear all DTCs using an i-HDS.

52. *California residents only:* Fill out a Vehicle Emissions Recall – Proof of Correction certificate, and use **UH8** as the recall number. Have the service advisor give the certificate to your customer and advise him or her to keep it as proof that the recall was completed. Your customer will need to submit this certificate to the DMV only if the DMV requests it. If you need more certificates, use reorder number **Y0657**.

Vehicle Emission Recall - Proof of Correction				
License Number	Make	Year Model	Body Type	Vehicle Identification Number
Manufacturer			Recall Number UH8	
The above described vehicle has been repaired, modified and/or equipped with emission control devices to meet applicable California Emission Control Laws.				
Dealer's Name		Address, City, State and Zip		
Date	Dealership's Authorized Signature			
	X			
Return this certificate to DMV only when required - otherwise retain for your records.				

Y0657 ACL 24832 (0212)