

February 24, 2025

Version 5

Safety Recall: 2016–21 Pilot Fuel Pump Motor

Supersedes Version 4 dated October 11, 2024, to revise the information highlighted in **yellow**.

APPLIES TO

Year	Model	Trim Level	VIN Range
2016–21	Pilot	ALL	Check the iN VIN status for eligibility.

REVISION SUMMARY

- Under **TOOL INFORMATION**, a tool was added.
- Under **REPAIR PROCEDURE**, step 17 had an image update.

BACKGROUND

A certain number of 2016–21 Pilot units may have been built with a fuel pump motor or may have been repaired with a fuel pump assembly service part with defective impellers.

Due to swelling of the fuel pump motor impeller, the fuel pump may seize and stop working. A defective impeller may cause the fuel pump to become inoperative, which could prevent an engine from functioning as intended. This limitation may cause a loss of motive power or a stall while being driven, increasing the risk of a crash or injury, creating a safety hazard.

If this bulletin appears during an iN VIN status inquiry, the vehicle is subject to a safety recall. Any affected vehicles in your dealer inventory are on STOP SALE until further notice. Refrain from calling Tech Line for updates.

CUSTOMER NOTIFICATION

Owners of affected vehicles will be sent a notification of this campaign. Do an iN VIN status inquiry to make sure the vehicle is shown as eligible. Some vehicles affected by this campaign may be in your new or used vehicle inventory.

Failure to repair a vehicle subject to a recall or campaign may subject your dealership to claims or lawsuits from the customer or anyone else harmed as a result of such failure. To see if a vehicle in inventory is affected by this safety recall, do a VIN status inquiry before selling it.

WARRANTY CLAIM INFORMATION

Operation Number	Description	Flat Rate Time	Defect Code	Symptom Code	Template ID	Failed Part Number
3101EH	Replace the fuel pump motor.	1.3 hr	6FE00	XGL00	A24010A	17045-TZ5-A10

Skill Level: Repair Technician

CUSTOMER INFORMATION: The information in this bulletin is intended for use only by skilled technicians who have the proper tools, equipment, and training to correctly and safely maintain your vehicle. These procedures should not be attempted by “do-it-yourselfers,” and you should not assume this bulletin applies to your vehicle, or that your vehicle has the condition described. To determine whether this information applies, contact an authorized Honda automobile dealer.

PARTS INFORMATION

Refer to the Parts Information Bulletin 24-0016, *Multi-Model Fuel Pump Motor Safety Recall Parts Availability*, for details regarding parts availability and ordering.

Part Name	Part Number	Quantity
Fuel Pump Motor Kit	06170-TZ5-305	1

For dealers experiencing a strong fuel smell from storing a fuel pump motor replaced under this service bulletin, the fuel pump motor may be disposed of immediately in accordance with local regulations. This only applies to the fuel pump motor replaced under this service bulletin. The published retention policy remains in effect for all other parts.

If you have any questions about this exception or other parts retention issues, contact the WPI Administrative Office at **937-642-2737**.

TOOL INFORMATION

Tool Name	Part Number	Quantity
Fuel Sender Wrench	070AA-T0AA100 or 07AAA-T0AA100	1
Fuel Module Separator	07AAF-T5RA100	1

NOTE: 070AA-T0AA100 supersedes 07AAA-T0AA100. If your dealership has 07AAA-T0AA100, it can be used for this repair.

REPAIR PROCEDURE

⚠ WARNING

Fuel pump motor removal exposes fuel, which can ignite, causing a fire or explosion.

This can cause serious injury or death.

Always work in a well-ventilated area and keep sparks or open flames away.

1. Insert the emergency fuel fill funnel into the fuel filler neck to relieve the pressure in the fuel tank.

NOTE: The emergency fuel fill funnel is located in the left rear side trim panel.

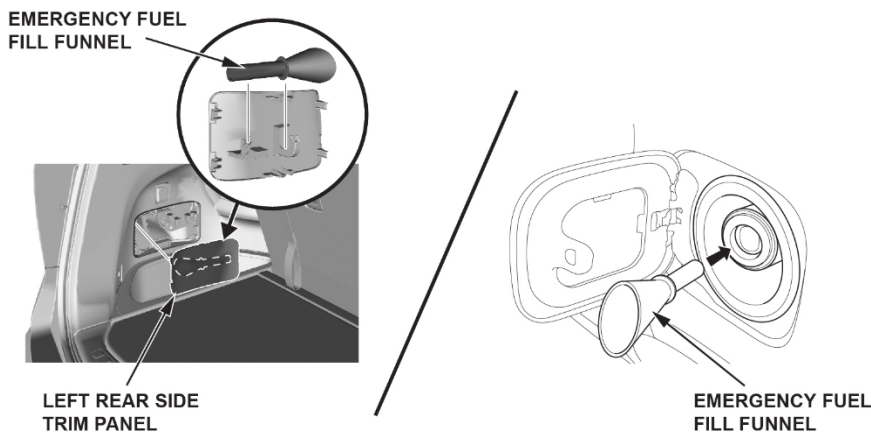

2. Relieve the fuel pressure.

With an i-HDS:

- Connect an i-HDS to the DLC located under the driver's side of the dashboard.

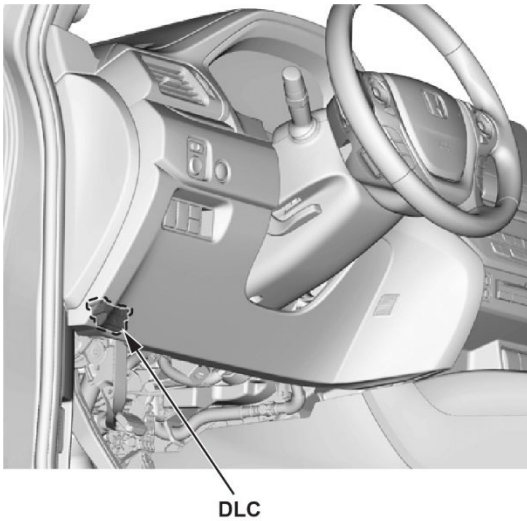

- Turn the ignition to ON.
- Select the **PGM-FI** system on the i-HDS.
- Select **FUEL PUMP OFF** from the **Inspection menu**.
- Start the engine and let it idle until it stalls.

NOTE:

- Do not allow the engine to idle above 1,000 rpm or the PCM will continue to operate the fuel pump.
- A Pending or Confirmed DTC may be set during this procedure. After the repair is complete, check for DTCs, and clear them as needed.
- Turn the ignition to OFF.

Without an i-HDS:

- Remove the PGM-FI main relay 2 from the auxiliary under-hood fuse/relay box.

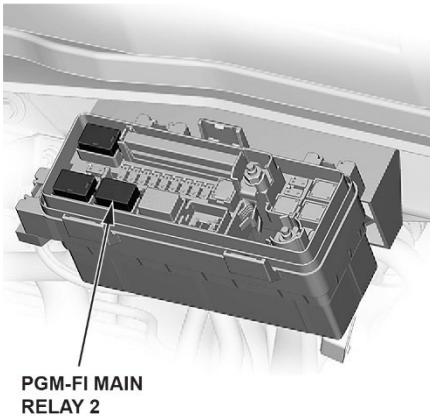

- Start the engine and let it idle until it stalls.
- Turn the ignition to OFF.
- Install the PGM-FI main relay 2.

3. Remove the front bulkhead cover.

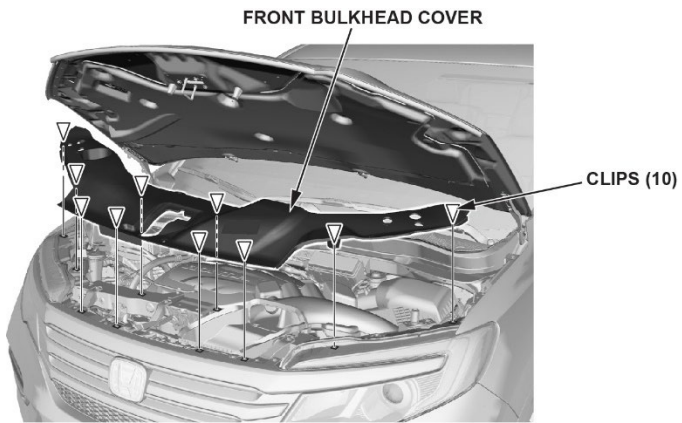

4. Remove the air intake tube.

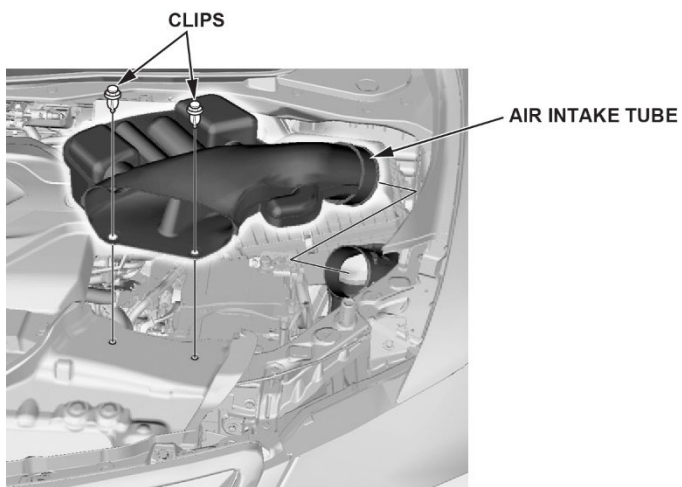

5. Disconnect both 12-volt battery terminals.

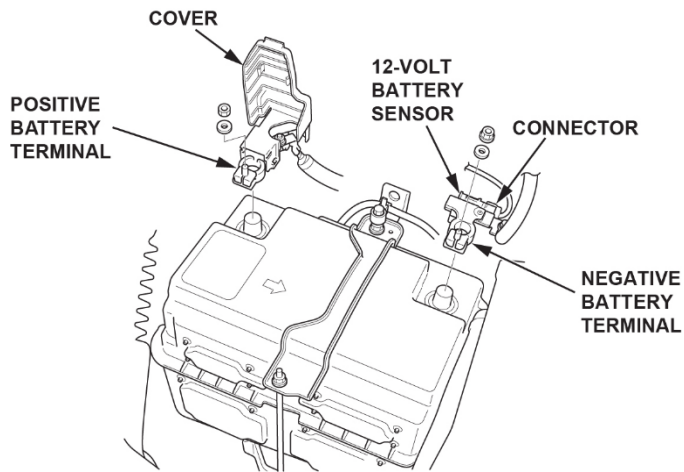

NOTICE

To protect the terminal connector from damage, do not hold it when removing the negative terminal.

NOTE:

- Always disconnect the negative terminal first.
- Do not disconnect the 12-volt battery sensor from the cable.

6. Remove the left side second row seat.

- *Second Row Seat Removal and Installation (Bench)* ([Click Here](#))
- *Second Row Seat Removal and Installation (Captain)* ([Click Here](#))

7. Remove the fuel tank unit access panel and disconnect the fuel tank unit connector.

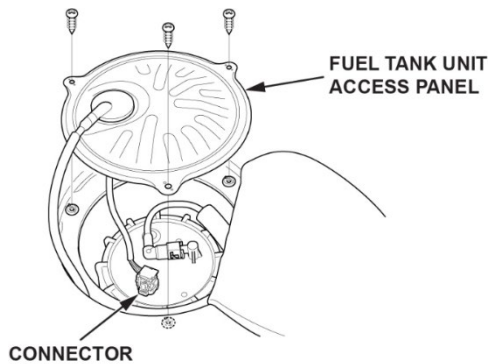

8. Place a rag or shop towel over the quick-connect fitting.

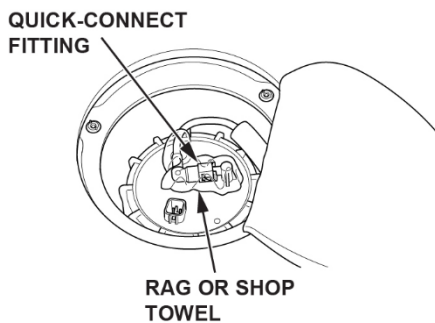

9. Disconnect the quick-connect fitting from the fuel tank unit.

10. Remove the fuel tank unit locknut using the fuel sender wrench (T/N 070AA-T0AA100) as shown.

NOTE:

- Keep the fuel sender wrench from floating.
- After unlocking the fuel tank unit cam lock ring, clean the top of the fuel pump flange and adjacent areas to make sure it is free of dirt, dust, and debris.

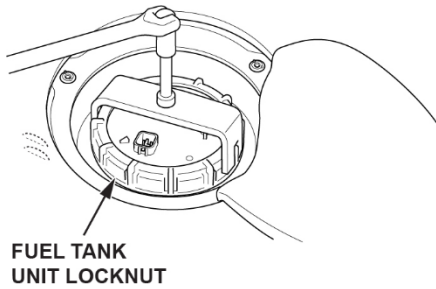

11. Remove the fuel tank unit locknut, then remove the fuel tank unit.

NOTICE

Do not bend or twist the fuel level sensor arm excessively. This may damage the fuel level sensor or cause it to send inaccurate readings.

NOTE:

- After removing the fuel pump unit, clean the fuel tank around the fuel pump opening.
- After removing the fuel pump O-ring, clean the fuel tank around the O-ring opening and make sure it is free of dirt, dust, and debris.

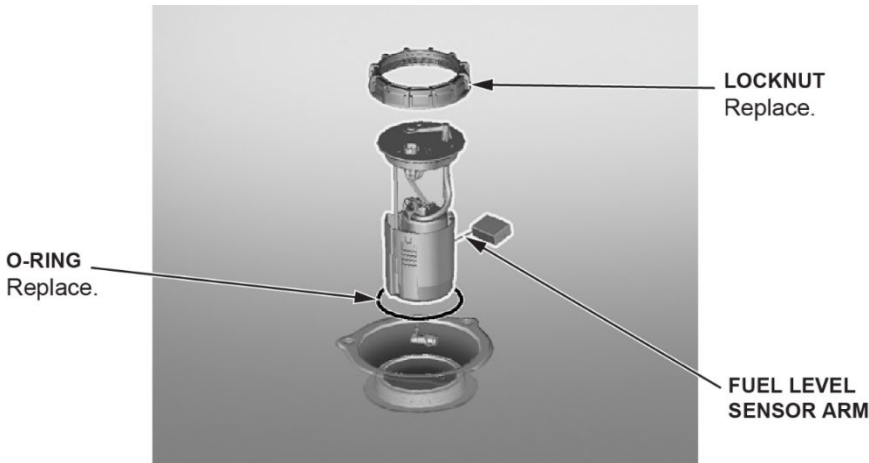

12. Prepare the fuel tank unit and parts to be replaced.

NOTE: Take a photo of the fuel tube and wire harness, and note their routing for assembly. There are various types of routing.

13. Spread the wire harness clamps, and remove the wire harness. Make sure not to damage the wire harness.

NOTICE

Do not spread the clamps too wide. Spreading them too wide may damage them.

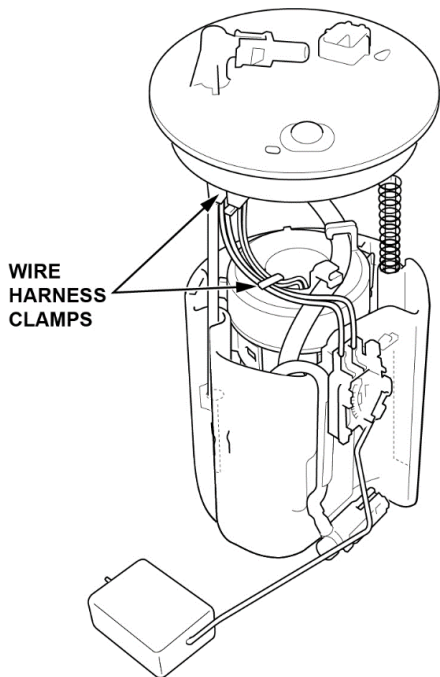

14. Press the tab on the fuel level sensor to release the lock. Then, push up on the fuel level sensor.

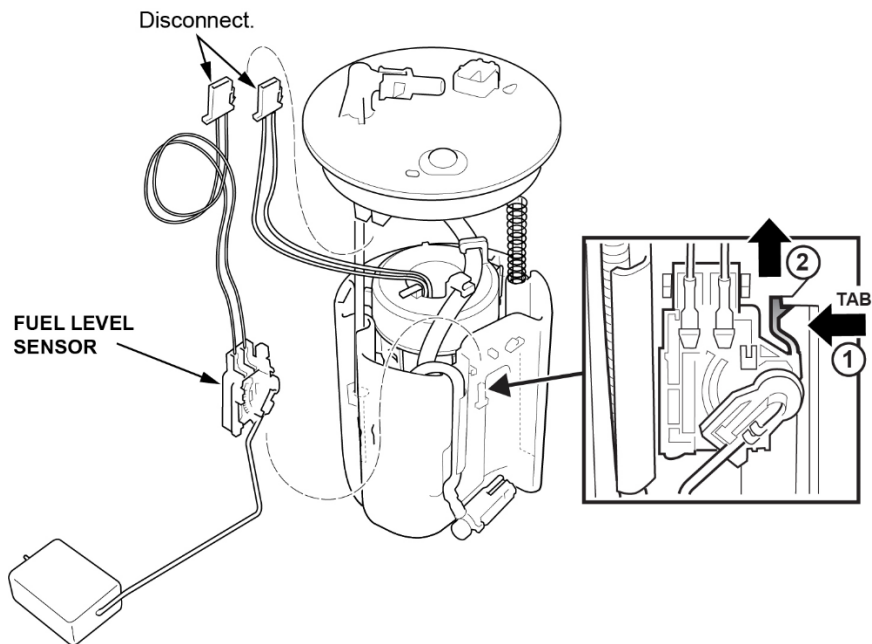

15. Remove the E-rings and discard them.

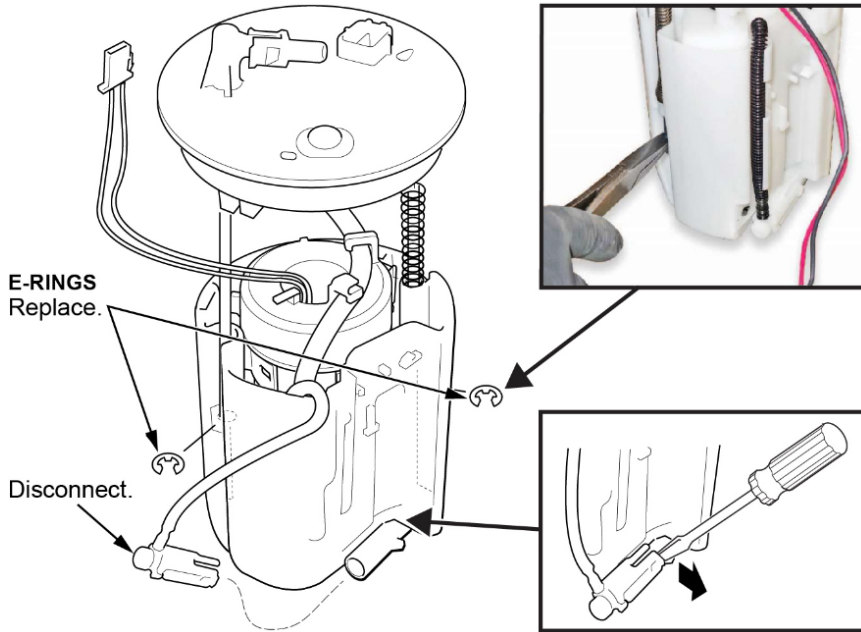

16. Disconnect the joint at the bottom of the reservoir.

17. Remove the fuel filter assembly from the reservoir by releasing the three clips.

NOTICE

Do not spread the clips too wide. Spreading them too wide may damage them.

NOTE: The spring may slide off the sliding shaft. Retain this spring. It will be used during assembly.

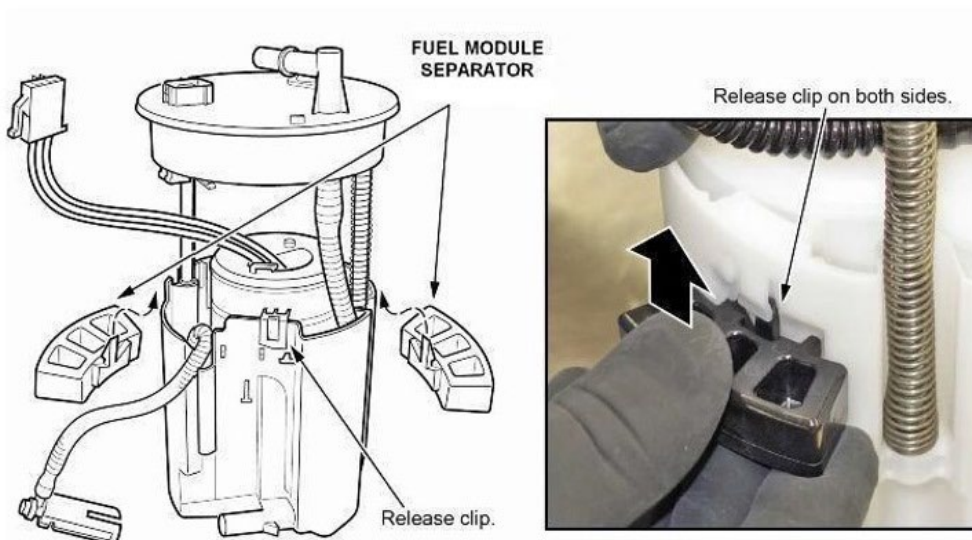

18. Release the three clips at the base of the fuel pump assembly and remove it from the fuel filter.

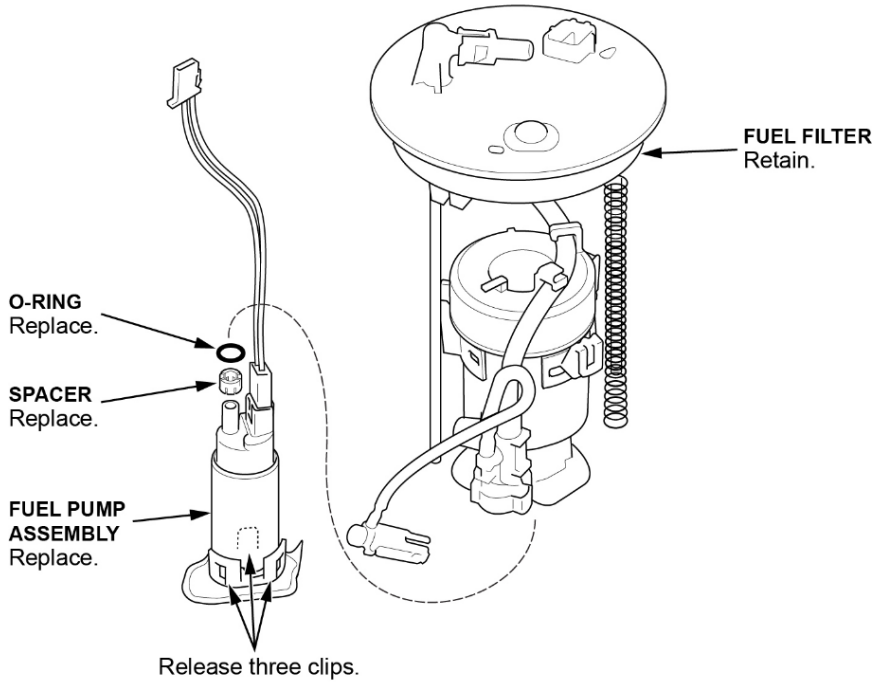

19. Pull the fuel pump assembly out of the fuel filter.

NOTE: If the O-ring remains on the fuel filter, use a flat-tip screwdriver wrapped in protective tape to remove it. Make sure not to damage the O-ring seat section.

20. Install the new spacer onto the new fuel pump motor.

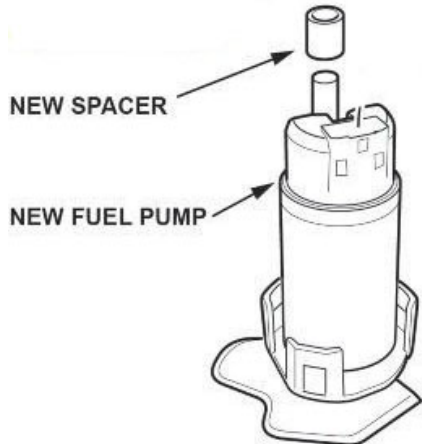

21. Install the new O-ring, then lubricate ONLY the outside edge of it, using clean engine oil.

NOTE: Do not pinch the O-ring during installation.

NEW O-RING

Lubricate after installing.
Do not lubricate the
inside of the o-ring.

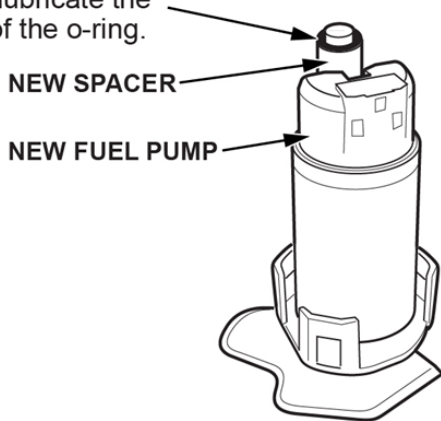

22. Install the new harness making sure the connection is secure and the connectors are firmly locked into place.

NEW O-RING

Lubricate after installing.
Do not lubricate the
inside of the o-ring.

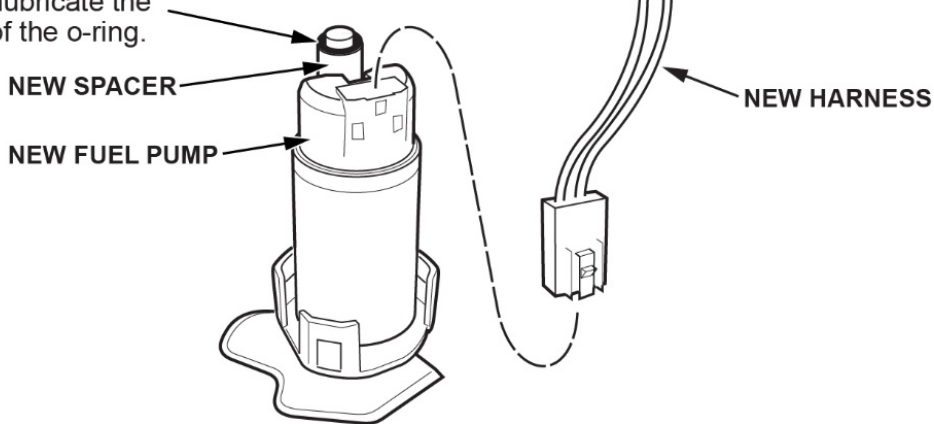

23. With the palm of your hands press the fuel pump into the suction fuel filter.

Click here to view video:



NOTICE

When pressing the fuel pump into the suction filter make sure you do so with a single firm push. Failure to do so may damage the O-ring. If it is seated properly, you will hear a click.

If you do not hear the click, remove all parts and inspect the O-ring for damage. If the O-ring is damaged, it must be replaced. Reassemble using the above process.

NOTE:

- When inserting the pump, be careful not to break the suction filter.
- If the O-ring is damaged; replace it with a new one.
- After installing the fuel pump to the suction filter, make sure the clips are firmly attached to the new fuel pump.

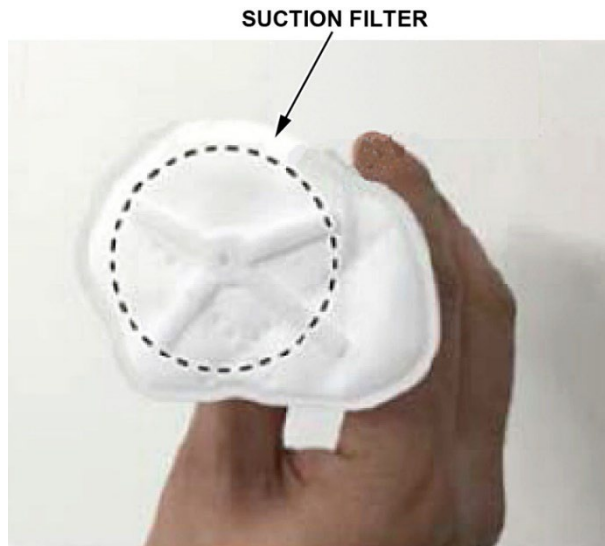

GOOD



NO GOOD

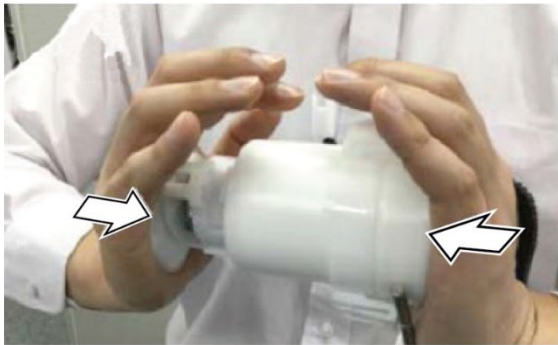

24. Install the fuel filter assembly to the reservoir.

NOTE:

- Insert the spring into the sliding shaft, and make sure it is lined up when installing the fuel filter.
- Make sure the fuel tube is routed **exactly** as shown in the photo taken before disassembly.
- Make sure the three clips are fully engaged.

25. Install the new E-rings.

NOTE: After installation, make sure the E-rings can be rotated with your finger. If they cannot be rotated, the E-rings may not be fully seated or may be incorrectly installed.

26. Install the fuel level sensor to the reservoir. Make sure the lock is engaged and the connection is secure.

NOTICE

Do not bend or twist the fuel level sensor arm excessively. This may damage the fuel level sensor or cause it to send inaccurate readings.

27. Install the wiring harness to the clamps.

NOTICE

Do not spread the clamps too wide. Spreading them too wide may damage them.

NOTE:

- Clip in the smaller harness wires followed by the larger wires.
- Make sure not to damage the wire harness.
- Make sure to route the wire harness **exactly** as shown in the photo taken before disassembly.

HARNESS ROUTING:

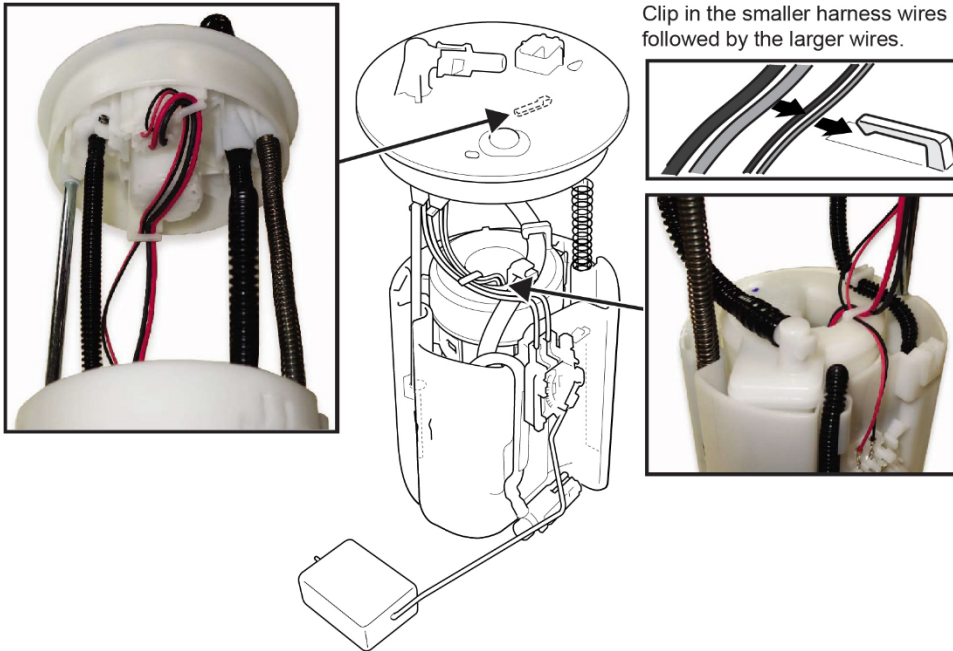

28. While compressing the fuel tank unit, make sure the movement is smooth and the fuel tube and wiring harness do not stretch, pinch, or bind.

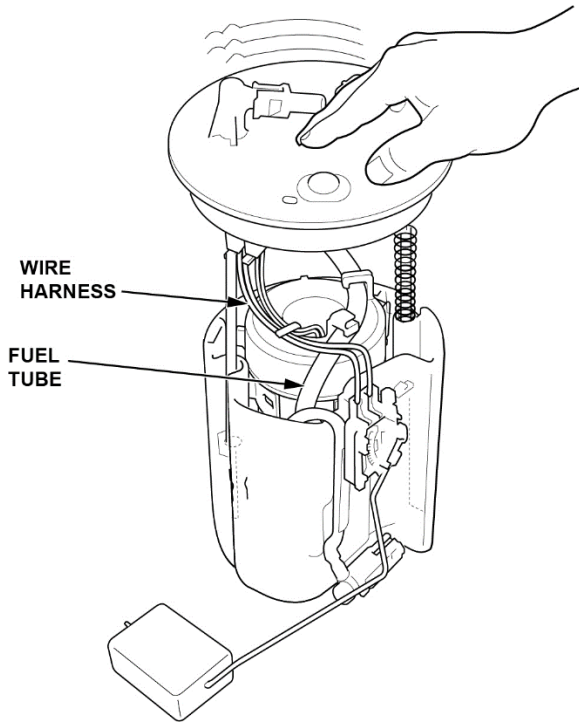

29. Insert the fuel tank unit partially into the fuel tank with a new O-ring.

NOTICE

Do not bend or twist the fuel level sensor arm excessively. This may damage the fuel level sensor or cause it to send inaccurate readings.

NOTE:

- Be careful not to damage the O-ring.
- Do not coat the O-ring with any oil.

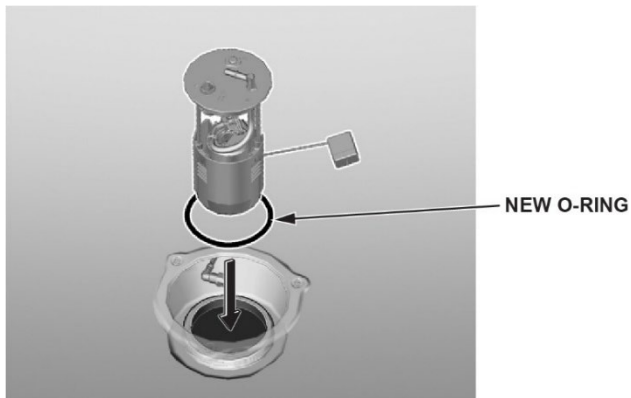

30. Line up the mark on the fuel tank unit to the marks on the fuel tank, then insert the fuel tank unit into the fuel tank.

NOTE: To avoid any leaks, check the O-ring, either visually or by hand, to make sure it is not pinched.

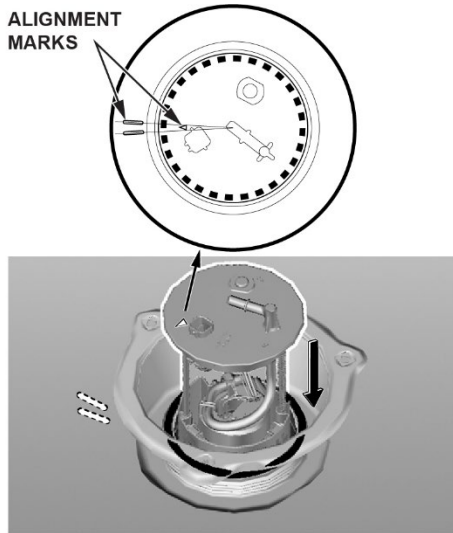

31. Line up the mark on the new locknut to the start of the thread on the fuel tank.

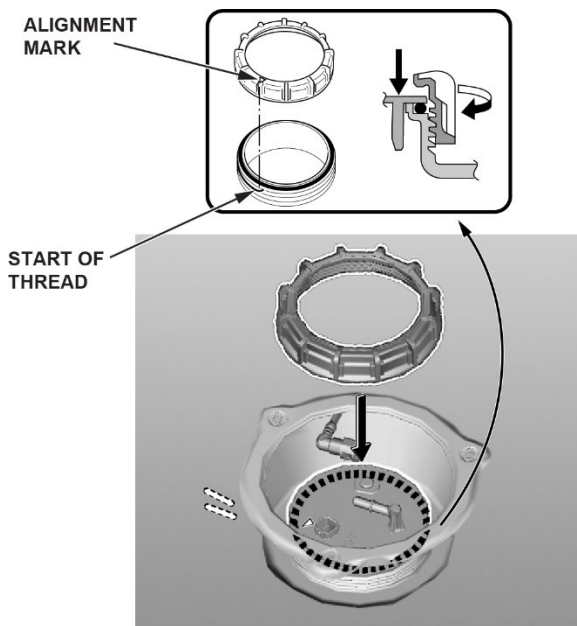

32. Press down on the fuel tank unit while turning the locknut clockwise by hand.

33. Using the fuel nut wrench, tighten the locknut to **100 N·m (74 lb-ft)**.

NOTE:

- During installation, check the O-ring, either visually or by hand, to make sure it is not pinched.
- After tightening, make sure the mark on the fuel tank unit is still lined up with the marks on the fuel tank.

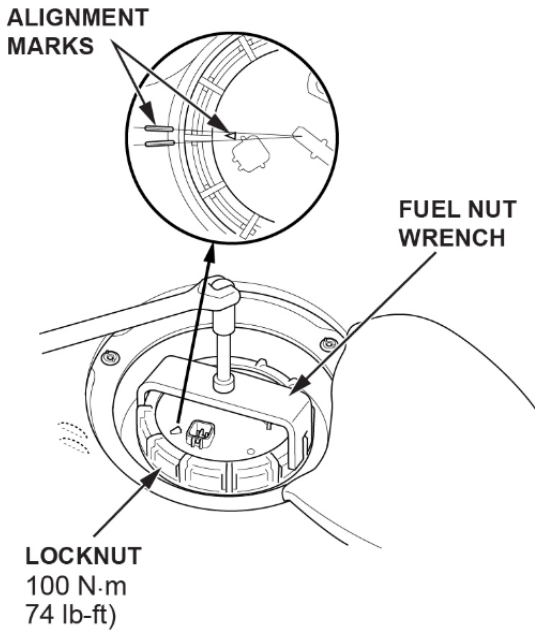

34. *If the marks do not line up*, friction between the fuel tank unit and the locknut may cause the fuel tank unit to turn while tightening. Observe the difference (shaded area), and loosen the locknut until the fuel tank unit can be rotated. Rotate the fuel tank unit **counter-clockwise** by the same amount, and repeat the tightening process.

NOTE: Repeat this step as necessary until the marks are lined up when the locknut is tightened to the specified torque.

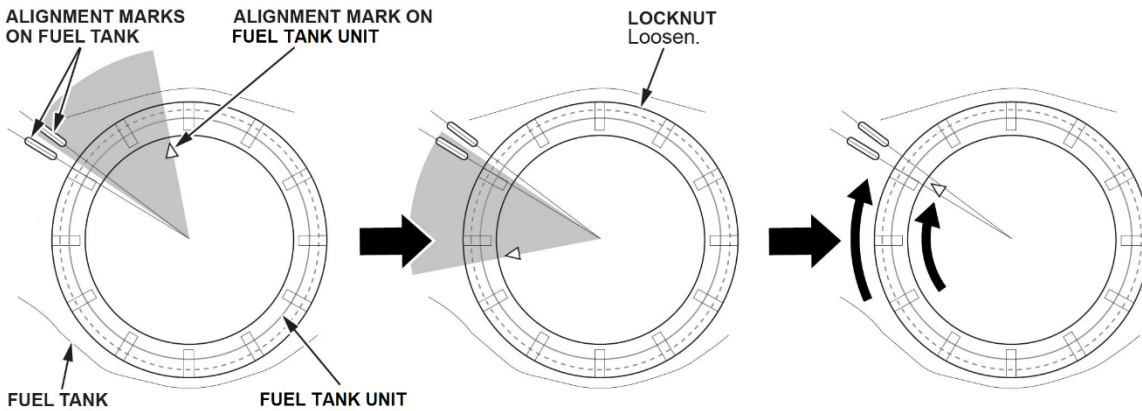

35. Remove the quick-connect fitting retainer from the fuel tank unit, then install a new retainer onto the quick-connect fitting.

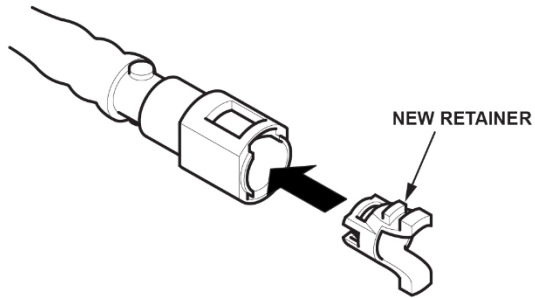

36. Connect the fuel line quick-connect fitting.

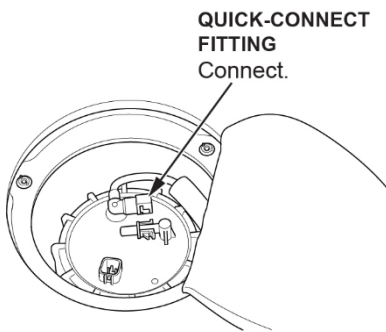

37. Connect the fuel tank unit connector.

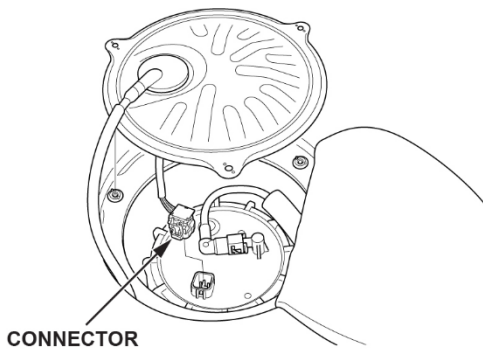

38. Connect the 12-volt battery terminals and torque to **4.0–6.0 N·m (3.0–4.4 lb-ft)**.
39. Turn the ignition to ON, but do not turn the engine on. After the fuel pump runs for about **2 seconds**, the fuel line will be pressurized. Repeat two or three times, then make sure there is no fuel leakage.

40. Install the fuel tank unit access panel.

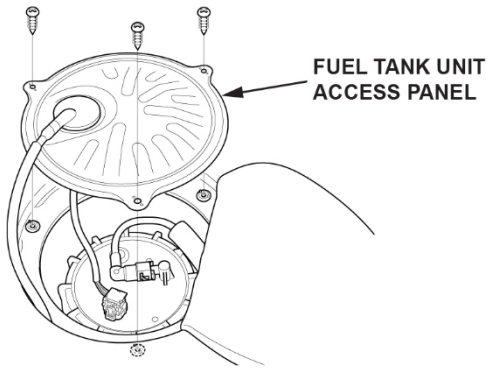

41. Install the remaining parts in the reverse order of removal.

42. Clear all DTCs using an i-HDS.

43. *California residents only:* Fill out a Vehicle Emissions Recall – Proof of Correction certificate, and use **XGL** as the recall number. Have the service advisor give the certificate to your customer, and advise him or her to keep it as proof that the recall was completed. Your customer will need to submit this certificate to the DMV only if the DMV requests it. If you need more certificates, use reorder number **Y0657**.

Vehicle Emission Recall - Proof of Correction				
License Number	Make	Year Model	Body Type	Vehicle Identification Number
				<input type="text"/>
Manufacturer _____			Recall Number XGL	
The above described vehicle has been repaired, modified and/or equipped with new emission control devices to meet applicable California Emission Control Laws.				
Dealer's Name _____		Address, City, State and Zip _____		
Date _____	Dealership's Authorized Signature _____			
Return this certificate to DMV only when required - otherwise retain for your records.				

Y0657 ACL 24832 (0212)