

April 16, 2024

Version 2

## Safety Recall: 2018–19 RLX Fuel Pump Motor

Supersedes 24-019, dated May 31, 2024 to revise the information highlighted in **yellow**.

### AFFECTED VEHICLES

Year	Model	Trim Level	VIN Range
2018–19	RLX (except Sport Hybrid)	ALL	Check the iN-VIN status for eligibility.

### REVISION SUMMARY

**Under PARTS INFORMATION, information was clarified.**

### BACKGROUND

On December 18, 2023, American Honda notified NHTSA of its intention to initiate a STOP SALE and safety recall for a certain number of 2018–19 RLX (except Sport Hybrid) units to replace the fuel pump motor manufactured with defective impellers.

Due to swelling of the fuel pump motor impeller, the fuel pump may seize and stop working. A defective impeller may cause the fuel pump to become inoperative, which could prevent an engine from functioning as intended. This limitation may cause a loss of motive power or a stall while being driven, increasing the risk of a crash or injury, creating a safety hazard.

If this bulletin appears during an iN-VIN status inquiry, the vehicle is subject to a safety recall. Any affected vehicles in your dealer inventory are on STOP SALE until further notice. Refrain from calling Tech Line for updates.

### CLIENT NOTIFICATION

Owners of the affected vehicles will be sent a notification of this campaign. They will be informed that due to a limited supply of parts (at this time) Acura is prioritizing the repair of client vehicles experiencing symptoms related to this recall.

When **adequate replacement parts** become available, Acura will send a follow-up letter to clients instructing them to schedule an appointment for all vehicles affected by this recall. If a client experiences the known symptoms associated with this **safety recall** (see CORRECTIVE ACTION), they are instructed to contact their local Acura dealer for the repair. For any questions or concerns clients may have, you may have them contact American Honda Customer Support & Campaign Center at **1-888-234-2138**.

The following suggested text should be included on any repair order for an already sold affected vehicle that comes in for service. This information should be printed out completely any time service is conducted on an affected vehicle, and the recall repair has not yet been completed. Depending on parts availability, the normal procedures under DOM 7.2.1 will apply for this recall.

#### Suggested Verbiage to be Included on the Repair Order

*Client was advised that:*

*The vehicle is subject to a recall affecting the fuel pump motor. The parts necessary to complete the recall repair are currently limited. Vehicles with eligible VINs and the following symptoms: difficulty starting, engine hesitation while driving, and/or an illuminated check engine light displayed with DTC P0087, are eligible for immediate repair. Once parts repair kits are available, if the vehicle has not been repaired, the registered owner of the vehicle will receive a notice to bring the vehicle in for a replacement of the components, regardless of symptom.*

**CLIENT INFORMATION:** The information in this bulletin is intended for use only by skilled technicians who have the proper tools, equipment, and training to correctly and safely maintain your vehicle. These procedures should not be attempted by “do-it-yourselfers,” and you should not assume this bulletin applies to your vehicle, or that your vehicle has the condition described. To determine whether this information applies, contact an authorized Acura automobile dealer.

## IMPORTANT NOTICE

Vehicles that are both shown as an eligible VIN and experiencing any of the following symptoms will be prioritized for repair: difficulty starting, engine hesitation while driving, and/or an illuminated check engine light displayed with DTC P0087 (Fuel Rail Pressure Too Low) stored.

## CORRECTIVE ACTION

Do an iN-VIN status inquiry to make sure the vehicle is shown as eligible. If the allocated parts are available, follow the REPAIR PROCEDURE to replace the fuel pump motor. A limited number of parts have been allocated and will continue to be allocated based on availability at this time. If parts are not available, the STOP SALE remains in effect for that vehicle. To see if a vehicle in inventory is affected by this safety recall, do a VIN status inquiry before selling it. Some vehicles affected by this campaign may be in your new or used vehicle inventory.

## PARTS INFORMATION

### NOTE:

- Refer to the Parts Information Bulletin B24-0013, *Multi-Model Fuel Pump Motor Safety Recall Parts Availability*, for details regarding parts availability and ordering.
- Prioritize repairing client vehicles that meet both the VIN status eligibility **and** exhibit a known symptom such as: difficulty starting, engine hesitation while driving, and/or an illuminated check engine light with DTC P0087 (Fuel Rail Pressure Too Low).

Part Name	Part Number	Quantity
Fuel Pump Motor Kit	06170-TY2-306	1

## TOOL INFORMATION

Tool Name	Tool Number	Quantity
Denso Fuel Module Separator Set	07AAF-T5RA100	1
Fuel Sender Wrench	07AAA-S0XA100	1

## WARRANTY CLAIM INFORMATION

Operation Number	Description	Flat Rate Time	Defect Code	Symptom Code	Template ID	Failed Part Number
3101EH	Replace the fuel pump motor.	1.1 hr	6FE00	GHZ00	B24019A	17045-TY2-A00

Skill Level: Repair Technician

## REPAIR PROCEDURE

### ⚠ WARNING

Fuel pump motor removal exposes fuel, which can ignite, causing a fire or explosion.

This can cause serious injury or death.

Always work in a well-ventilated area and keep sparks or open flames away.

1. Remove the emergency fuel funnel from the case, then insert it into the fuel filler neck to relieve the pressure in the fuel tank.

NOTE: The emergency fuel funnel is in the trunk toolbox.

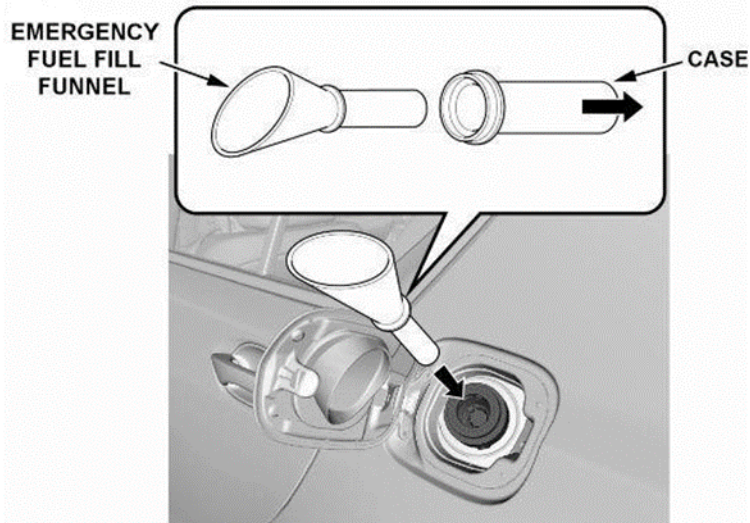

2. Remove PGM-FI main relay 2 from the driver's under-dash fuse/relay box.

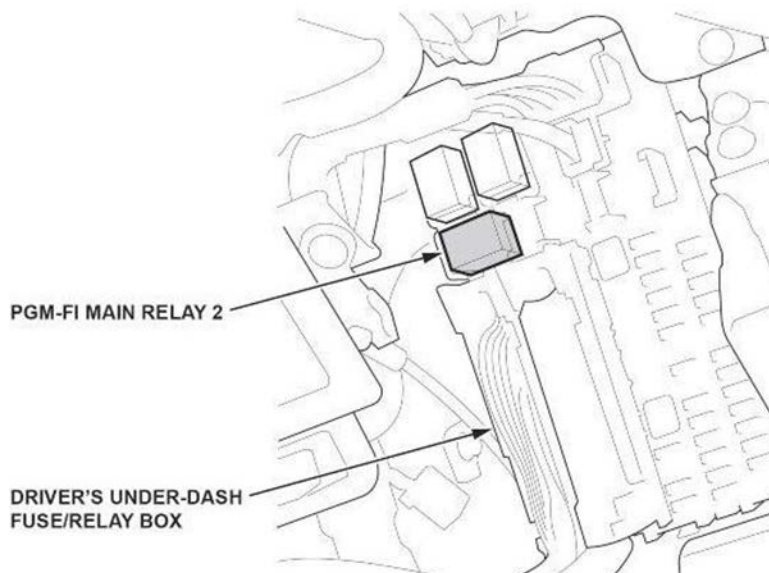

3. Start the engine and let it idle until it stalls.
4. Turn the ignition to OFF.
5. Install PGM-FI main relay 2.

6. Disconnect both 12-volt battery terminals.

**NOTICE**

- Always disconnect the negative terminal first.
- To protect the terminal connector from damage, do not hold it when removing the terminal.
- Do not disconnect the 12-volt battery sensor from the cable.

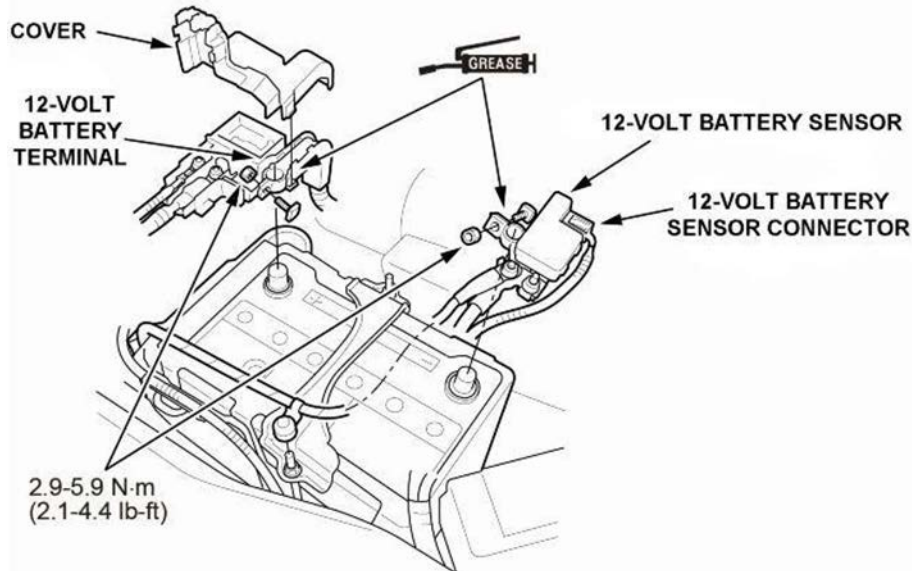

7. Remove the bolt between the rear seat-back and the rear seat cushion.

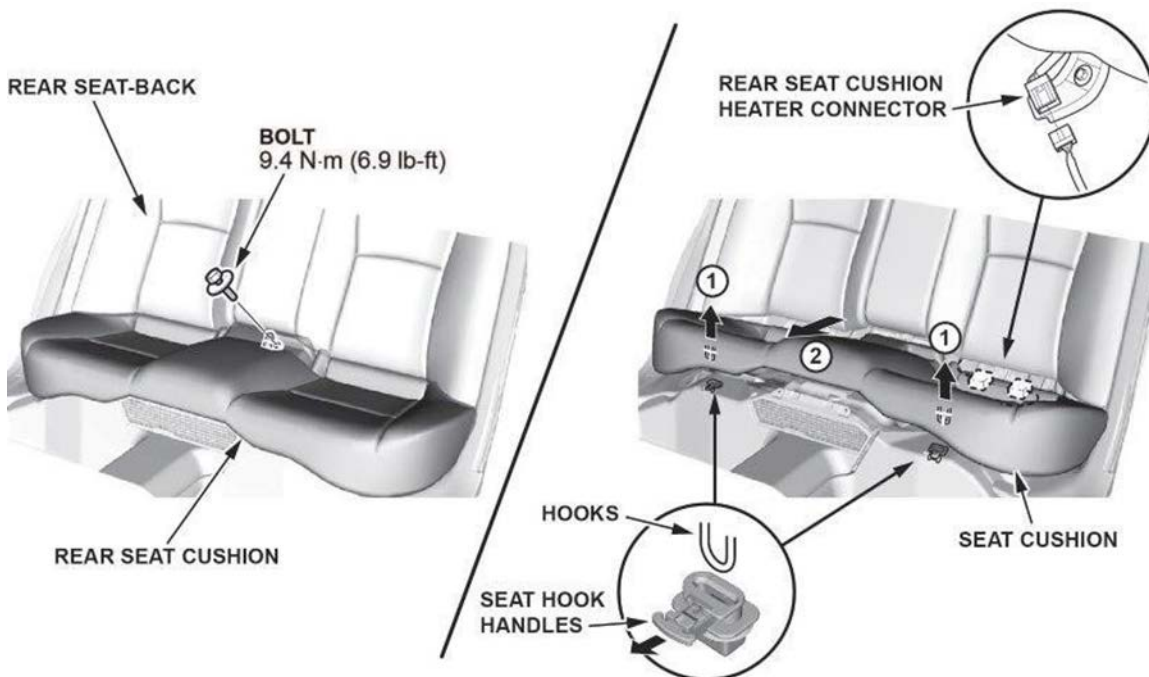

- While pushing down on the seat cushion, pull the seat hook handles to release the hooks.
- *With rear seat cushion heater:* Disconnect the rear seat cushion heater connector.
- Remove the rear seat cushion.

8. Remove the fuel tank unit access panel and disconnect the fuel tank unit connector.

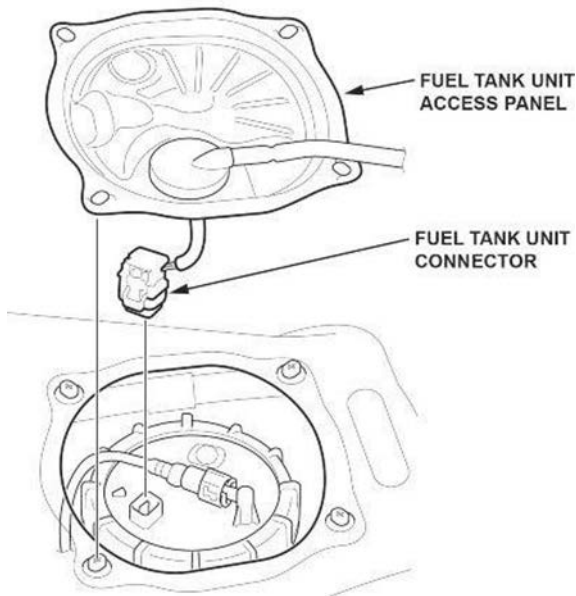

9. Place a rag or shop towel over the quick-connect fitting, and disconnect it

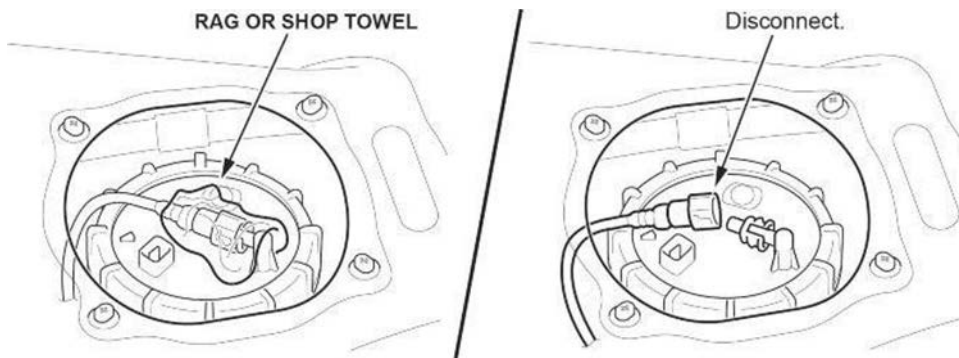

10. Unlock the fuel tank unit locknut using the fuel sender wrench (T/N 07AAA-S0XA100).

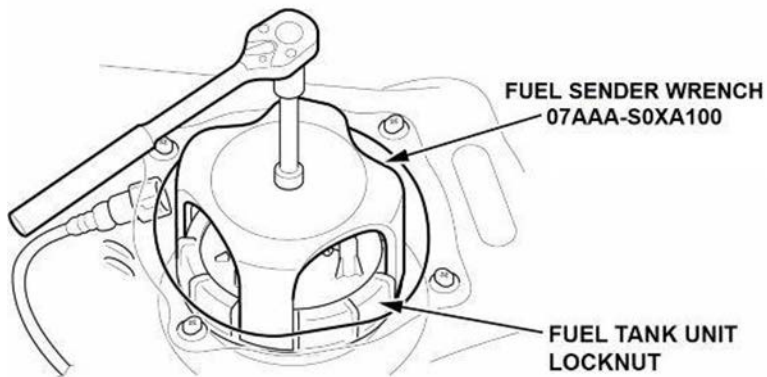

11. Remove the fuel tank unit locknut and remove the fuel tank unit.

NOTE:

- After unlocking the fuel tank unit cam lock ring, clean the top of the fuel pump flange and adjacent areas to make sure it's free of dirt, dust, and debris.
- Make sure not to bend or twist the fuel level sensor arm excessively.

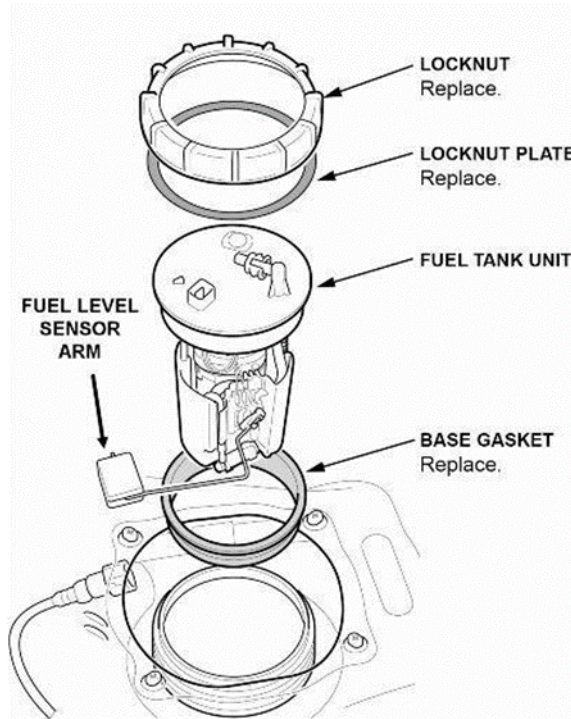

12. Disassemble the fuel tank unit.

- Prepare the fuel tank unit and parts to be replaced.  
NOTE: Take a photo of the fuel tube and wire harness and note their routing for assembly. There are various types of routing.
- Spread the wire harness clamps and remove the wire harness. Make sure not to damage the wire harness.

NOTICE

Do not spread the clamps too wide. Spreading them too wide may damage them.

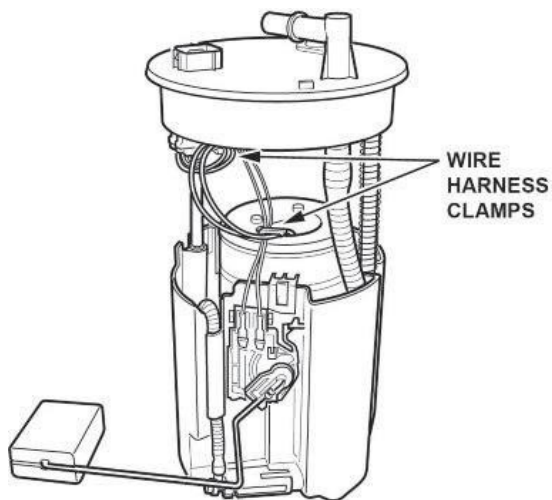

- Remove the fuel level sensor.
- Disconnect the harnesses.

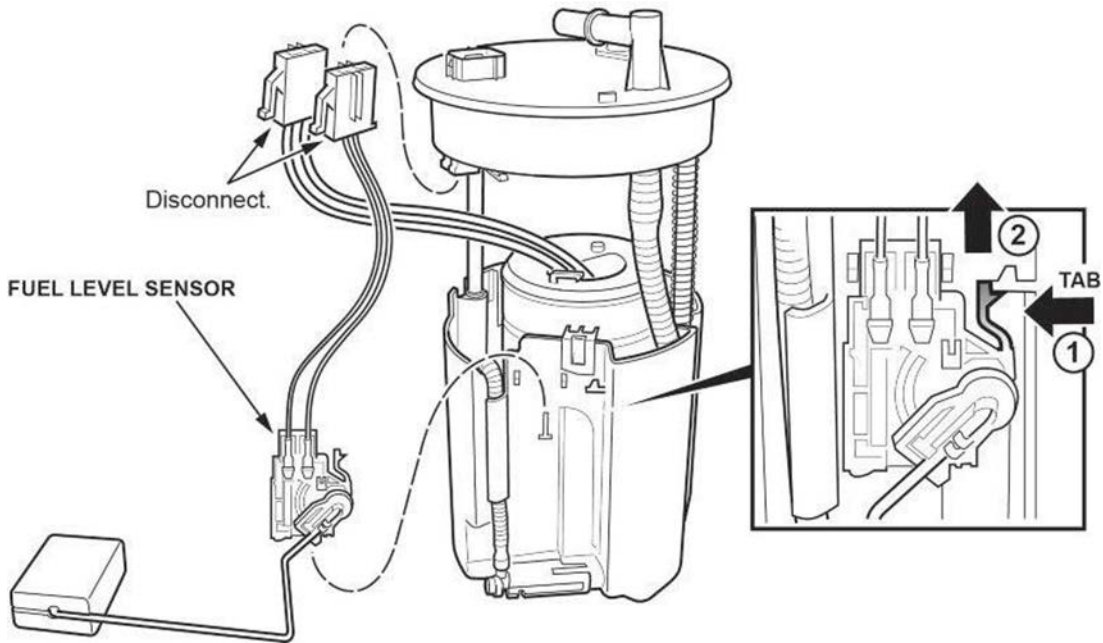

- Press the tab to release the lock (1). Then, push up on the fuel gauge sending unit (2).
- Remove the fuel level sensor from the fuel tank unit.
- Remove the E-rings, and throw them away. Do not use them again.

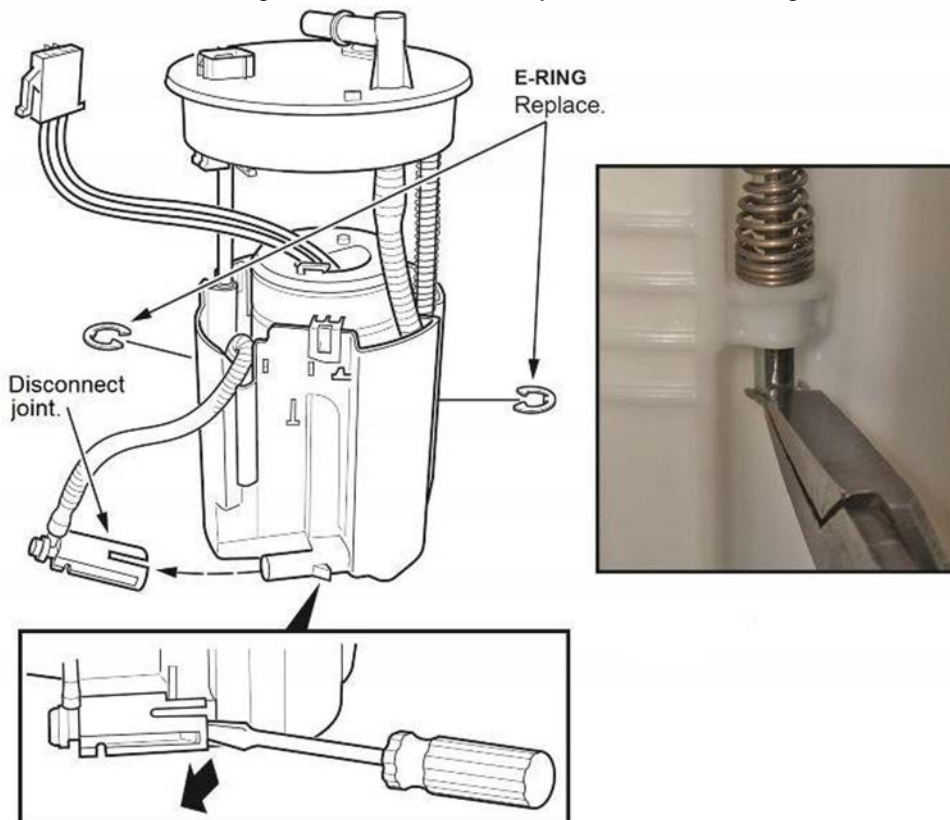

- Disconnect the joint at the bottom of the reservoir.
- Remove the fuel filter assembly from the reservoir by releasing the three clips.

**NOTE:**

- Use the clip release tools on two of the clips.
- The spring may slide off the sliding shaft. Retain this spring. It will be used during assembly.

**NOTICE**

- Do not spread the clips too wide. Spreading them too wide may damage them.

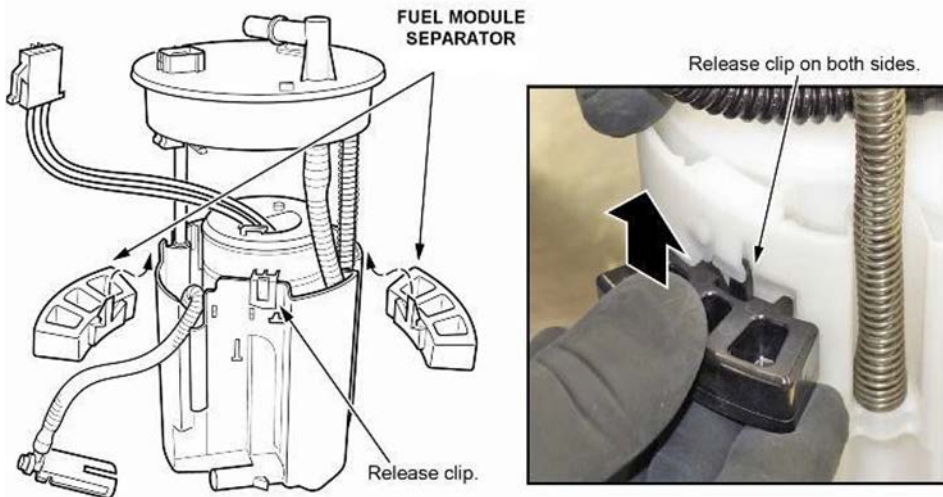

- Remove the fuel pump assembly from the fuel filter.
- Release the three clips at the base of the fuel pump assembly.
- Pull the fuel pump assembly out of the fuel filter.

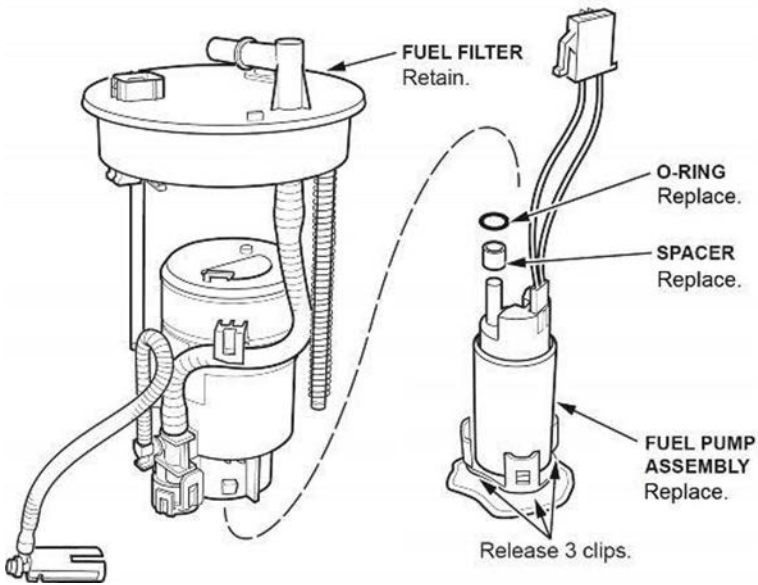

13. Install the new spacer onto the new fuel pump motor.

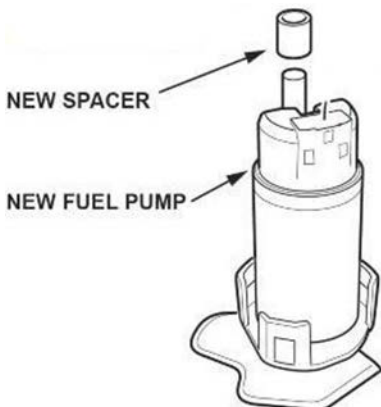



14. Install the new O-ring, then lubricate ONLY the outside edge of it, using clean engine oil.

NOTE: Do not pinch the O-ring during installation.

**NEW O-RING**

Lubricate after installing.

Do not lubricate the inside of the o-ring.

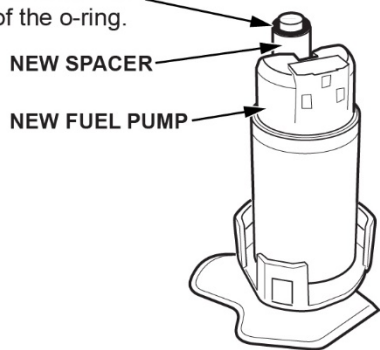

15. Install the new harness and make sure the connection is secure and the connectors are firmly locked into place.

**NEW O-RING**

Lubricate after installing.

Do not lubricate the inside of the o-ring.

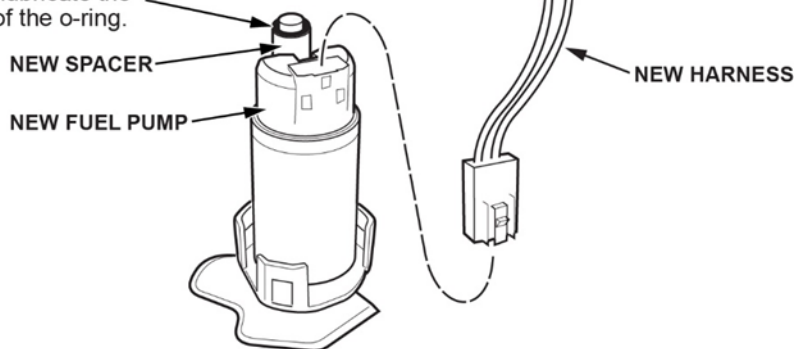

16. With the palm of your hands press the fuel pump into the suction fuel filter.

[▶ PLAY VIDEO](#)

Click here to view the video:

**NOTICE**

When pressing the fuel pump into the suction filter, make sure you do so with a single firm push. Failure to do so may damage the O-ring. If it is seated properly, you will hear a click.

If you do not hear the click, remove all parts and inspect the O-ring for damage. If the O-ring is damaged, it must be replaced. Reassemble using the above process.

**NOTE:**

- When inserting the pump, be careful not to break the suction filter.
- If the O-ring is damaged, replace it with a new one.
- After installing the fuel pump to the suction filter, make sure the clips are firmly attached to the new fuel pump.

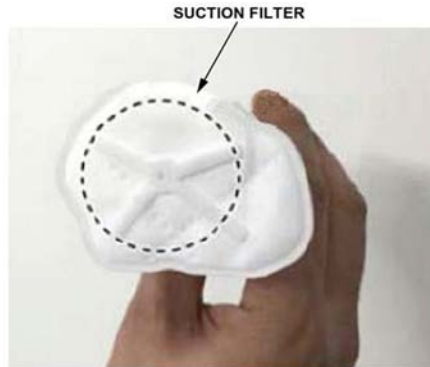

**GOOD**



**NO GOOD**



17. Install the fuel filter assembly to the reservoir.

NOTE:

- Insert the spring into the sliding shaft, and make sure it is lined up when installing the fuel filter.
- Make sure the fuel tube is routed **exactly** as shown in the photo taken before disassembly.
- Make sure the three clips are fully engaged.

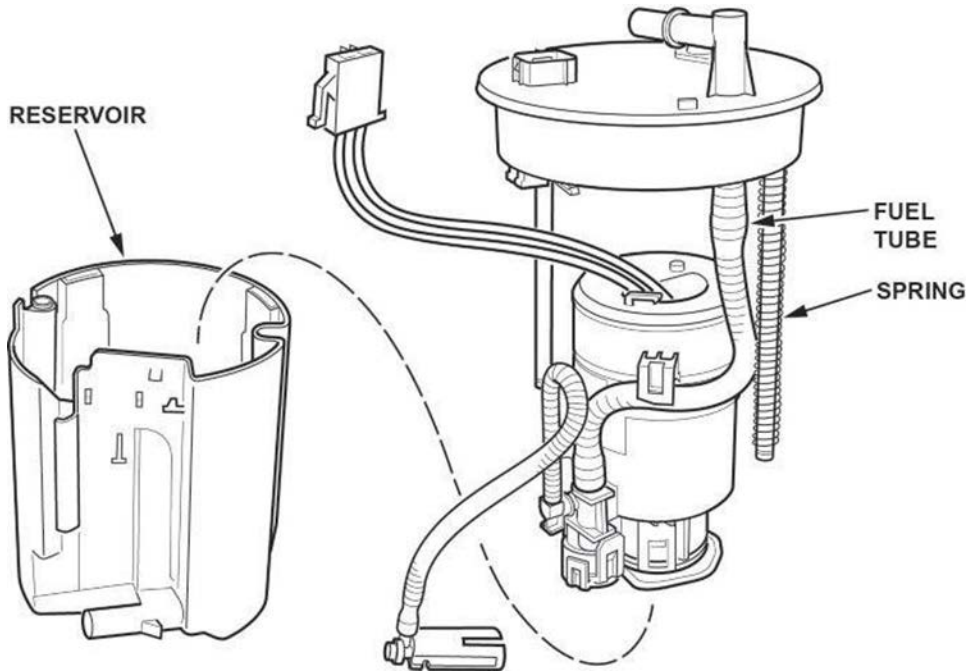

18. Install the new E-rings.

NOTE: After installation, make sure the E-rings can be rotated with your finger. If they cannot be rotated, the E-rings may not be fully seated or may be incorrectly installed.

19. Install the fuel level sensor to the reservoir. Make sure the lock is engaged.

NOTE: When installing the fuel level sensor, make sure the connection is secure and the connector is firmly locked into place. Be careful not to bend or twist it excessively.

20. Install the wiring harness to the clamps.

NOTE:

- Clip in the smaller harness wires followed by the larger wires.
- Make sure not to damage the wire harness.
- Make sure the wire harness is routed **exactly** as shown in the photo taken before disassembly.
- Do not spread the clamps too wide. Spreading them too wide may damage them.

**HARNESS ROUTING:**

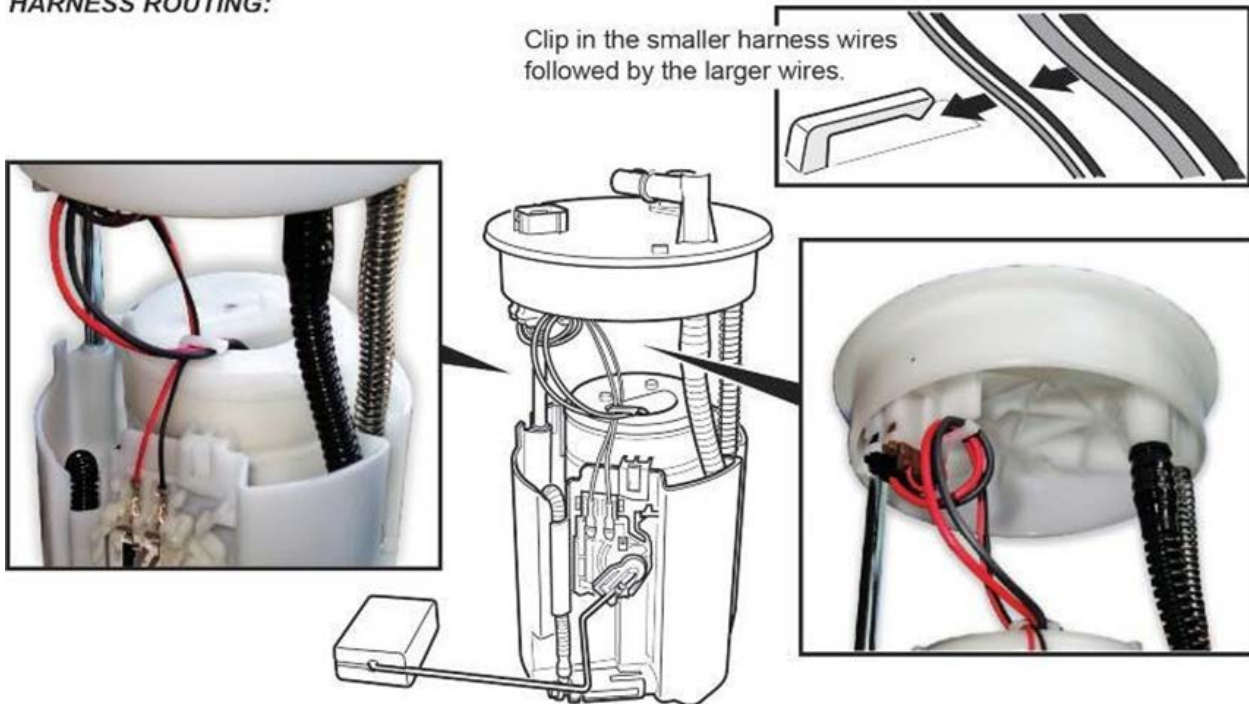

21. While compressing the fuel tank unit, make sure the movement is smooth and the fuel tube and wiring harness do not pinch or bind.

NOTE:

- Make sure the wire harness is not stretched.
- Make sure the fuel tube is not pinched.

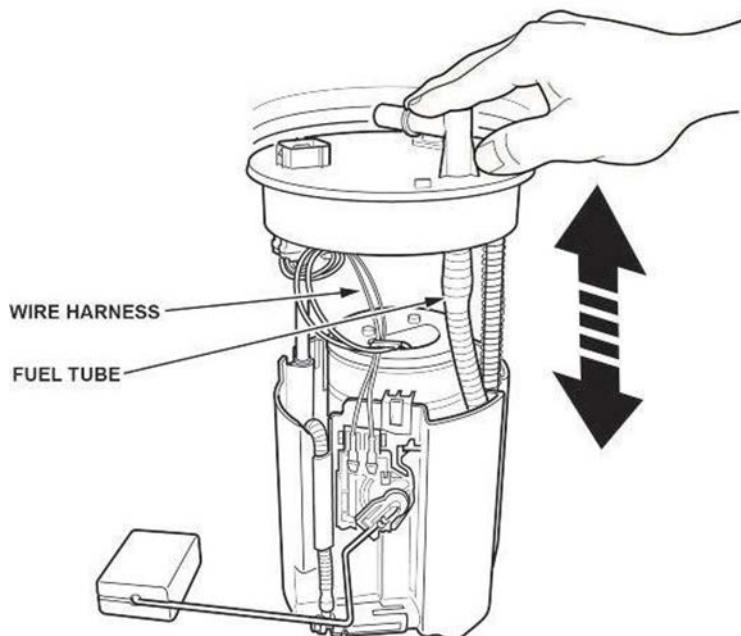

22. Partially insert the fuel tank unit into the fuel tank with a new base gasket.

NOTE:

- Before installing the new O-ring, clean the fuel tank around the fuel pump opening where the O-ring will seat. The tank opening must be free of dirt, dust, and debris.
- Be careful not to damage the new base gasket.
- Be careful not to bend the fuel gauge sending unit arm.
- Do not coat the base gasket with any oil.

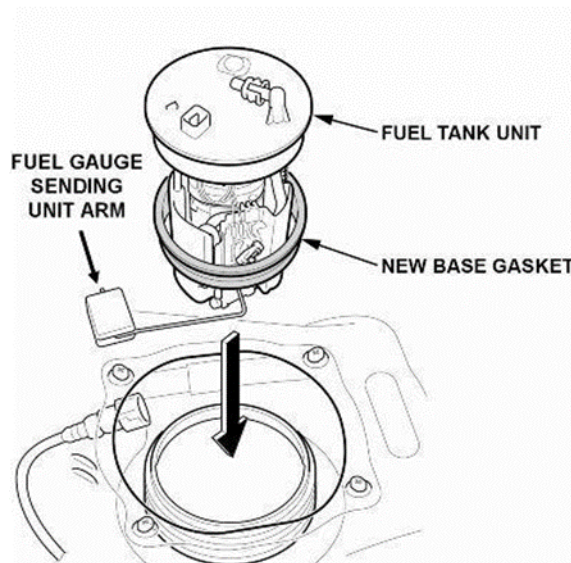

23. Line up the marks on the fuel tank and fuel tank unit, then insert the fuel tank unit into the fuel tank.

NOTE: To avoid a fuel leak, visually or by hand, make sure the base gasket is not pinched.

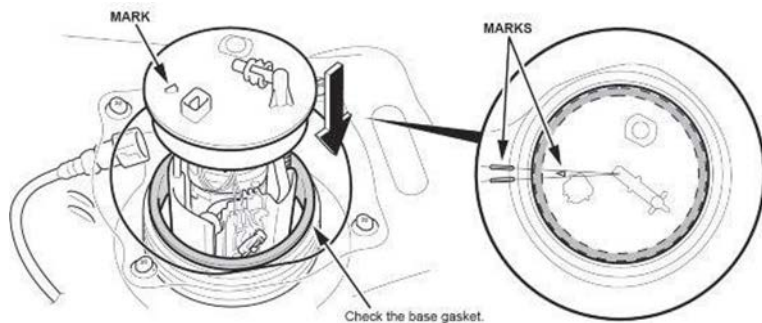

NOTICE

If the locknut is not properly installed, the fuel tank can be damaged and will require replacement.

24. Hold the fuel tank unit vertically and tighten a new fuel tank unit locknut with a new locknut plate by hand.

NOTE: Before tightening, line up the mark on the locknut to the start of the thread.

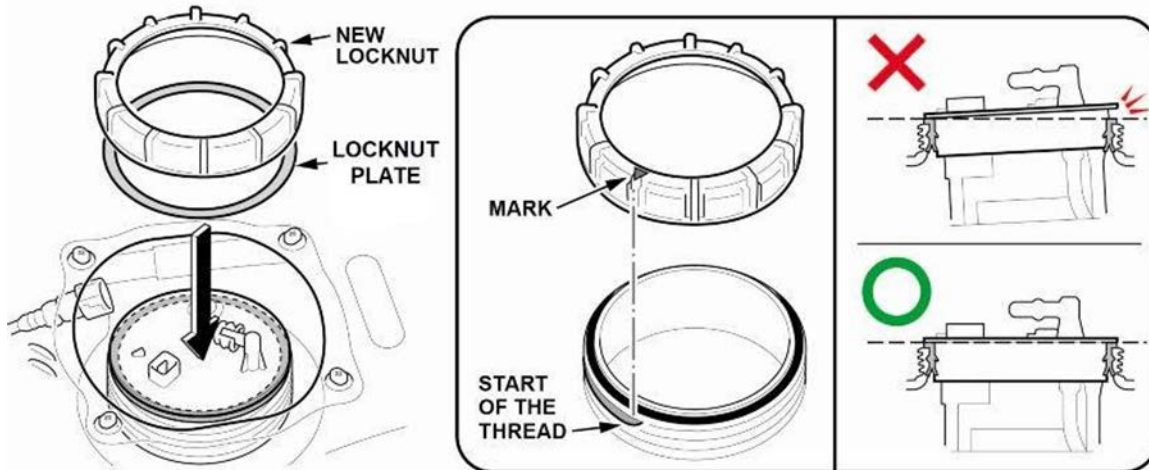

25. Tighten the fuel tank unit locknut to the specified torque using the fuel sender wrench.

NOTE:

- After tightening, make sure the marks are still lined up.
- Visually or by hand, make sure the base gasket is not pinched.

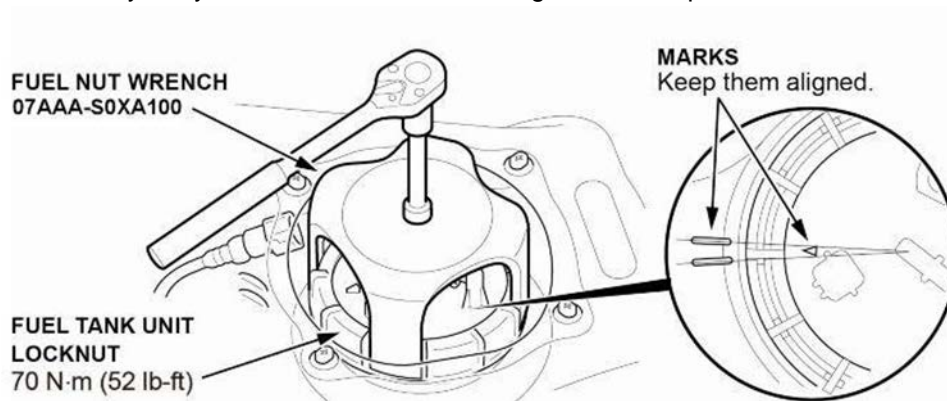

26. Install the new retainer to the quick-connect fitting.

27. Connect the fuel line quick-connect fitting and fuel tank unit connector.

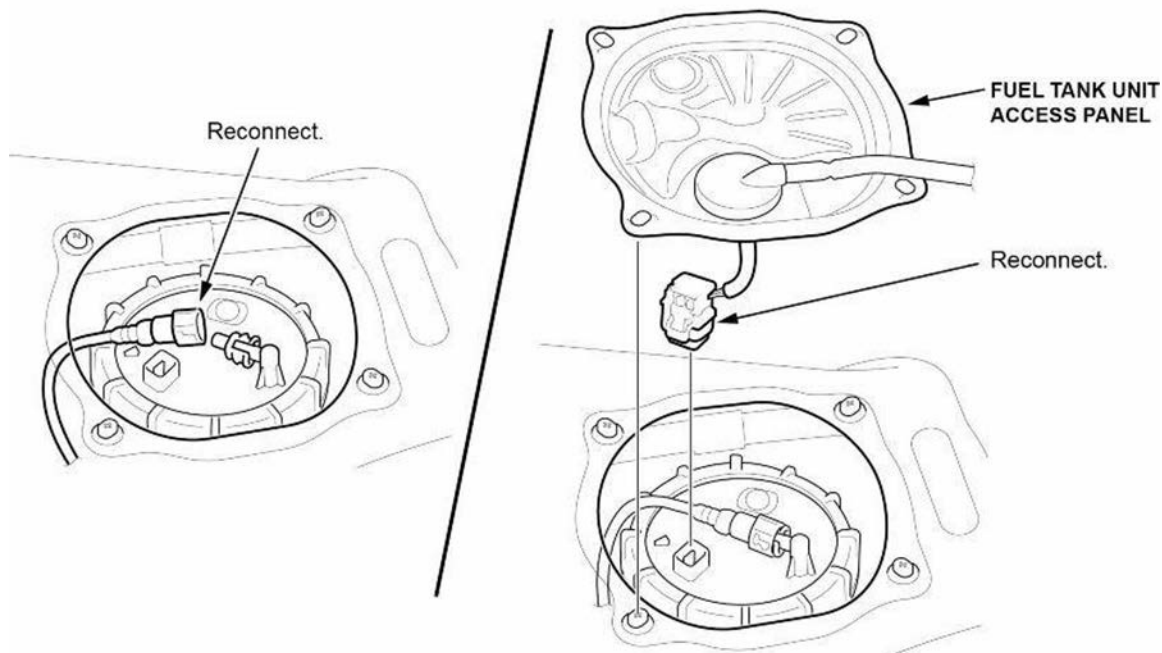

28. Connect the 12-volt battery terminals.

- Clean the battery terminals.
- Connect the positive cable and the battery terminal to the battery.

NOTE: Always connect the positive side first.

- Install the cover.
- Connect the negative cable and the battery sensor to the battery.

NOTE: To protect the battery sensor connector from damage, do not hold it when installing the negative terminal.

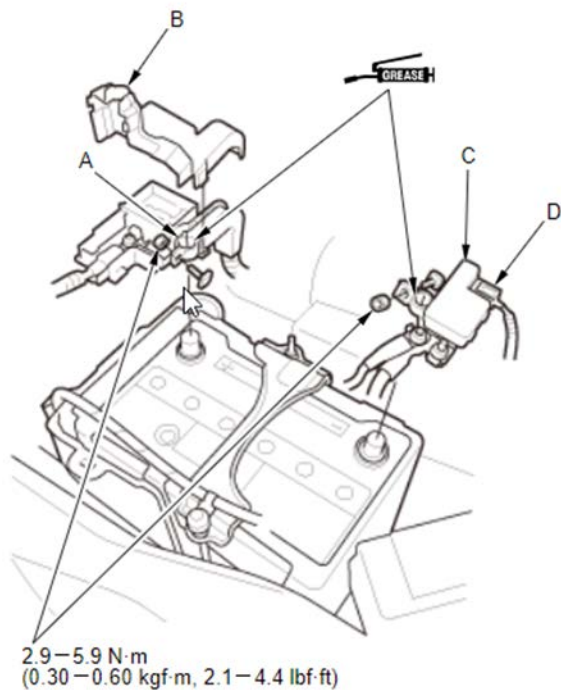

29. Turn the ignition to ON, but do not turn the engine on. After the fuel pump runs for about **2 seconds**, the fuel line will be pressurized. Repeat two or three times, then make sure there is no fuel leakage.
30. Install the fuel tank unit access panel.
31. Install the remaining parts in the reverse order of removal.
32. Clear all DTCs using an i-HDS.
33. *California residents only:* Fill out a Vehicle Emissions Recall – Proof of Correction certificate and use **GHZ** as the recall number. Have the service consultant give the certificate to your client and advise him or her to keep it as proof that the recall was completed. Your client will need to submit this certificate to the DMV only if the DMV requests it. If you need more certificates, use reorder number **Y0657**.

Vehicle Emission Recall - Proof of Correction				
License Number	Make	Year Model	Body Type	Vehicle Identification Number <div style="border: 1px solid black; display: flex; justify-content: space-between; height: 20px; width: 100%;"></div>
Manufacturer _____			Recall Number <b>GHZ</b>	
The above described vehicle has been repaired, modified and/or equipped with new emission control devices to meet applicable California Emission Control Laws.				
Dealer's Name		Address, City, State and Zip		
Date	Dealership's Authorized Signature			
	X			
Return this certificate to DMV only when required - otherwise retain for your records.				

Y0657
ACL 24832 (0212)