

January 17, 2024

Version 1

Safety Recall: 2018–20 HR-V (2WD) Fuel Pump Motor

AFFECTED VEHICLES

Year	Model	Trim Level	VIN Range
2018–20	HR-V (2WD)	ALL	Check the iN VIN status for eligibility.

BACKGROUND

On December 18, 2023, American Honda notified NHTSA of its intention to initiate a **STOP SALE** and **safety recall** for a certain number of 2018–20 HR-V units in order to replace the fuel pump motor manufactured with defective impellers.

Due to swelling of the fuel pump motor impeller, the fuel pump may seize and stop working. A defective impeller may cause the fuel pump to become inoperative, which could prevent an engine from functioning as intended. This limitation may cause a loss of motive power or a stall while being driven, increasing the risk of a crash or injury, creating a safety hazard.

If this bulletin appears during an iN VIN status inquiry, the vehicle is subject to a **safety recall**. Any affected vehicles in your dealer inventory are on **STOP SALE** until further notice. Refrain from calling Tech Line for updates.

CUSTOMER NOTIFICATION

Owners of the affected vehicles will be sent a notification of this campaign. They will be informed that due to a limited supply of parts (at this time) Honda is **prioritizing** the repair of customer vehicles experiencing symptoms related to this recall.

When **adequate replacement parts** become available, Honda will send a follow-up letter to customers instructing them to schedule an appointment for all vehicles affected by this recall. If a customer experiences the known symptoms associated with this **safety recall** (see CORRECTIVE ACTION), they are instructed to contact their local Honda dealer for the repair.

For any questions or concerns customers may have, you may have them contact American Honda's Customer Support & Campaign Center at **1-888-234-2138**.

The following suggested text should be included on any repair order for an already sold affected vehicle that comes in for service. This information should be printed out completely any time service is conducted on an affected vehicle, and the recall repair has not yet been completed. Depending on parts availability, the normal procedures under SOM 7.2.1 will apply for this recall.

Suggested Verbiage to be Included on the Repair Order

Customer was advised that:

The vehicle is subject to a recall affecting the fuel pump motor. The parts necessary to complete the recall repair are currently limited. Vehicles with eligible VINs and the following symptoms: difficulty starting, engine hesitation while driving, and/or an illuminated check engine light displayed with DTC P0087, are eligible for immediate repair. Once parts repair kits are available, if the vehicle has not been repaired, the registered owner of the vehicle will receive a notice to bring the vehicle in for a replacement of the components, regardless of symptom.

CUSTOMER INFORMATION: The information in this bulletin is intended for use only by skilled technicians who have the proper tools, equipment, and training to correctly and safely maintain your vehicle. These procedures should not be attempted by "do-it-yourselfers," and you should not assume this bulletin applies to your vehicle, or that your vehicle has the condition described. To determine whether this information applies, contact an authorized Honda automobile dealer.

IMPORTANT NOTICE

Vehicles that are **both** shown as an eligible VIN and experiencing any of the following symptoms will be **prioritized** for repair: difficulty starting, engine hesitation while driving, and/or an illuminated check engine light displayed with DTC P0087 (Fuel Rail Pressure Too Low) stored.

CORRECTIVE ACTION

Replace the fuel pump motor.

NOTE: If the vehicle has any of the symptoms listed in BACKGROUND, you must apply this bulletin before attempting any other repairs. If the symptoms remain after the recall repair is complete, only attempt further repairs (such as replacing the high-pressure fuel pump) after authorized troubleshooting.

PARTS INFORMATION

NOTE:

- Due to a limited supply, parts will be allocated to your dealership **based on availability**.
- Prioritize repairing customer vehicles that meet both the VIN status eligibility **and** exhibit a known symptom such as: difficulty starting, engine hesitation while driving, and/or an illuminated check engine light with DTC P0087 (Fuel Rail Pressure Too Low).

Part Name	Part Number	Quantity
Fuel Pump Motor Kit	06170-TRN-305	1
Shift Knob Screws (CVT Only)	54903-SYA-981	2

For dealers experiencing a strong fuel smell from storing a fuel pump motor replaced under this service bulletin, the fuel pump motor may be disposed of immediately in accordance with local regulations. This only applies to the fuel pump motor replaced under this service bulletin. The published retention policy remains in effect for all other parts.

If you have any questions about this exception or other parts retention issues, contact the WPI Administrative Office at **937-642-2737**.

TOOL INFORMATION

Tool Name	Part Number	Quantity
Fuel Nut Wrench (Fuel Sender Wrench)	07AAA-S0XA100	1
Fuel Module Separator Set	07AAF-T5RA100	1

WARRANTY CLAIM INFORMATION

Operation Number	Description	Flat Rate Time	Defect Code	Symptom Code	Template ID	Failed Part Number
3101EH	Replace the fuel pump motor.	1.7 hr	6FE00	VGX00	A24026A	17045-T7W-A00

Skill Level: Repair Technician

⚠ WARNING

Fuel pump motor removal exposes fuel, which can ignite, causing a fire or explosion.

This can cause serious injury or death.

Always work in a well-ventilated area and keep sparks or open flames away.

1. Remove the fuel fill cap to relieve the pressure in the fuel tank.
2. Remove the PGM-FI main relay 2 from the under-dash fuse/relay box.

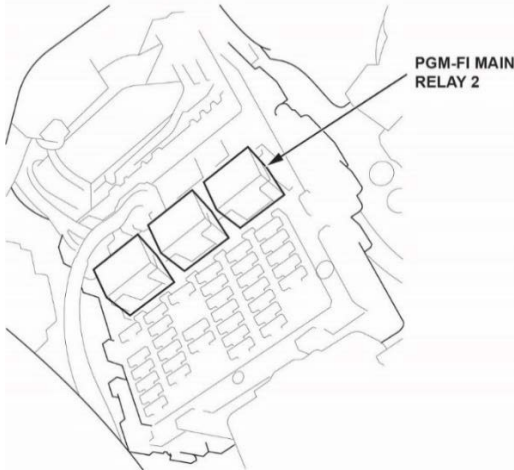

3. Start the engine, and let it idle until it stalls.
4. Turn the ignition to OFF.
5. Install the PGM-FI main relay 2.
6. Disconnect both 12-volt battery terminals.

NOTICE

To protect the terminal connector from damage, do not hold it when removing the negative terminal.

NOTE:

- Always disconnect the negative terminal first.
- Do not disconnect the 12-volt battery sensor from the cable.

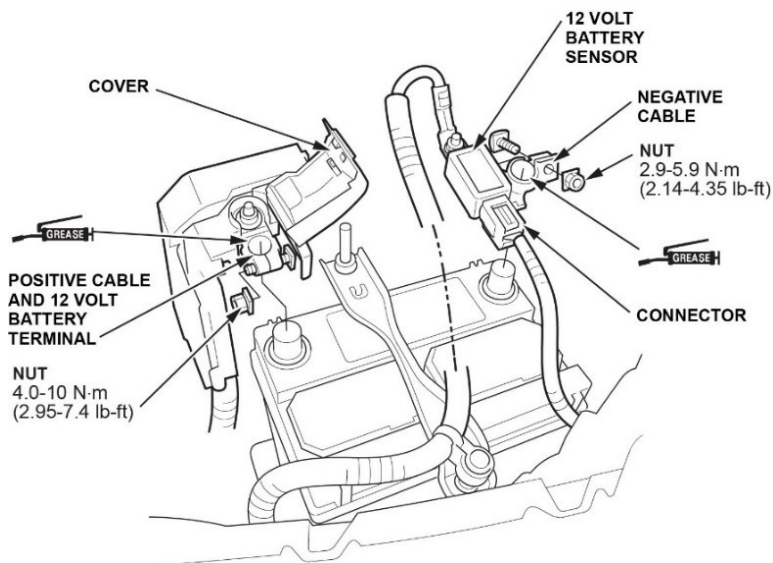

7. Remove the passenger's dashboard undercover.

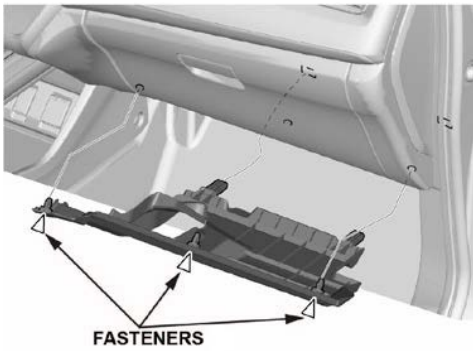

8. Remove the shift lever knob.

CVT Models

NOTICE

Do not remove the special grease applied to the end of the shift lever.

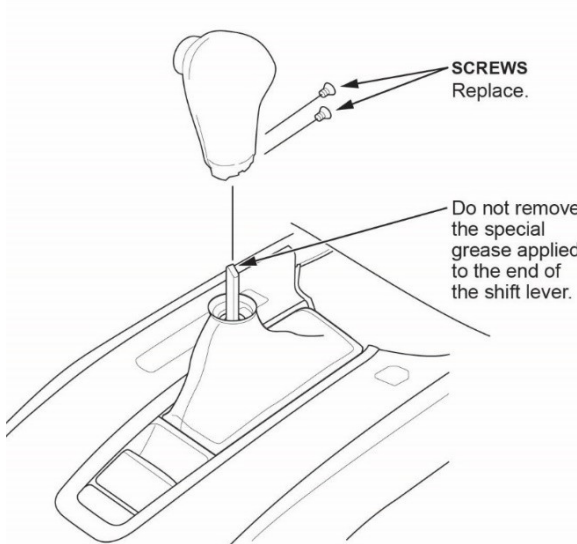

M/T Models

Lower the shift lever boot to release the hooks from the boot. Then, remove the shift lever knob.

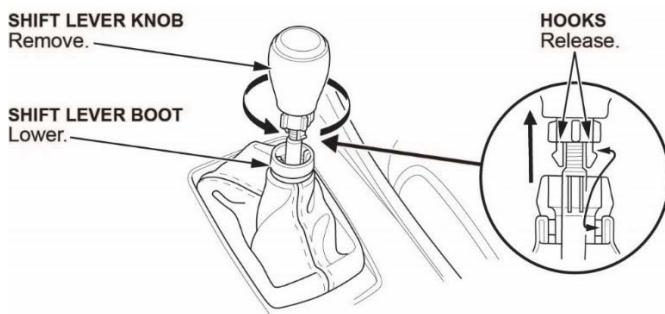

9. Remove the center console switch trim, and disconnect the connector.

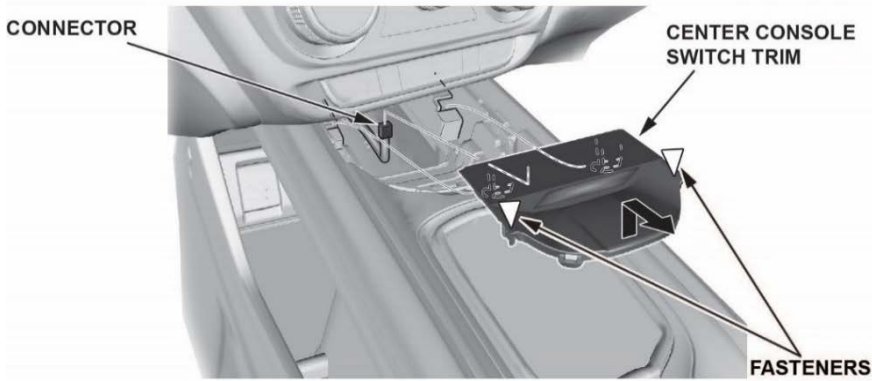

10. Remove the center console panel.

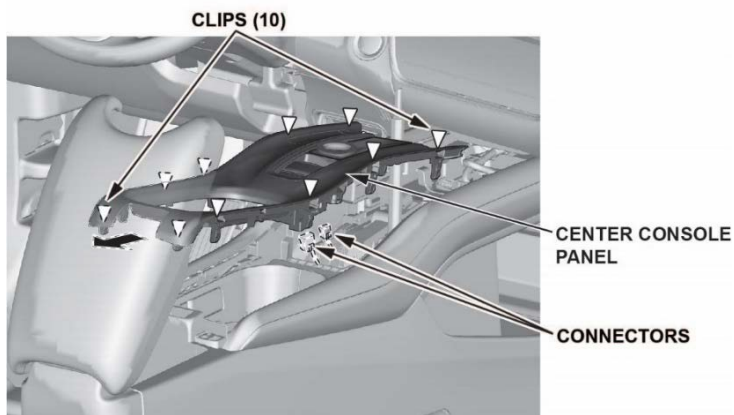

11. *For some models:* Disconnect the connectors.
12. Remove the center console pad by removing bolts A, and loosening bolts B.
13. Disconnect the connector and remove the harness clip.

NOTE: Make sure not to drop the bolts when loosening them.

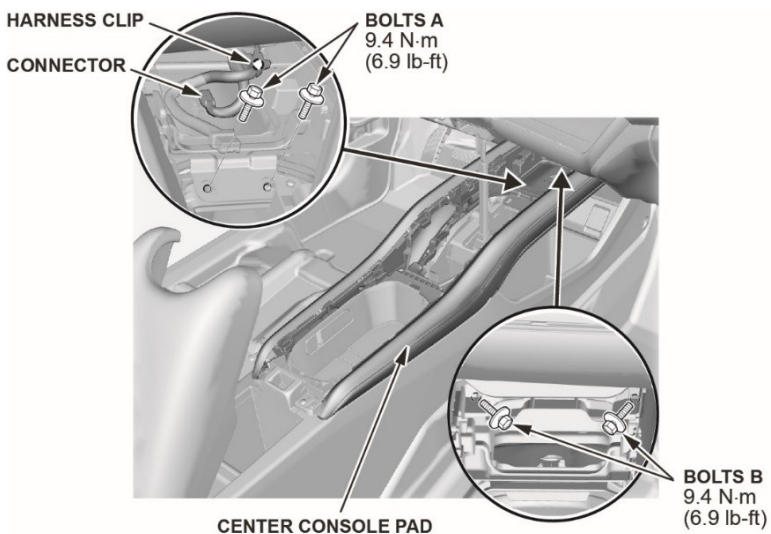

14. Remove the center console pad, and disengage the brackets from the bolts.

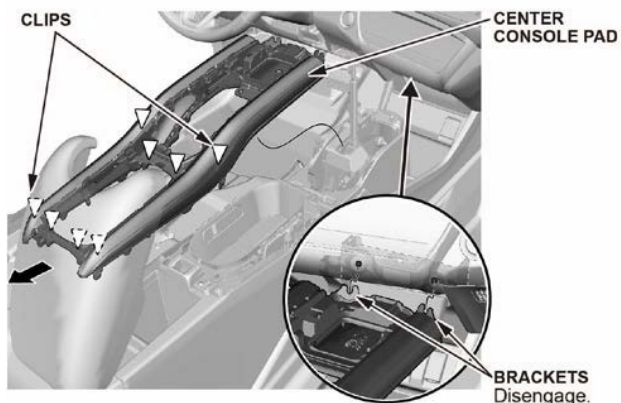

15. Remove the center console rear trim, and disconnect the connector.

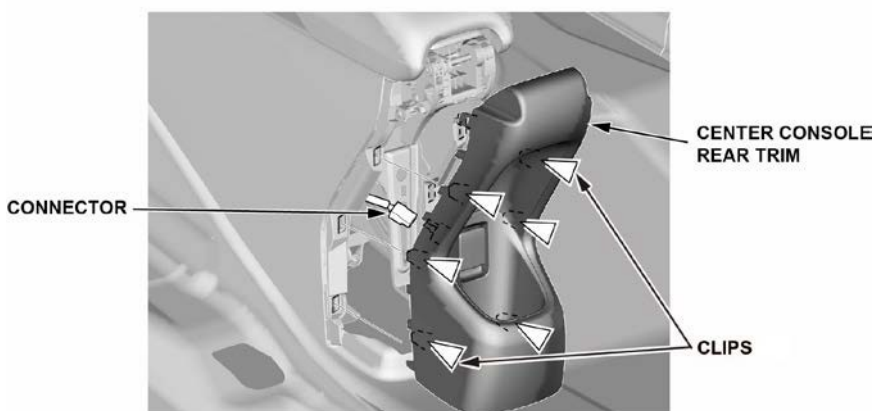

16. Remove the console front mat.

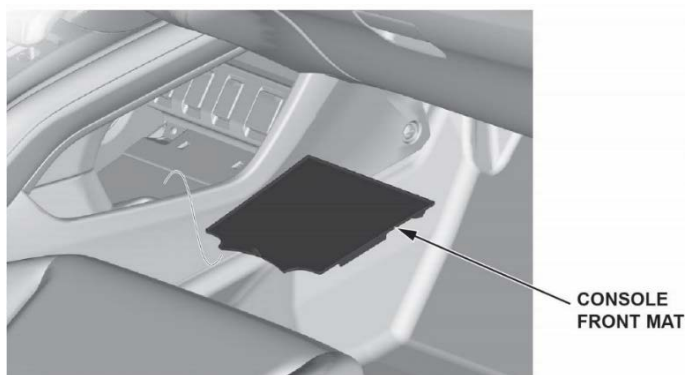

17. Remove the console middle cover.

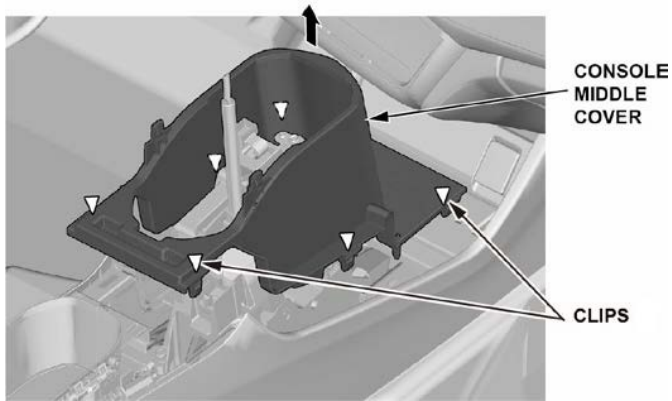

18. Remove the console box mat.

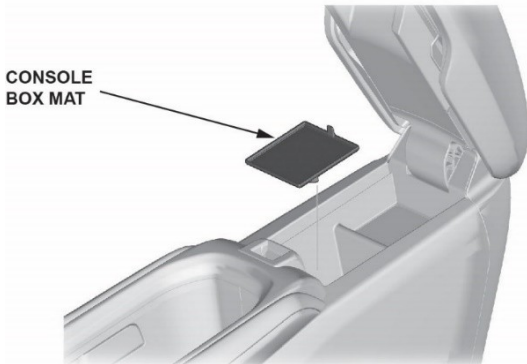

19. Remove the bolts, clips, and the harness clip.

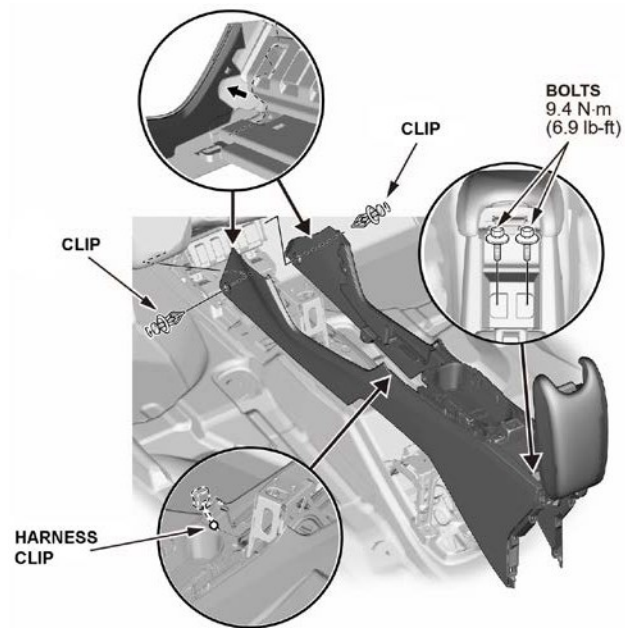

20. Remove the center console.

21. *M/T Models Only*: Remove the shift lever housing.

NOTE: The shift cable is attached to the shift lever.

- Remove the spring pin and washer. Do not lose them, they will be reused for installation.
- Remove the shift lever housing bolts.

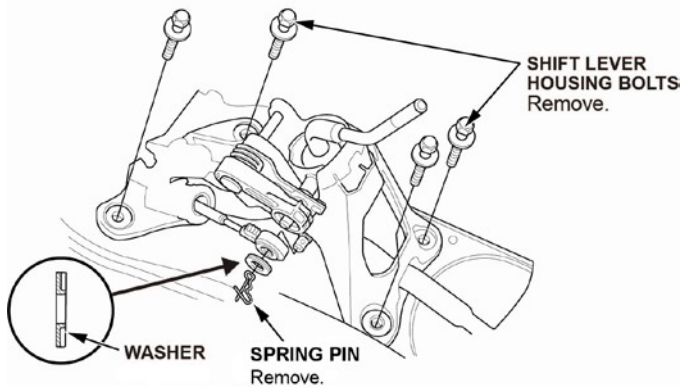

- Unlock the retainer lock.

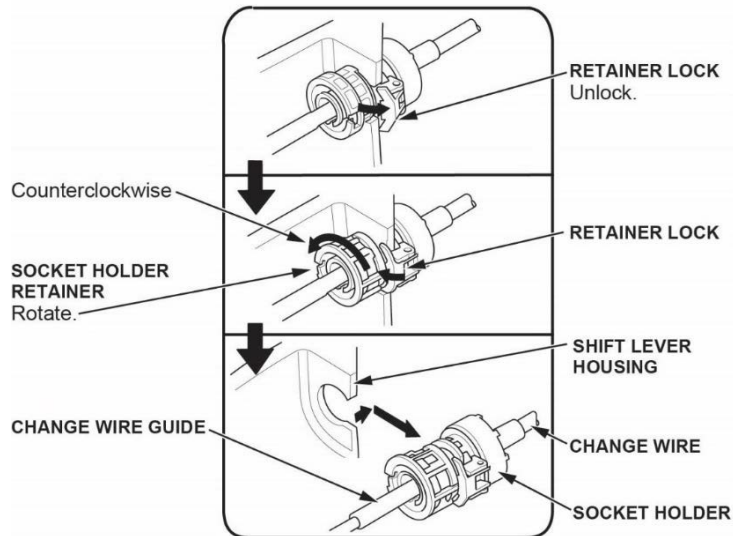

- Rotate the socket holder retainer counterclockwise until it stops, then push the retainer lock into the socket holder retainer to lock the retainer.
- Slide the socket holder and change wire out of the shift lever housing.

NOTE:

- Do not remove the change wire by pulling the change wire guide.
- Do not bend the change wire excessively.

- Remove the clip.

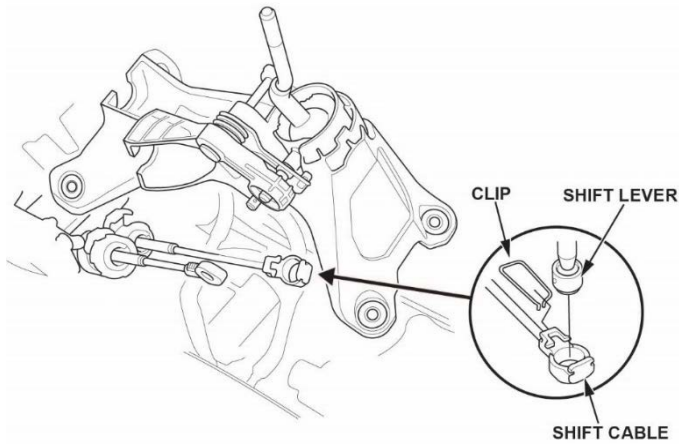

- Disconnect the shift cable from the shift lever.

22. CVT Models Only: Remove the shift lever.

NOTE: The shift cable is attached to the shift lever.

- Shift to Reverse by pushing down the shift lock release, then moving the shift lever to R.

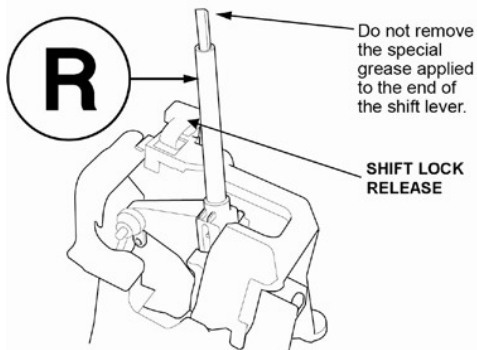

- Insert a **6 mm (0.236 in)** pin with no burrs into the positioning holes.

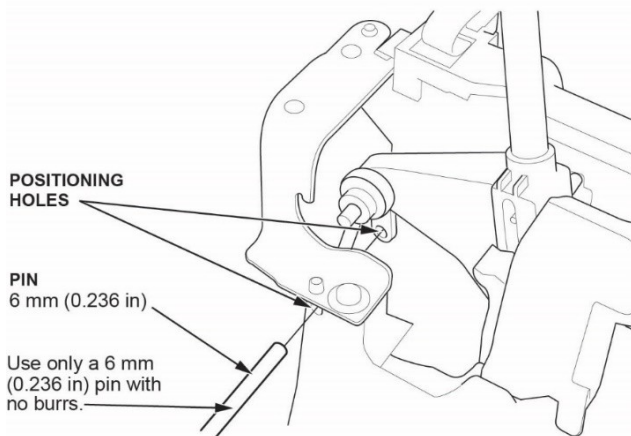

- Remove the shift cable end nut.

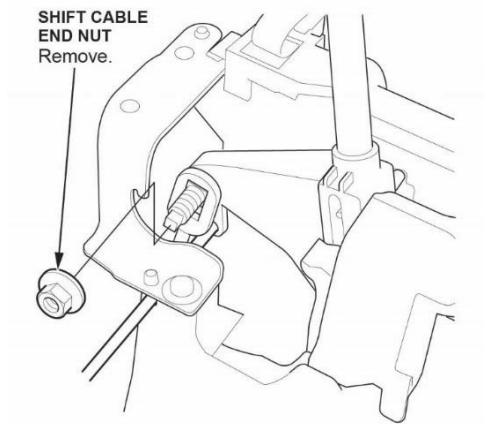

- Expand the lock tab.

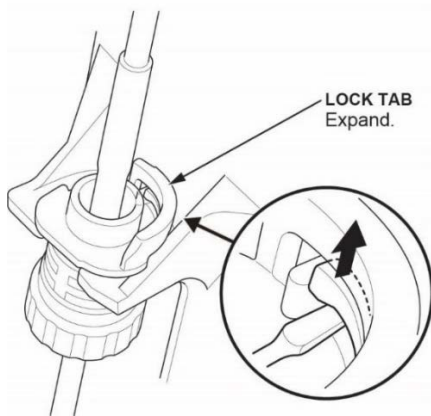

- Rotate the socket holder retainer counterclockwise until it stops, then remove the shift cable.
NOTE: Do not remove the shift cable by pulling the shift cable guide.

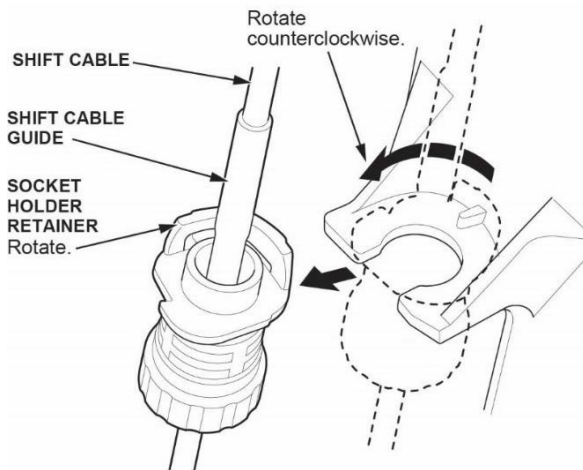

- Remove the shift cable end.

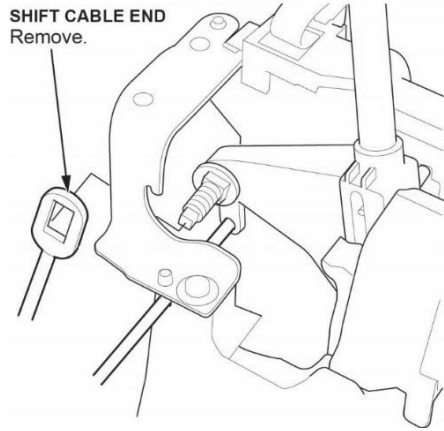

- Disconnect the connectors.

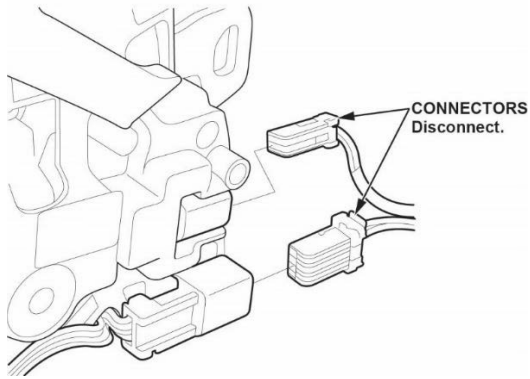

- Remove the harness clamps.

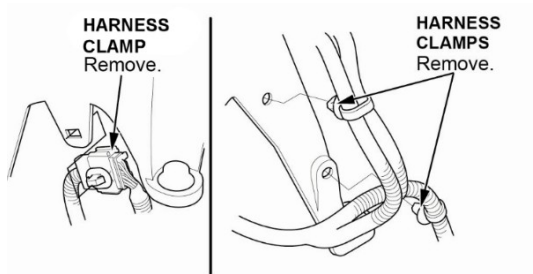

- Remove the shift lever assembly.

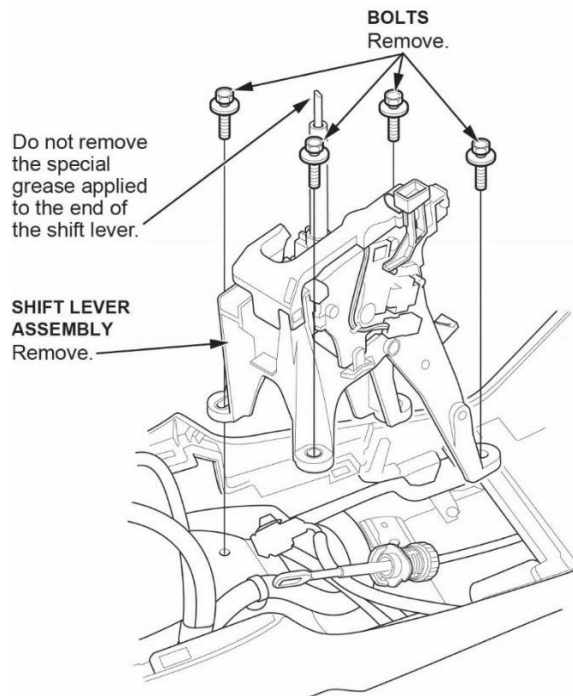

23. Remove the fuel tank unit access panel, and disconnect the connector.

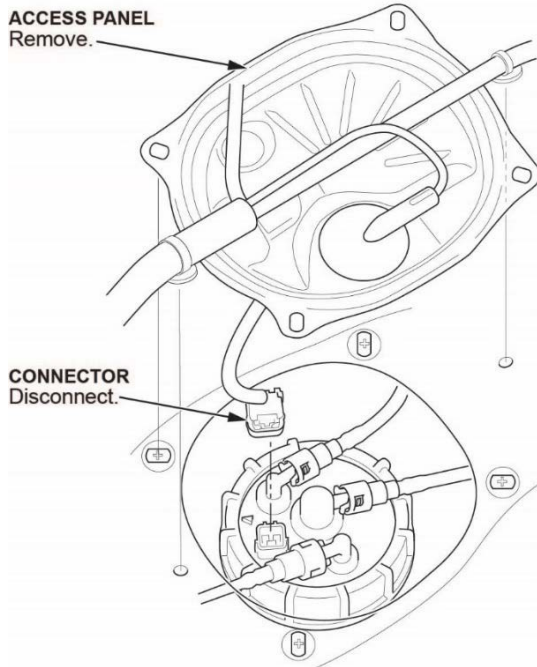

24. Place a rag or shop towel over the quick-connect fitting and hoses, and disconnect them.

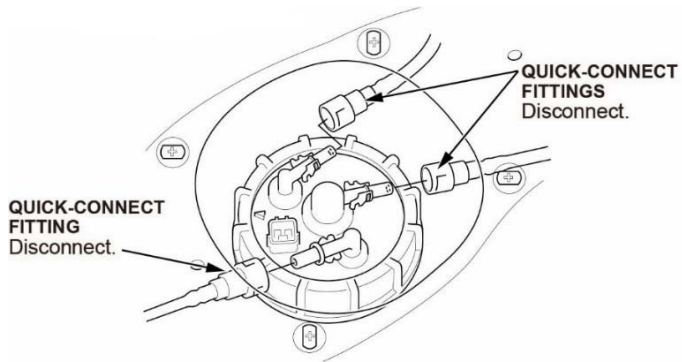

25. Loosen the fuel tank unit locknut using the Fuel Sender Wrench (T/N 07AAA-S0XA100).

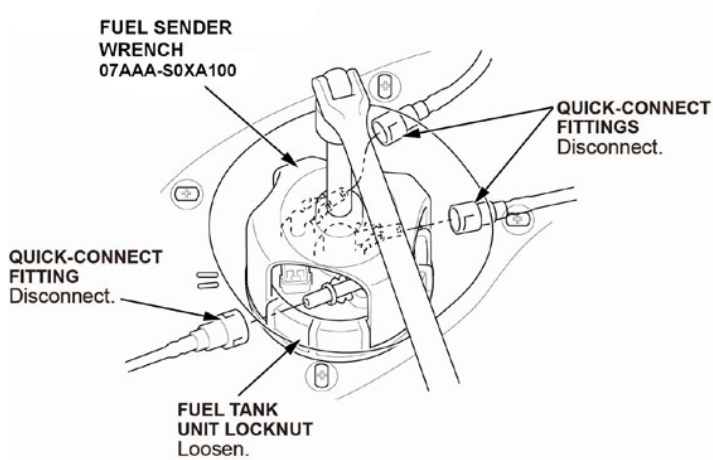

26. Remove the fuel tank unit locknut, then remove the fuel tank unit.

NOTE:

- After unlocking the fuel tank unit cam lock ring, clean the top of the fuel pump flange and adjacent areas to make sure it's free of dirt, dust, and debris.
- Do not bend or twist the fuel level sensor arm excessively. This may damage the fuel level sensor or cause it to send inaccurate readings.

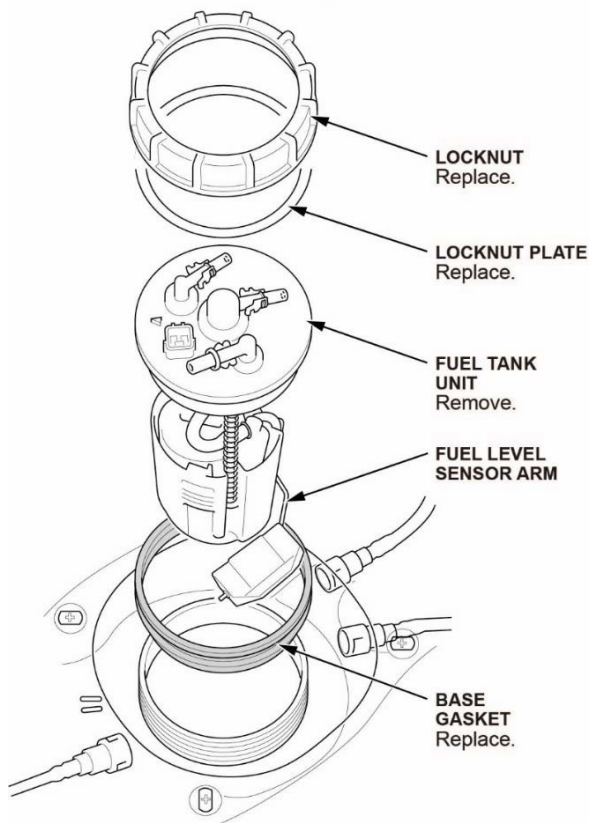

27. Prepare the fuel tank unit and parts to be replaced.

NOTE: Take a photo of the fuel tube and wire harness, and note their routing for assembly. There are various types of routing.

28. Spread the wire harness clamps and remove the wire harness. Make sure not to damage the wire harness.

NOTICE

Do not spread the clamps too wide. Spreading them too wide may damage them.

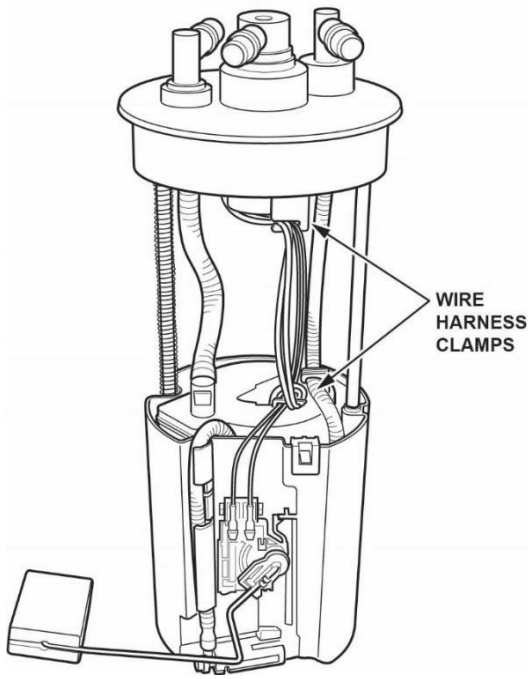

29. Press the tab on the fuel level sensor to release the lock. Then, push up on the fuel level sensor.

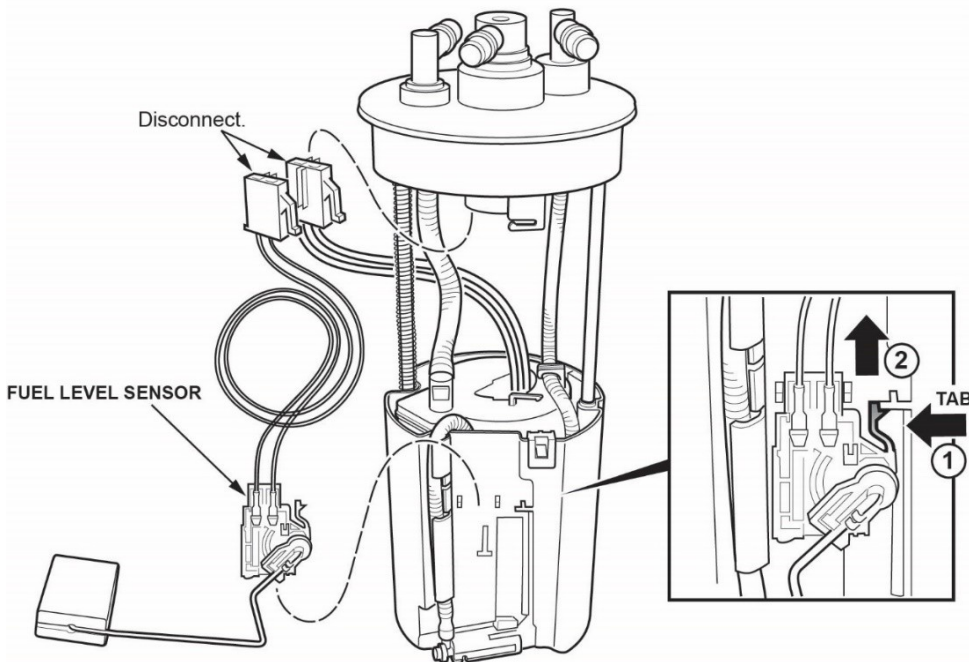

30. Remove the fuel level sensor from the fuel tank unit.

31. Remove the E-rings and discard them.

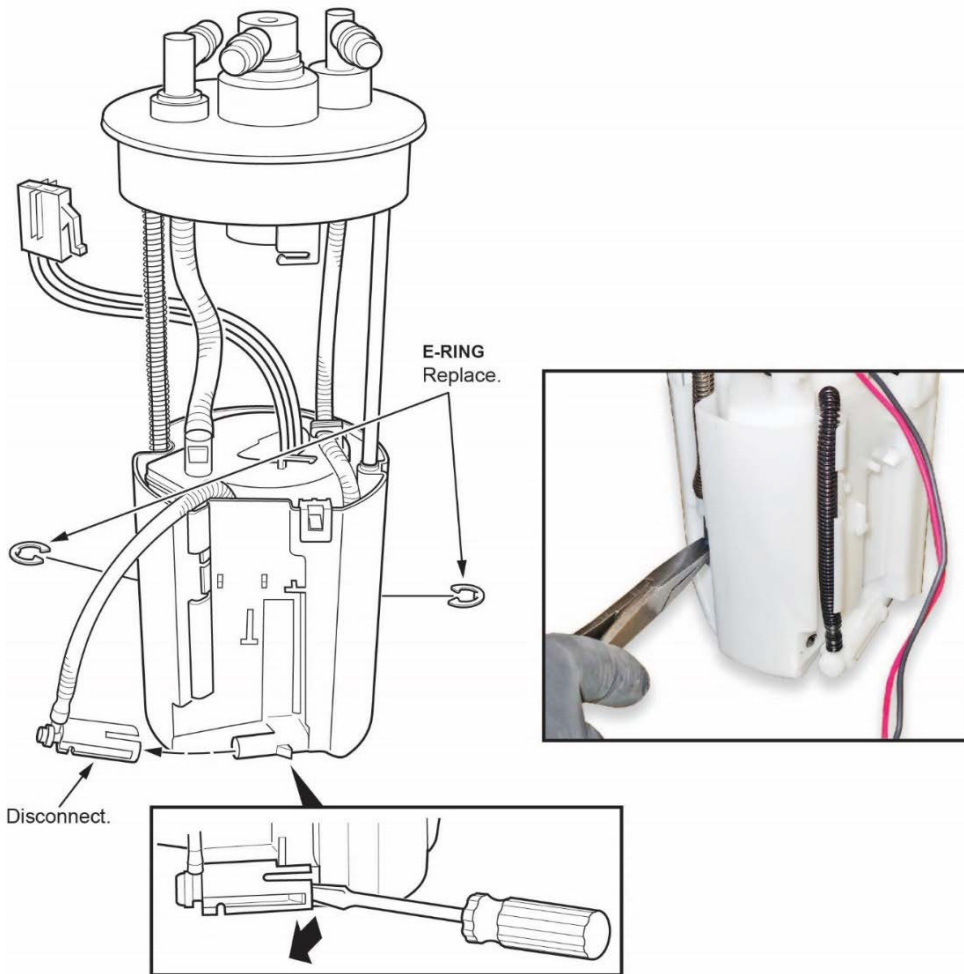

32. Disconnect the joint at the bottom of the reservoir.

33. Remove the fuel filter assembly from the reservoir by releasing the three clips.

NOTICE

Do not spread the clips too wide. Spreading them too wide may damage them.

NOTE:

- Use the fuel module separator on two of the clips.
- The spring may slide off the sliding shaft. Retain this spring. It will be used during assembly.

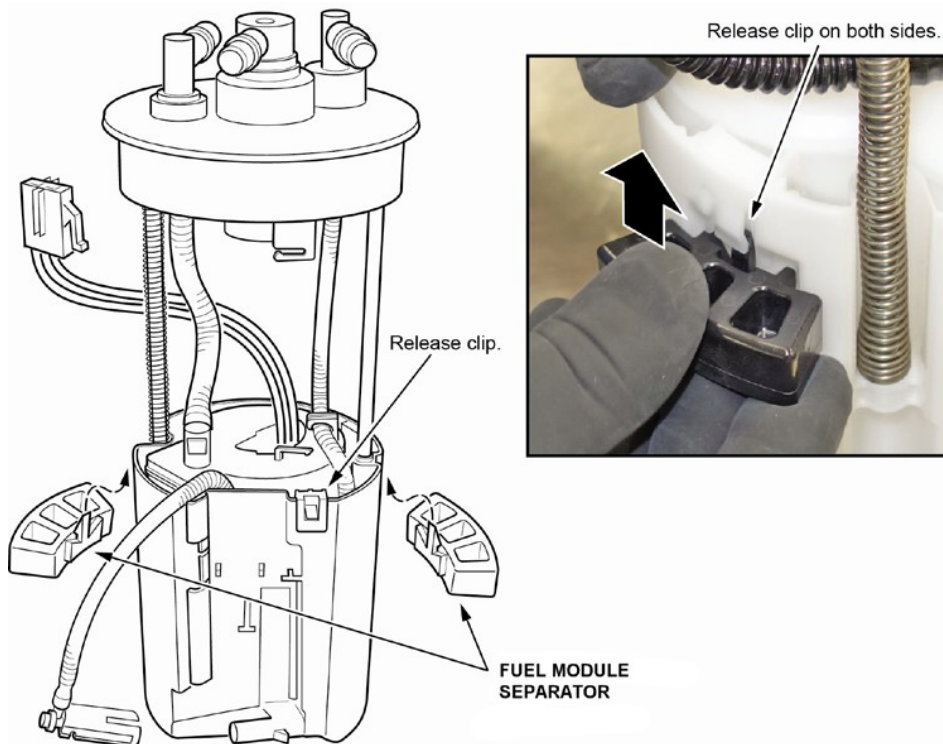

34. Release the three clips at the base of the fuel pump assembly.

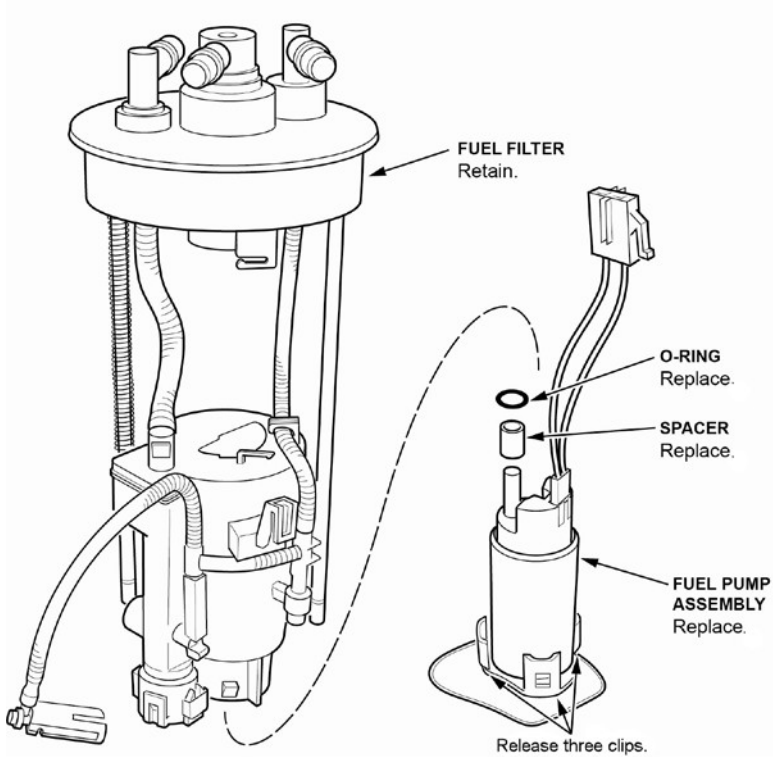

35. Pull the fuel pump assembly out of the fuel filter.

36. Install the new spacer onto the new fuel pump motor.

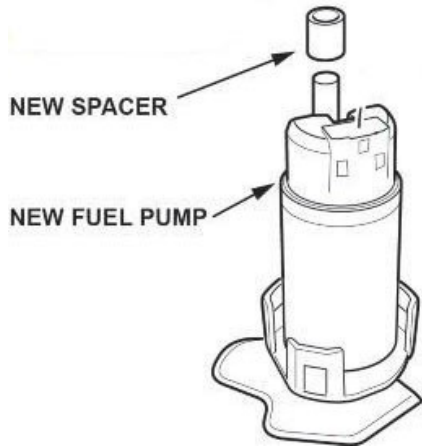

37. Install the new O-ring, then lubricate ONLY the outside edge of it, using clean engine oil.

NOTE: Do not pinch the O-ring during installation.

NEW O-RING

Lubricate after installing.

Do not lubricate the inside of the o-ring.

NEW SPACER

NEW FUEL PUMP

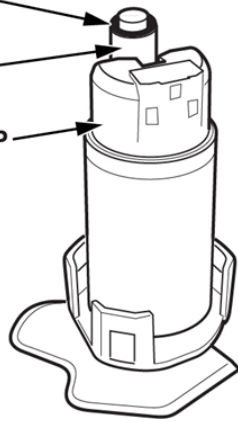

38. Install the new harness making sure the connection is secure and the connectors are firmly locked into place.

NEW O-RING

Lubricate after installing.

Do not lubricate the inside of the o-ring.

NEW SPACER

NEW FUEL PUMP

NEW HARNESS

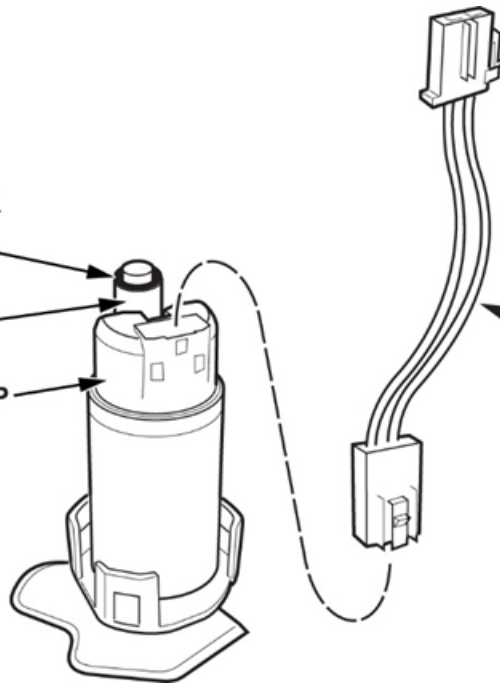

39. With the palm of your hand press the fuel pump into the suction fuel filter.

Click here to view video:

▶ PLAY VIDEO

NOTICE

When pressing the fuel pump into the suction filter, make sure you do so with a single firm push. Failure to do so may damage the O-Ring. If it is seated properly, you will hear a click.

If you do not hear the click, remove all parts, and inspect the O-ring for damage. If the O-ring is damaged it must be replaced. Reassemble using the above process.

NOTE:

- When inserting the pump be careful not to break the suction filter.
- If the O-ring is damaged; replace it with a new one.
- After installing the fuel pump to the suction filter, make sure the clips are firmly attached to the new fuel pump.

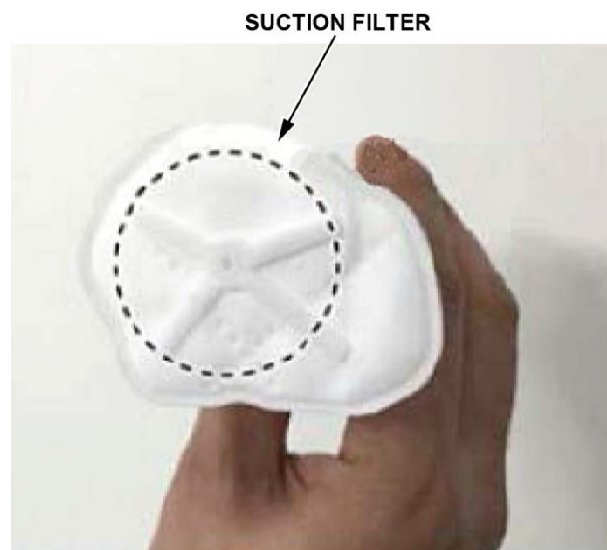

GOOD



NO GOOD

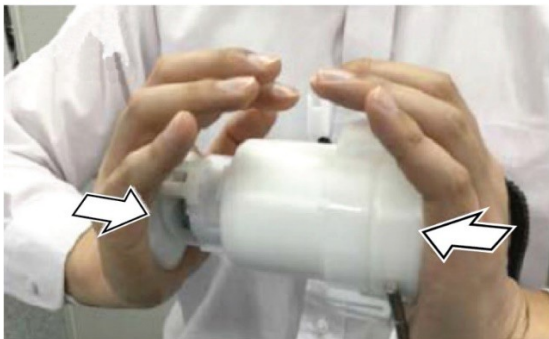

39. Install the fuel filter assembly to the reservoir.

NOTE:

- Install the spring onto the sliding shaft, and make sure it is lined up when installing the fuel filter.
- Make sure the fuel tube is routed exactly as shown in the photo taken before disassembly.
- Make sure the three clips are fully engaged.

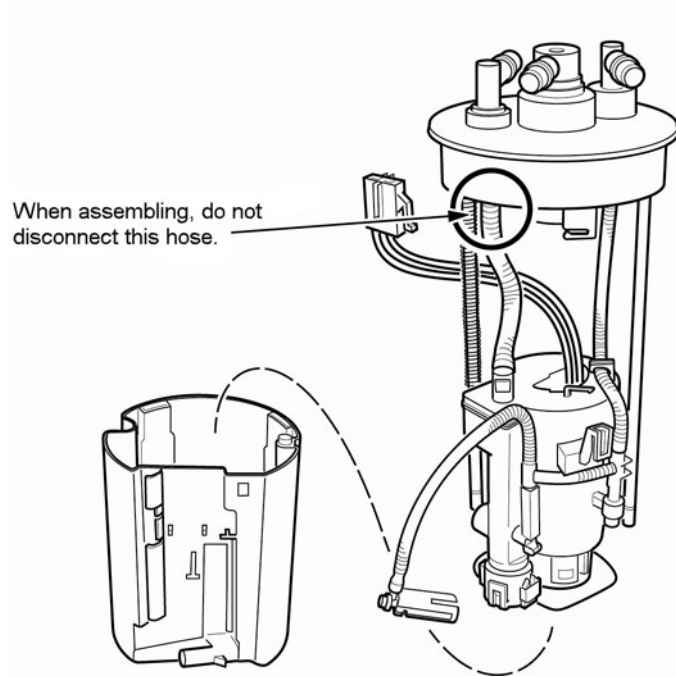

40. Install the new E-rings.

NOTE: After installation, make sure the E-rings can be rotated with your finger. If they cannot be rotated, the E-rings may not be fully seated or may be incorrectly installed.

41. Install the fuel level sensor to the reservoir. Make sure the lock is engaged and the connection is secure.

NOTICE

Do not bend or twist the fuel level sensor arm excessively. This may damage the fuel level sensor or cause it to send inaccurate readings.

42. Install the wiring harness to the clamps.

NOTICE

Do not spread the clamps too wide. Spreading them too wide may damage them.

NOTE:

- Clip in the smaller harness wires followed by the larger wires.
- Make sure not to damage the wire harness.
- Make sure to route the wire harness **exactly** as shown in the photo taken before disassembly.

HARNESS ROUTING

Clip in the smaller harness wires followed by the larger wires.

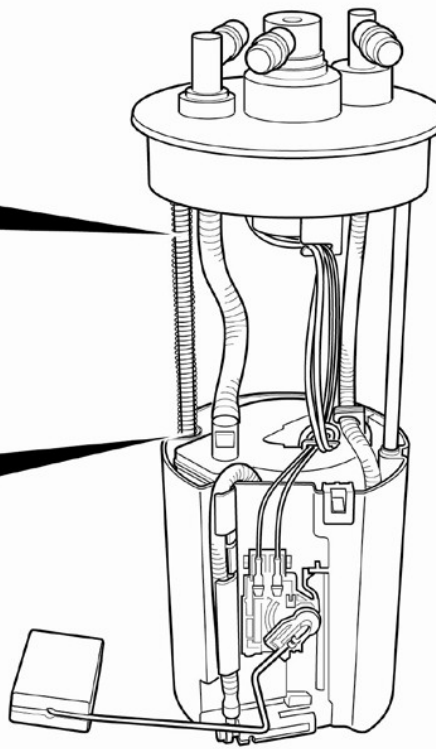
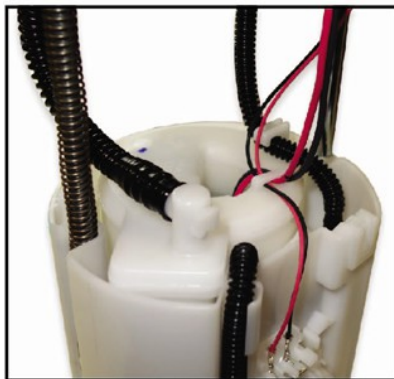

43. While compressing the fuel tank unit, make sure the movement is smooth and the fuel tube and wiring harness do not stretch, pinch, or bind.

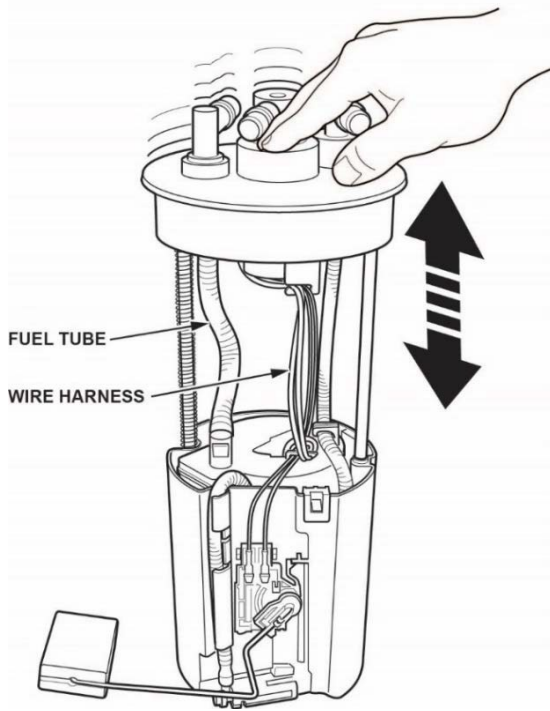

44. Partially insert the fuel tank unit into the fuel tank with a new base gasket.

NOTICE

Do not bend or twist the fuel level sensor arm excessively. This may damage the fuel level sensor or cause it to send inaccurate readings.

NOTE:

- Before installing the new O-ring, clean the fuel tank around the fuel pump opening where the O-ring will seat. The tank opening must be free of dirt, dust, and debris.
- Be careful not to damage the O-ring.
- Do not coat the O-ring with any oil.

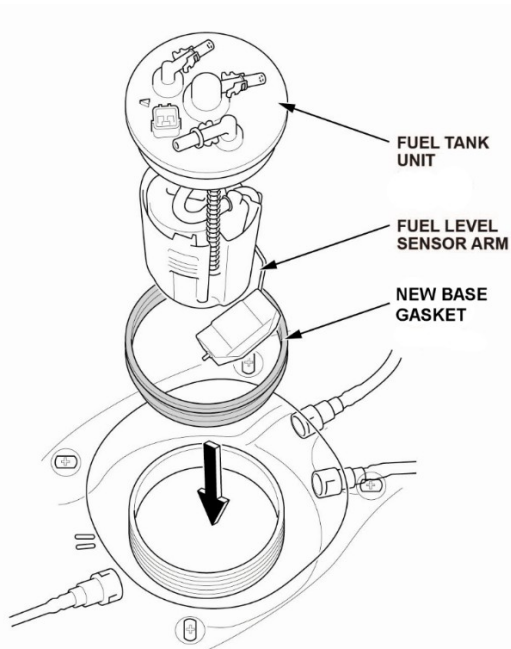

45. Line up the marks on the fuel tank and fuel tank unit as shown, then insert the fuel tank unit.

NOTE: To avoid a fuel leak, make sure the base gasket is not pinched.

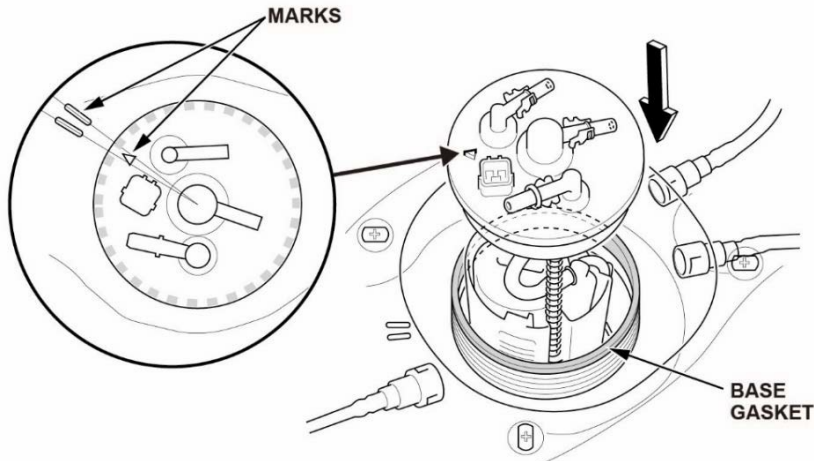

46. Hold the fuel tank unit vertically, and tighten the new fuel tank unit locknut with a new locknut plate by hand.

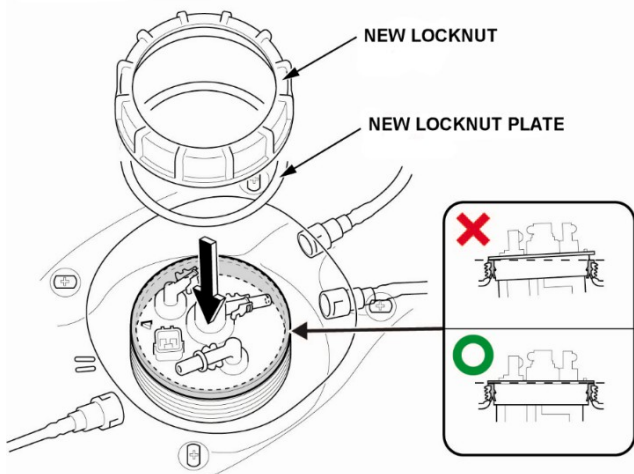

47. Tighten the fuel tank unit locknut to the specified torque using the fuel sender wrench.

NOTICE

If the locknut is not properly installed, the fuel tank can be damaged and will require replacement.

NOTE:

- After tightening, make sure the marks are still lined up.
- To avoid a fuel leak, make sure the base gasket is not pinched.

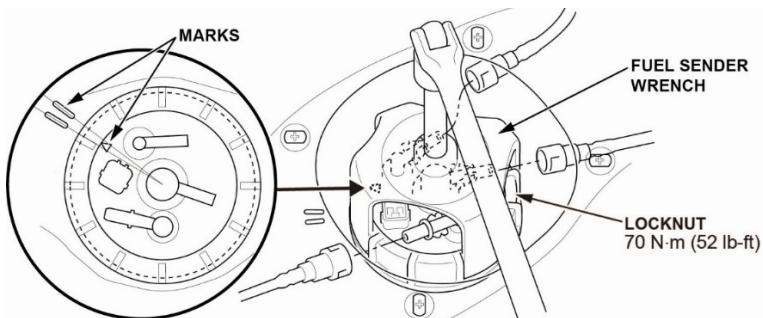

48. If the marks do not line up, friction between the fuel tank unit and the locknut may cause the fuel tank unit to turn while tightening. Observe the difference (shaded area), and loosen the locknut until the fuel tank unit can be rotated. Rotate the fuel tank unit **counter-clockwise** by the same amount, and repeat the tightening process.

NOTE: Repeat this step as necessary until the marks are lined up when the locknut is tightened to the specified torque.

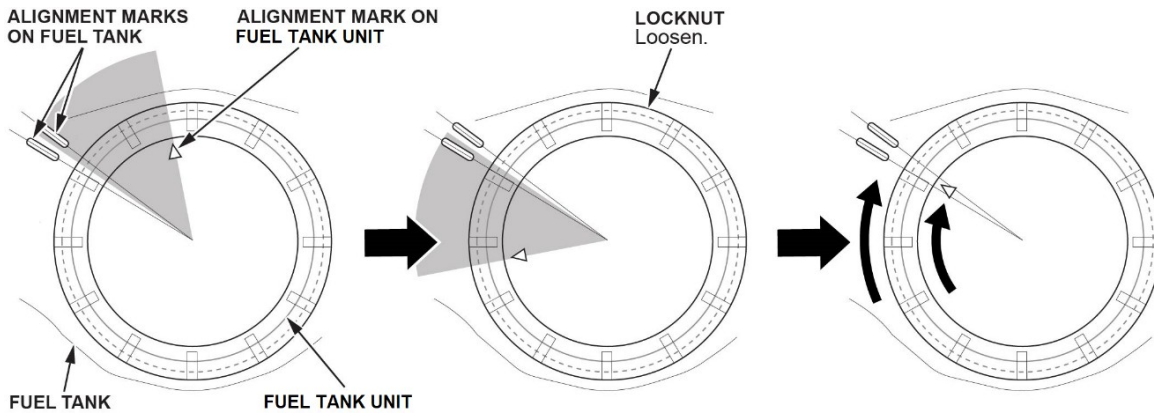

49. Remove the quick-connect fitting retainers on the fuel tank unit, then install the new retainers to the quick-connect fittings as shown.

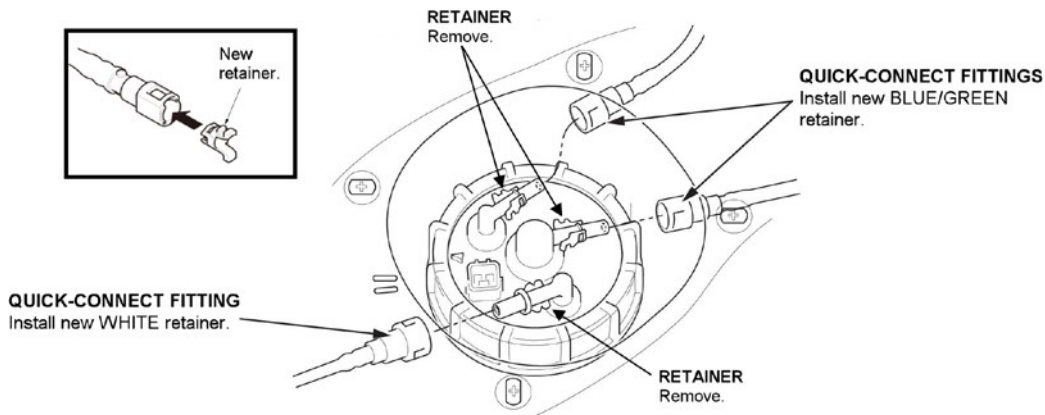

50. Connect the quick-connect fittings to the fuel tank unit.

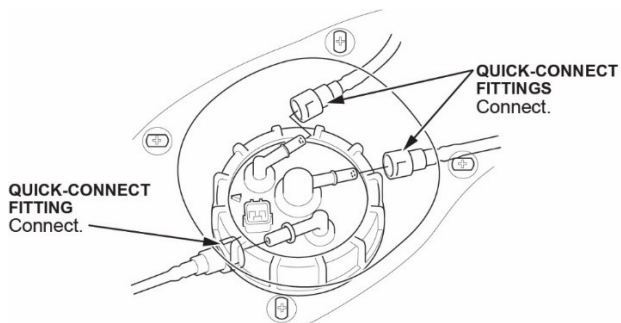

51. Connect the fuel tank unit connector.

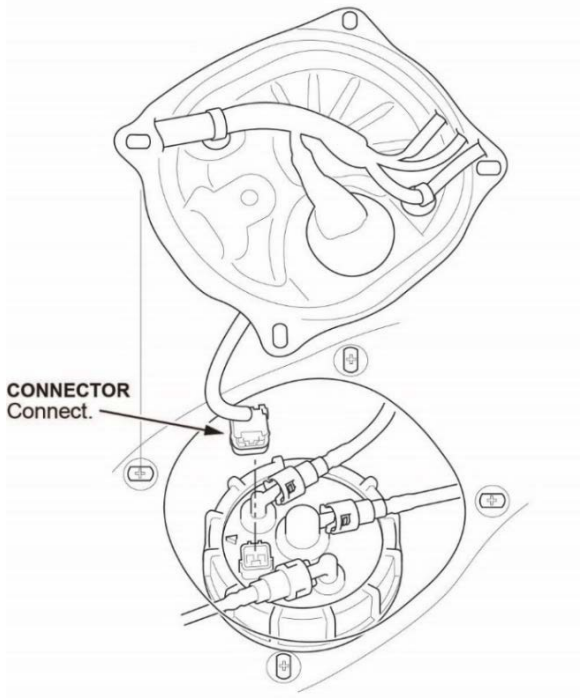

52. Connect the 12-volt battery terminals.

NOTE:

- Always reconnect the negative terminal last
- Do not disconnect the 12-volt battery sensor from the cable.

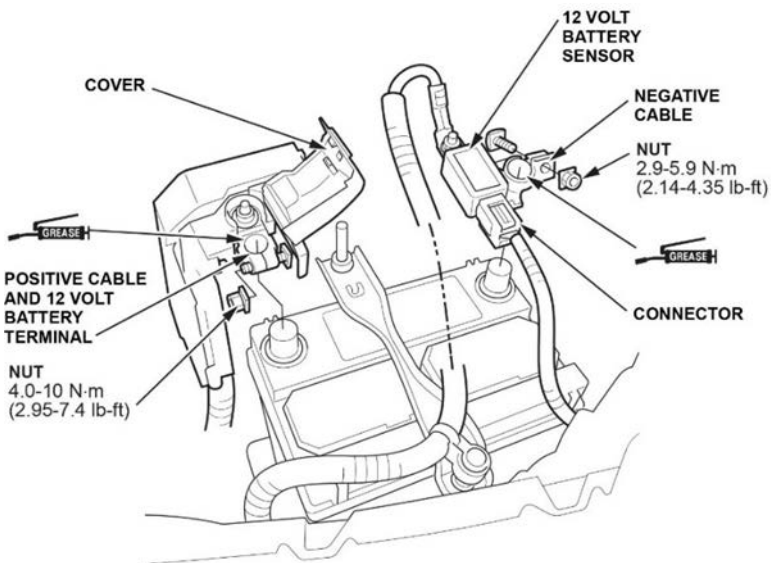

53. Check for fuel leaks by turning the ignition to ON, but do not turn the engine on. After the fuel pump runs for about **2 seconds**, the fuel line will be pressurized. Repeat two or three times, then make sure there is no fuel leakage.
54. Install the fuel tank unit access panel.
55. Install the remaining parts in the reverse order of removal.

NOTE:

CVT Models Only: Replace the two screws when installing the shift knob.

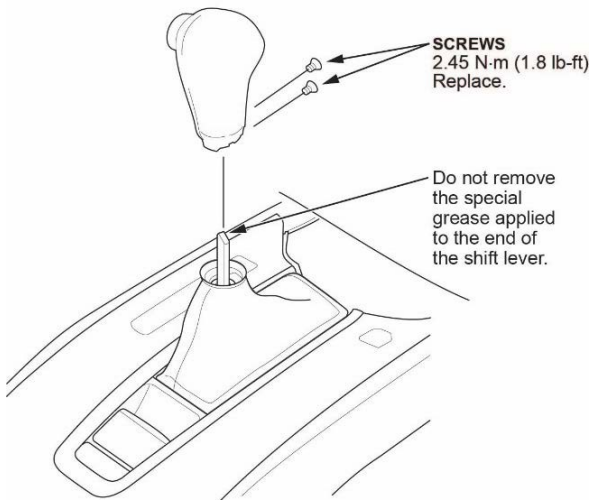

M/T Models Only: Inspect the spring pin that secures the shift wire to the shifter. If the spring pin is damaged or does not secure the shift wire, replace it.

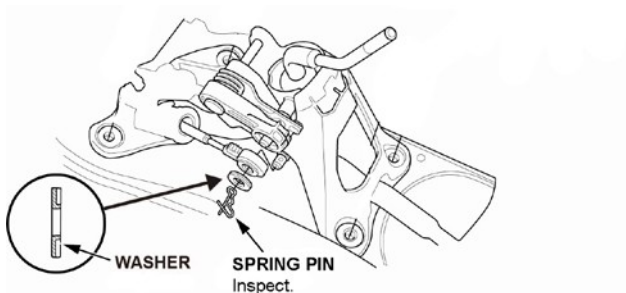

56. Clear all DTCs using an i-HDS.

57. *California residents only:* Fill out a Vehicle Emissions Recall – Proof of Correction certificate, and use **VGX** as the recall number. Have the service advisor give the certificate to your customer, and advise him or her to keep it as proof that the recall was completed. Your customer will need to submit this certificate to the DMV only if the DMV requests it. If you need more certificates, use reorder number **Y0657**.

Vehicle Emission Recall - Proof of Correction				
License Number	Make	Year Model	Body Type	Vehicle Identification Number
				<input type="text"/>
Manufacturer _____			Recall Number VGX	
The above described vehicle has been repaired, modified and/or equipped with emission control devices to meet applicable California Emission Control Laws.				
Dealer's Name		Address, City, State and Zip		
_____		_____		
Date	Dealership's Authorized Signature			
_____	_____			
Return this certificate to DMV only when required - otherwise retain for your records.				

Y0657 ACL 24832 (0212)