

SAFETY RECALL
 NORTH AMERICA
High Voltage Battery



Reference: B9A / NHTSA 23V-787

FCA US LLC



Remedy available for
 2021-2024 (JL) Jeep Wrangler PHEV

Template Version 1.0

Revision	Edition	Detail
0	February 2024	Initial Version.

SYMPTOM DESCRIPTION

The High Voltage (HV) battery on about 32,125 of the above vehicles may fail internally. The defect has not been identified and the root cause is still being investigated. An internally failed HV battery could lead to a vehicle fire with the ignition on or off. A vehicle fire can result in increased risk of occupant injury and/or injury to persons outside the vehicle, as well as property damage.

Customers are advised to refrain from recharging these vehicles and not to park them inside of buildings or structures, or near other vehicles until the vehicle has the final repair completed.

SCOPE

This recall applies only to the above Plug-In Hybrid Electric Vehicles (PHEVs).

NOTE: Some vehicles above may have been identified as not involved in this recall and therefore have been excluded from this recall.

IMPORTANT:

- Some of the involved vehicles may be in dealer new vehicle inventory. Federal law requires you to complete this recall service on these vehicles before retail delivery. Violation of this requirement by a dealer could result in a civil penalty of up to \$27,168 per vehicle.
 - Some of the involved vehicles may be in dealer used vehicle inventory. Dealers should complete this recall service on these vehicles before retail delivery.
 - Dealers should also perform this recall on vehicles in for service.
- Involved vehicles can be determined by using the VIP inquiry process.

REPAIR TO BE PERFORMED

Perform the Battery Pack Control Module (BPCM) Software Update and BPCM Integrity Procedure.

Do not replace the High Voltage battery unless the BPCM Integrity Procedure DTCs indicates a new battery is required.

Also update the Auxiliary Hybrid Control Processor (AHCP), Hybrid Control Processor (HCP), Integrated Dual Charging Module (IDCM), Powertrain Control Module (PCM) and Transmission Control Module (TCM) if updated software exists for any of those modules.

ALTERNATE TRANSPORTATION

Dealers should attempt to minimize customer inconvenience by placing the owner in a loaner vehicle if the vehicle must be held overnight

COMPLETION REPORTING / REIMBURSEMENT

Claims for vehicles that have been serviced must be submitted on the DealerCONNECT Claim Entry Screen located on the Service tab. Claims paid will be used by FCA to record recall service completions and provide dealer payments.

Use the following labor operation numbers and time allowances:

Labor Description	Number	Hrs
Run Pre-Check B9A Battery Integrity Procedure.	18-B9-A1-81	0.2
Run Pre-Check B9A Battery Integrity Procedure and Reprogram Battery Pack Control Module (BPCM) and Run B9A Battery Integrity Procedure.	18-B9-A1-82	0.6

NOTE: Use the related LOPs for updating the AHCP, HCP, IDCM, PCM and TCM if updated software exists for any of those modules.

SAFETY RECALL
 NORTH AMERICA
High Voltage Battery



Reference: B9A / NHTSA 23V-787

FCA US LLC

Related Operations	Number	Hrs
Replace High Voltage Battery Pack	18-B9-A1-50	3.1
Update AHCP/HCP Software	18-B9-A1-51	0.6
Update IDCM Software	18-B9-A1-52	0.2
Update PCM Software.	18-B9-A1-53	0.2
Update TCM Software.	18-B9-A1-54	0.2

Labor Description	Number	Allowance
Floor Plan Reimbursement	95-95-95-97	Calculate See Below

Floor Plan Reimbursement represents the vehicle's average daily allowance (see table below) multiplied by the number of days the vehicle was in dealer inventory and not available for sale. This reimbursement is limited to the number of days from the date of the stop sale to the date that the remedy was made available. Note: If the vehicle was received by your dealership (KZX date) AFTER the stop sale date, you will use the KZX date instead of the stop sale date. For this Recall, the stop sale was initiated on 11/22/2023 and the remedy was made available on 02/27/2024, therefore, the number of days cannot exceed 92 days.

Vehicle	Average Daily Allowance
2021-2024 (JL) Jeep Wrangler	██████

Add the cost of the recall parts plus applicable dealer allowance to your claim.

NOTE: See the Warranty Administration Manual, Recall Claim Processing Section, for complete recall claim processing instructions.

PARTS INFORMATION

No parts are required for this campaign unless HV battery requires replacement.

Very few vehicles are expected to require HV battery replacement.

Part No.	Qty.	Part Name
68488244AA	1	400V Battery
68163849AB	1	Coolant
06512293AA	3	Bolt, Rear Seat

PARTS RETURN

Return instructions for the old battery are included in the container with the new battery. There is a ██████ core charge for this battery.

NOTE: Please read and follow the I-Sheet instructions that are included with the replacement battery for unpacking upon receipt and packing for return of removed battery information.

NOTE: If the battery return instructions are missing, a battery return I sheet can be downloaded from DealerCONNECT on the "Parts Tab" under the heading "Returns".

SPECIAL TOOLS

Required for all vehicles:

Number	Description
NPN	wiTECH MDP
NPN	Laptop Computer
NPN	wiTECH Software
10441	Cone, Safety
10442	Barriers, Safety
10452	Sign, Danger High Voltage
10443	Cards, Windshield and Dash Placement
NPN	Level 2 High Voltage Battery Charger

Only if battery replacement is necessary.

Number	Description
2035100082	Covers, HEV Battery Terminal
2035203080	Eyebolt, 10mm
2035200080	Lift Straps, HV Battery
BX50-CHR	Table, Bishamon Lift
126-1587	Meter, Fluke
NPN	HV Personal Protection Equipment

DEALER NOTIFICATION

To view this notification on DealerCONNECT, select “Global Recall System” on the Service tab, then click on the description of this notification.

OWNER NOTIFICATION / SERVICE SCHEDULING

All involved vehicle owners known to FCA are being notified of the service requirement by first class mail. They are requested to schedule appointments for this service with their dealers. A generic copy of the owner letter is attached.

VEHICLE LISTS, GLOBAL RECALL SYSTEM, VIP AND DEALER FOLLOW UP

All involved vehicles have been entered into the DealerCONNECT Global Recall System (GRS) and Vehicle Information Plus (VIP) for dealer inquiry as needed.

GRS provides involved dealers with an updated VIN list of their incomplete vehicles. The owner’s name, address and phone number are listed if known. Completed vehicles are removed from GRS within several days of repair claim submission.

To use this system, click on the “**Service**” tab and then click on “**Global Recall System**.” Your dealer’s VIN list for each recall displayed can be sorted by: those vehicles that were unsold at recall launch, those with a phone number, city, zip code, or VIN sequence.

Dealers must perform this repair on all unsold vehicles before retail delivery. Dealers should also use the VIN list to follow up with all owners to schedule appointments for this repair.

Recall VIN lists may contain confidential, restricted owner name and address information that was obtained from the Department of Motor Vehicles of various states. Use of this information is permitted for this recall only and is strictly prohibited from all other use.

ADDITIONAL INFORMATION

If you have any questions or need assistance in completing this action, please contact your Service and Parts District Manager.

Customer Services / Field Operations
 FCA US LLC.

SERVICE PROCEDURE

A. Pre-Check B9A Battery Integrity Procedure

NOTE: The wiTECH scan tool must be used to perform this Safety Recall. The wiTECH software is required to be at the latest release level before performing this procedure.

1. Install a 12-Volt battery charger. Do not allow the charger to time out. Set the battery charger timer (if so equipped) to maintain 12-Volt continuous charge.

NOTE: The vehicle MUST NOT be connected to a high voltage battery charger.

2. Connect the wiTECH MDP to the vehicle data link connector.

NOTE: Same wiTECH MDP MUST be used throughout the procedure.

3. Place the ignition in the “**RUN**” position.
4. Open the wiTECH 2.0 website.
5. Enter your “**User ID**” and “**Password**” and your “**Dealer Code**”, then select “**Sign In**” at the bottom of the screen. Click “**Accept**”.
6. From the “**Vehicle Selection**” screen, select the appropriate vehicle.

NOTE: Obtain a Vehicle Scan Report VSR and ECU details report. Both must be provided to the STAR Center for High Voltage Battery replacement authorization.

- a) Create and save a Vehicle Scan Report VSR and ECU details report before proceeding. Both pre and post scan reports **will be required** for submission.
 - b) From the left column in the analysis section, select “**Reports**”.
 - c) On the reports page, select “**Vehicle Scan Report**”.
 - d) Repeat to obtain ECU details report.
 - e) Select “**Printer Friendly**” then save file type as “**PDF**”. Name the file with the last eight digits of the VIN.
7. From the “**Action Items**” screen, select the “**Topology**” tab.
 8. Select “**BPCM**” icon.
 9. Select “**System Test**” tab.
 10. Select “**Pre-Check B9A Battery Integrity Procedure**” then follow the wiTECH screen instructions to complete the routine. At the conclusion of the routine, wiTECH will advise the next step.

B. BPCM Software Update

NOTE: The wiTECH scan tool must be used to perform this Safety Recall. The wiTECH software is required to be at the latest release level before performing this procedure.

NOTE: The BCPM, AHCP, HCP, IDCM, PCM, and TCM must all be updated to the latest available software at the conclusion of this repair procedure. Refer to all applicable published technical service bulletins for detailed repair procedures regarding updating the AHCP, HCP, IDCM, PCM, and TCM software.

CAUTION: BPCM must be updated first. Failure to update the AHCP, HCP, IDCM, PCM, and TCM module following an BCPM software update may result in vehicle malfunctions.

NOTE: It is normal for the high voltage charging lamp on the dash to flash like there is a charging system failure while performing software updates.

NOTE: If the BPCM reprogramming is aborted or interrupted during reprogramming, it must be restarted. The BPCM software must be at the latest software calibration level after completing this safety recall.

1. Install a 12-Volt battery charger. Do not allow the charger to time out during the flash process. Set the battery charger timer (if so equipped) to maintain 12-Volt continuous charge.

NOTE: The vehicle **MUST NOT** be connected to a high voltage battery charger during the flash process.

2. Connect the wiTECH MDP to the vehicle data link connector.

NOTE: Same wiTECH MDP **MUST** be used throughout the procedure.

3. Place the ignition in the **“RUN”** position.
4. Open the wiTECH 2.0 website.
5. Enter your **“User ID”** and **“Password”** and your **“Dealer Code”**, then select **“Sign In”** at the bottom of the screen. Click **“Accept”**.
6. From the **“Vehicle Selection”** screen, select the vehicle to be updated.
7. From the **“Action Items”** screen, select the **“Topology”** tab.
8. From the **“Topology”** tab, select the **“BPCM”** module icon.
9. From the **“Topology”** tab, select **“ALL DTCs”** then **“Clear All”**. If any fault code(s) are present, repair as directed in the service manual procedure. If there are no active fault code(s) proceed to next step.
10. Disable HV Battery Contactors using wiTECH - Go to the Misc Functions tab / Select Disable HV Battery Contactors / then follow the wiTECH prompts. Wait 5 minutes then use wiTECH to confirm that the contactors are open. If the contactors do not open turn the ignition on then off. Once successful a note will appear on the wiTECH screen indicating the contactors are open.

11. From the “**Action Items**” screen, select the “**All Flashes**” tab.
12. Select “**BPCM**” by clicking the arrow on the right side of the screen. Read the special flash instructions, then select “**OK**”. Continue with **Step 13**.
 - If “**BPCM**” is not displayed as one of the available flashes, the **BPCM** software is already at the current software level and does not require updating. Proceed to **Step 17**
13. From the “**Flash ECU Agreement**” page, agree to terms by “**Checking the Box**”.
14. Select “**Flash ECU**” and then follow the wiTECH screen instructions to complete the flash.
15. Once the software is confirmed to be at the latest available calibration level, select “**View DTCs**”.
16. Select the “**Clear All DTCs**” tab, then click “**Clear All DTCs**” and then select “**Close**”. It may be necessary to cycle the ignition to OFF then back to RUN to clear the codes.
17. The AHCP, HCP, IDCM, PCM, and TCM must be updated to the latest available software. Refer to all applicable published technical service bulletins for detailed repair procedures regarding updating the IDCM, PCM, and TCM software. Claim the Related LOPs for AHCP, HCP, IDCM, PCM, and TCM updates if software requires updating.
18. Enable HV Battery Contactors using wiTECH - Go to the Misc Functions tab / Select Enable HV Battery Contactors For Service / then follow the wiTECH prompts.
19. Place the ignition in the “**OFF**” position.
20. Remove the 12-volt battery charger from the vehicle.
21. Proceed to **Section C. High Voltage Battery Integrity Procedure**.

C. B9A Battery Integrity Procedure

NOTE: High Voltage Battery must be at or above 90% charge to begin the procedure.

NOTE: The wiTECH scan tool must be used to perform this procedure. The wiTECH software is required to be at the latest release level before performing this procedure.

NOTE: A Level 2 high voltage battery charger **MUST** be used during this procedure.

NOTE: The two 3-hour sleep cycles during this procedure are **CRITICAL** to allow the Battery Pack Diagnostic to run.

NOTE: To enable the diagnostic, the battery pack **MUST** be above -7C / -20F.

NOTE: If Ambient Temperatures are expected to be below -18C / -1F, the vehicle **MUST** be plugged into a Level 2 high voltage battery charger to warm the battery pack.

NOTE: At no time should the vehicle be driven to warm the battery pack.

NOTE: The vehicle **MUST** be parked **OUTSIDE** during this recall procedure.

This procedure will be completed in multiple stages as follows:

- Pre-Condition and DTC Check
- 3 Hour Sleep Cycle
- Vehicle Wake Up
- 3 Hour Sleep Cycle
- Final DTC Check

Each step of this procedure will be saved to the server and will enable the next steps if conditions are met.

Example: If you are instructed to charge for 3 hours, you will not be able to proceed until 3 hours have passed.

CAUTION: Vehicles involved in this recall should **NOT** be left connected to a charger after business hours.

PREPARE THE WORK AREA

- Assemble the six Cone, Safety 10441 and six **Barriers, Safety 10442** around the vehicle.
- Position the two Sign, **Danger High Voltage 10452** within the assembled safety cones and barriers.
- Place the four Cards, **Windshield and Dash Placement 10443** within the vehicle.
- Create and tape a **DO NOT DISTURB** sign on driver's door handle and near charge port.

Disable The Charging Schedule:

NOTE: It is important to disable the Charging Schedule on the display. Failure to disable the charging schedule may require restarting the procedure.

1. Select “Apps” then “Hybrid Electric” on the display (Figure 1).
2. Scroll through screens until locating the “Hybrid Electric” app. (Figures 1 and 2).
3. Select “Hybrid Electric” app (Figure 2).

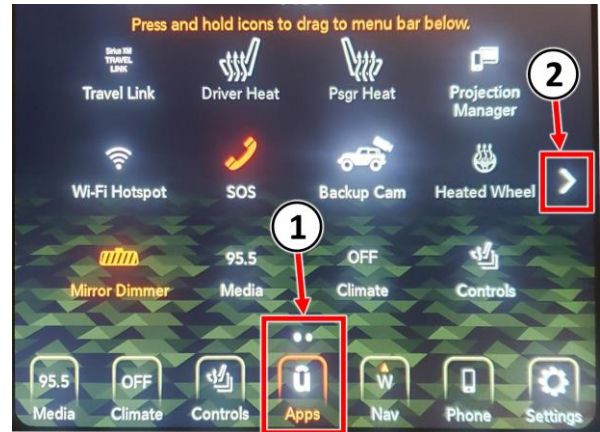

Figure 1 – Apps Display Screen

3. Select “Hybrid Electric” app (Figure 2).



Figure 2 – Apps Display Screen

4. Verify the “Check Mark” is NOT selected in the “Enable Schedule” box (Figure 3).

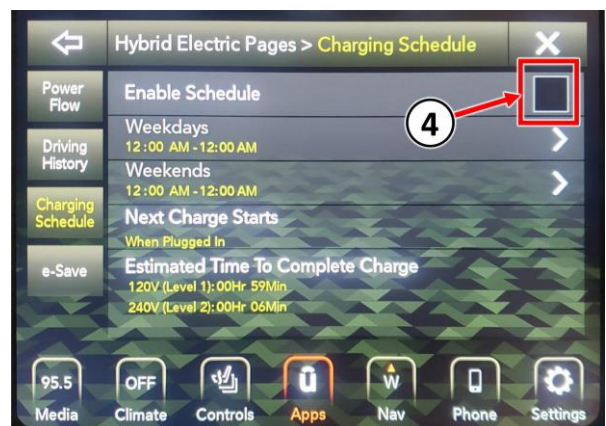

Figure 3 – Apps Display Screen

Battery Integrity Procedure START:

5. Connect the wiTECH MDP to the vehicle data link connector.
6. Open the wiTECH 2.0 website.
7. Enter your “**User id**” and “**Password**” and your “**Dealer Code**”, then select “**Sign In**” at the bottom of the screen. Click “**Accept**”.
8. From the “**Vehicle Selection**” screen, select the vehicle to be updated.
9. From the “**Action Items**” screen, select the “**Topology**” tab.
10. Select “**BPCM**” Icon.
11. Select “**System Test**” tab.
12. Select the “**B9A Battery Integrity Procedure**”.
13. Follow all screen prompts and instructions until test is completed.

NOTE: The BPCM Integrity Routine will take several hours to complete including two 3-hour sleep cycles. Any short cuts or deviation from the routine steps will result in having to restart the routine over again from the beginning.

14. You MUST reach the wiTECH routine screen advising either:
 - This procedure has already completed successfully on this vehicle.or
 - Replace Battery Pack.
15. The vehicle may now be returned to the customer provided High Voltage Battery does not require replacement.
 - If the wiTECH Routine indicates the High Voltage Battery requires replacement, proceed to **Section: D. High Voltage Battery Pack Replacement Procedure**.

NOTE: Obtain a Vehicle Scan Report VSR and ECU details report. Both must be provided to the STAR Center for High Voltage Battery replacement authorization.

- a) Create and save a Vehicle Scan Report VSR and ECU details report before proceeding. Both pre and post scan reports **will be required** for submission.
- b) From the left column in the analysis section, select “**Reports**”.
- c) On the reports page, select “**Vehicle Scan Report**”.
- d) Repeat to obtain ECU details report.
- e) Select “**Printer Friendly**” then save file type as “**PDF**”. Name the file with the last eight digits of the VIN.

D. High Voltage Battery Pack Replacement

Only individuals with high voltage training and repair qualifications should be allowed to handle, troubleshoot, or repair High Voltage or Hybrid components or systems.

Always wear safety glasses.

Review the **High Voltage Safety Procedures** available in DealerCONNECT > Service Library > under: 12 - Electrified Powertrain System / High Voltage Battery / Standard Procedure.

NOTE: Orange is the warning color used to identify high voltage parts. These warning labels are attached to the high-voltage battery pack.

WARNING: When performing any repairs that involve contact with high voltage components or systems, the technician performing repairs on the vehicle must verify that the system remains powered down during high voltage repairs.



- This must be done by removing the service disconnect or high voltage disabling device.
- The high voltage power down procedure must also be performed to ensure that the vehicle is properly powered down.
- The technician must know the whereabouts of the service disconnect or high voltage disabling device throughout the repair.
- The technician must ensure that no one reconnects the service disconnect or high voltage disabling device while service is being performed.
- The technician must recheck that the service disconnect or high voltage disabling device has not been reinstalled in cases where the vehicle was unattended.

WARNING: Failure to comply with all these warnings may result in personal injury including burn, shock, or fatal injury.

WARNING: Before performing any diagnostic or service procedure, you must thoroughly read and follow all applicable high voltage safety procedures. You must perform the high voltage power down procedures.

Loss of Isolation (LOI) must be performed before high voltage power up in cases where service has been performed on a high-voltage component or when diagnosing a LOI condition.

Be sure to use the proper safety equipment when working on any high voltage system or component. Failure to do so may result in serious or fatal injury.

Wait a minimum of two minutes after performing the high voltage battery disconnect procedure before attempting to access the high voltage system. Failure to do so may result in serious or fatal injury.

1. Using the scan tool, verify there are no stuck contactor DTCs active or stored. If DTCs are present, the high voltage system may not power down properly. Address the DTCs before continuing power down procedure.
2. Prepare the work area and familiarize yourself with all HIGH-VOLTAGE SAFETY PROCEDURES related to personal safety and vehicle safety associated with working on a Plug-In Hybrid Electric Vehicle (PHEV). Refer to 12 - Electrified Powertrain System/High Voltage Battery/Standard Procedure.
3. Inspect all orange high voltage cables, and high voltage components labeled with the high voltage symbol for physical damage. If damage is present, extra caution must be taken to avoid contact with unprotected high voltage. **Do not** insert probes, tools, objects or fluids into damaged high voltage cables or components.
4. Disconnect any charging equipment. Do not plug in the Electric Vehicle Supply Equipment (EVSE) recharge coupler when working on the vehicle.
5. Turn the ignition to **OFF** by pressing the keyless go button (1). Move keys away from the car a minimum of 20 feet (Figure 4).

NOTE: If the READY indicator is NOT illuminated in instrument cluster, the vehicle is already shut off. DO NOT push the start/stop button as the vehicle may start.

6. **Wait five minutes** to allow the high voltage system to shut down without setting a fault code.



Figure 4 – Keyless Go Button

7. Use of an insulation tester such as the Fluke Meter, Multi 126-1587 is recommended for PHEV circuit testing. Perform the multi-meter functionality tests per the manufacturer's directions. If at any point during the procedure, the multi-meter settings are changed, or the probes are repositioned in the meter, verification with a known good power source must be repeated (Figure 5).

NOTE:

- Use known good test leads.
- Verify the multi-meter leads are rated "CAT III 1,000V". This should be printed on the multi-meter leads.
- Install the multi-meter leads in the BLACK and RED sockets on the right side of the Fluke 1587 (VΩ (RED) and COM (BLACK)).
- Test the multi-meter operation by measuring the voltage across the 12-volt battery.
- Switch the FLUKE 1587 to the DC Volts selection and press the RANGE button until the 1000V range is selected - just one digit (a zero) is displayed.



Figure 5 – Multi Meter

8. The high voltage service test points access cover is located on the battery pack, under the drivers side rear seat cushion.
9. Remove the Torx screws (2) from the high voltage service test points access cover (1) (Figure 6).

NOTE: Lift the cover straight up to avoid bending or damaging the HVIL pin on the cover that is used to engage the internal HVIL switch.

10. Carefully remove the test points access cover and set in a protected location so that the cover plate alignment and HVIL pins (3) are not damaged (Figure 6).

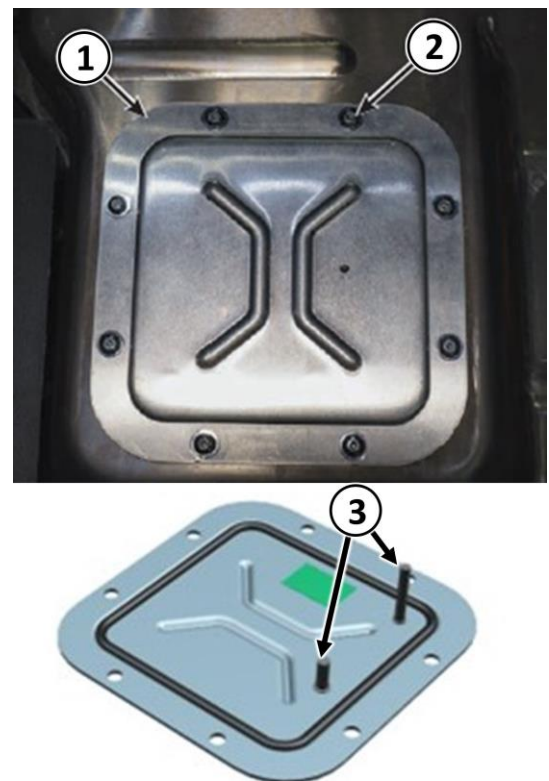

Figure 6 – Test Point Access Cover

SAFETY RECALL

NORTH AMERICA

High Voltage Battery



Reference: B9A / NHTSA 23V-787

FCA US LLC

NOTE: A pair of certified PPE gloves should be worn when working around high voltage components. Wear the gloves where needed during the next steps until verifying that the HV battery is powered down. Refer to the High Voltage Safety Procedures for the proper PPE gloves (Refer the detailed procedures available in DealerCONNECT > Service Library > under: 12 - Electrified Powertrain System/High Voltage Battery/Standard Procedure).

11. Removal of the test points access cover will affect the following:

- Disables the High Voltage Battery System by disengaging the internal High Voltage Interlock (HVIL) pin from the switch.
- Provides access to the high voltage positive and high voltage negative test points.

NOTE: The test points are connected to a sense circuit connected through large resistors inside the high voltage battery to the high voltage bus cables after the contactors. These circuits are safe even when high voltage is present on the circuits due to the large resistors reducing these circuits to milliamperes.

- Provides access to the fuse cover screw.
- Allows access to a service lockout loop.

12. Install a lockout-tagout padlock to the service lockout loop (4) to prevent test points access cover installation and re-engaging HVIL pin (Figure 7).

13. Disconnect the IBS wire harness connector. Remove and isolate the battery negative cable using Covers, HEV Battery Terminal 2035100082 (Figure 8).

14. Using a multi-meter connected to chassis ground, check for voltage at the PDC fused B+ terminal to verify the low voltage system is powered down.

NOTE: On some vehicles a small amount of voltage may be present (typically less than approximately 1.0 volts) due to capacitors in some modules still having voltage stored.

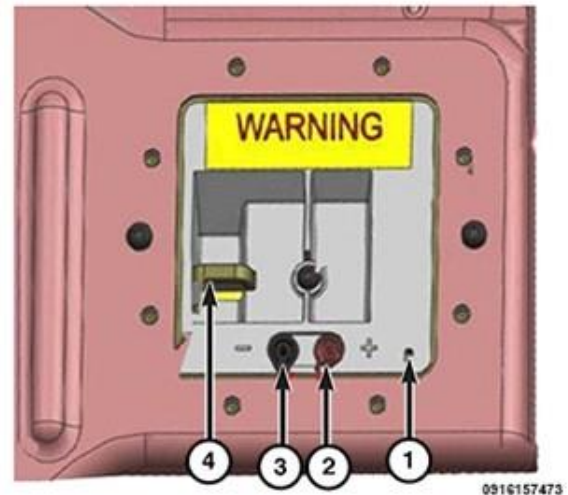

Figure 7 – HV Battery Test Points

- 1 - Internal HVIL Switch
- 2 - High Voltage (+) Test Port
- 3 - High Voltage (-) Test Port
- 4 - Service Lockout Loop

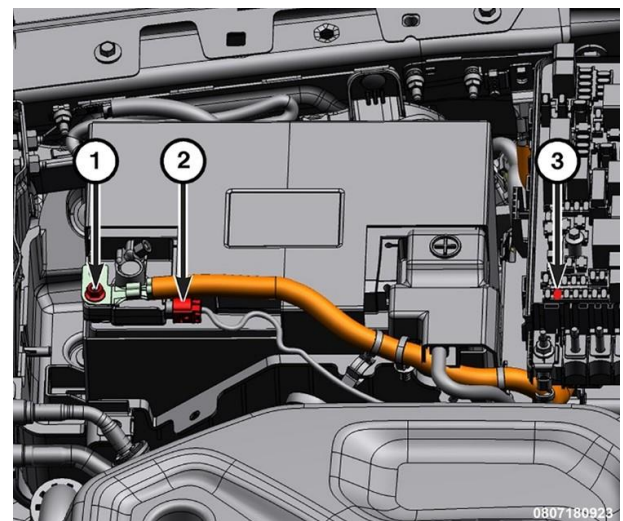

Figure 8 – 12-Volt Battery

- 1 - Battery Negative Cable Nut
- 2 - IBS Wire Harness Connector

Strictly respect STELLANTIS Group safety, cleanliness, and environmental instructions for any vehicle service.

Document exclusively reserved for dealer information. Internal distribution to be ensured by dealer.

Reproduction forbidden without the written agreement of STELLANTIS Group. (C) 2024 STELLANTIS Group. All Rights Reserved

(tdb)

15. Using the Fluke multi-meter, measure the voltage at the high voltage positive and high voltage negative test points as follows (Figure 9):
- Measure for voltage between the positive and negative high voltage test points.
 - Measure for voltage between positive test point and chassis ground.
 - Measure for voltage between negative test point and chassis ground.



Figure 9 – HV Battery Test Points

16. The voltage reading should be near 0 volts for each measurement. (Some residual voltage may be present, up to 2.0 volts may be normal).
- If the voltage measured is below 2 volts, it is safe to work on the high voltage components with the exception of the high voltage battery internal components.
 - If the voltage is greater than 50 volts, **an internal condition exists within the high voltage battery such as stuck contactors, that are preventing it from being powered down. This should be accompanied by contactor stuck DTCs. Do not attempt to carry out testing on any of the vehicle's high voltage components or wiring. The HV Battery Pack requires replacement. Reference the HV BATTERY SERVICING WITH WELDED CONTACTOR(S) procedure at the top of the HV PHEV BATTERY REMOVAL AND INSTALLATION procedure for safely removing a high voltage battery that will not power down (Refer to 12 - Electrified Powertrain System/Electric Powertrain Control/MODULES, High Voltage System/Removal and Installation).**
 - If the voltage is between 2.0 volts and 50 volts, the HV system is safe to work on, however there is a problem that should be diagnosed. Disconnect each of the following HV modules one at a time and check the voltage at the test points. If the voltage drops to 2.0 volts or less, the faulted module has been found. Reconnect each module before continuing to the next.
 - Integrated Dual Charger Module (IDCM)
 - Electronic A/C Compressor (EAC)
 - Battery Coolant Heater
 - HV Coolant Heater
 - Power Inverter Module (PIM)

NOTE: Observe the following precautions when handling the HV battery pack:

- **DO NOT** touch the high voltage terminals.
- Always use the battery pack four lift points when moving the battery pack.
- Keep the battery pack in an upright position.
- Store in a clean and dry environment.
- Store at a temperature of 10-30°C (50-86°F) with relative humidity between 30-70%.
- Always store at a State Of Charge (SOC) of around 30%.
- Always store on an electrically nonconducting (insulated) material.
- Store with spatial gap of at least 50 cm (20 in.).
- **DO NOT** store the battery pack near any environmental condition involving liquid, heat, strong magnetic field, electricity or that can generate heat (for example: transformers).

NOTE: The HV battery pack weighs 167 kg (368 lb.).

NOTE: If the High Voltage (HV) battery return instructions are missing, a battery return I sheet can be downloaded from DealerCONNECT on the “Parts Tab” under the heading “Returns”.

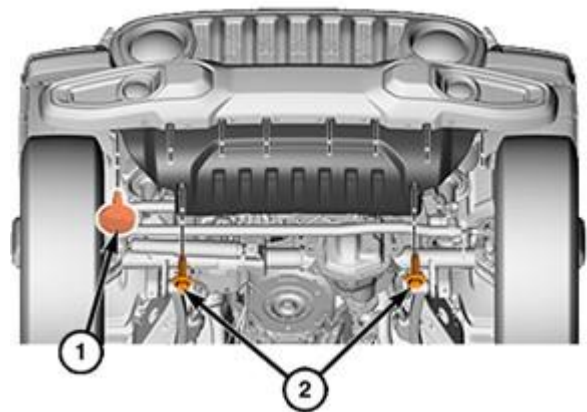

Figure 10 – Air Dam Fasteners

17. Loosen the cap on the high voltage cooling reservoir.

18. Raise and support the vehicle.

19. Remove the eight push pin fasteners from the front air dam (1) (Figure 10).

20. Remove the bolts (2) (Figure 10).

21. Remove the air dam (1) (Figure 11).

22. Remove the support and lower the vehicle.

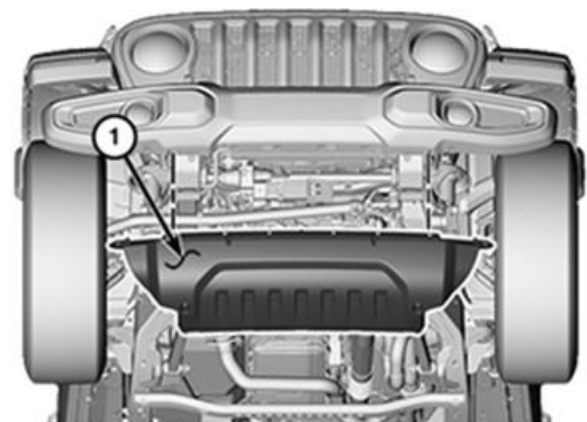

Figure 11 – Air Dam

23. Disconnect the vacuum boost hose quick coupling (1) from the air cleaner body cover (Figure 12).

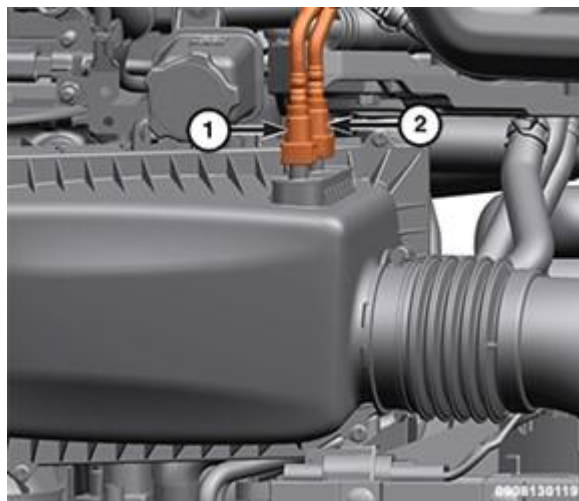

Figure 12 – Air Cleaner Cover

- Push in and hold both sides of the grey release (1) on the quick coupling (Figure 13).
- Pull the quick coupling away from air cleaner body cover.



Figure 13 – Hose Connections

24. Disconnect the fuel vapor purge hose quick coupling (2) from the air cleaner body cover (Figure 12).
- Do not press on the green anti-tampering feature (1) (Figure 14).
 - Push in and hold only the side of the release (2) with the green anti-tampering feature and pull the quick coupling away from air cleaner body cover.



Figure 14 – Hose Connections

25. Loosen the clean air hose band clamp (2) (Figure 15).
26. Remove the bolt (3) (Figure 15).
27. Disengaging the air cleaner body (1) from the two lower rubber grommets and from the clean air hose (Figure 15).

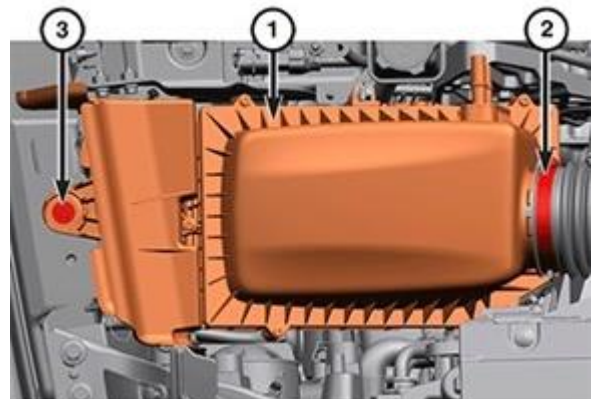

Figure 15 – Air Cleaner

28. Raise and support the vehicle.
29. Position a drain pan under the coolant hoses (Figure 16).
30. Remove the coolant hoses from the coolant line and drain the power electronics cooling system (Figure 16).
31. Once the system is completely drained, reinstall the coolant hose to the coolant line (Figure 16).
32. Remove the fasteners (1) and the skid plate (2) from the vehicle (Figure 17).

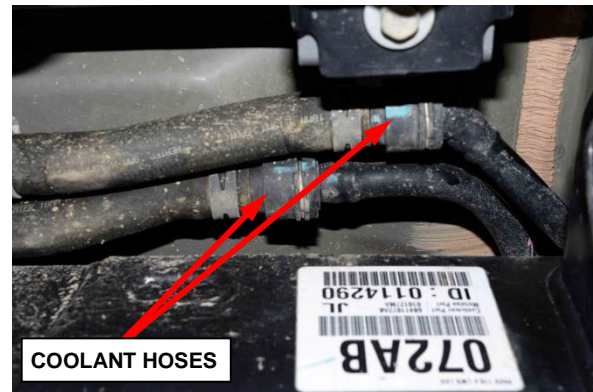

Figure 16 – Coolant Hoses

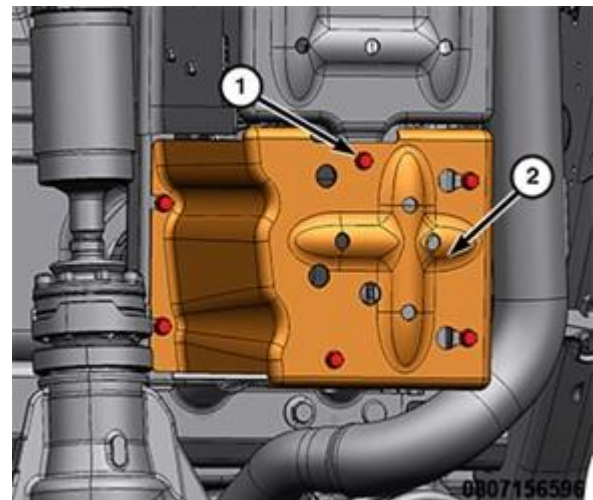

Figure 17 – Skid Plate

SAFETY RECALL
NORTH AMERICA
High Voltage Battery



Reference: B9A / NHTSA 23V-787

FCA US LLC

- 33. Disconnect the HV wire harness connectors (1) and (2) from the HV battery (Figure 18).

- 34. Cap the HV cables using Covers, HEV Battery Terminal 2035100082.

NOTE: A Plug-in Hybrid Electric Vehicle (PHEV) HV Battery Cover/Plug Kit is also available from Mopar® Parts.

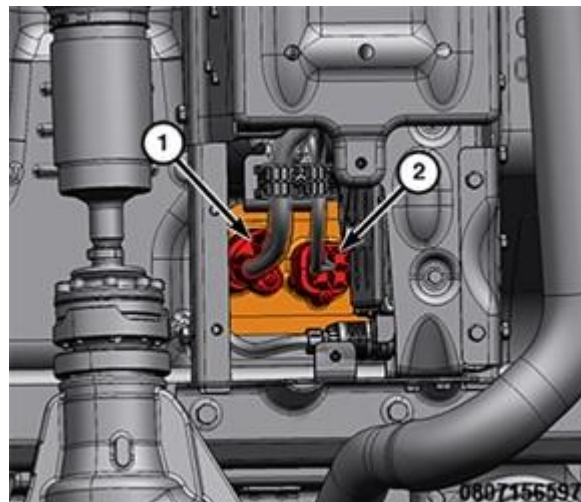

Figure 18 – HV Battery Wiring Connectors

- 35. Remove the support and lower the vehicle.

- 36. Using a trim stick, release and remove the B-pillar trim cover (1) (Figure 19).



Figure 19 – B-pillar Trim Cover

37. Disconnect the wire harness connector (2) and release the door tether from the support bracket (1) (Figure 20).



Figure 20 – Harness to Support Bracket

38. Remove the bolt (2) securing the door check (1) (Figure 21).

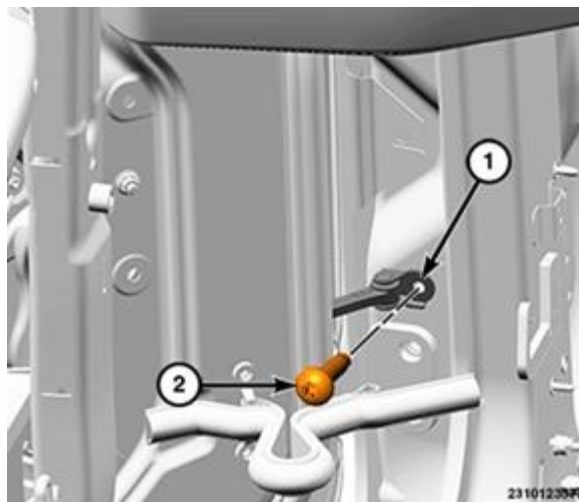

Figure 21 – Door Check Bolt

- 39. Remove the nuts (3) and lift the door up off hinges (1) and remove (Figure 22).
- 40. Raise the rear seat cushion.

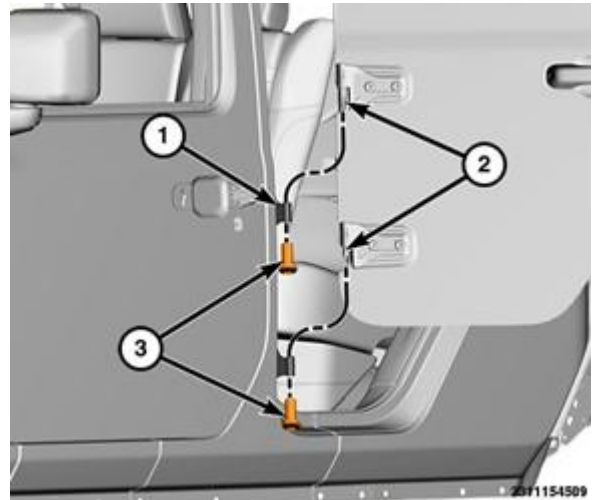

Figure 22 – Hinge Pin Nuts

- 41. Remove the fasteners (1) from the side high voltage battery trim panels (2) (Figure 23).
- 42. Using a trim stick or equivalent, remove the high voltage trim panel upward to release the retainers and remove the trim panel. Repeat for the passenger side.
- 43. Lower the rear seat cushion.

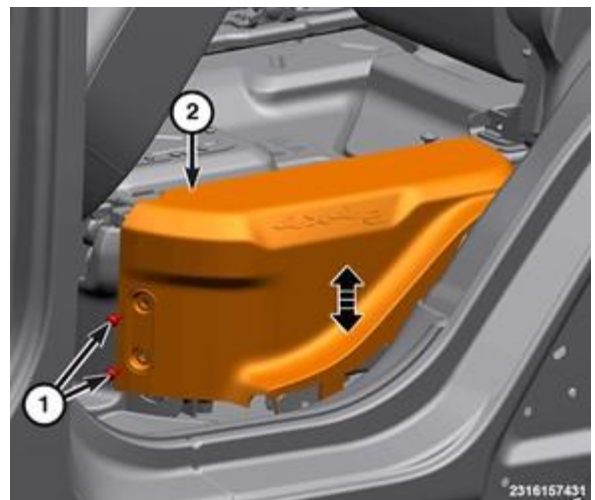

Figure 23 – HV Battery Side Trim

SAFETY RECALL
NORTH AMERICA
High Voltage Battery



Reference: B9A / NHTSA 23V-787

FCA US LLC

- 44. Using a trim stick or equivalent, release the retainers from the front high voltage battery closeout and remove from vehicle (Figure 24).

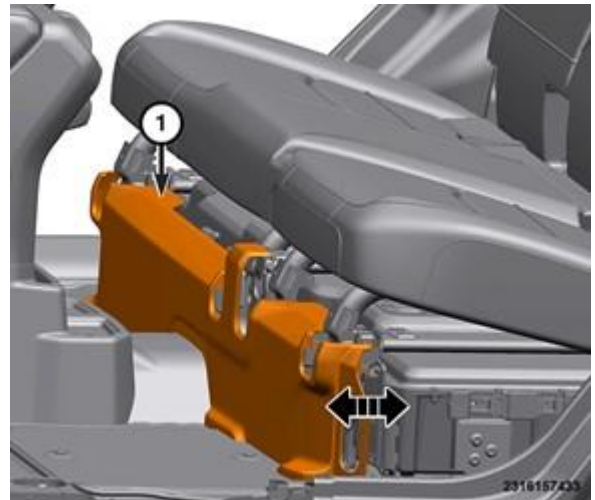

Figure 24 – HV Battery Front Trim

- 45. Remove the rear seat to load floor gap hider (Figure 25).



Figure 25 – Gap Hider

- 46. Disconnect the wire harness connectors, if equipped (4) (Figure 26).
- 47. Remove the nut for the center seat belt anchor (6). Remove the seat belts from the floor stud (Figure 26).
- 48. Remove the rear seat fasteners (2) at the rear of the seat (Figure 26).

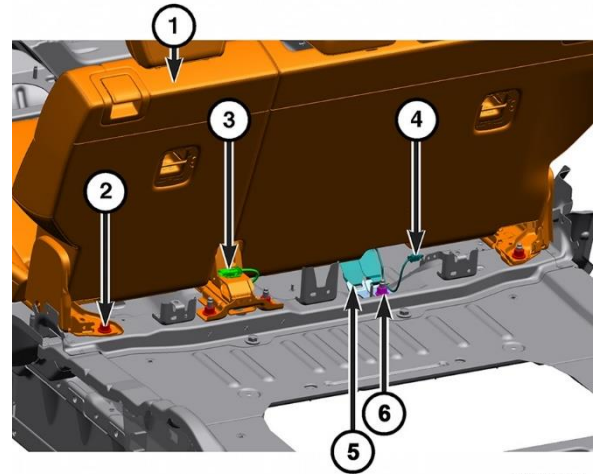

2319177336

Figure 26 – Rear Seat Components

- | | |
|----------------------------|---------------------------------|
| 1 - Rear Seat | 4 - Wire Harness Connector |
| 2 - Rear Seat Nuts | 5 - Seat Belts |
| 3 - Wire Harness Connector | 6 - Center Seat Belt Anchor nut |

- 49. Disconnect the wire harness connectors (2), if equipped (Figure 27).
- 50. Remove the bolts (1) at the front of the rear seat (Figure 27).

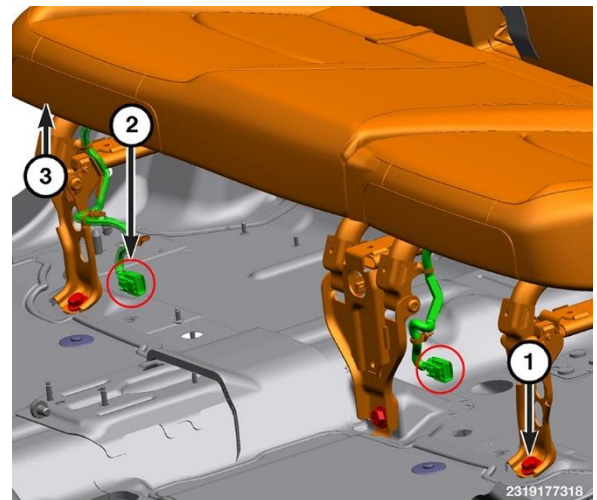

2319177318

Figure 27 – Rear Seat Components

- 1 - Rear Seat Bolts
- 2 - Wire Harness Connectors
- 3 - Rear Seat

51. Remove silencer pad (Figure 28).
52. Remove the seat from the vehicle.

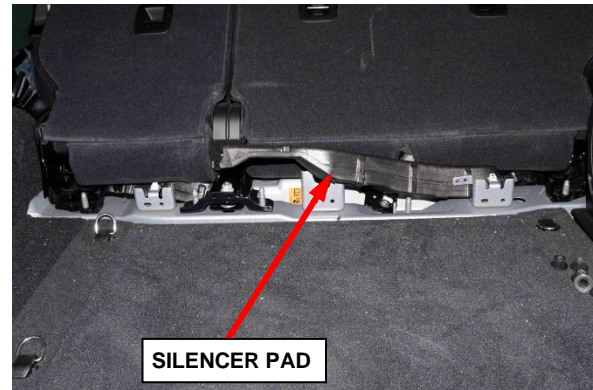

Figure 28 – Silencer Pad

53. Remove the fastener (1) and the chassis ground cable from the HV battery (2) (Figure 29).

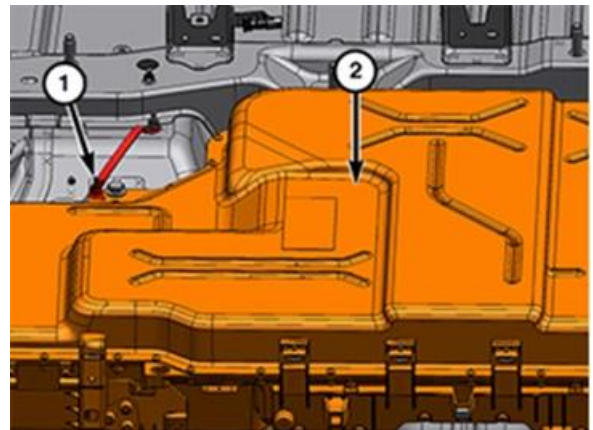

Figure 29 – HV Battery Fastener and Ground Cable

54. Disconnect the HV wire harness connectors (1) (Figure 30).

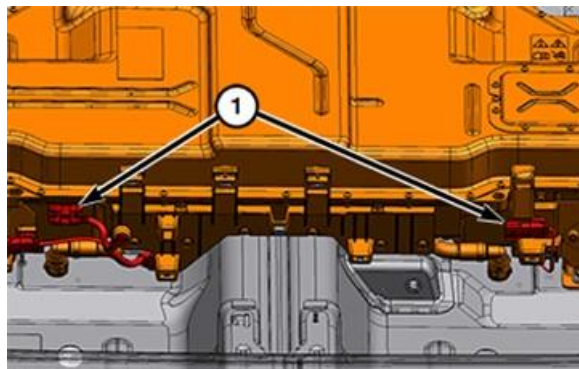

Figure 30 – HV Wire Harness Connectors

NOTE: Use an absorbent pad to collect any coolant that may leak from the battery into the interior of the vehicle.

55. Disconnect and plug the HV battery coolant line connectors (1) (Figure 31).

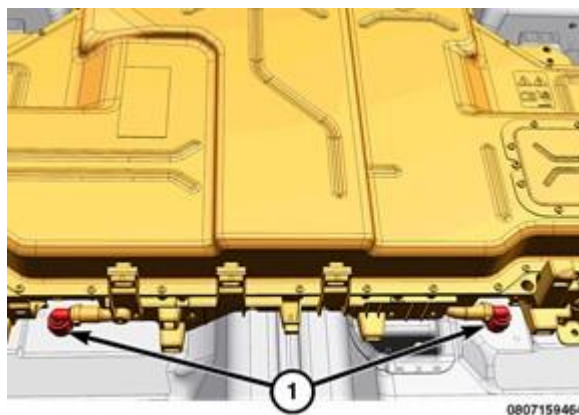

Figure 31 – HV Battery Coolant Connectors

NOTE: The HV battery pack weighs 167 kg (368 lb.).

- 56. Remove the bolts (1) securing the HV battery to the vehicle (Figure 32).

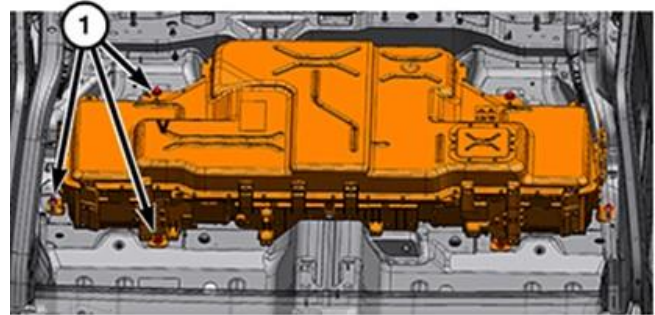

Figure 32 – HV Battery Bolts

- 57. Install two Eyebolt, 10mm 2035203080 with the nuts to the front support mounting holes (1) (Figure 33).

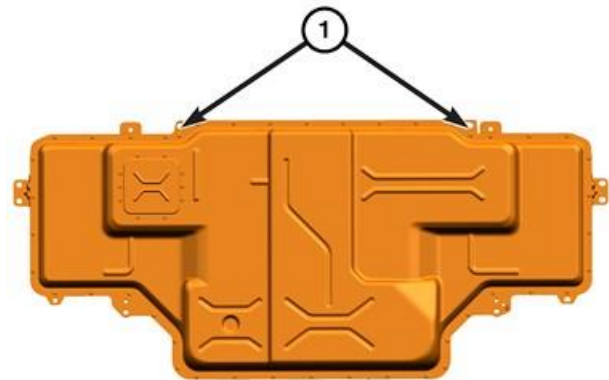

Figure 33 – Support Mounting Holes

- 58. Thread the other two Eyebolt, 10mm 2035203080 (1) into the threaded holes next to the HV battery pack mounting bolt holes (2) on the rear side of the HV battery pack (Figure 34).

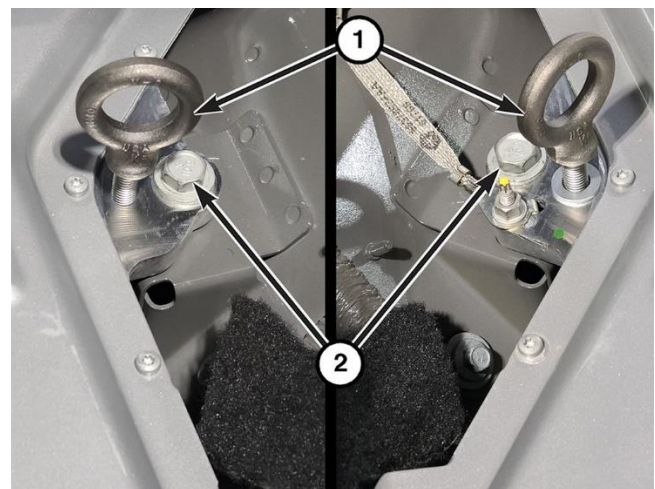

Figure 34 – Eyebolt Installation

59. Connect the Lift Straps, HV Battery 2035200080 to the eyebolts and the lifting device. Adjust the straps so that the battery will be level during lifting as shown in the picture (Figure 35).

60. Remove the HV battery pack from the vehicle.



Figure 35 – Lift Straps

NOTE: When the HV battery pack is being replaced:

- Refer to the information supplied with the **NEW** battery.
- **All coolant must be removed from the battery. Use a shop air supply hose connected to the battery coolant inlet port. Adjust the air pressure regulator to not exceed 100 kPa (15 psi) and force the coolant from the battery coolant outlet port.**
- **All coolant ports and electrical connections must be capped.**
- **Place the HV battery pack in the shipping container or in a suitable storage location properly supported to prevent damage to the underside of the battery.**

61. Attach the Eyebolt, 10mm 2035203080 to the new HV battery pack in the same locations that were used for the removal. Connect the Lift Straps, HV Battery 2035200080 on the front and rear eyelets.
62. Secure the HV battery pack to the lifting device.
63. Install the HV battery pack in the vehicle making sure that the mounting holes align with the bolt holes in the body.
64. Remove the lifting strap and eyebolts.
65. Install the HV battery pack bolts (1) and tighten to (Figure 32):
- High Voltage Battery to Chassis M10 Bolts tighten to 45N·m (33 ft. lbs.).
 - High Voltage Battery to Chassis M8 Bolts tighten to 21N·m (15 ft. lbs.).
66. Install the chassis ground cable to the HV battery ground stud (1) and tighten to 9N·m (80 in. lbs.) (Figure 29).

67. Connect the HV battery coolant line connectors (1) (Figure 31).
 68. Connect the three HV wire harness connectors (1) (Figure 30).
 69. Install the silencer pad (Figure 28).
 70. Install the rear seat to the vehicle.
 71. Install the bolts at the front of the rear seat and tighten to 70N·m (52 ft. lbs.).
 72. Connect the wire harness connectors, if equipped (Figures 26 and 27).
 73. Install the rear seat fasteners at the rear of the seat and tighten to 70N·m (52 ft. lbs.).
 74. Install the seat belts from the floor stud.
 75. Install the nut for the center seat belt anchor and tighten to 70N·m (52 ft. lbs.).
 76. Raise the rear seat cushion.
 77. Install the rear seat to load floor gap hider (Figure 25).
 78. Align and install the retainers from the front high voltage battery closeout to the vehicle (Figure 24).
 79. Install the high voltage trim panel and press downward to seat the retainers (Figure 23).
 80. Install the fasteners to the side high voltage battery trim panels and tighten securely.
 81. Lower the rear seat cushion.
 82. Set the door into place on the hinges and install the door hinge pivot nuts. Tighten the nuts to 6N·m (53 in. lbs.) (Figure 22).
 83. Install the door check strap bolt securing the door check and tighten to 9N·m (80 in. lbs.) (Figure 21).
 84. Connect the wire harness connector and secure the door tether to the support bracket (Figure 20).
 85. Align and install the B-pillar trim cover (Figure 19).
 86. Raise and support the vehicle.
- NOTE: When connecting the High Voltage connection verify that the connectors are clean and seated properly.**
87. Remove the battery port covers and transfer them to the old battery. Connect the HV wire harness connectors (1) and (2) to the HV battery and tighten to 9N·m (80 in. lbs.) (Figure 18).
 88. Install the battery skid plate (2) and tighten the fasteners (1) to 25N·m (18 ft. lbs.)
 89. Remove the support and lower vehicle.

WARNING: ANTIFREEZE COOLANT IS HARMFUL IF SWALLOWED OR INHALED. IF SWALLOWED, DRINK TWO GLASSES OF WATER AND INDUCE VOMITING. IF INHALED, MOVE TO FRESH AIR

AREA. SEEK MEDICAL ATTENTION IMMEDIATELY. DO NOT STORE IN OPEN OR UNMARKED CONTAINERS. WASH SKIN AND CLOTHING THOROUGHLY AFTER COMING IN CONTACT WITH ETHYLENE GLYCOL. KEEP OUT OF REACH OF CHILDREN. DISPOSE OF GLYCOL BASED COOLANT PROPERLY. CONTACT YOUR DEALER OR GOVERNMENT AGENCY FOR LOCATION OF COLLECTION CENTER IN YOUR AREA. DO NOT OPEN A COOLING SYSTEM WHEN THE ENGINE IS AT OPERATING TEMPERATURE OR HOT UNDER PRESSURE; PERSONAL INJURY CAN RESULT. AVOID RADIATOR COOLING FAN AND OTHER MOVING COMPONENTS WHEN ENGINE COMPARTMENT RELATED SERVICE IS PERFORMED; PERSONAL INJURY CAN RESULT.

WARNING: WEAR APPROPRIATE EYE AND HAND PROTECTION WHEN PERFORMING THIS PROCEDURE.

90. Fill the battery cooling system.

NOTE: Fill the High Voltage (HV) battery cooling system with the recommended MOPAR Antifreeze Coolant (Refer to 04 - Vehicle Quick Reference/Capacities and Recommended Fluids/Specifications in Service Library).

91. Power up the HV battery system.

NOTE: When performing any repairs that involve contact with high voltage components or systems, the technician performing repairs on the vehicle must verify that the system remains powered down during high voltage repairs.

- This must be done by removing the test points access cover.
- The high voltage power down procedure must also be performed to ensure that the vehicle is properly powered down.
- The technician must know the whereabouts of the test points access cover throughout the repair.
- The technician must ensure that no one reinstalls the test points access cover while service is being performed.
- The technician must recheck that the test points access cover has not been reinstalled in cases where the vehicle was unattended.

92. Use of an insulation tester such as the Fluke Meter, Multi 126-1587 is recommended for Plug-In Hybrid Electric Vehicle (PHEV) circuit testing. Perform the multi-meter functionality tests per the manufacturer's directions. Verify the multi-meter is operating correctly by measuring voltage from a known good power source, such as the vehicle's 12-volt battery. If at any point during the procedure, the multi-meter settings are changed, or the probes are repositioned in the meter, verification with a known good power source must be repeated.

93. Remove the M6 Torx screws from the high voltage service test points access cover (Figure 36).
94. Carefully remove the test points access cover and set in a protected location such that the cover plate alignment and HVIL pins are not damaged (Figure 36).

NOTE: Lift the cover straight up to avoid bending or damaging the pin on the cover that is used to engage the HVIL switch.

NOTE: Always observe these precautions prior to taking an isolation resistance measurement:

- Have known good test leads
- Set the test voltage to 500 Volts
- Always wear safety glasses

95. Using the Meter, Multi 126-1587 measure and record the isolation resistance between the high voltage positive test point and chassis ground (Figure 37).

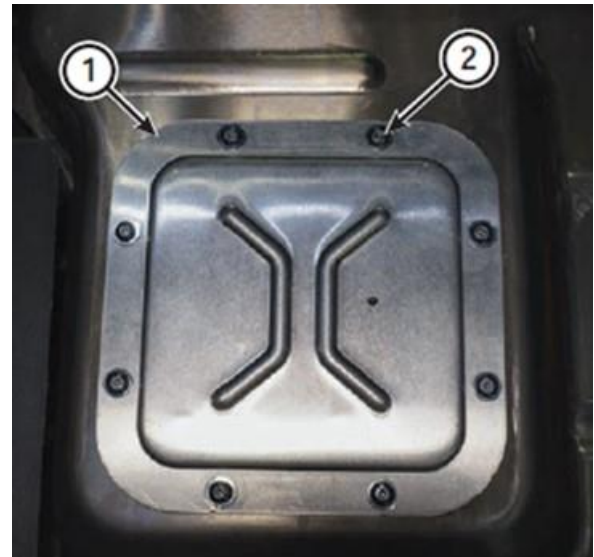

Figure 36 – Test Point Access Cover



Figure 37 – Measure and Record Isolation Resistance Between HV Positive Test Point and Chassis Ground

96. Using the Meter, Multi 126-1587 measure and record the isolation resistance between the high voltage negative test point and chassis ground (Figure 38).

97. Isolation resistance should be 2.3 Mohms (+/- .2). If the measured isolation resistance is outside of this range, a loss of isolation condition exists within the high voltage circuitry. **Do not continue the High Voltage Power Up procedure until the condition causing the loss of isolation is corrected.**



Figure 38 – Measure and Record Isolation Resistance Between HV Negative Test Point and Chassis Ground

98. If required, remove the lockout-tagout padlock from the service lockout loop (1) (Figure 39).



Figure 39 – Service Lockout Loop

99. Install the test points access cover (1) to the battery pack and securely tighten the eight M6 Torx screws (2), identified with blue circles (Figure 36).
100. Remove the cover, connect the negative battery cable to the IBS and tighten the fastener (1) to 10N·m (7 ft. lbs.) (Figure 40).
101. Install the F09 (5 amp) IDCM fuse (3) in the Power Distribution Center (PDC) (Figure 40).
102. Connect the IBS harness connector (2) (Figure 40).
103. Using the scan tool, delete any DTCs that may have set due to the IDCM fuse being removed. Turn the key OFF and wait 2 minutes,
104. Use the scan tool and flash program the BPCM with the latest software.
105. Use the scan tool and perform the “Enable Contactor for Service” procedure in BPCM.

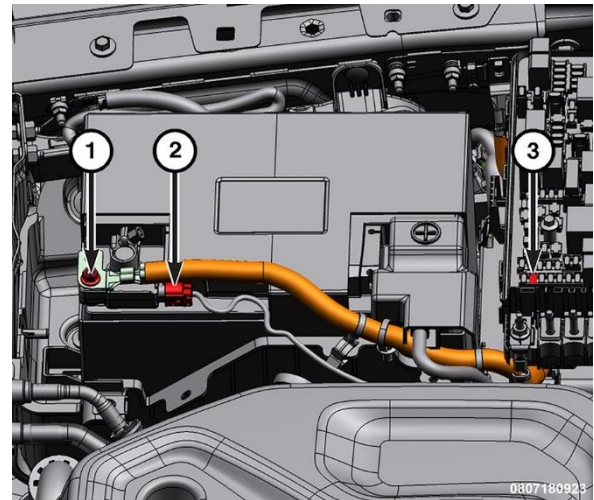

Figure 40 – Negative Battery Cable, Fuse F09 and IBS Connector

- NOTE: If these procedures are not performed, the vehicle will not start. The high voltage battery pack is shipped with the contactors locked in the open position for safety concerns. Until these routines are performed, the battery pack contactors will not close resulting in a no start condition.**
106. Close the hood, press the START button and verify that the Hybrid Status Indicator is green and no warnings are displayed.

FILL AND BLEED USING THE SCAN TOOL (PREFERRED)

- a) Fill the HV battery pressurized coolant bottle to the max level.
- b) Cycle the ignition to the on position.
- c) With the scan tool, run the “Coolant Fill Procedure” routine in the Hybrid Control Processor (HCP). This should run all of the coolant pumps in all cooling systems.
- d) Continue adding coolant to the HV battery pressurized coolant bottle maintaining the coolant at the max level.
- e) When no more coolant is needed the system is filled and bled. The routine may time out before the system is full and take multiple cycles to bleed all of the air from the system.
- f) Stop the scan tool actuation. Fill the bottle slightly above the fill line in case of any air trapped in the system.

FILL AND BLEED WITHOUT THE SCAN TOOL

- a) Fill the HV battery pressurized coolant bottle to the max level.
- b) Cycle the key to the on position to power the battery coolant pump in order to fill and bleed the HV cooling system.
- c) Cycle the key to the off position after the pump times out and stops running.
- d) Fill the HV battery pressurized coolant bottle to the max level.
- e) Repeat the fill procedure until the proper coolant level is achieved. Fill the bottle slightly above the fill line in case of any air trapped in the system.

107. Return the vehicle to the customer or inventory.

This notice applies to your vehicle,

[Model Year and Model]

VIN XXXXXXXXXXXXXXXXXXXX

B9A/NHTSA 23V-787

LOGO

VEHICLE PICTURE

YOUR SCHEDULING OPTIONS

- 1. RECOMMENDED OPTION**
Call your authorized Chrysler / Dodge / Jeep® / RAM Dealership.
- 2. Call the FCA Recall Assistance Center at 1-800-853-1403.** An agent can confirm part availability and help schedule an appointment.
- 3. Visit recalls.mopar.com, scan the QR code below, or download the Mopar Owner's Companion App.**

QR Code

Get access to recall notifications, locate your nearest dealer, and more through this website or Mopar Owner's Companion App. You will be asked to provide your Vehicle Identification Number (VIN) to protect and verify your identity. The last eight characters of your VIN are provided above.

DEALERSHIP INSTRUCTIONS

Please reference Safety Recall B9A.

IMPORTANT SAFETY RECALL

High Voltage Battery

Dear [Name],

This notice is sent to you in accordance with the National Traffic and Motor Vehicle Safety Act.

FCA US LLC has decided that a defect, which relates to motor vehicle safety, exists in certain [2021-2023 model year (JL) Jeep® Wrangler] Plug-In Hybrid Electric Vehicles (PHEVs).

It is extremely important to take steps now to repair your vehicle to ensure the safety of you and your passengers.

WHY DOES MY VEHICLE NEED REPAIRS?

The High Voltage (HV) battery on your vehicle ^[1] may fail internally. The defect has not been identified and the root cause is still being investigated. An internally failed HV battery could lead to a vehicle fire with the ignition on or off. **A vehicle fire can result in increased risk of occupant injury and/or injury to persons outside the vehicle, as well as property damage.**

Customers are advised to refrain from recharging these vehicles and not to park them inside of buildings or structures, or near other vehicles until the vehicle has the final repair completed.

HOW DO I RESOLVE THIS IMPORTANT SAFETY ISSUE?

FCA US will repair your vehicle ^[2] free of charge (parts and labor). To do this, your dealer will update the HV battery pack software and if a DTC sets, the HV battery pack will be replaced. The estimated repair time is **1.5 to 2 days**. In addition, your dealer will require your vehicle for proper check-in, preparation, and check-out during your visit, which may require more time. Your time is important to us, so we recommend that you schedule a service appointment to minimize your inconvenience. Please bring this letter with you to your dealership.

**TO SCHEDULE YOUR FREE REPAIR,
CALL YOUR CHRYSLER, DODGE, JEEP OR RAM DEALER TODAY**

WHAT IF I ALREADY PAID TO HAVE THIS REPAIR COMPLETED?

If you have already experienced this specific condition and have paid to have it repaired, you may visit www.fcarecallreimbursement.com to submit your reimbursement request online. ^[3] Once we receive and verify the required documents, reimbursement will be sent to you within 60 days. If you have had previous repairs performed and/or already received reimbursement, you may still need to have the recall repair performed.

We apologize for any inconvenience, but are sincerely concerned about your safety. Thank you for your attention to this important matter.

Customer Assistance/Field Operations
FCA US LLC



Mr. Mrs. Customer
1234 Main Street
Hometown, MI 48371

[1] If you no longer own this vehicle, please help us update our records. Call the FCA Recall Assistance Center at 1-800-853-1403 to update your information.

[2] If your dealer fails or is unable to remedy this defect without charge and within a reasonable time, you may submit a written complaint to the Administrator, National Highway Traffic Safety Administration, 1200 New Jersey Ave., S.E., Washington, DC 20590, or you can call the toll-free Vehicle Safety Hotline at 1-888-327-4236 (TTY 1-800-424-9153), or go to safercar.gov.

[3] You can also mail in your original receipts and proof of payment to the following address for reimbursement consideration: FCA Customer Assistance, P.O. Box 21-8004, Auburn Hills, MI 48321-8007, Attention: Recall Reimbursement.

Note to lessors receiving this recall notice: Federal regulation requires that you forward this recall notice to the lessee within 10 days.