

March 4, 2024

Version 3

Safety Recall: 2023–24 Accord Front Seat Belt Pretensioner InspectionSupersedes 23-098, dated November 29, 2023, to revise the information highlighted in **yellow**.**AFFECTED VEHICLES**

Year	Model	Trim Level	VIN Range
2023–24	Accord	ALL	Check the VIN status for eligibility.

REVISION SUMMARY

- Under **INSPECTION PROCEDURE, STEP 1** image updated.
- Under **TOOLS INFORMATION**, information was added.

BACKGROUND

During manufacturing, some front seat belt pretensioners may have been assembled without a rivet securing the quick connector and wire plate, resulting in front seat belts not functioning as designed, increasing the risk of injury.

CUSTOMER NOTIFICATION

Owners of affected vehicles will be sent a notification of this safety recall.

Do an iN VIN status inquiry to verify eligibility.

Some vehicles affected by this campaign may be in your new or used vehicle inventory.

Failure to repair a vehicle subject to a recall or campaign may subject your dealership to claims or lawsuits from the customer or anyone else harmed as a result of such failure. To see if a vehicle in inventory is affected by this safety recall, do a VIN status inquiry before selling it.

CORRECTIVE ACTION

Inspect the seat belt pretensioner and, if necessary, replace it.

TOOLS INFORMATION

Part Name	Part Number	Quantity
Pull Force Gauge	07AAJ-30AA100	1

NOTE: This special tool was auto-shipped to all dealers in November 2023. **For support or replacements, please contact the Special Tools Hotline at (833) 949-4672.**

PARTS INFORMATION

Part Name	Part Number	Quantity
Pretensioner Assembly Left Front Lap (outer)	81825-30A-A01ZA	1

CUSTOMER INFORMATION: The information in this bulletin is intended for use only by skilled technicians who have the proper tools, equipment, and training to correctly and safely maintain your vehicle. These procedures should not be attempted by “do-it-yourselfers,” and you should not assume this bulletin applies to your vehicle, or that your vehicle has the condition described. To determine whether this information applies, contact an authorized Honda automobile dealer.

WARRANTY CLAIM INFORMATION

Operation Number	Description	Flat Rate Time	Defect Code	Symptom Code	Template ID	Failed Part Number
8545A4	Front seat belt pretensioner inspection only.	0.2 hr	6XS00	NG500	A23098A	81825-30A-A01ZA
8541B2	Replace the driver's side pretensioner (includes inspection).	0.5 hr	6XS00	NG500	A23098B	81825-30A-A01ZA

Skill Level: Repair Technician

INSPECTION PROCEDURE

1. Insert the S-hook of the pull force gauge into the seat belt pretensioner loop to inspect the driver's side.

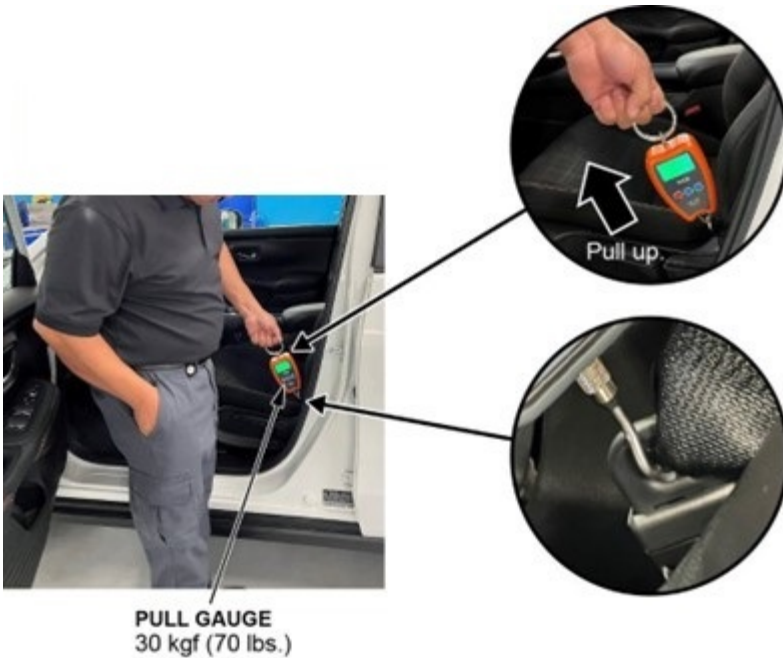

2. While wearing eye protection, carefully pull up and apply a load of **30kgf (70 lbs)**
 - If the pretensioner quick connector remains intact and **DOES NOT** separate from the pretensioner assembly, no further action is required.
 - If the pretensioner quick connector separates from the pretensioner assembly, go to the REPAIR PROCEDURE.

GOOD



NO GOOD



REPAIR PROCEDURE

NOTE: Make sure the vehicle is in the OFF (LOCK) mode.

1. Move the driver's front seat to the rear position and remove the front seat bolts.

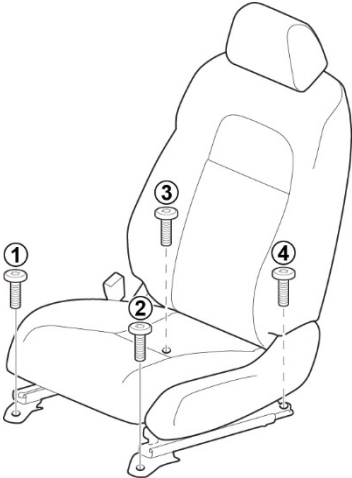

2. Move the driver's front seat to the forwardmost position and remove the rearmost seat bolts.

3. Slide the seat forward.

NOTE: Do not remove the seat.



4. Disconnect the negative cable of the 12-volt battery **4.4 N·m (3.2 lb-ft)**.

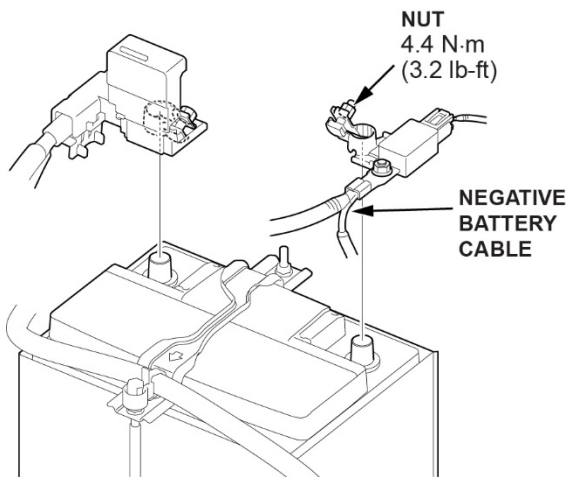

5. Remove the driver's side lower trim, the rear lower trim, and the center B-pillar trim.

Note: Passenger's side images shown for reference only.

DRIVER'S SIDE:

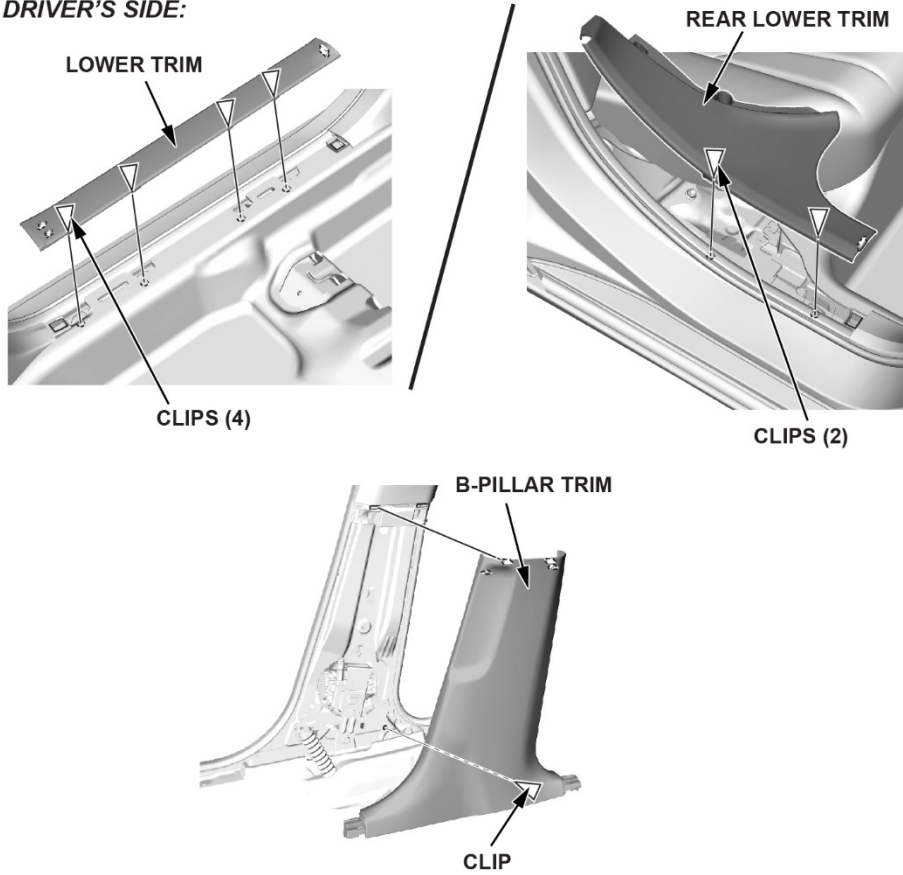

6. Pull back on the carpet as needed to gain access to the seat belt pretensioner bolt.

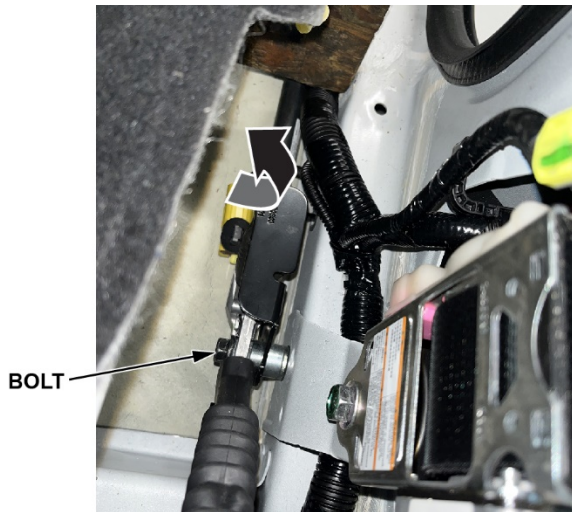

7. Use a small screwdriver to release the seat belt from the quick connector.

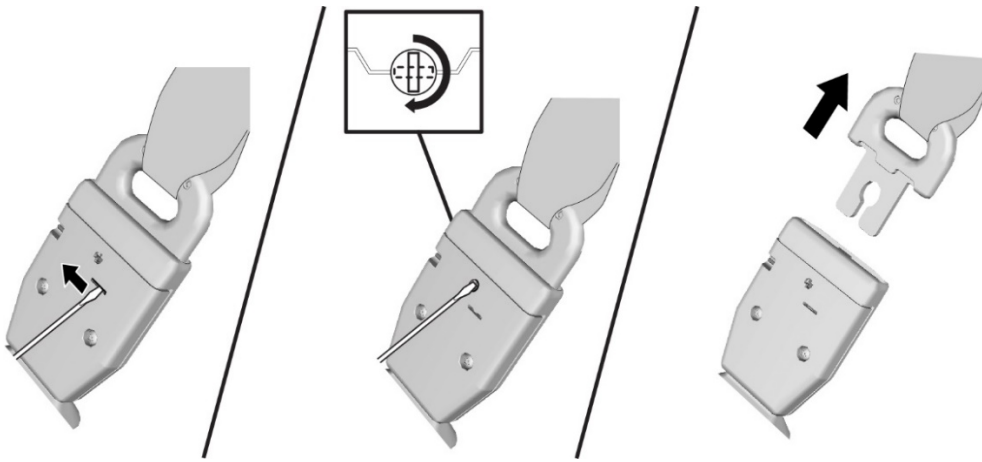

8. Disconnect the driver's seat belt outer lap tensioner connector from the floor wire harness.

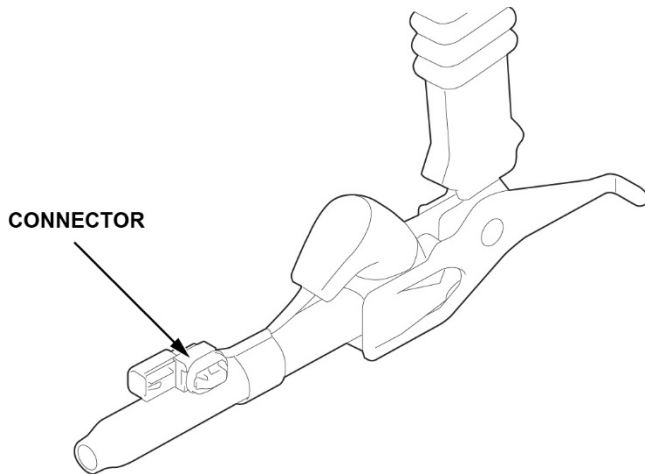

9. Remove the bolt, then remove the pretensioner.

NOTE: Do not use power tools.

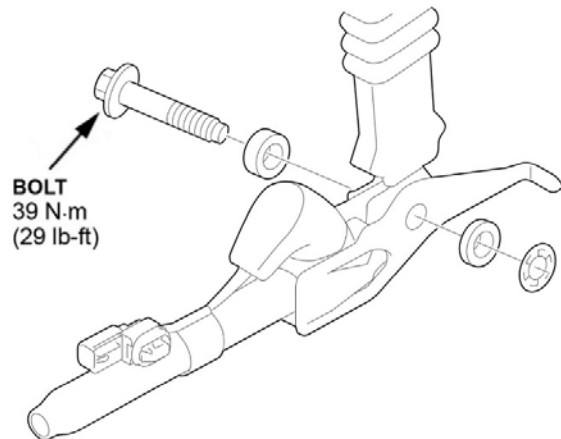

10. Install the new pretensioner and torque the bolt to **39 N·m (29 lb-ft)**.

NOTE:

- **DO NOT** use power tools on installation.
- **DO NOT** reconnect any connectors to the pretensioner unit until fully installed, including torquing the bolts.

11. Connect the connector to the pretensioner.

12. Connect the negative cable of the 12-volt battery **4.4 N·m (3.2 lb-ft)**.

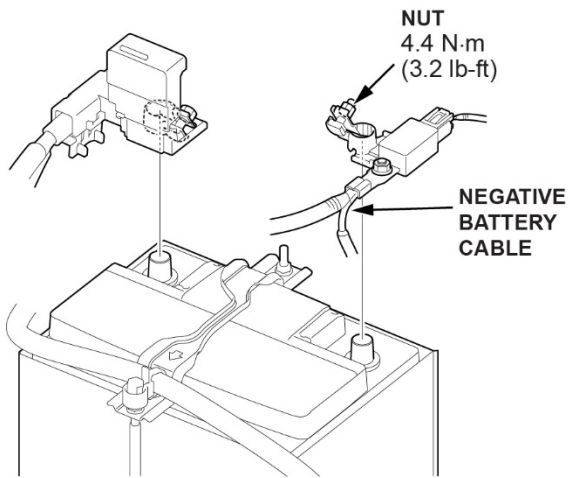

13. Turn the vehicle to the ON mode and check that the SRS indicator comes on for about **6 seconds** and then goes off.

14. Install the trim pieces.

15. Tighten the driver's seat bolts by hand, then torque the front seat to **43 N·m (32 lb-ft)** in the sequence shown.

NOTE: **DO NOT** use power tools.

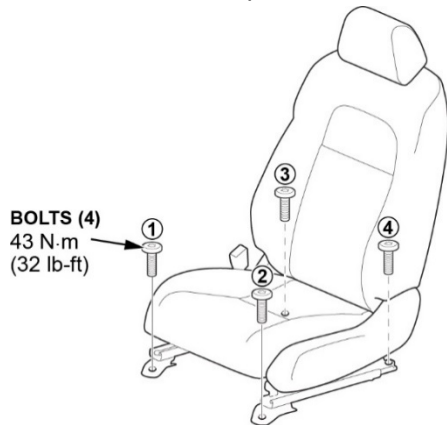

16. Do the Steering Angle Neutral Position Learning procedure.

NOTE:

- Make sure the vehicle is on level ground.
- Make front wheels straight ahead positioned.
- Make sure the i-HDS is connected.
- Do not press the brake pedal during this procedure.

Select the following menu buttons on the HDS screen in sequence:

- **ABS/VSA (System Selection Menu)**
- **ADJUSTMENT**
- **ALL SENSOR**