

SAFETY RECALL

Volvo Trucks North America

Greensboro, NC USA

VOLVO

Date	Number	Release	Page
02. 2024	RVXX2312	01	1(8)

Volvo Passenger Side Bench Seat VHD, VN

RECALL INFORMATION

(February 2024)

Volvo Trucks has determined a safety defect exist on certain VN and VHD model vehicles manufactured from January 2nd, 2018, through October 20th, 2023.

The passenger side bench seat attachment does not meet strength requirements due to inadequate floor reinforcement. In the event of an accident, the passenger bench seat attachment to the floor could fail, increasing the risk of injury.

Volvo Trucks has not received any warranty claims, field reports, or service reports because of this issue.

To ensure the safety of these vehicle, follow the instructions outlined below to remove the passenger seat mounting weld nuts and replace with the fabricated flange nuts/washers supplied in the kit.

VEHICLES AFFECTED

Certain 2019-2024 VN, and VHD vehicles manufactured between January 2nd, 2018, and October 20th, 2023.

VEHICLE QUANTITY

There are 752 vehicles affected by this recall (638 U.S., 114 Canada).

Parts

Part Number	Part description	Quantity
24695924	Repair Kit	1

Repair Instructions

1. Secure vehicle for service by parking on a flat and level surface.
2. Apply parking brake.
3. Place the transmission in neutral or park.
4. Install the wheel chocks.

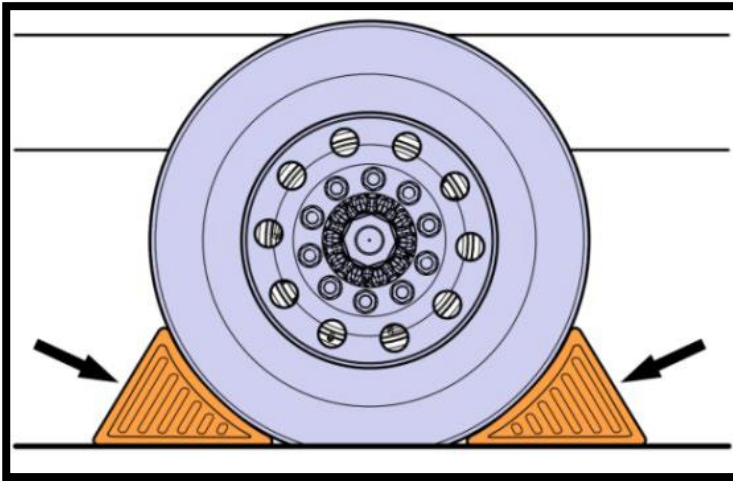

5. Disconnect the battery from the negative terminal.

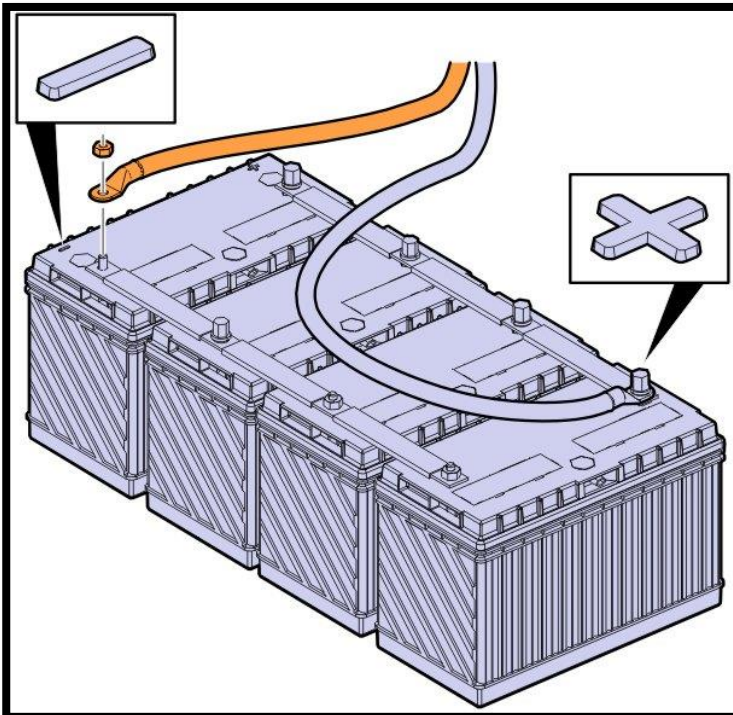

6. Raise the passenger side bench seat up, locate the two mounting bolts that secure the bench seat and tether to the floor.
7. Using a 5/8 socket, remove the back inside bolt and the bolt securing the seatbelt tether.

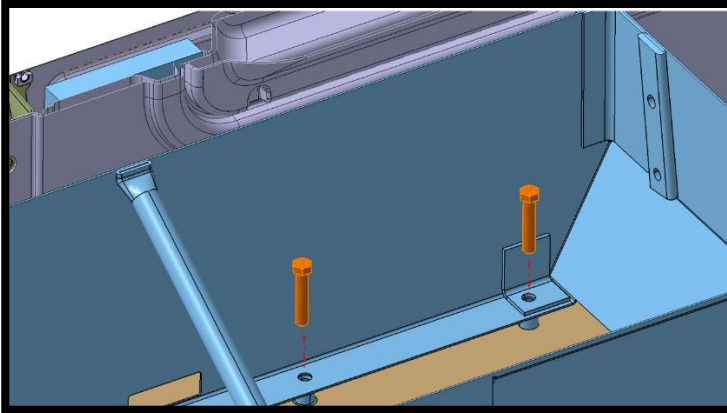

8. Locate the two weld nuts in the channel.

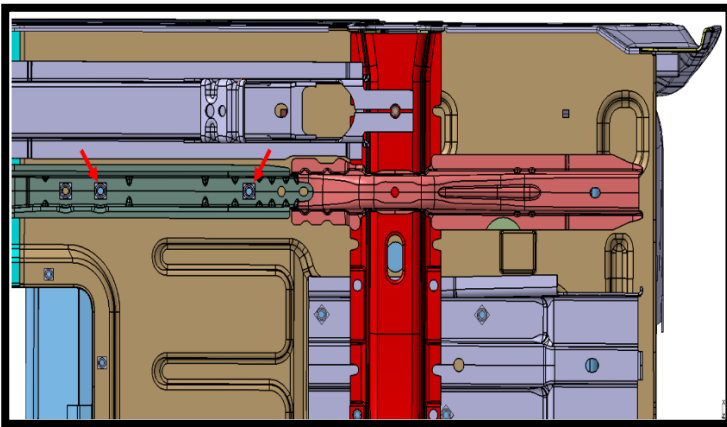

9. Remove the two weld nuts using an air hammer and chisel or equivalent.



10. Once the weld nuts are removed, use a small hammer to flatten the metal back out where the nuts were secured to the reinforcement.



11. Install the original mounting bolts back into the existing holes.

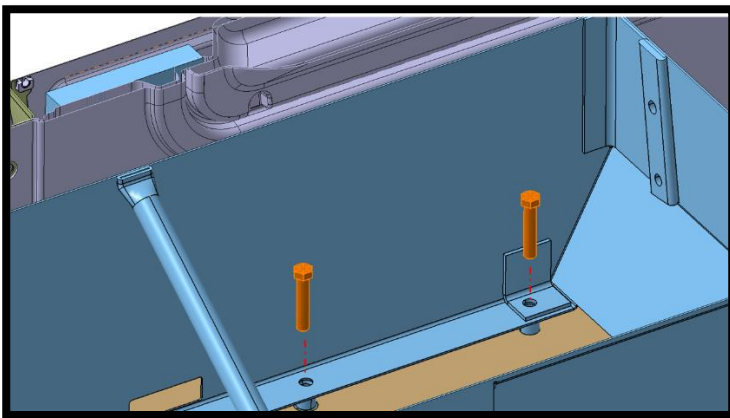

12. Place the two fabricated flange nuts/washers (supplied in the kit) on the table with the washer facing up.

13. Apply a thin layer of epoxy around the washer using the supplied epoxy.

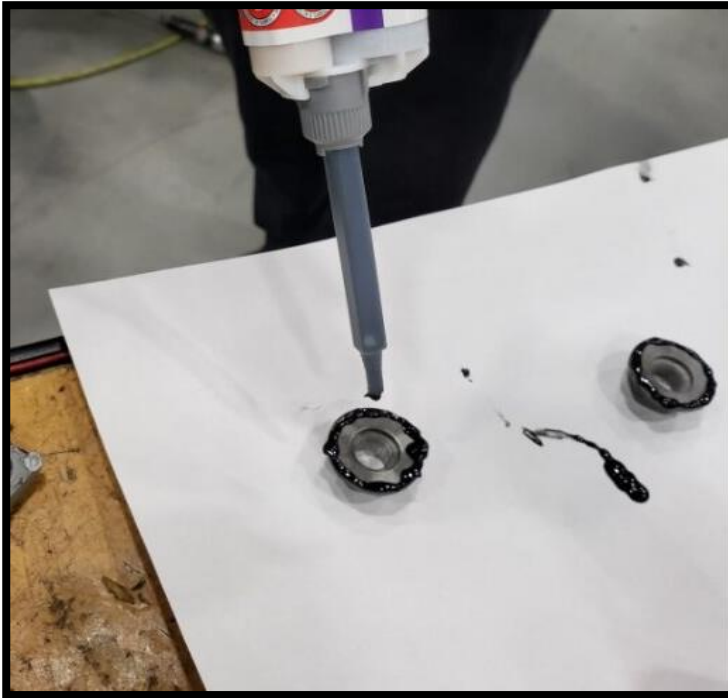

14. Install the fabricated flange nuts/washers on the mounting hardware bolts using a socket and extension to hold the nut.

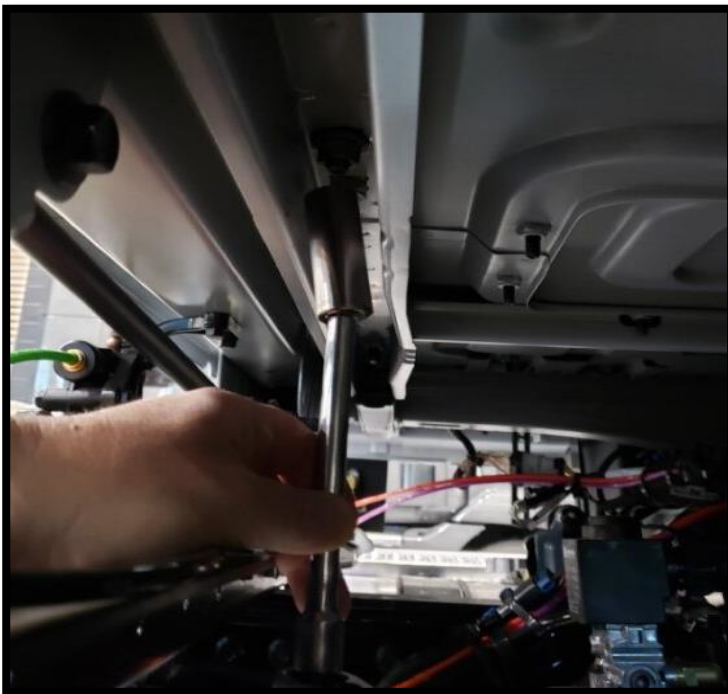

15. Hand-tighten the weld nuts on the two seat mounting hardware bolts.
16. Set torque wrench to **68 Nm (50 lb-ft)**.

Important Note!

Make sure the seat belt tether is facing forward and not sideways.



17. Torque-tighten the seat mounting bolts to specified torque.

Important Note!	
When tightening the seat mounting hardware, torque the securing hardware from the bolt head not the fabricated flange nut/washer.	

Tightening Torque	
Seat mounting, bolts	68 Nm (50 lb-ft)

- 18. Lower the passenger side bench seat.
- 19. Connect the cable to the negative terminal.

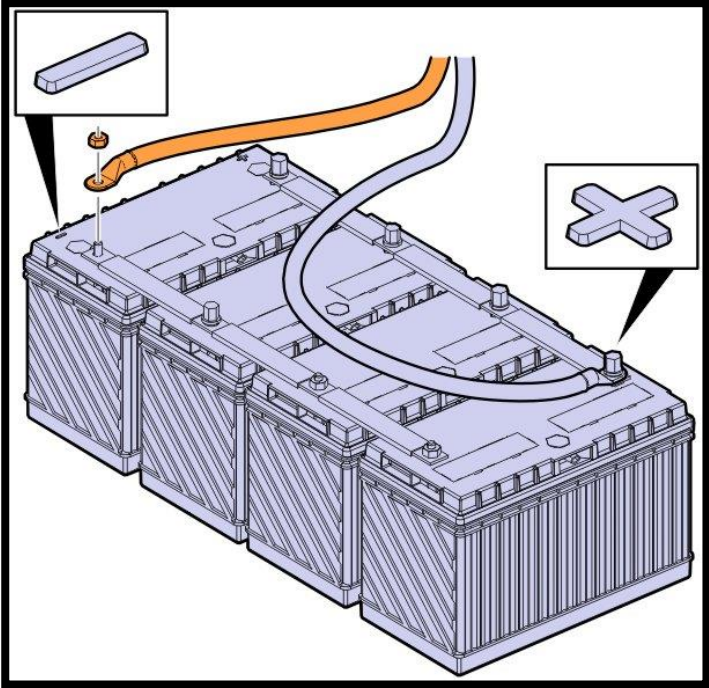

20. Remove the wheel chocks.

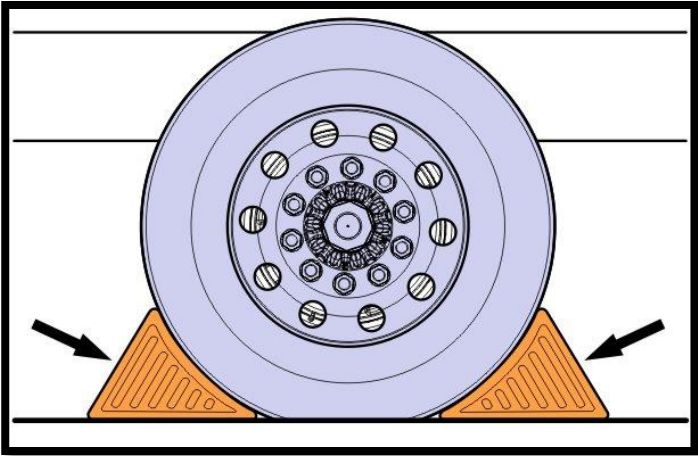

21. Return vehicle to service.

REIMBURSEMENT

This repair is covered by an authorized Safety Recall. Reimbursement is obtained through the normal claim handling process.	
	UCHP Reimbursement
Claim Type (used only when uploading from the Dealer Business System)	40
Recall Status	
Vehicle repaired per instructions	1-Modified per instructions
Labor Codes	
Primary Labor Code: 1720-16-09-01 Campaign, General (0.1 X 10)	SRT (0.1 x 10) 1.0 hrs.
Causal Part	60112752
Authorization Number	C0327

Note: Dealers or the designated representatives are required to perform Safety Recall on all subject vehicles at no charge to the vehicle owner regardless of mileage, age of vehicle or ownership (original purchaser or subsequent purchasers). Whenever vehicles that are subject to a Safety Recall are brought to your dealership for service, it is strongly recommended that every effort be made to perform the recall correction before the vehicle is released to the owner.