

Recall Campaign Bulletin



Mercedes-Benz

Campaign No.2024010010, February 2024

TO: ALL MERCEDES-BENZ CENTERS

SUBJECT: **Model A-Class, CLA, GLA, and GLB (177, 118, and 247 platform)
Model Year 2019-2021**

Add Inspection Gauge and Supplemental Booklet for Checking Rear Brake Pads

Mercedes-Benz AG (“MBAG”), the manufacture of Mercedes-Benz vehicles, has determined that certain MY 2019-2021 A-Class, CLA, GLA and GLB (177, 118, 247 platform) vehicles might not be equipped with the inspection gauge for checking the wear of the rear axle brake pads. Furthermore, the respective information for using this inspection gauge might not be included in the owner’s manual. An authorized Mercedes-Benz dealer will add a brake inspection gauge and the respective owner’s manual information to the affected vehicles, if necessary.

Prior to performing this Campaign:

- **VMI must be checked before performing campaigns to verify that the campaign is required on a specific vehicle. Always check for any other open campaigns, and perform accordingly.**
- Please review the entire Campaign bulletin and follow the repair procedure exactly as described.

Approximately 42,742 vehicles are affected.

Order No. P-RC-2024010010

Recall Campaign Bulletin

Recall Campaign Bulletin

Recall Campaign Bulletin

Recall Campaign Bulletin

Recall Campaign Bulletin

Add Inspection Gauge and Supplemental Booklet for Checking Rear Brake Pads

Work Procedure

1. Open vehicle booklet and check whether gauge (**Figure 1**) is present; enclose if necessary.
2. Check whether supplementary booklet (**Figure 2**) is present; enclose if necessary.

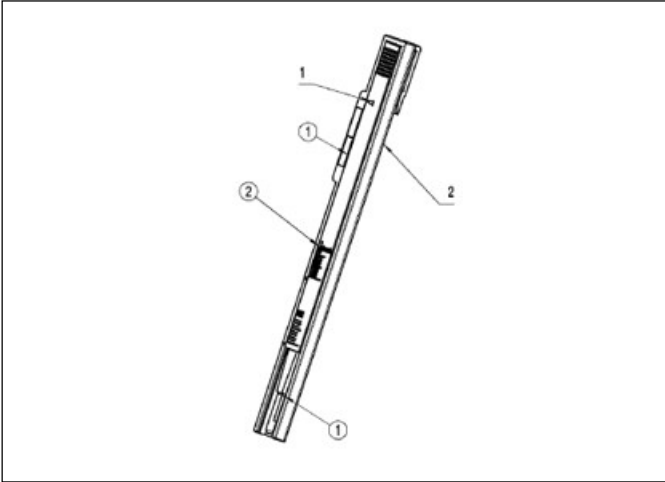

Figure 1 (Gauge A 000 583 06 42)

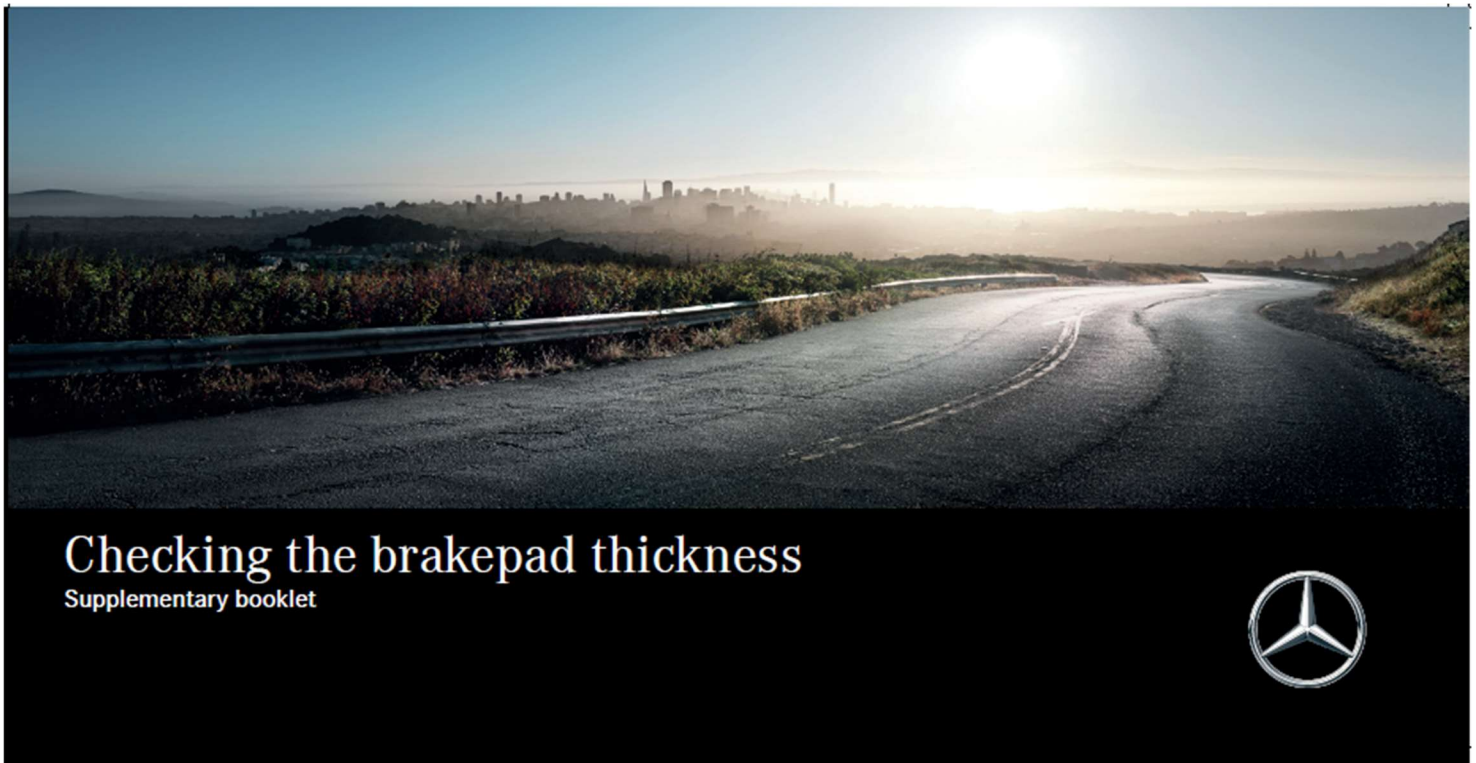

Figure 2 (Supplementary Booklet)

Primary Parts Information

Qty.	Part Name	Part Number
As required (1)	Gauge	A 000 583 06 42
As required (1)	Supplementary booklet	A 118 584 63 04

i **Note:** *The following allowable labor operation should be used when submitting a warranty claim for this repair:*

Warranty Information

Damage Code	Operation Number	Description	Labor Time (hrs.)
42 960 05	02-9471	Check if inspection gauge and supplementary booklet are present, enclose if necessary	0.1

i **Note:** *Always check Xentry Operation Time (XOT) for the current OP-Code times. Labor times are subject to change and updates may not be reflected in this document.*