

# **TECHNICAL INSTRUCTIONS**

**FOR**

**SAFETY RECALL 23TA12**

**Front Lower Bumper Cover Assembly May Detach While Driving**

**CERTAIN 2020-2023 MODEL YEAR HIGHLANDER AND HIGHLANDER HV**

The repair quality of covered vehicles is extremely important to Toyota. All dealership technicians performing this repair are required to successfully complete the most current version of the E-Learning course “Safety Recall and Service Campaign Essentials”. To ensure that all vehicles have the repair performed correctly; technicians performing this repair are required to have currently completed the following courses:

**TIC206A – Toyota Electrical Circuit Diagnosis**

**Always check which technicians can perform the repair by logging on to <https://www.utodealerreports.com>. It is the dealership’s responsibility to select technicians with the above course completed to perform this repair. Carefully review your resources, the technician’s skill level, and ability before assigning technicians to this repair. It is important to consider technician days off and vacation schedules to ensure there are properly trained technicians available to perform this repair at all times.**

# I. OPERATION FLOW CHART

The flow chart is for reference only. **DO NOT** use it in place of the full technical instructions. Follow **ALL** steps as outlined in the full technical instructions to confirm the campaign is completed correctly.

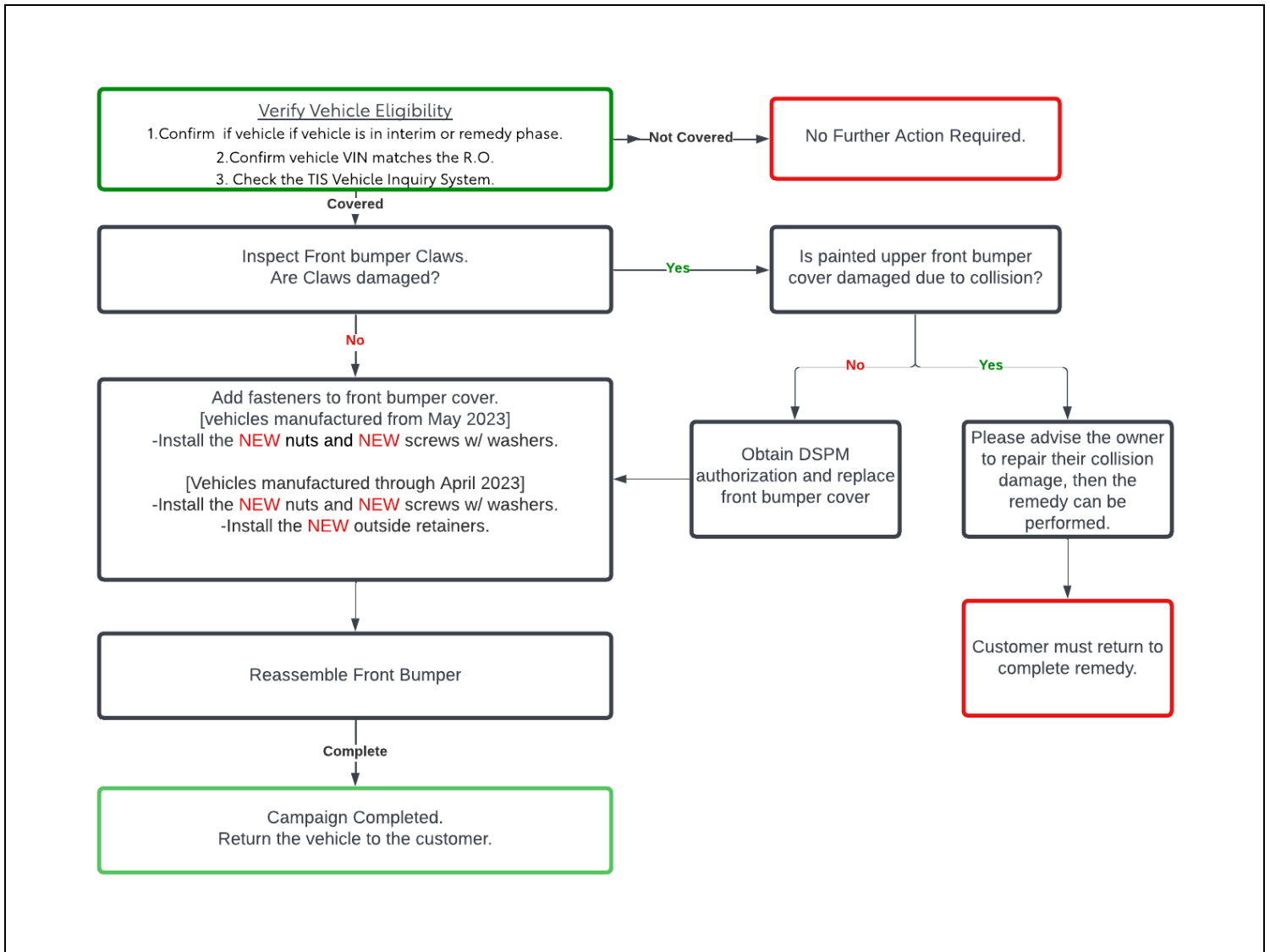

## II. IDENTIFICATION OF AFFECTED VEHICLES

### 1. CHECK VEHICLE FOR CAMPAIGN ELIGIBILITY

- Compare the vehicle's VIN to the VIN listed on the Repair Order to ensure they match.
- Check the TIS Vehicle Inquiry System to confirm the VIN is involved in this Campaign, and that it has not already been completed.

HINT: TMNA warranty will not reimburse dealers for repairs completed on vehicles that are not affected or were previously completed, even by another dealer

## III. PREPARATION

### 1. PARTS

#### All Vehicles (regardless of inspection result)

Part Number	Part Description	Quantity	Remarks
NUT	04003-4510E	1	-
SCREW W/ WASHER	04003-5010E	1	-

#### Production Range 6/2019-4/2023 (regardless of inspection result)

Part Number	Part Description	Quantity	Remarks
OUTSIDE RETAINER	04003-4810R	1	-

#### If the Inspection Result is **NG**

Part Number	Part Description	Quantity	Remarks
FRONT BUMPER COVER	52119-0E950	1	-
FRONT BUMPER COVER	52119-0E951		
FRONT BUMPER COVER	52119-0E980		
FRONT BUMPER COVER	52119-0E981		
COVER, FRONT BUMPER LOWER	52129-0E070	1	Platinum package
COVER, FRONT BUMPER LOWER	52129-0E100		
FRONT FENDER WHEEL OPENING MOULDING CLIP	75867-68010	4	-
ULTRASONIC SENSOR CLIP	89348-50050	4	w/ Intuitive Parking Assist System
ULTRASONIC SENSOR CLIP	89348-50050	1	w/o Intuitive Parking Assist System
FRONT CENTER ULTRASONIC SENSOR RETAINER	89348-58110	2	w/ Intuitive Parking Assist System
FRONT CORNER ULTRASONIC SENSOR RETAINER	89348-48160-A0	2	w/ Intuitive Parking Assist System
FRONT CORNER ULTRASONIC SENSOR RETAINER	89348-48160-A3		
FRONT CORNER ULTRASONIC SENSOR RETAINER	89348-48160-B0		
FRONT CORNER ULTRASONIC SENSOR RETAINER	89348-48160-B1		
FRONT CORNER ULTRASONIC	89348-48160-B2		

SENSOR RETAINER			
FRONT CORNER ULTRASONIC SENSOR RETAINER	89348-48160-C0		
FRONT CORNER ULTRASONIC SENSOR RETAINER	89348-48160-D0		
FRONT CORNER ULTRASONIC SENSOR RETAINER	89348-48160-E0		
FRONT CORNER ULTRASONIC SENSOR RETAINER	89348-48160-G0		
FRONT CORNER ULTRASONIC SENSOR RETAINER	89348-48160-J0		

## 2. TOOLS & EQUIPMENT

a) If the inspection result is **OK**.

• Standard Hand Tools	• Torque Wrench
-----------------------	-----------------

b) If the inspection result is **NG**.

• Standard Hand Tools	• Techstream / GTS+	• Torque Wrench
-----------------------	---------------------	-----------------

SST – These Special Service Tools are required for this repair:

Part Number	Tool Name	Quantity
09870-30010	Marker Tool Set	1

## 3. MATERIALS

a) If the inspection result is **OK**.

• Protective Tape	• Protective gloves	• Marker
-------------------	---------------------	----------

b) If the inspection result is **NG**.

• Protective Tape	• Protective gloves	• Marker
• Weight with a Pointed Tip	• String	

## IV. BACKGROUND

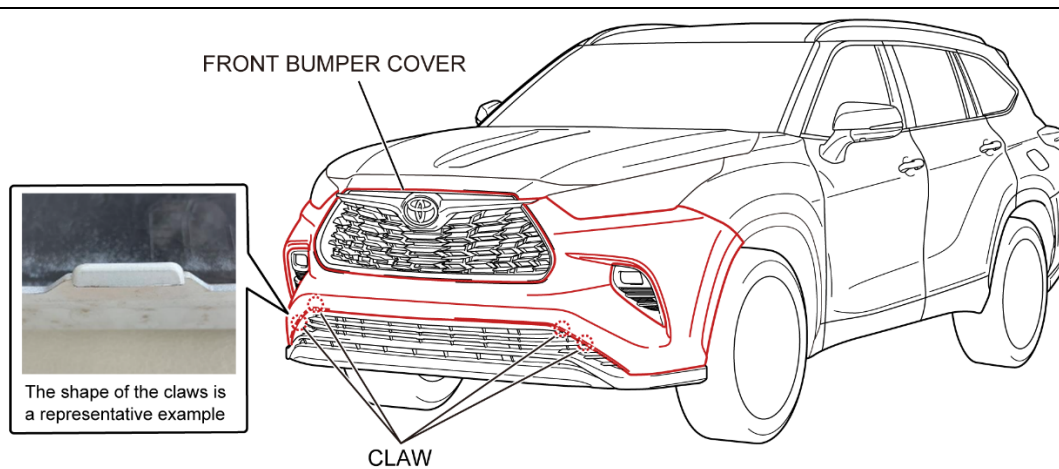

Add fasteners to the front bumper cover

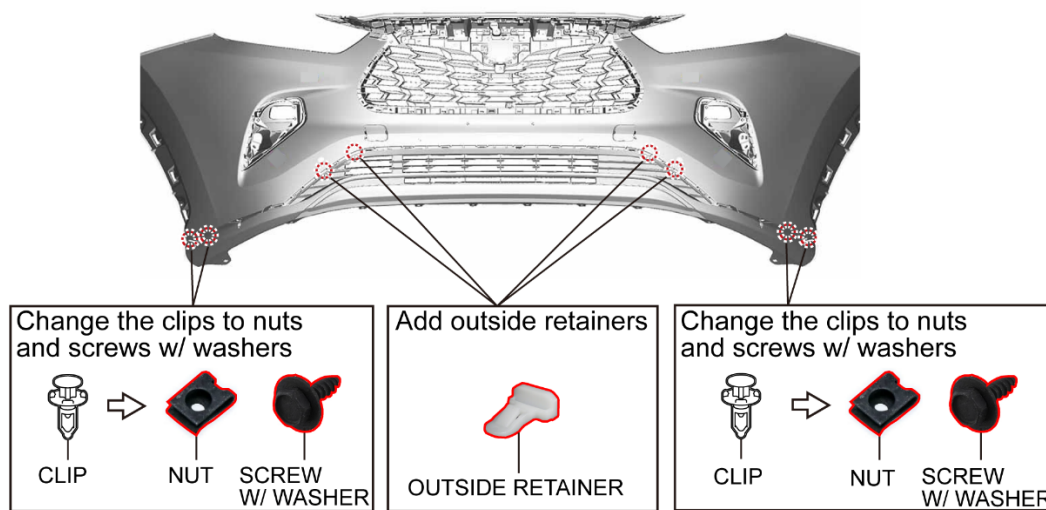

A090186J01001aS

# V. COMPONENTS

## 1. ALL AFFECTED VEHICLES:

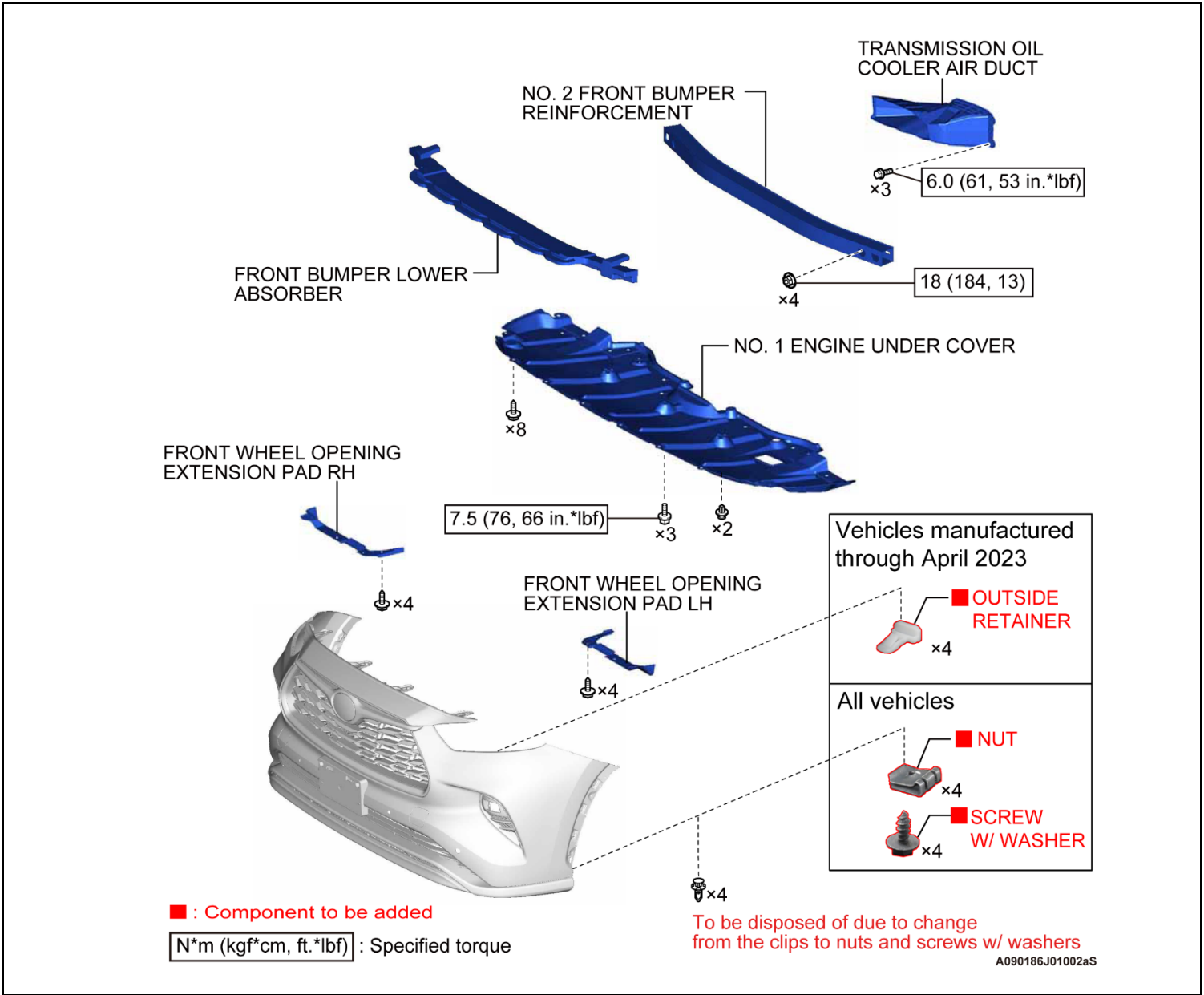

2. IF INSPECTION RESULT IS NG (PART A):

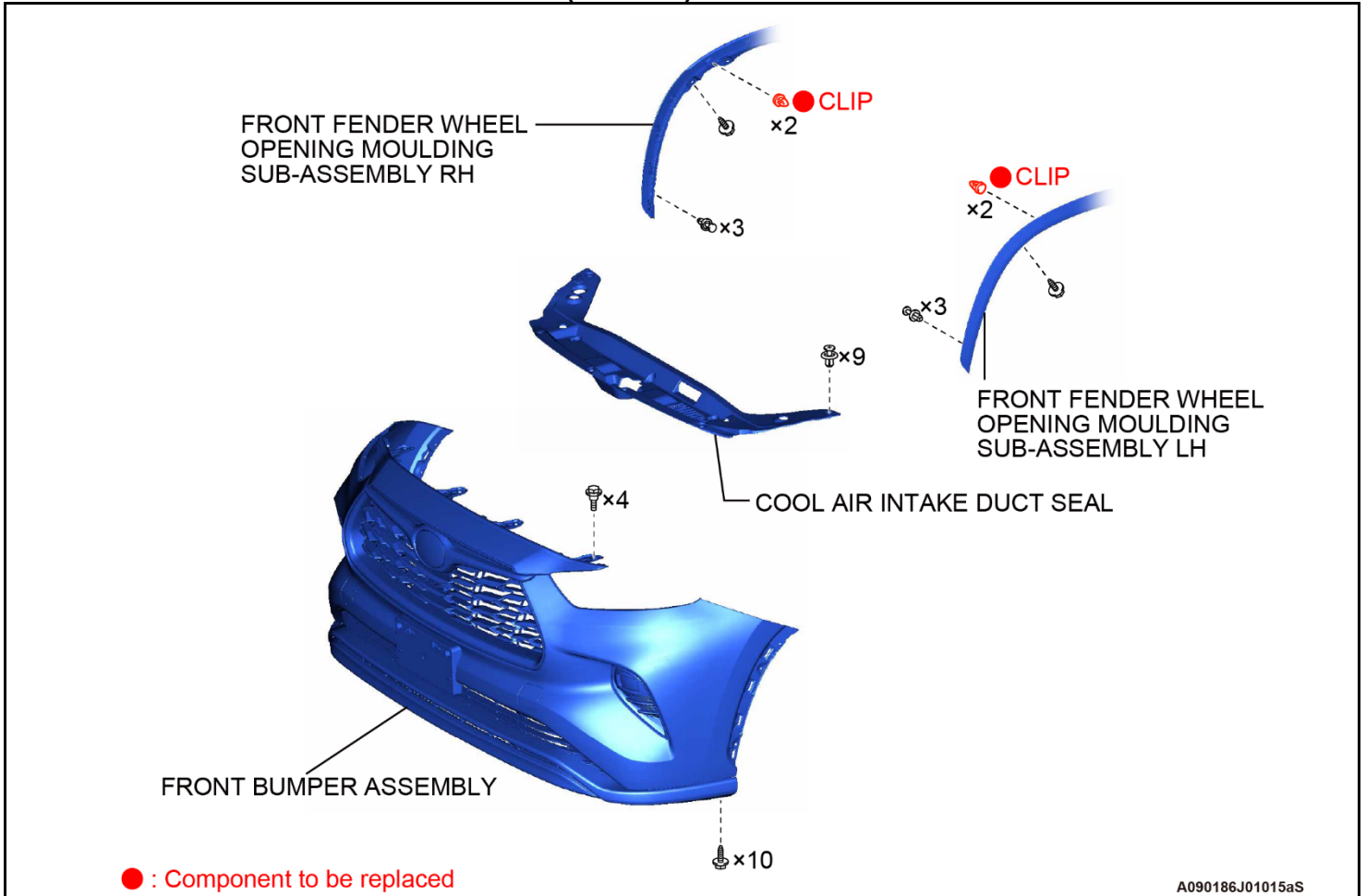

**3. IF INSPECTION RESULT IS NG (PART B):**

w/ Intuitive Parking Assist System  
w/o Panoramic View Monitor System

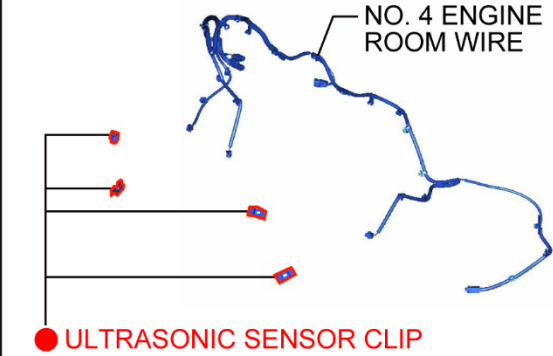

w/ Intuitive Parking Assist System  
w/ Panoramic View Monitor System

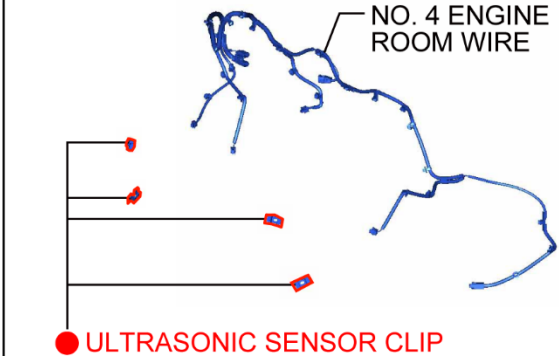

w/o Intuitive Parking Assist System



w/ Fog Light

FOG LIGHT ASSEMBLY RH

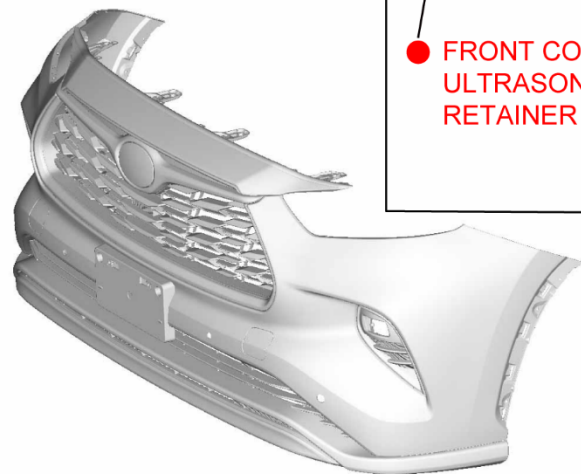

w/ Intuitive Parking Assist System

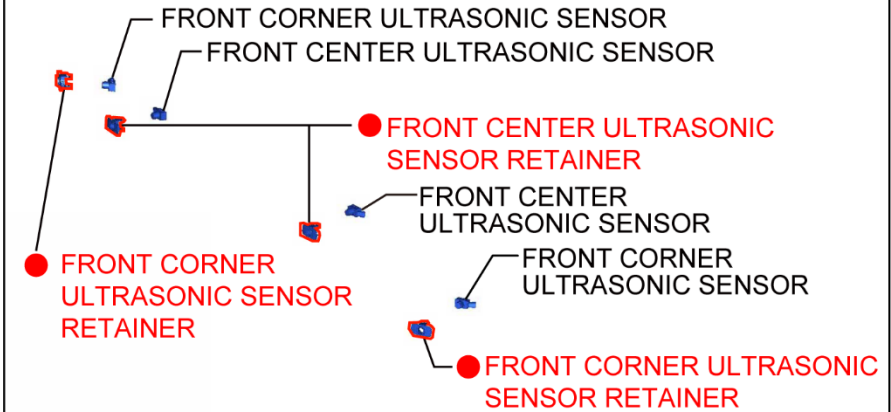

w/ Fog Light

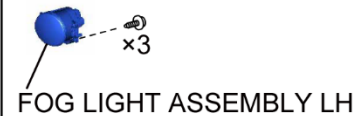

● : Component to be replaced

**N\*m (kgf\*cm, ft.\*lbf)** : Specified torque



4. IF INSPECTION RESULT IS NG (PART C):

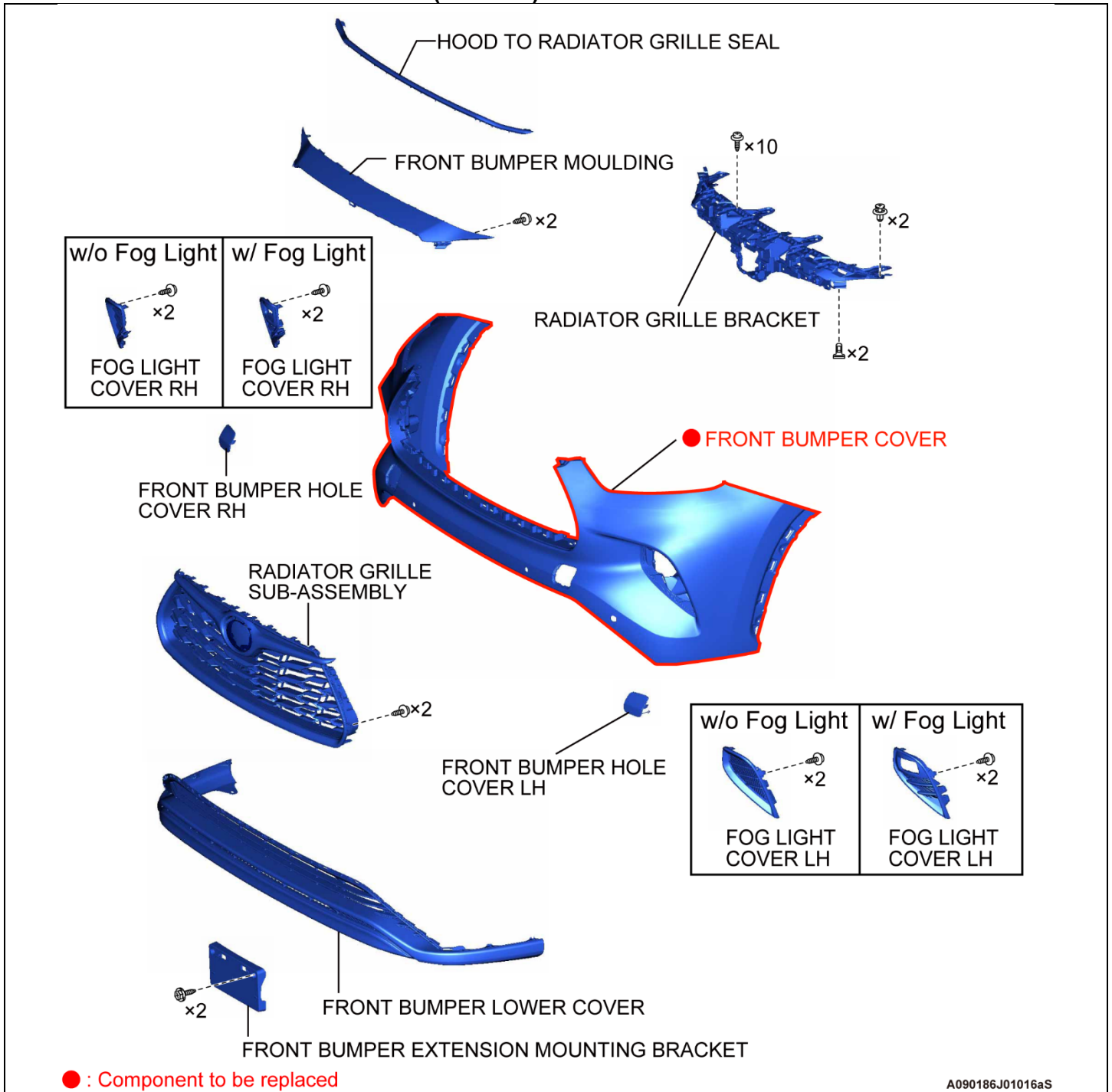

## VI. INSPECTION PROCEDURE

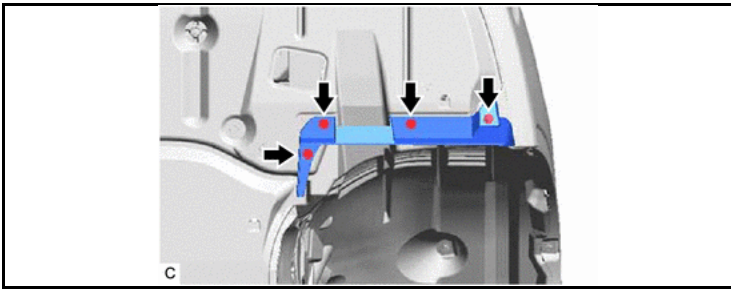

### 1. REMOVE THE FRONT WHEEL OPENING EXTENSION PAD LH

- a) Remove the 4 screws and front wheel opening extension pad LH.

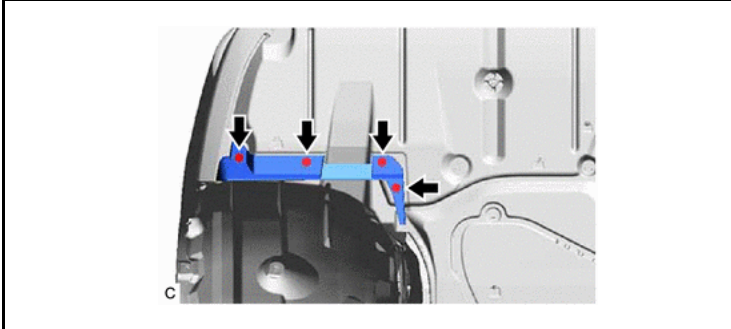

### 2. REMOVE THE FRONT WHEEL OPENING EXTENSION PAD RH

- a) Remove the 4 screws and front wheel opening extension pad RH.

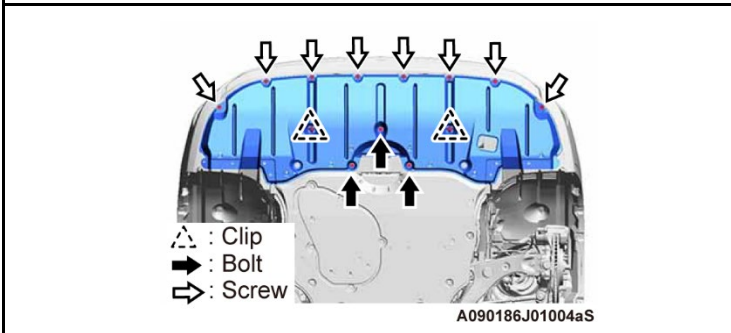

### 3. REMOVE NO. 1 ENGINE UNDER COVER

- a) Remove the 3 bolts, 8 screws, 2 clips and No. 1 engine under cover.

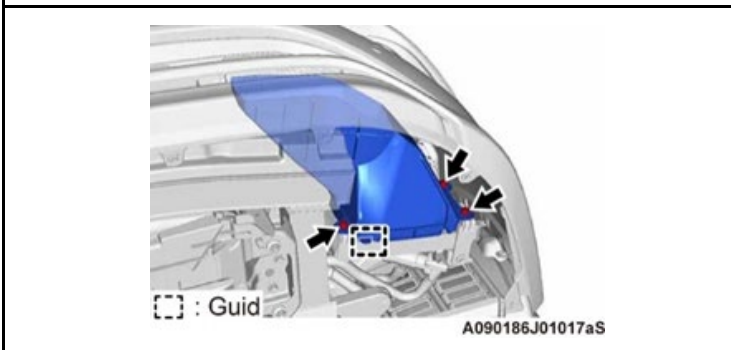

### 4. UNBOLT THE TRANSMISSION OIL COOLER AIR DUCT (IF APPLICABLE)

- a) Remove the 3 bolts from the transmission oil cooler duct located on the driver's side front bumper.

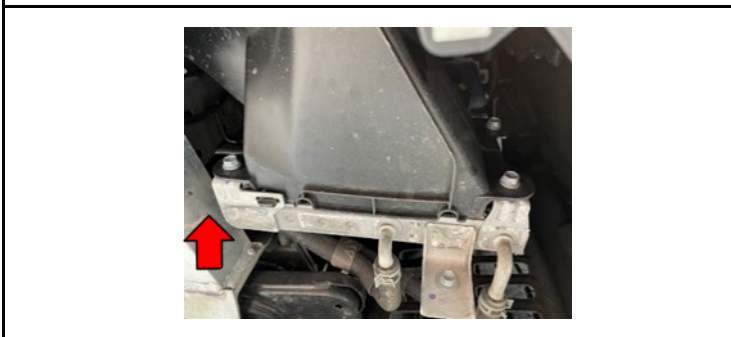

- b) Disengage the guide to remove the transmission oil cooler air duct from the oil cooler assembly.

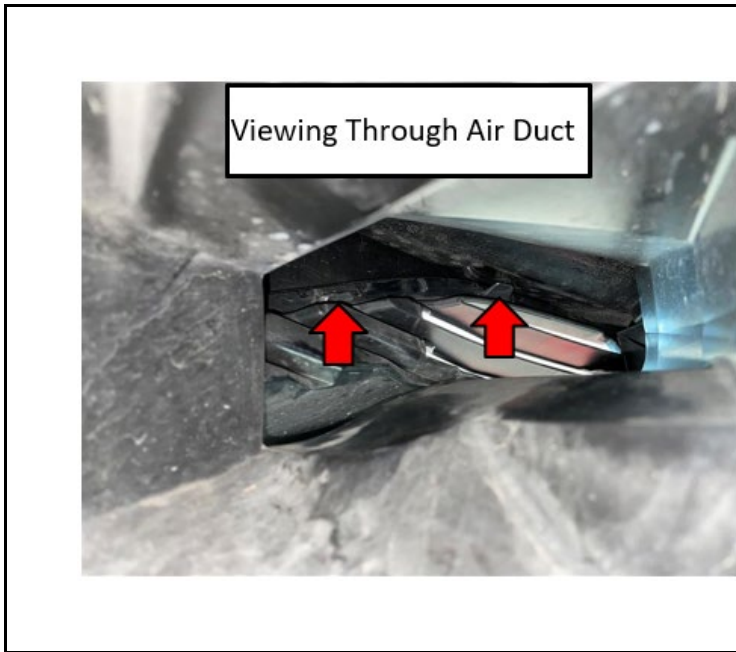

- c) Turn the air duct so that the upper driver's side bumper cover claws can be viewed by peering through the tube with a flashlight.

**5. INSPECT FRONT BUMPER COVER CLAWS**

a) Check for damage on the 4 claws (shown in the picture) and check that all the claws are engaged.

**NOTICE:**

If the painted upper front bumper cover is damaged from obvious collision, please advise the owner to repair their collision damage then the remedy can be performed.

**HINT:**

If the claws cannot be easily seen, use a mirror.

b) If disengaged claws were found in the inspection instructed in step a), engage them.

Inspect the 4 claws of the front bumper cover

Result	: Short	: Long
<b>OK</b>		
<b>NG</b>		

AC00196.M010006.5

Inspection Result	Damaged Claws	Action			Go to
		Install <b>NEW</b> nuts and <b>NEW</b> screws w/ washers	Install <b>NEW</b> outside retainers. [Vehicles manufactured through April 2023]	Replace the front bumper cover with a <b>NEW</b> one*	
<b>OK</b>	Not Found	●	●	-	<b>GO TO SECTION VII</b>
<b>NG</b>	Found	●	●	●	<b>GO TO SECTION X</b>

**\*NOTICE:**

If upper front bumper cover is damaged from obvious collision damage, please advise the owner to repair their collision damage, then the remedy can be performed.

## VII. ADD FASTENERS TO THE FRONT BUMPER COVER (ALL AFFECTED VEHICLES)

### 1. INSTALL NEW NUTS AND NEW SCREWS AND WASHERS

- a) Remove the 4 clips.



- b) Mark or destroy the removed 4 clips and store them in a separate container to prevent accidental reuse.

- c) Install the 4 **NEW** nuts.

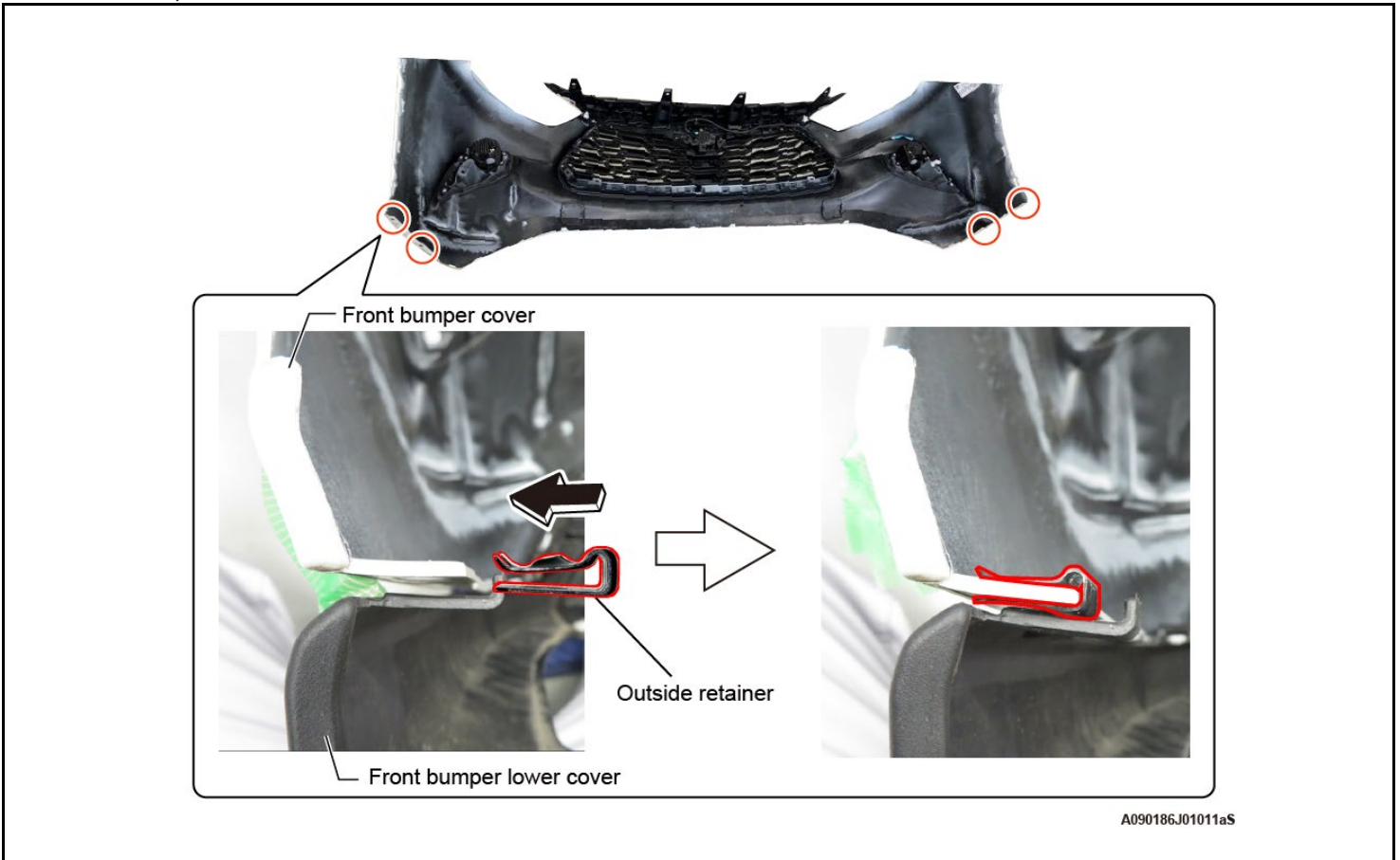

- d) Install the 4 **NEW** screws and washers.
- e) Confirm alignment of bumper and fender alignment when fastening.

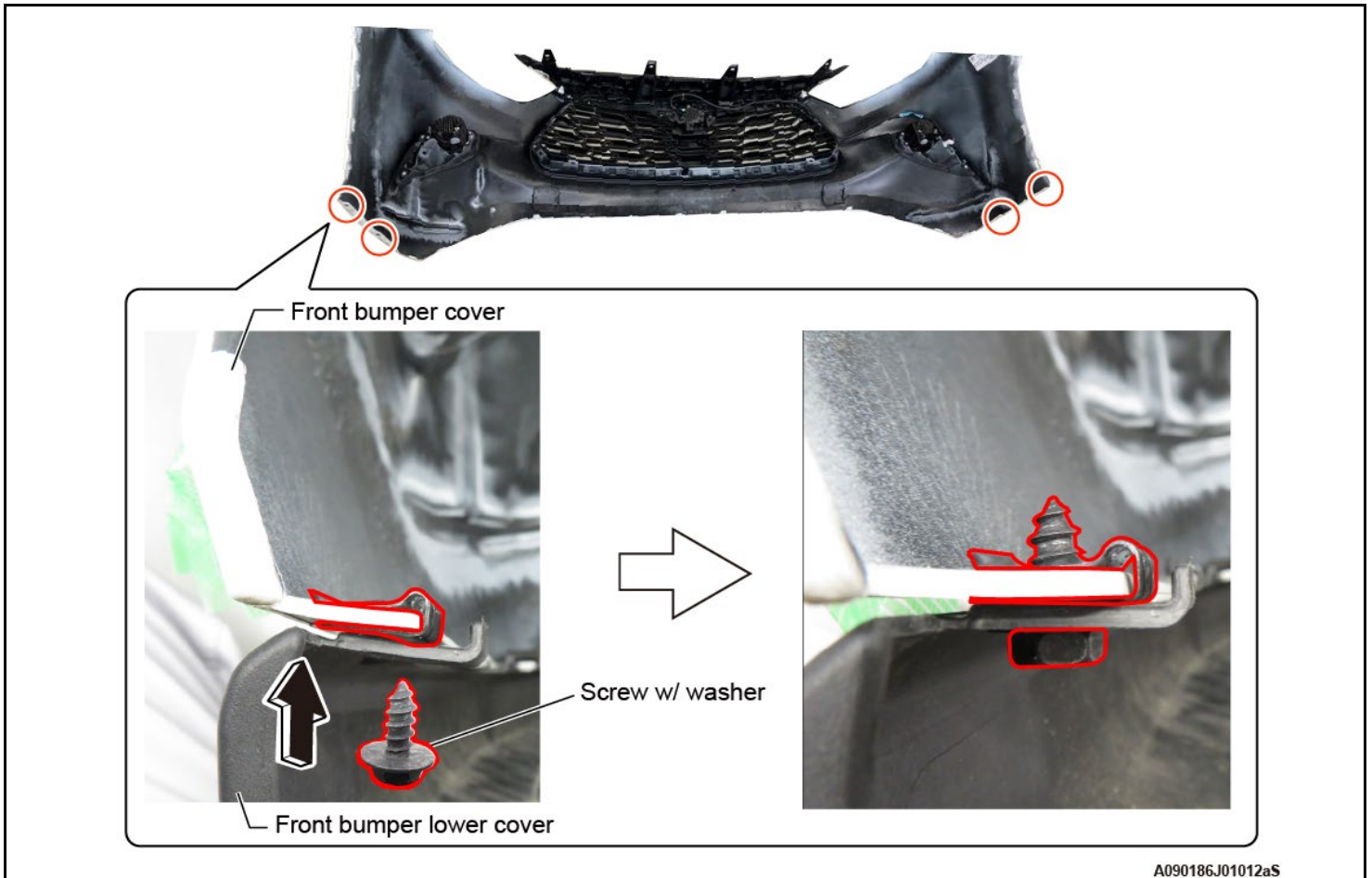

A090186J01012aS

# Vehicle Production Period

From May 2023

Through April  
2023

**GO TO SECTION IX**

**GO TO SECTION VIII**

**VIII. ADD FASTENERS TO THE FRONT BUMPER COVER (VEHICLES MANUFACTURED THROUGH APRIL 2023)**

**1. INSTALL NEW OUTSIDE RETAINERS**

- a) Install the 4 NEW outside retainers to the locations shown in the picture.

**NOTE: Some vehicles manufactured through April 2023 may already have new outside retainers installed from the plant. If new outside retainers are already present, proceed to Section IX.**

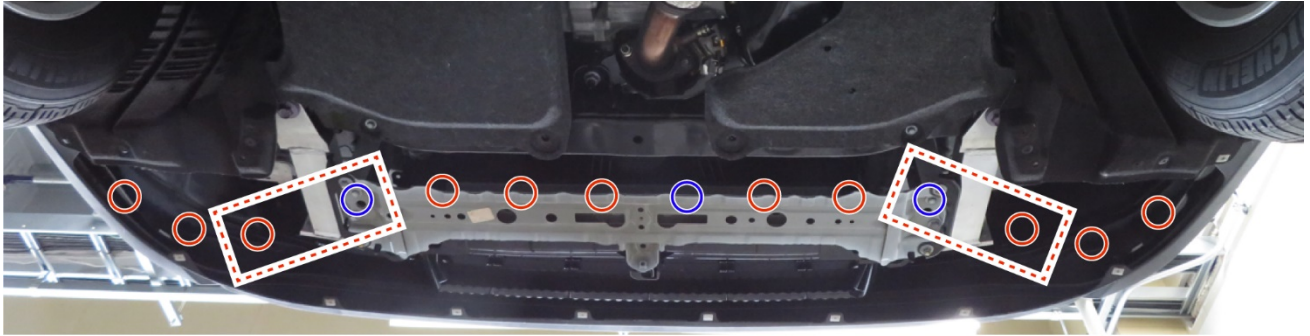

Install the 4 **NEW** outside retainers to the front bumper cover

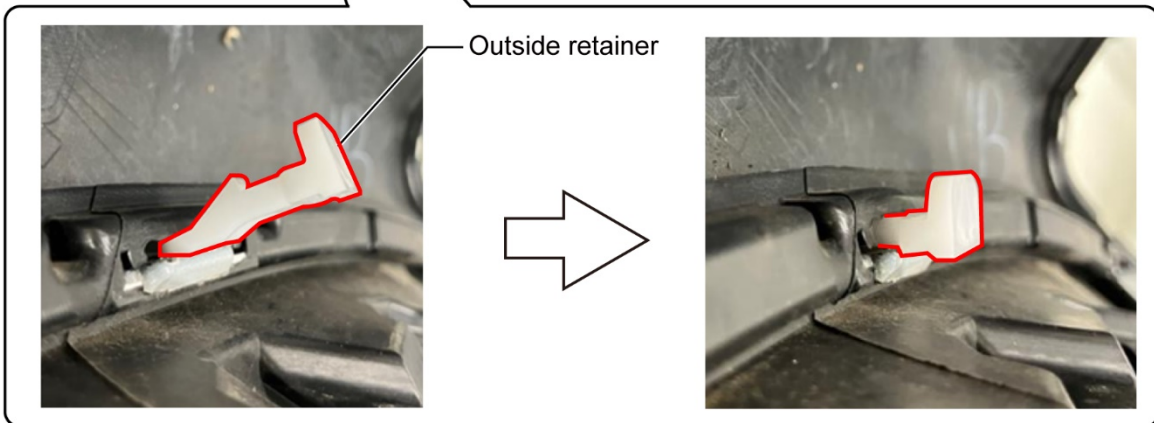
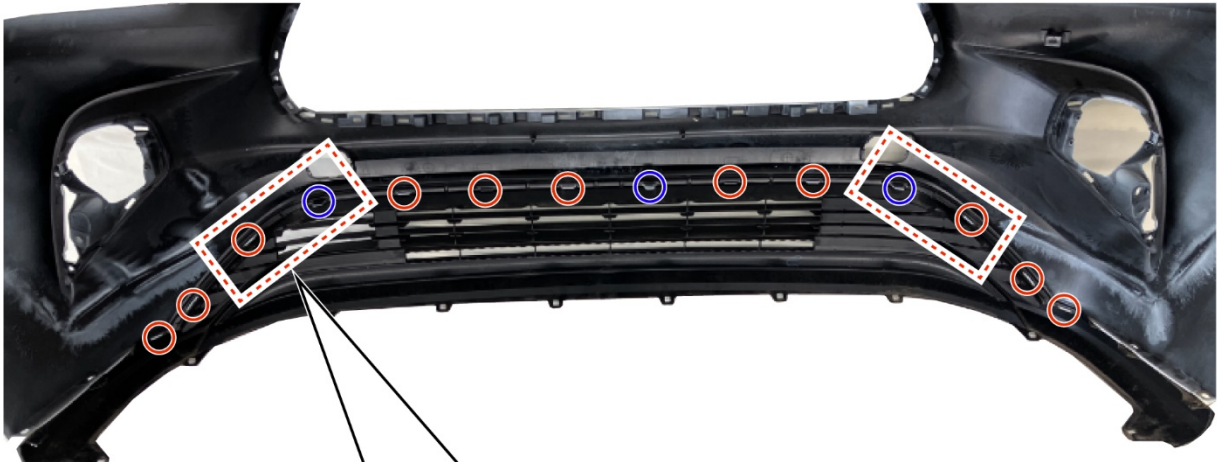

A090186J01013aS



## IX. RETURN VEHICLE TO ORIGINAL STATE (IF INSPECTION RESULT OK)

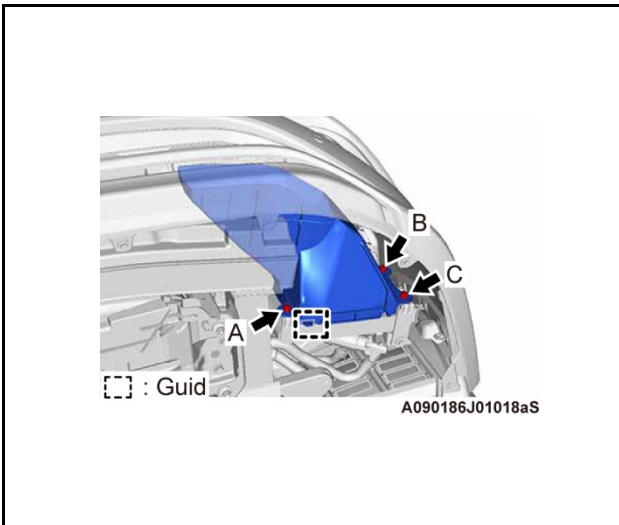

### 1. REINSTALL TRANSMISSION OIL COOLER AIR DUCT

- c) Re-engage the guide to temporarily reinstall the transmission oil cooler air duct to the oil cooler assembly.
- d) Reinstall the transmission oil cooler air duct to the oil cooler assembly with the 3 bolts.

**Torque:**

**6.0 N\*m (61 kgf\*cm, 53 in.\*lbf)**

**HINT:**

Tightening order: Bolt (A) → Bolt (B) → Bolt (C)

- e) Remove the protective tape.

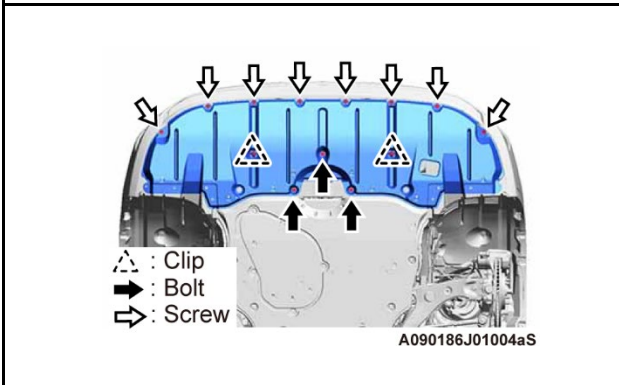

### 2. REINSTALL NO. 1 ENGINE UNDER COVER

- a) Reinstall the No. 1 engine under cover with the 3 bolts, 8 screws and 2 clips.

**Torque:**

**Bolt: 7.5 N\*m (76 kgf\*cm, 66 in.\*lbf)**

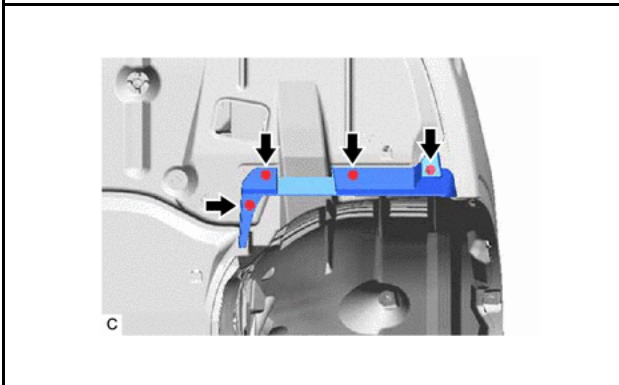

### 3. REINSTALL FRONT WHEEL OPENING EXTENSION PAD LH

- a) Reinstall the front wheel opening extension pad LH with the 4 screws.

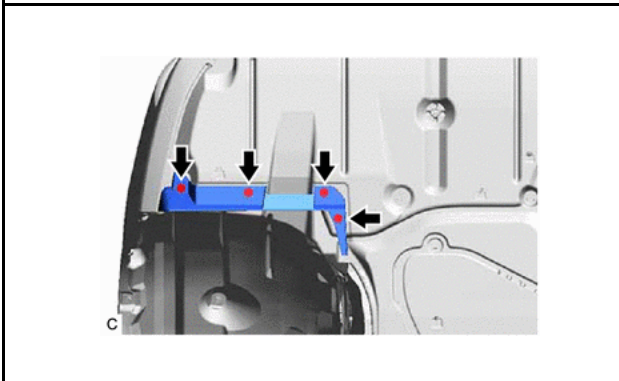

### 4. REINSTALL FRONT WHEEL OPENING EXTENSION PAD RH

- a) Reinstall the front wheel opening extension pad RH with the 4 screws.



## 5. CHECK FOR DTCs

- a. Using Techstream, check for Diagnostic Trouble Codes.

**NOTE:** This Safety Recall covers only the installation of the fuel line kit and associated parts. It does not cover the diagnosis or replacement of any other parts of the vehicle.

## 6. Proceed to Section XI.

## X. REPLACE THE FRONT BUMPER COVER WITH A **NEW** ONE (IF INSPECTION RESULT IS **NG**)

### 1. CHECK FOR DTCs

#### **NOTICE:**

**This campaign covers only the replacement of the front bumper cover and associated parts. It does not cover the vehicle's diagnosis or replacement of any other parts.**

### 2. REMOVE THE FRONT BUMPER ASSEMBLY

[EXTERIOR PANELS / TRIM: FRONT BUMPER \(except Sport Package\): REMOVAL; 2021 - 2023 MY Highlander](#)

- a) For the removed 4 clips (for fastening the front fender wheel opening molding sub-assembly), mark or destroy, and then store them in a separate container so as to not reuse them in error.

### 3. DISASSEMBLE THE FRONT BUMPER COVER

[EXTERIOR PANELS / TRIM: FRONT BUMPER \(except Sport Package\): DISASSEMBLY; 2020 - 2024 MY Highlander](#)

- a) For the removed components listed below, mark or destroy them, and then store them in a separate container so as to not reinstall them in error.
  - Front bumper cover
  - Ultrasonic Sensor Clip
  - Front center ultrasonic sensor retainer
  - Front corner ultrasonic sensor retainer

### 4. ASSEMBLE THE **NEW** FRONT BUMPER COVER

[EXTERIOR PANELS / TRIM: FRONT BUMPER \(except Sport Package\): REASSEMBLY; 2020 - 2024 MY Highlander](#)

### 5. REINSTALL THE FRONT BUMPER ASSEMBLY

[EXTERIOR PANELS / TRIM: FRONT BUMPER \(except Sport Package\): INSTALLATION; 2021 - 2024 MY Highlander](#)



### 6. CHECK FOR DTCs

- b. Using Techstream, check for Diagnostic Trouble Codes.

**NOTE: This Safety Recall covers only the installation of the fuel line kit and associated parts. It does not cover the diagnosis or replacement of any other parts of the vehicle.**

### 7. Proceed to Section XI.

## ◀ VERIFY REPAIR QUALITY ▶

- Confirm that bumper claws are properly installed.
- Confirm that all panels are properly installed.
- Confirm that new bumper is properly installed (if required).
- Confirm all sensors and calibrations are completed (if required).
- Confirm no DTCs exist.

Please contact your regional area representative if you have any questions regarding this update.

## XI. APPENDIX

### A. PARTS DISPOSAL

In accordance with Federal law, please make sure all recalled parts (original parts) removed from the vehicle are disposed of in a manner in which they will not be reused, ***unless requested for parts recovery return.***

## B. CAMPAIGN DESIGNATION DECODER

