



Remedy available for
 2022-2024 (WS) Jeep Wagoneer/Grand
 Wagoneer

Template Version 1.0

Revision	Edition	Detail
2	April 2025	LOP number for "Inspect and Replace Left 3rd Row Seatbelt Buckle " updated.

SYMPTOM DESCRIPTION

The third row seatbelt buckles on about 104,400 of the above vehicles may have been built with buckles that are inaccessible or damaged. An inaccessible or damaged buckle may leave the occupant unable to fasten the seatbelt. If this warning is not heeded, an unfastened seatbelt may increase the risk of injury to occupants during certain types of crashes.

SCOPE

This recall applies only to the above vehicles.

NOTE: Some vehicles above may have been identified as not involved in this recall and therefore have been excluded from this recall.

IMPORTANT: Some of the involved vehicles may be in dealer new vehicle inventory. Federal law requires you to complete this recall service on these vehicles before retail delivery. Dealers should also consider this requirement to apply to used vehicle inventory and should perform this recall on vehicles in for service. Involved vehicles can be determined by using the VIP inquiry process.

REPAIR TO BE PERFORMED

Inspect that the left and center third row seatbelt buckles are accessible and not damaged. Operate the buckles and ensure that they operate properly. If there is visible damage, or they do not operate properly, replace the buckles.

COMPLETION REPORTING / REIMBURSEMENT

Claims for vehicles that have been serviced must be submitted on the DealerCONNECT Claim Entry Screen located on the Service tab. Claims paid will be used by FCA to record recall service completions and provide dealer payments.

NOTE: If buckle replacement is required, and the needed parts are not immediately available, dealers are instructed NOT to claim a recall LOP for the inspection and instead leave the R.O. open until the part is installed and then can claim the installation LOP.

Use the following labor operation numbers and time allowances:

Labor Description	Number	Hrs
Inspect Left and Center 3rd Row Seatbelt Buckles	23-A7-A1-80	0.2
Inspect and Replace Center 3rd Row Seatbelt Buckle	23-A7-A1-82	0.7
Inspect and Replace Left and Center 3rd Row Seatbelt Buckles	23-A7-A1-83	1.0
Inspect and Replace Left 3rd Row Seatbelt Buckle	23-A7-A1-84	0.7

NOTE: See the Warranty Administration Manual, Recall Claim Processing Section, for complete recall claim processing instructions.

PARTS INFORMATION

See StarParts for the proper buckle parts numbers.

NOTE: If the needed parts are not immediately available, print out the last page of this document, mark which seating position(s) is not to be used, and provide the page to the customer.

Part No.	Qty.	Part Name
06513060AA (MSQ 5)	4 or 8	Bolt M10 Hex Head
68566474AA	2	Torx Screw

PARTS RETURN

No parts return required for this campaign.

Render the recalled parts unusable and discard.

SPECIAL TOOLS

No special tools are required.

DEALER NOTIFICATION

To view this notification on DealerCONNECT, select “Global Recall System” on the Service tab, then click on the description of this notification.

OWNER NOTIFICATION / SERVICE SCHEDULING

All involved vehicle owners known to FCA are being notified of the service requirement by first class mail. They are requested to schedule appointments for this service with their dealers. A generic copy of the owner letter is attached.

VEHICLE LISTS, GLOBAL RECALL SYSTEM, VIP AND DEALER FOLLOW UP

All involved vehicles have been entered into the DealerCONNECT Global Recall System (GRS) and Vehicle Information Plus (VIP) for dealer inquiry as needed.

GRS provides involved dealers with an updated VIN list of their incomplete vehicles. The owner’s name,

address and phone number are listed if known. Completed vehicles are removed from GRS within several days of repair claim submission.

To use this system, click on the “**Service**” tab and then click on “**Global Recall System**.” Your dealer’s VIN list for each recall displayed can be sorted by: those vehicles that were unsold at recall launch, those with a phone number, city, zip code, or VIN sequence.

Dealers must perform this repair on all unsold vehicles before retail delivery. Dealers should also use the VIN list to follow up with all owners to schedule appointments for this repair.

Recall VIN lists may contain confidential, restricted owner name and address information that was obtained from the Department of Motor Vehicles of various states. Use of this information is permitted for this recall only and is strictly prohibited from all other use.

ADDITIONAL INFORMATION

If you have any questions or need assistance in completing this action, please contact your Service and Parts District Manager.

Customer Services / Field Operations
FCA US LLC.

SERVICE PROCEDURE

WARNING: To avoid serious or fatal injury during and following any seatbelt or child restraint anchor service, carefully inspect all seatbelts, buckles, mounting hardware, retractors, tether straps, and anchors for proper installation, operation, or damage. Replace any belt that is cut, frayed, or torn. Straighten any belt that is twisted. Tighten any loose fasteners. Replace any belt that has a damaged or ineffective buckle or retractor. Replace any belt that has a bent or damaged latch plate or anchor plate. Replace any child restraint anchor or the unit to which the anchor is integral that has been bent or damaged. Never attempt to repair a seatbelt or child restraint component. Always replace damaged or ineffective seatbelt and child restraint components with the correct, new and unused replacement parts listed in the Mopar® Parts Catalog. Failure to follow these instructions may result in possible serious or fatal injury.

NOTE: While removed, do not fold the seat backs down or recline the seat. This will cause the seats to become out of sync to each other, and this condition cannot be corrected.

NOTE: The 3rd row seat front fasteners changed during production. Some vehicles will have a combination of bolts and M10 nuts, while others will have all bolts. Fastener torque values are provided for both fasteners where applicable.

A. Inspect Buckles

1. Inspect that the left and center third row seatbelt buckles are accessible, operate properly and are not damaged. Operate the buckles and ensure that they operate properly. If there is visible damage, they are trapped or they do not operate properly, replace the buckles. See procedures B-I below. If the buckles pass inspection, return the vehicle to the customer and claim the Inspect labor operation to close the recall.

B. Remove Cargo Load Floor (All Seating Positions)

1. Open the liftgate.
2. Using a trim stick or equivalent, release the retaining clips that secure the liftgate sill scuff plate to the rear sill and remove it from the vehicle (Figure 1).



2316185881

Figure 1 – Liftgate Sill Scuff Plate

SAFETY RECALL

NORTH AMERICA

Seatbelt Buckle



Reference: A7A / NHTSA 23V-716

FCA US LLC

3. Long Wheelbase vehicle - Remove fasteners that secure the cargo rails to the rear floor. Remove cargo rails (Figure 2).
4. Open the cargo floor cover.

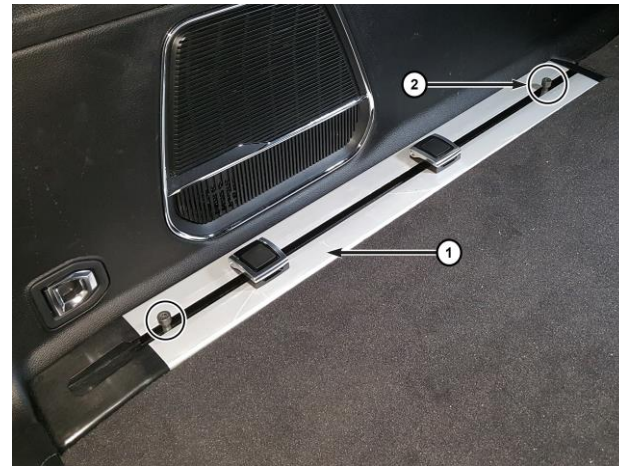
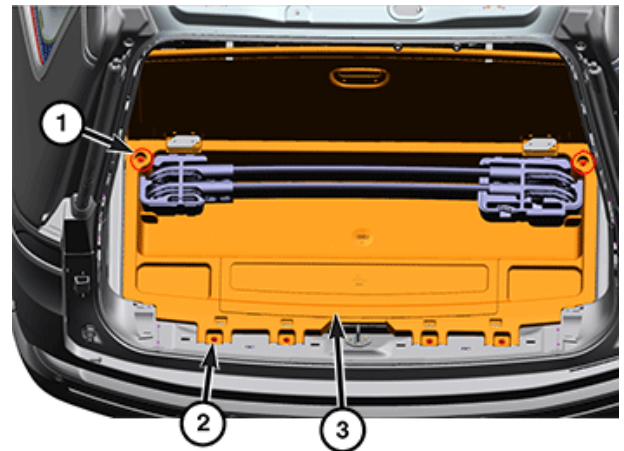

Figure 2 – Cargo Rail Fasteners (Long Wheelbase)

5. Remove the bolts (1) and nuts (2) that secure the cargo load floor (3) to the body (Figure 3).



2316185890

Figure 3 – Cargo Load Floor Fasteners (Short Wheelbase Shown)

6. Remove the cargo load floor (1) from the vehicle (Figure 4).

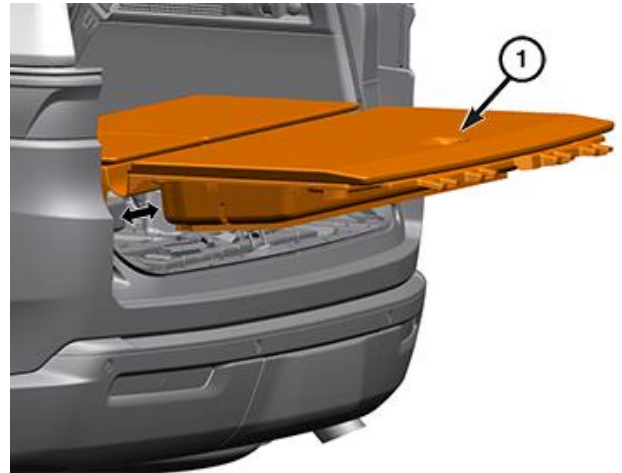

2316185891

Figure 4 – Cargo Load Floor

Third Row Left Seatbelt Buckle (40%)

C. Remove

1. As needed, disengage the retaining tabs and remove the rear air duct (1) from the vehicle (Figure 5).

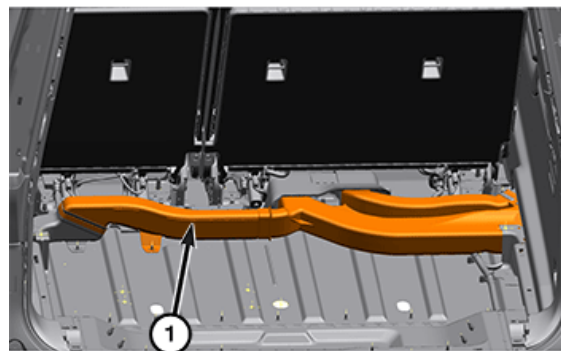

2319195619

Figure 5 – Third Row Left Outer Seat Bolts

2. Remove the third row left outer seat to floor fastener covers and nuts and/or bolts (2) from the front position. **Discard the old bolts** (Figure 6).

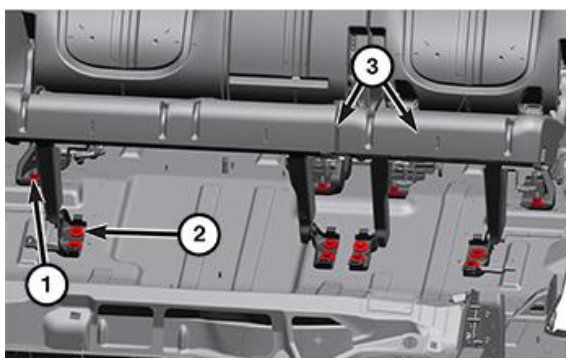

2319195623

Figure 6 – Third Row Left Outer Seat Bolts

3. Remove the third row seat to floor nuts (1) from the rear position (Figure 7).

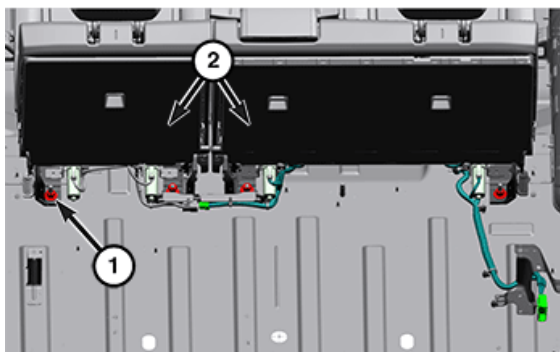

2319195621

Figure 7 – Third Row Left Outer Seat Nuts

SAFETY RECALL

NORTH AMERICA

Seatbelt Buckle



Reference: A7A / NHTSA 23V-716

FCA US LLC

4. Disengage the wire harness retainer (4) from the marriage bracket (3) (Figure 8).
5. Remove the screws (1) from the marriage bracket (3) and remove the bracket from the seats (2). **Discard the screws** (Figure 8).

NOTE: Care should be used when moving the seats to protect the interior trim.

NOTE: While removed, do not fold the seat backs down or recline the seat. This will cause the seats to become out of sync to each other, and this condition cannot be corrected.

NOTE: Ensure the seat is in the upright position and not folded flat when removing from vehicle. The 40% and 60% seats can be serviced separately but must remain in the upright/locked position during the whole time it is removed from the vehicle.

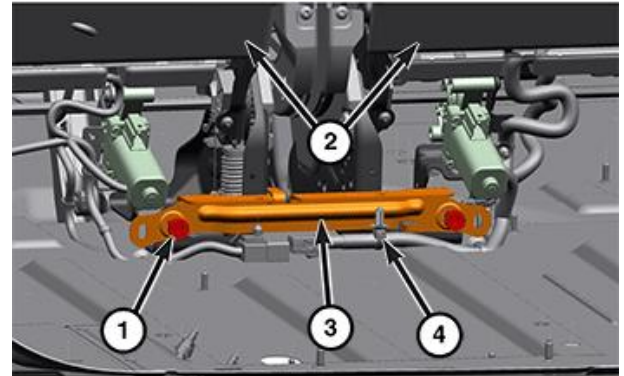

2319195624

Figure 8 – Marriage Bracket Fasteners

6. Roll the seat forward into the footwell.
7. Remove the third row left seatbelt buckle bolt (1) from the buckle anchor (Figure 9).
8. Remove the buckle (2) from the vehicle (Figure 9).

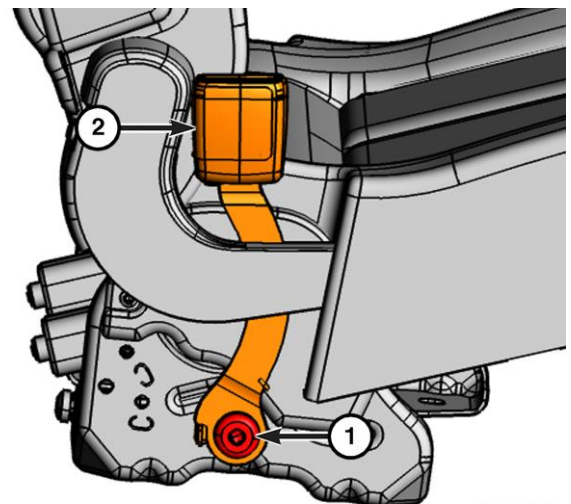

1023170227

Figure 9 – Seatbelt Buckle Fasteners

D. Install

1. Place the **NEW** seatbelt buckle into position on the seat (Figure 9).
2. Tighten the **NEW** bolt provided with the buckle to 48 N·m (35 Ft. Lbs.).

NOTE: Care should be used when moving the seats to protect the interior trim.

3. Roll the seat back into position on the floor.
4. Install the marriage bracket to the seats (2) (Figure 8). Install **NEW** screws (1) into the marriage bracket (3) and tighten to 28 N·m (21 Ft. Lbs.).
5. Secure the wire harness retainer (4) to the marriage bracket (3) (Figure 8).
6. Install the third row left seat to floor nuts (1) and tighten to M10X1.50 to 50 N·m (37 Ft. Lbs.) and M12X1.75 to 70 N·m (52 Ft. Lbs.) (Figure 7).
7. Install the **NEW** third row left seat to floor nuts and/or bolts (2) and tighten to 50 N·m (37 Ft. Lbs.) (Figure 6).
8. Install the seat fastener covers.
9. Install the rear air duct (1) to the vehicle and engage the retaining tabs (Figure 5).

Third Row Center Seatbelt Buckle (60%)

E. Remove

1. As needed, disengage the retaining tabs and remove the rear air duct (1) from the vehicle (Figure 10).

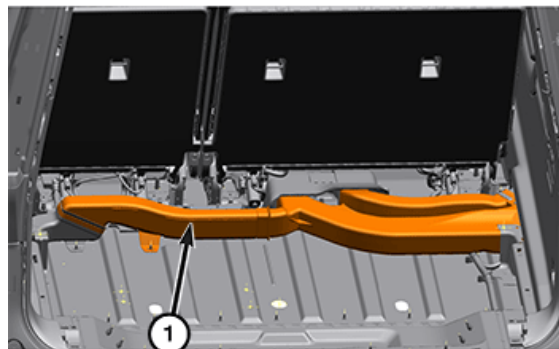

2319195619

Figure 10 – Third Row Left Outer Seat Bolts

2. Remove the third row right outer seat to floor fastener covers and nuts and/or bolts (2) from the front position. **Discard the bolts** (Figure 11).
3. Position the seats to the upright position.

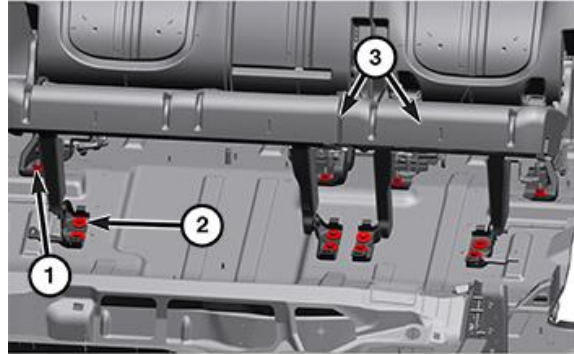

2319195623

Figure 11 – Third Row Right Outer Seat Bolts

4. Remove the third row seat to floor nuts (1) from the rear position (Figure 12).

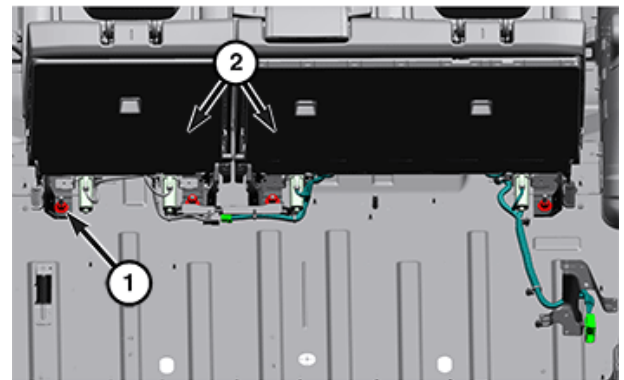

2319195621

Figure 12 – Right Outer Seat Nuts

SAFETY RECALL

NORTH AMERICA

Seatbelt Buckle



Reference: A7A / NHTSA 23V-716

FCA US LLC

5. Disengage the wire harness retainer (4) from the marriage bracket (3) (Figure 13).
6. Remove the screws (1) from the marriage bracket (3) and remove the bracket from the seats (2). **Discard the screws** (Figure 13).

NOTE: Care should be used when moving the seats to protect the interior trim.

NOTE: While removed, do not fold the seat backs down or recline the seat. This will cause the seats to become out of sync to each other, and this condition cannot be corrected.

NOTE: Ensure the seat is in the upright position and not folded flat when removing from vehicle. The 40% and 60% seats can be serviced separately but must remain in the upright/locked position during the whole time it is removed from the vehicle.

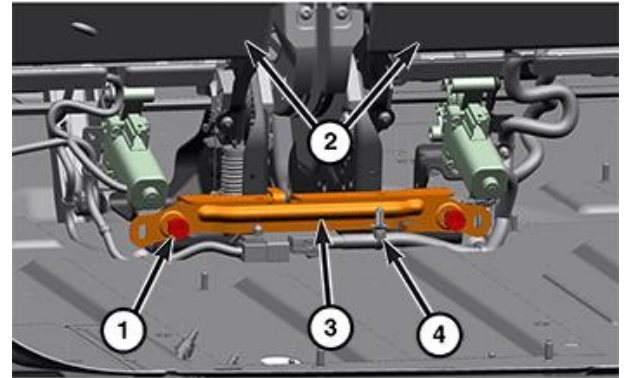

2319195624

Figure 13 – Marriage Bracket Fasteners

7. Roll the seat forward into the footwell.
8. Remove the third row center seatbelt buckle bolt (1) from the buckle anchor (Figure 14).
9. Roll the seat back onto the floor.
10. Raise the lower seat cushion.
11. Remove the buckle (2) from the seat (Figure 14).



1023170226

Figure 14 – Seatbelt Buckle Fastener

F. Install

1. Place the **NEW** seatbelt buckle into position on the seat (Figure 14).
2. Lower the seat cushion.

NOTE: Care should be used when moving the seats to protect the interior trim.

3. Roll the seat forward into the footwell.
4. Tighten the **NEW** bolt provided with the buckle to 48 N·m (35 Ft. Lbs.) (Figure 14).
5. Roll the seat back onto the floor.
6. Install the marriage bracket to the seats (2) (Figure 13). Install **NEW** screws (1) into the marriage bracket (3) and tighten to 28 N·m (21 Ft. Lbs.).
7. Secure the wire harness retainer (4) to the marriage bracket (3) (Figure 13).
8. Install the third row left seat to floor nuts (1) and tighten to M10X1.50 to 50 N·m (37 Ft. Lbs.) and M12X1.75 to 70 N·m (52 Ft. Lbs.) (Figure 12).
9. Install the **NEW** third row right seat to floor nuts and/or bolts (2) and tighten to 50 N·m (37 Ft. Lbs.) (Figure 11).
10. Install the seat fastener covers.
11. Install the rear air duct (1) to the vehicle and engage the retaining tabs (Figure 10).

Both Third Row Left Seatbelt Buckle (40%) and Third Row Center Seatbelt Buckle (60%)

G. Remove

1. As needed, disengage the retaining tabs and remove the rear air duct (1) from the vehicle (Figure 5).
2. Remove the third row left outer seat to floor fastener covers and nuts and/or bolts (2) from the front position. Discard the old bolts. (Figure 6).
3. Remove the third row seat to floor nuts (1) from the rear position (Figure 7).
4. Disengage the wire harness retainer (4) from the marriage bracket (3) (Figure 8).
5. Remove the screws (1) from the marriage bracket (3) and remove the bracket from the seats (2). Discard the screws (Figure 8).

NOTE: Care should be used when moving the seats to protect the interior trim.

NOTE: While removed, do not fold the seat backs down or recline the seat. This will cause the seats to become out of sync to each other, and this condition cannot be corrected.

NOTE: Ensure the seat is in the upright position and not folded flat when removing from vehicle. The 40% and 60% seats can be serviced separately but must remain in the upright/locked position during the whole time it is removed from the vehicle.

6. Roll the seat forward into the footwell.
7. Remove the third row left seatbelt buckle bolt (1) from the buckle anchor (Figure 9).
8. Remove the buckle (2) from the vehicle (Figure 9).
9. Remove the third row right seat to floor fastener covers and nuts and/or bolts (2) from the front position. Discard the bolts. (Figure 11).
10. Position the seats to the upright position.

NOTE: Care should be used when moving the seats to protect the interior trim.

NOTE: While removed, do not fold the seat backs down or recline the seat. This will cause the seats to become out of sync to each other, and this condition cannot be corrected.

NOTE: Ensure the seat is in the upright position and not folded flat when removing from vehicle. The 40% and 60% seats can be serviced separately but must remain in the upright/locked position during the whole time it is removed from the vehicle.

11. Remove the third row center seatbelt buckle bolt (1) from the buckle anchor (Figure 14).
12. Raise the lower seat cushion.

13. Remove the buckle (2) from the seat (Figure 14).

H. Install

1. Place the **NEW** center seatbelt buckle into position on the third row right seat (Figure 14).
2. Lower the seat cushion.

NOTE: Care should be used when moving the seats to protect the interior trim.

3. Tighten the **NEW** bolt provided with the buckle to 48 N·m (35 Ft. Lbs.) (Figure 14).
4. Install the **NEW** third row right seat to floor nuts and/or bolts (2) and tighten to 50 N·m (37 Ft. Lbs.) (Figure 11).
5. Install the seat fastener covers.
6. Place the **NEW** third row left seat seatbelt buckle into position on the seat (Figure 9).
7. Tighten the **NEW** bolt provided with the buckle to 48 N·m (35 Ft. Lbs.).

NOTE: Care should be used when moving the seats to protect the interior trim.

8. Roll the seat back into position on the floor.
9. Install the marriage bracket to the seats (2) (Figure 8). Install **NEW** screws (1) into the marriage bracket (3) and tighten to 28 N·m (21 Ft. Lbs.).
10. Secure the wire harness retainer (4) to the marriage bracket (3) (Figure 8).
11. Install the third row seat to floor nuts (1) and tighten M10X1.50 to 50 N·m (37 Ft. Lbs.) and M12X1.75 to 70 N·m (52 Ft. Lbs.) (Figure 7).
12. Install the **NEW** third row right outer seat to floor bolt bolts (2) and tighten to 50 N·m (37 Ft. Lbs.) (Figure 6).
13. Install the seat fastener covers.
14. Install the rear air duct (1) to the vehicle and engage the retaining tabs (Figure 5).

I. Install Cargo Load Floor (All Seating Positions)

1. Place the cargo load floor (1) into the vehicle (Figure 4).
2. Install the bolts (1) and nuts (2) that secure the cargo load floor (3) to the body and tighten the bolts to 11 N·m (8 Ft. Lbs.) and the nuts to 7 N·m (62 In. Lbs.) (Figure 3).
3. Close the cargo floor cover.
4. Long Wheelbase vehicle - Install the fasteners that secure the cargo rails to the rear floor (Figure 2).
5. Align and secure the retaining clips that secure the liftgate sill scuff plate to the rear sill (Figure 1).
6. Close the liftgate.

SAFETY RECALL

NORTH AMERICA

Seatbelt Buckle



Reference: A7A / NHTSA 23V-716

FCA US LLC



November 2023

Customer 3rd Row Passenger Seat Use Information

Your dealership has inspected the seatbelt buckles in accordance with the Safety Recall A7A Inspection Procedure. We would like to notify you that one or more of the seat belts has failed the inspection.

Drivers can continue to safely operate this vehicle, provided no occupants are positioned in the 3rd row seat(s) indicated below as "NOK".



The parts to correct this condition were not immediately available. We are making every effort to send the required parts as quickly as possible and will service your vehicle free of charge (parts and labor).

Your dealership will contact you when the parts become available to schedule a service appointment. We appreciate your patience.

We apologize for any inconvenience, but are sincerely concerned about your safety. Thank you for your attention to this important matter.

Customer Assistance/Field Operations
FCA US LLC

© Copyright 2023, FCA US LLC, All Rights Reserved

Strictly respect STELLANTIS Group safety, cleanliness, and environmental instructions for any vehicle service.
Document exclusively reserved for dealer information. Internal distribution to be ensured by dealer.
Reproduction forbidden without the written agreement of STELLANTIS Group. (C) 2023 STELLANTIS Group. All Rights Reserved

(dit)

This notice applies to your vehicle,

[Model Year and Model]

VIN XXXXXXXXXXXXXXXXXXXX

A7A/NHTSA 23V-716

LOGO

VEHICLE PICTURE

YOUR SCHEDULING OPTIONS

1. RECOMMENDED OPTION

Call your authorized Chrysler / Dodge / Jeep® / RAM Dealership.

2. Call the FCA Recall Assistance Center at 1-800-853-1403. An agent can confirm part availability and help schedule an appointment.

3. Visit recalls.mopar.com, scan the QR code below, or download the Mopar Owner’s Companion App.

QR Code

Get access to recall notifications, locate your nearest dealer, and more through this website or Mopar Owner’s Companion App. You will be asked to provide your Vehicle Identification Number (VIN) to protect and verify your identity. The last eight characters of your VIN are provided above.

DEALERSHIP INSTRUCTIONS

Please reference Safety Recall A7A.

IMPORTANT SAFETY RECALL

Seatbelt Buckle

Dear [Name],

This notice is sent to you in accordance with the National Traffic and Motor Vehicle Safety Act.

FCA US LLC has decided that certain [2022-2024 model year (WS) Wagoneer and Grand Wagoneer] vehicles fail to conform to Federal Motor Vehicle Safety Standard (FMVSS) No. 571.208 – Occupant Crash Protection.

Federal Motor Vehicle Safety Standard ("FMVSS") No. 571.208 Occupant crash protection. S7.2 Latch mechanism. states that "...each seat belt assembly installed in any vehicle shall have a latch mechanism that complies with the requirements specified in S7.2(a) through (d), [about accessibility and function for release]...". FMVSS No. 571.209 Seat belt assemblies. S4.4 Requirements for assembly performance. ...(b) states "Type 2 seat belt assembly. ... a Type 2 seat belt assembly including webbing, straps, buckles, adjustment and attachment hardware, and retractors shall comply with the following requirements when tested by the procedure specified in S5.3(b): (1) The structural components in the pelvic restraint shall withstand ... 11,120 N." Suspect vehicles may not allow occupants to properly access or fasten the seat belt to the buckle.

It is extremely important to take steps now to repair your vehicle to ensure the safety of you and your passengers.

WHY DOES MY VEHICLE NEED REPAIRS?

The third row seatbelt buckles on your vehicle ^[1] may be inaccessible or damaged. An inaccessible or damaged buckle may leave the occupant unable to fasten the seat belt. **If this warning is not heeded, an unfastened seat belt may increase the risk of injury to occupants during certain types of crashes.**

HOW DO I RESOLVE THIS IMPORTANT SAFETY ISSUE?

FCA US will repair your vehicle ^[2] free of charge (parts and labor). To do this, your dealer will inspect and, if necessary, replace the third-row seat belt buckle. The estimated repair time is one hour. In addition, your dealer will require your vehicle for proper check-in, preparation, and check-out during your visit, which may require more time. Your time is important to us, so we recommend that you schedule a service appointment to minimize your inconvenience. Please bring this letter with you to your dealership.

TO SCHEDULE YOUR FREE REPAIR, CALL YOUR CHRYSLER, DODGE, JEEP OR RAM DEALER TODAY

WHAT IF I ALREADY PAID TO HAVE THIS REPAIR COMPLETED?

If you have already experienced this specific condition and have paid to have it repaired, you may visit www.fcarecallreimbursement.com to submit your reimbursement request online. ^[3] Once we receive and verify the required documents, reimbursement will be sent to you within 60 days. If you have had previous repairs performed and/or already received reimbursement, you may still need to have the recall repair performed.

We apologize for any inconvenience, but are sincerely concerned about your safety. Thank you for your attention to this important matter.

Customer Assistance/Field Operations
FCA US LLC



Mr. Mrs. Customer
1234 Main Street
Hometown, MI 48371

[1] If you no longer own this vehicle, please help us update our records. Call the FCA Recall Assistance Center at 1-800-853-1403 to update your information.

[2] If your dealer fails or is unable to remedy this defect without charge and within a reasonable time, you may submit a written complaint to the Administrator, National Highway Traffic Safety Administration, 1200 New Jersey Ave., S.E., Washington, DC 20590, or you can call the toll-free Vehicle Safety Hotline at 1-888-327-4236 (TTY 1-800-424-9153), or go to safercar.gov.

[3] You can also mail in your original receipts and proof of payment to the following address for reimbursement consideration: FCA Customer Assistance, P.O. Box 21-8004, Auburn Hills, MI 48321-8007, Attention: Recall Reimbursement.

Note to lessors receiving this recall notice: Federal regulation requires that you forward this recall notice to the lessee within 10 days.