

# Era Awning Rework: Recall #179

## Parts Kit required: RC7925-24-779 ERA Awning Deployment

1. Wire Asm-Awning, Sprinter - 000293786 / 358844-01-000 (1)
2. 15A Breaker – 093654-02-000 (2)
3. Breaker spacer – 141789-01-000 (1)
4. Buss bar – 141744-01-000 (1)
5. Screw – 000G52-06-05B – For 15a breaker (1)
6. Screw – 000G19-10-08B – Replacement for 40a breaker (1)
7. Screw – 000g39-08-12B – For mounting relay module (2)
8. Label – 358911-01-000 (1)
9. Relay module – 358741-01-000 (1)
10. Small zip ties - 0008343-03-000 (14)
11. Adhesive zip tie mount - 357004-01-000 (4)
12. Pal Nut – 112722-01-01A (2)
13. Screws M4 X 20 – 339810-01-703 (2)
14. Screws #8 x 1", T20 – 339810-01-704 (5)
15. Carefree RH Motor Wedge – 339810-01-702 (1)

1



2



3



4



5



6



7



8



9



10



11



12



13



14



15



# ERA Awning Rework:

Read the entire instructions carefully before starting the procedure. If you have any questions, please contact Winnebago Industries Technical Service Department by calling 1-866-653-4329 or by email: [techservice@wgo.net](mailto:techservice@wgo.net). This document is confidential and is intended for dealer use only.

## Tools and Shop Supplies required-

1. Screw gun with #2 Philips and T25 Torx bit.
2. Cutting tool.
3. Cartridge gun.
4. Drill
5. Fish tape
6. Wire stripper/crimper
7. Manus Sealant – 185987-03-02A or equivalent
8. Electrical Tape
9. Torque Wrench, Ratchet, 7mm, 9mm, 10mm, 11/32" and E12 Sockets
10. Pick
11. Flat Screwdriver



# Step 1 – Disconnect all power sources from the coach.

1. Disconnect 110v shore power from the coach.
2. Turn off the 12v house disconnect switch – See Image 1.
3. Disconnect the 12v chassis battery ground (Quick disconnect is located behind a closeout panel next to the throttle, if applicable) – See Image 2. If the unit doesn't have the quick disconnect, refer to the sprinter user manual to disconnect the ground cable from the battery.
4. **NOTE:** If the chassis battery ground is not disconnected before performing the rework, chassis faults may occur that will require a Mercedes service center. This cost is not covered under this recall.

Image 1



Image 2



## Step 2 – Remove Driver and Passenger seat

1. Disconnect the seat power and airbag connectors from both seats – See Image 1.
  - **Note:** Take a moment to take pictures or otherwise mark the mounting locations of the seat harness, as well as its routing through the swivel seat base. Failure to properly reinstall the harness could result in damage to the harness.
2. Remove the 4 mounting bolts from each seat using the E12 Socket – See Image 2 & 3.
3. Remove the seats from the vehicle and remove the seat pedestal foam covers.

Image 1 – connectors are directly below seat swivel release

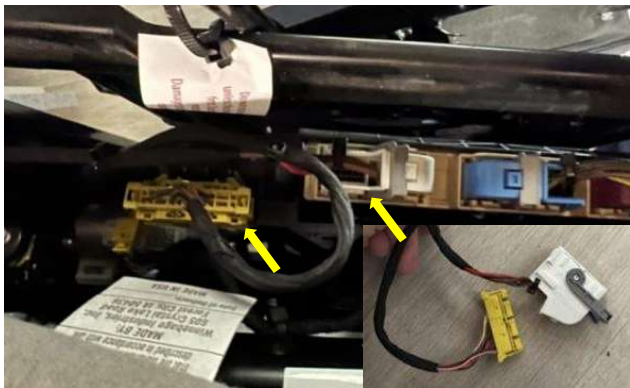

Image 2 – Seat attached to base.



Image 3 – Seat removed from base.





# Step 3 – Remove Driver/Passenger flooring

1. Using the T25 bit, remove the passenger stepwell top trim piece – See Image 1.
2. Using the pick, remove the 3 hidden caps from the passenger stepwell to expose the screws, remove the screws and stepwell cover – See Image 2.
3. Remove the floor covering in front of the driver's seat and fold back the floor covering between the driver and passenger seat to expose the black metal tray cover mounted between the seats – See Image 3.
4. Remove the metal tray cover by removing (2) 9mm pal nuts and (1) 10mm nut. Use pliers or a flathead screwdriver to carefully pry the tabs from the chassis studs. See Image 3 for fastener locations, and Image 4 after removal (typical view shown without any Winnebago wiring).

Image 1



Image 2



Image 3



Image 4



# Step 4 – Connect new awning circuits in driver's seat pedestal.

1. In the driver's seat pedestal, remove (2) 10mm fasteners that hold down the plastic Mercedes module carrier and fold the carrier over toward the driver's door – see Image 1 and then 2.
2. Starting in the passenger seat base, route harness 358844-01-000 (circuits FM, KE and AEZ) through the lower seat base notch, wire track, and into the driver's seat base – see Image 3.
3. Locate the Mercedes ground stud in the driver's seat base. Remove the 10mm nut, add circuit FM and torque to 71 In/Lbs. – See Image 4.

Image 1



Image 2

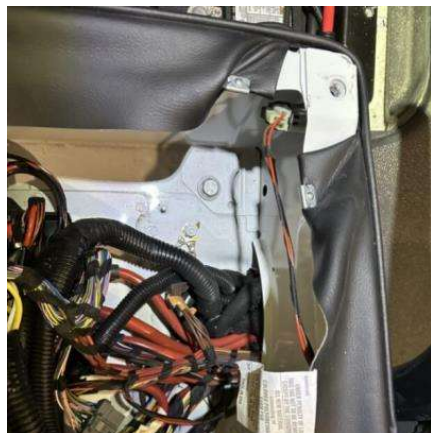
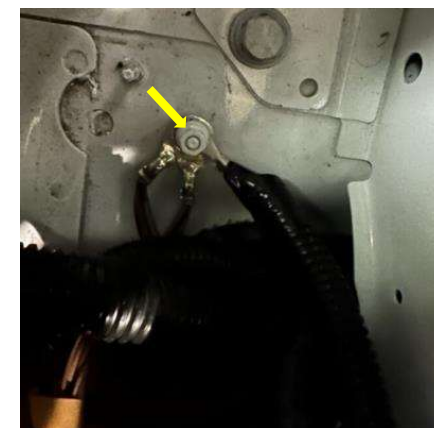

Image 3



Image 4





## Step 4 – Continued.

1. In the driver's seat pedestal, flip back over the Mercedes module carrier and reconnect the 10mm fasteners.
2. locate the Mercedes 3 position connection bar – Image 1. Pop open cover – Image 2 and remove the nut from the 4mm stud with a 7mm socket add circuit KE and torque stud to 22 In/Lbs. – See Image 3.
3. Locate the Mercedes PSM module – see Image 4
4. Locate circuit AEZ exiting the Mercedes PSM module, cut circuit AEZ 6" from the module and splice in the AEZ "Y" from the awning harness – see Image 5.
5. The work under the driver's seat is completed.

Image 1

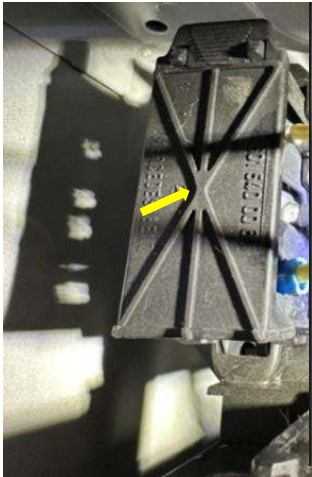

Image 2



Image 3

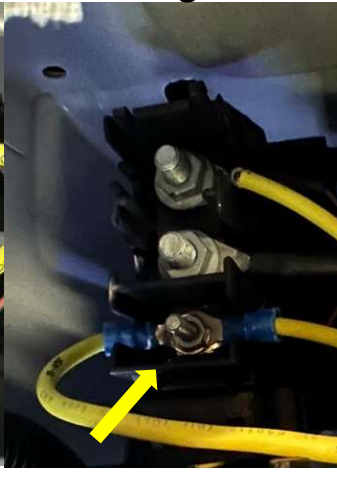
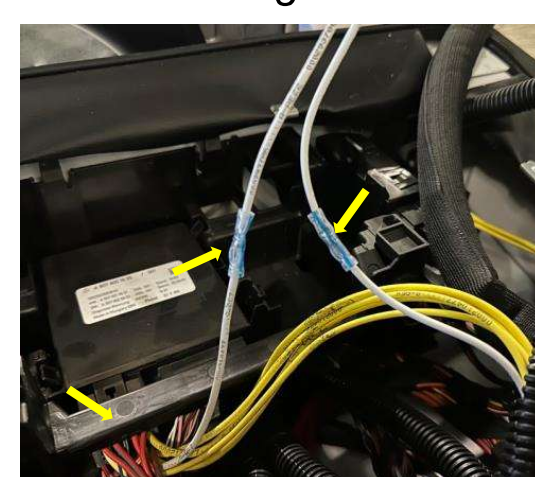

Image 4



Image 5



# Step 5 – Connect new awning circuits in passenger's seat pedestal.

Image 1



1. Locate the Winnebago 12v breaker panel under passenger's seat and remove the plug from the "Slideout" position – see Image 1, Yellow arrow, also replace the 6-amp breaker in the "Chassis Battery Power" position with a 15-amp breaker - 093654-02-000 as required – Image 1, Blue arrow.
2. Add new label 358911-01-000 over the top of the old label and gather all the components shown in Image 2.
3. Remove circuit KKF "Yellow Feed" circuit from the 40a "Coach breaker Panel" (lower connection) and discard the screw. Add new 15a breaker, plastic breaker spacer (for alignment) and buss bar to connect the 40a and 15a breaker together – see Image 3 Rear and Image 4 (Front).
4. Connect new circuit ED to the new 15a breaker "Awning Coach" and remove circuit TD from the breaker labeled "Awning Chassis". Circuit TD that was removed from the breaker will tie into new circuit FFT on the awning harness (Male to Female spade connection) and new circuit CGD will connect to the breaker labeled "Awning Chassis" – See Image 5.

Image 2



Image 3

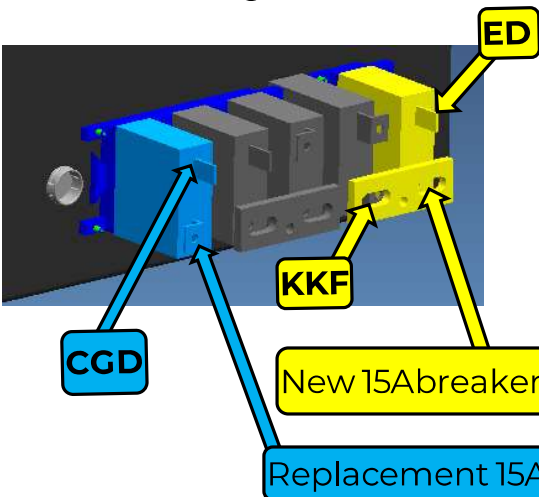
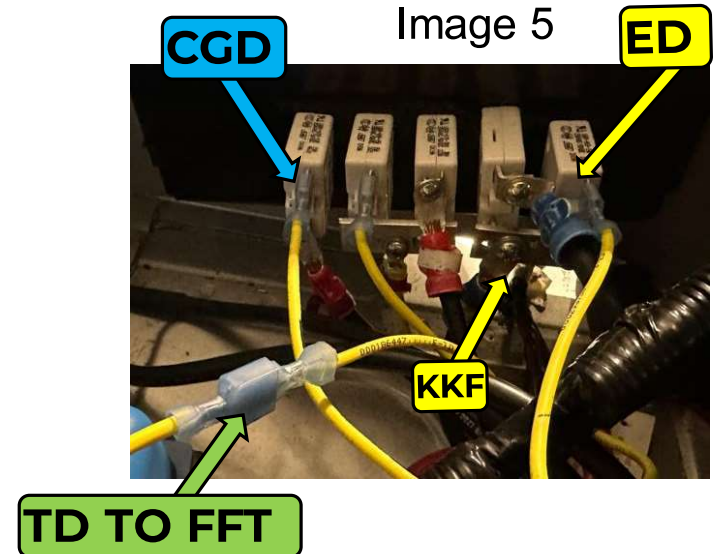

Image 4



Image 5





# Step 5 – Continued.

1. Mount the relay module in the passenger's seat pedestal with (2) G39-08-12B screws and connect the 9-pin housing to the relay module – see Image 1. Use zip ties to immobilize all the new circuits.
2. Set lockout voltage dip switch on the relay board to “Down” or GROUND as shown in Image 2. This will enable the RTL (Retract Then Lock) function of the awning. RTL = If the awning is extended, starting the engine will automatically retract the awning.
3. Route circuits AWP, FFT, ASY and FM through the lower slot in the passenger's seat pedestal – see Image 3. Follow the existing Mercedes wiring into and behind the B-Pillar cover.

Image 1



Image 2



Image 3

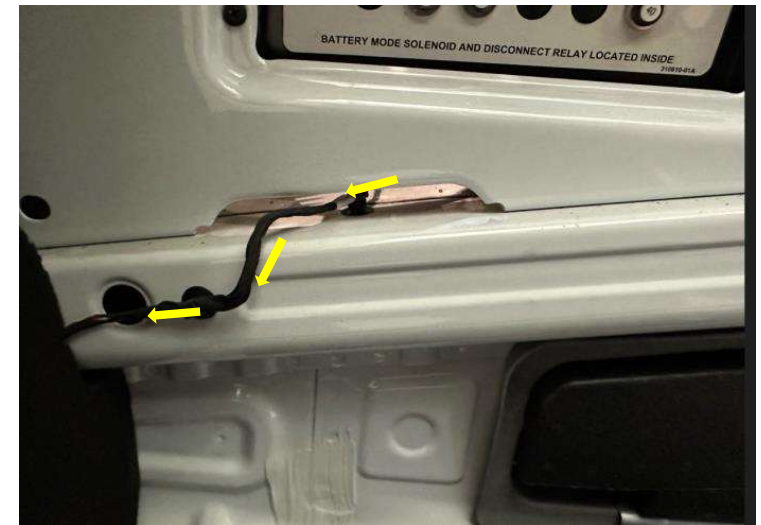

# Step 6 – Route harness up B-Pillar cover to BT-12

1. Use a pick to remove the cover caps and screw gun to remove the fasteners from the following components-
  1. Passenger side upper transition panel - (4 caps and 4 Philips screws).
  2. Upper shelf support bracket – (2 Philips screws and 1 #20 torx)
  3. Passenger side B-Pillar cover – (17mm Socket and a #45 torx).
2. Retain all hardware to reinstall the components later.
3. Once all the bolts and screws are removed, you should be able to slide the top of the B-pillar out then lift to pull it away from the van body. This will allow you to route the harness up the rear side of the B-Pillar cover following the yellow arrows up to the BT-12 module.





# Step 8 – Connect the new harness to the BT-12 module

1. Pull down the BT12 module and cut the connections to the Red, Black and Green circuits – see Image 1.
  - a) If the unit doesn't have the Awning On/Off switch, cut the violet wire – See Image 1 & 2.
  - b) If the unit has the Awning On/Off switch, do not cut the violet wire – See Image 2.
2. Tape off the blunt end on the unused yellow and white wires.
3. Strip the BT12 Red, Black, Green and (Violet circuits if required) and connect them to the new harness in the following sequence –
  1. **AWP=Red**
  2. **FM=Black**
  3. **ASY=Green**
  4. **FFT=Violet - Only if the unit doesn't have the awning On/Off switch.**
4. Peel the red adhesive tape off the BT12 adhesive – see Image 3 and 4 and stick the module to the van body – see Image 5. Use zip ties to immobilize the new circuits and create a drip loop on the harness – Module high with wires exiting and looping down out of the module.

Image 5



Image 1

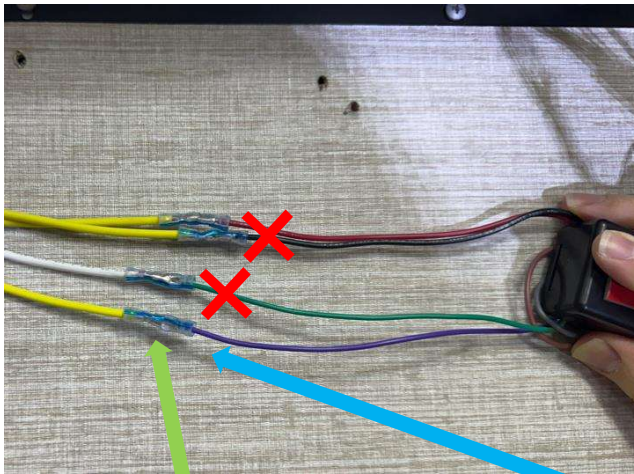

On units Without the Carefree On/Off switch, cut the Violet circuit and splice to FFT.

Image 2



Do **NOT** cut the violet circuit on units that have the Awning On/Off switch shown above. Violet will remain connected to TD-1

Image 3



Image 4

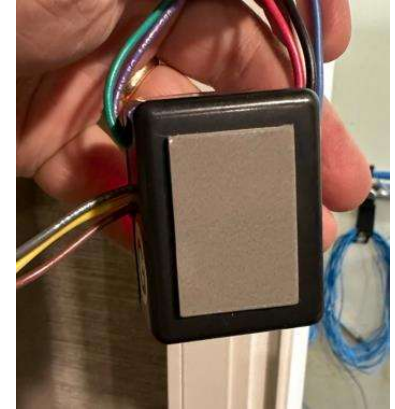



# Step 9 – Seal Awning Wire Passthrough

1. On the roof of the coach, locate the awning wiring entrance point - Front right corner of the roof.
2. Remove electrical tape wrap without damaging wires to gain access to the interior of the convolute tubing, see Image 1.
3. Insert nozzle of cartridge gun into convolute tubing as far into the coach as you can, seal the inside tubing back to 2 inches up from the roof, see Image 2. Ensure sealant oozes out to confirm the convolute is fully filled. Wipe off excess, prep, and retape convolute starting from the roof and wrapping up to the awning creating a shingled effect.
4. Using Manus, reseal on top of the existing self-leveling around the base of the convolute and tool to ensure no gaps are present, see Image 3.

Image 1



Image 2



Image 3



# Step 10 – Reinstall Driver and Passenger seat

1. Reinstall the Mercedes foam covers over driver and passenger seat pedestals and route seat harness out center hole – See Image 1.
  - **Note:** Ensure the seat harness route and retaining mounts are restored to factory location. Failure to properly reinstall the harness could result in damage to the harness.
2. Place the seat over the mounting holes and reinstall the 4 E12 mounting bolts –see Image 2. Torque the mounting bolts to 27 Ft/Lbs.
3. Reinstall the electrical connectors to the seat – see Image 3.

Image 1

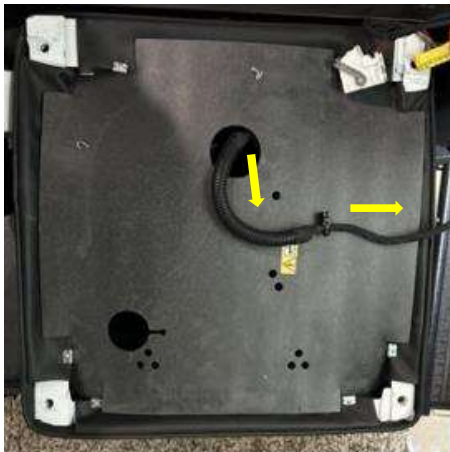

Image 2



Image 3



# Step 11 – Reconnect the 12v power sources.

1. Turn on the 12v house disconnect switch – See Image 1.
2. Reconnect the 12v chassis battery ground (Quick disconnect is located behind a closeout panel next to the throttle, if applicable) – See Image 2. If the unit doesn't have the quick disconnect, refer to the sprinter user manual to disconnect the ground cable from the battery.

Image 1



Image 2





# Step 12 – Awning Motor wedge and firmware update

1. Before performing the motor wedge installation, confirm that the awning installed requires a wedge, and that one is not already installed. When inspecting the awning be sure to check both sides for the motor, as depending on build it may be a right-hand or left-hand motor.
  1. Confirm that the awning is an angle gear motor, this style of motor is the one that requires the wedge. See Image 1 for an example of what the angle gear motor looks like with the awning extended. Tubular style motors, where the motor is housed inside the awning fabric roller, do not require a wedge.
  2. If the awning is an angle gear motor, gain access to the backside of the motor by removing the case end cap, see Image 2. Some coaches may require the mounting screws be removed and the awning to be slid back on the mounting extrusion in order to access the cover. When doing this be careful to not pop the awning out of the mounting extrusion as it could fully detach from the coach.
  3. Confirm that a wedge is not installed, Image 3 shows a motor with a wedge already installed.
  4. If your coach does not have the wedge and requires one, move onto the next page and follow the wedge installation.

Image 1



Image 2



Image 3

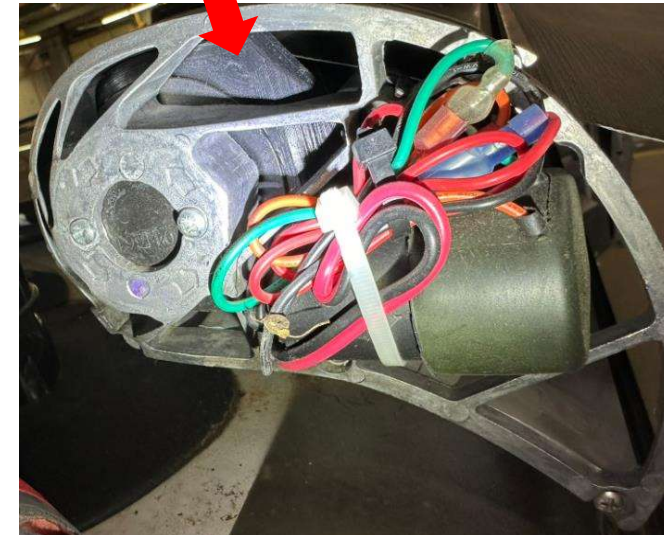

# Step 12 – Awning motor wedge and firmware update(Cont.)

1. Review and complete the following documents, all units with a BT-12 require a firmware update.
  - Carefree Motor Wedge Installation service manual, 056513-002R1(LH) or 056513-001R5(RH) . (For angle gear awnings without a wedge already installed)
  - Carefree Connects Firmware Update service manual, 056513-004r1 (All awning with a BT-12)



# Step 13 – System Testing

- See the chart in Image 1 and confirm that all 'With' situations result in the correct actions when the extend and retract commands are operated.
  - Note:** awning will need to be partially extended to confirm auto-retraction, see Image 2.
  - Note:** the relay module will hold the park brake signal from when the park brake is engaged until the engine is started or the module loses power. This is due to the chassis going to sleep and needing to hold the park brake signal.
- With the engine off and the parking brake and 12v coach power on, bring the awning to a partially extended position, see Image 2. Locate the edge of the awning with the wind sensor and shake the awning to simulate high winds. The awning should automatically retract when the sensor reads the awning movement.
- If all the above actions result in their defined outcomes the rework is complete.

Image 2



Image 1

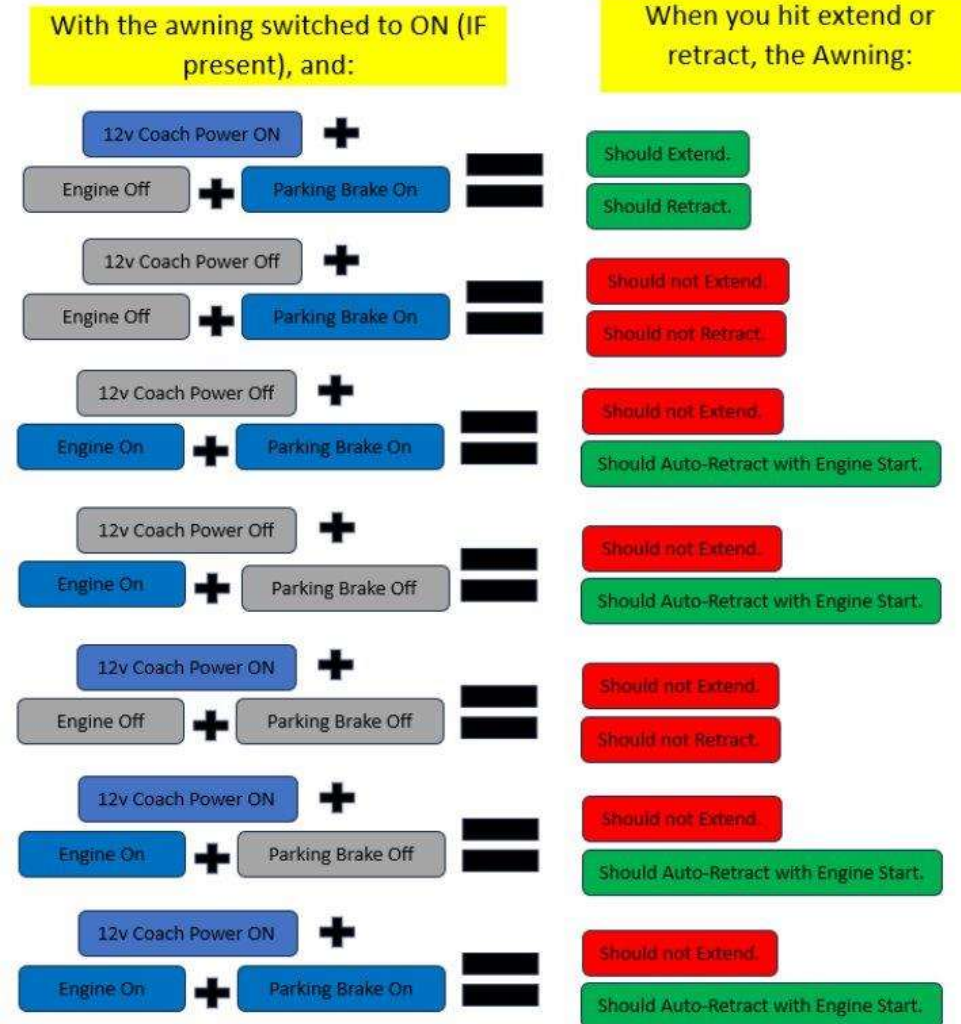



# Step 14 – Reinstall interior trim panels.

1. Locate the original fasteners and reinstall the interior trim panels in the following order.
  1. Passenger side upper transition panel - (4 caps and 4 Philips screws).
  2. Upper shelf support bracket – (2 Philips screws and 1 #20 torx)
  3. Passenger side B-Pillar cover – (17 mm socket and a #45 torx). Torque the 17mm fastener to **26 Ft/Lbs.** and the #45 torx fastener to **13 Ft/Lbs.**



# Step 15 – Reinstall Driver/Passenger flooring and stepwell covers.

1. With the metal tray cover removed, inspect the wiring running between the two seat pedestals, the center console area, and the chassis battery. See Image 1 below for all (6) locations where the Mercedes wire harness should be zip tied to the Mercedes plastic wire tray (typical view shown without any Winnebago wiring). If any of these locations do not have a zip tie preset, add one to secure the wiring.
2. On the sheet metal tray cover, add (2) adhesive zip tie mounts in area shown in Image 2. These zip ties will go around and secure the battery cable and any other Wiring going between the Chassis battery area and the driver side pedestal.

Image 1

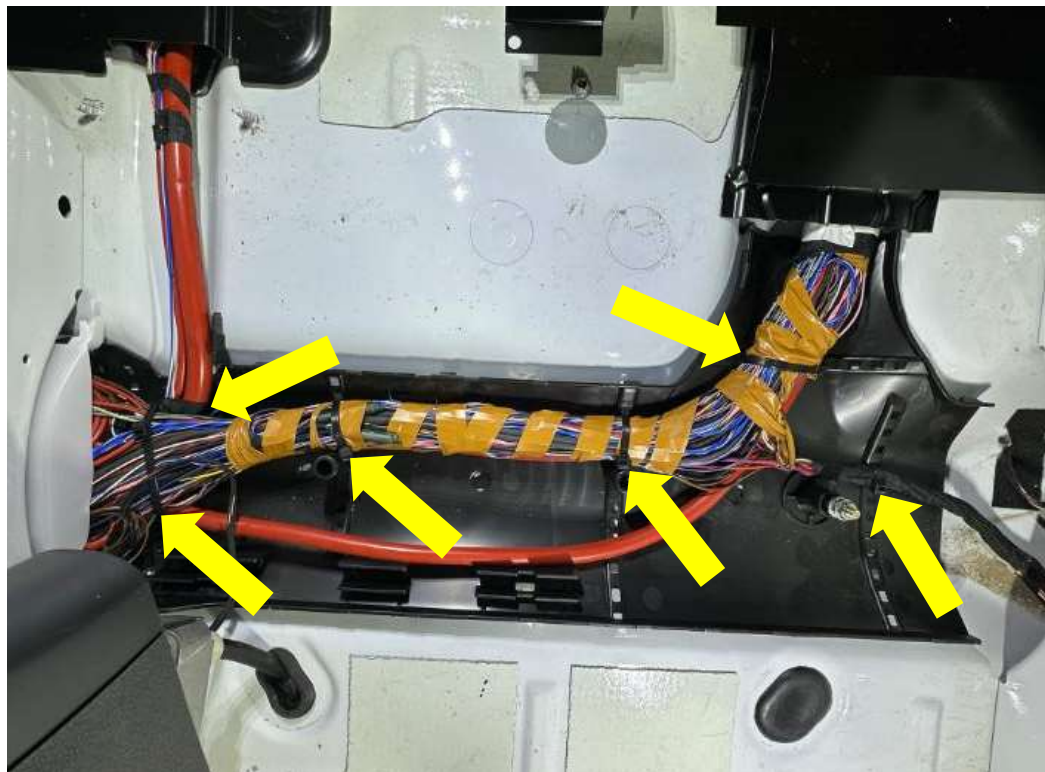

Image 2



# Step 15 – Reinstall Driver/Passenger flooring and stepwell covers.

1. Reinstall the metal tray cover over the wire track – See Image 1.
2. Pull the floor covering back over the wiring panel and tuck in back in place around the park brake handle.
3. Reinstall the passenger side stepwell cover, drivers side flooring and using the T25 bit, reinstall the driver and passenger stepwell top trim pieces – see Images 2 and 3.
4. The work is now completed.

Image 1



Image 2

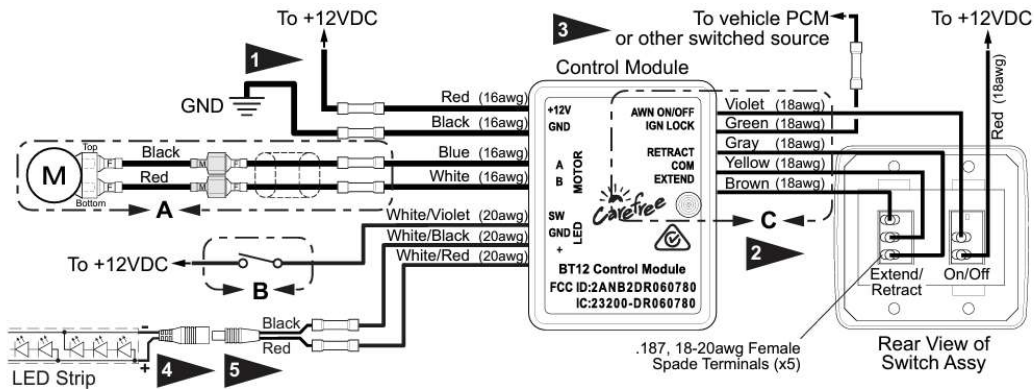

Image 3





# Generic Carefree BT-12 Wiring Diagram



# Winnebago BT 12 connection guide

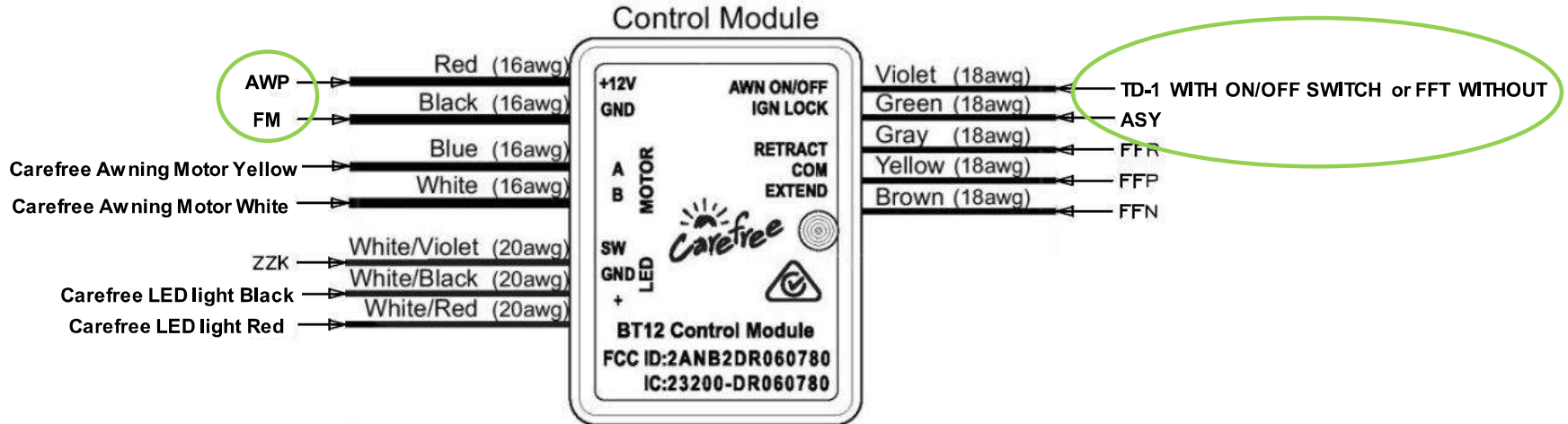

REV	ZONE	REVISION RECORD	DATE	OPTR-0103
A	---	INITIAL RELEASE	03/11/24	3572-2604
B	---	CHANGE WIRE COLOR & TERMINALS	03/25/24	3572-2604
C	---	CHANGE BRN TO BLS SLEEVING, MOVE OPTR	03/14/24	3572-2604

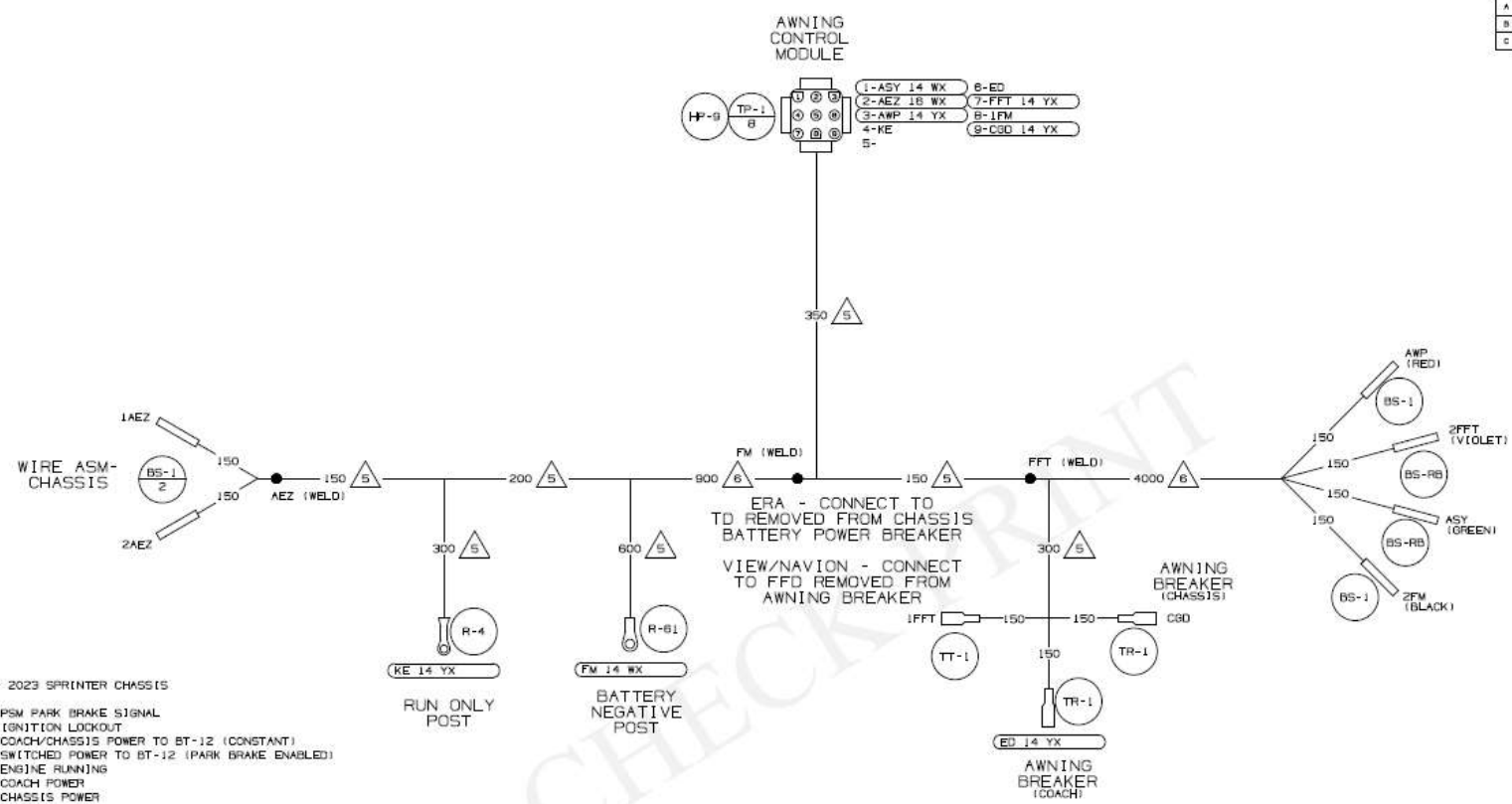

- △ B** 2020 - 2023 SPRINTER CHASSIS
- 7. AEZ - PSM PARK BRAKE SIGNAL
  - ASY - IGNITION LOCKOUT
  - AMP - COACH/CHASSIS POWER TO BT-12 (CONSTANT)
  - FFT - SWITCHED POWER TO BT-12 (PARK BRAKE ENABLED)
  - KE - ENGINE RUNNING
  - ED - COACH POWER
  - OD - CHASSIS POWER
  - FM - GROUND

- △ B** COVER WITH SLEEVE-BRAIDING 139049-02-000.
- △ B** COVER WITH MINIMUM POSSIBLE DIAMETER CONDUIT 41953-09, -10, -11, -13, -14, -16-000 AS REQUIRED. SECURE BOTH ENDS WITH TAPE 6363-01-000 TO WIRE ASM.

- 4. ALL WIRES W/O TERMINALS TO BE STRIPPED 10MM UNLESS OTHERWISE SPECIFIED.
- 3. DIMENSIONS SHOWN SHALL BE CONSIDERED AS BETWEEN CENTERS OF JUNCTIONS OR BRANCHES. DIMENSIONS SHOWN BETWEEN JUNCTIONS AND CONNECTIONS OR TERMINALS ARE TO END OF WIRE.

- 2. WIRE ASSEMBLY TO BE SECURED BY WRAP OF TAPE 610 MAX APART AND AT EACH JUNCTION OR BRANCH USING 7957-01-000 TAPE.

- △ 1** TOLERANCES TO BE AS FOLLOWS UNLESS OTHERWISE SPECIFIED:
- A. TOLERANCE OF CUT WIRE LENGTHS SHALL BE +13, -0 OR +1%, -0% WHICHEVER IS LARGER.
  - B. TOLERANCE BETWEEN JUNCTIONS OR BRANCHES SHALL BE +13, -0. SHALL NOT BE CUMULATIVE.

NOTES:

**X-X** FOR ELECTRICAL CALLOUTS SEE CWS 000229177 544479-01-000

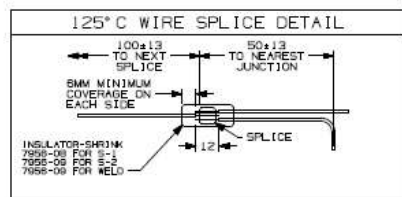

**WINNEBAGO**  
 COPYRIGHT 2024 WINNEBAGO INDUSTRIES, INC.

DRN: A, STORKA	ALL DIMENSIONS ARE IN MILLIMETERS
OPTR: S, UNGER	DATE: 03/11/24
SPECIFIED TOLERANCES	UNLESS OTHERWISE SPECIFIED
FINISH: 05, 06, 07, 08, 09, 10, 11, 12, 13, 14, 15, 16, 17, 18, 19, 20, 21, 22, 23, 24, 25, 26, 27, 28, 29, 30, 31, 32, 33, 34, 35, 36, 37, 38, 39, 40, 41, 42, 43, 44, 45, 46, 47, 48, 49, 50, 51, 52, 53, 54, 55, 56, 57, 58, 59, 60, 61, 62, 63, 64, 65, 66, 67, 68, 69, 70, 71, 72, 73, 74, 75, 76, 77, 78, 79, 80, 81, 82, 83, 84, 85, 86, 87, 88, 89, 90, 91, 92, 93, 94, 95, 96, 97, 98, 99, 100	DATE: 03/11/24
REF: TO 800018 FOR FASTENER TIGHTENING GUIDELINES	REVISION: 1
WIRE ASM-AWNING, SPRINTER	
PART: 000293786 / 35884401000	
REV: 000291454E1	

Power relay switches between house and chassis battery. Normally Coach battery Engine run = chassis

Pulse On RELAY takes the park brake signal and powers the Hold Relay.

Hold Relay will hold the power from the Pulse ON Relay until the OFF Relay activates the coil and breaks the ground output to the coil

OFF Relay supplies power from the Pulse ON Relay coil until KE Engine Run breaks the ground circuit. It also feeds the BT12 12V- to auto retract and disable extend function

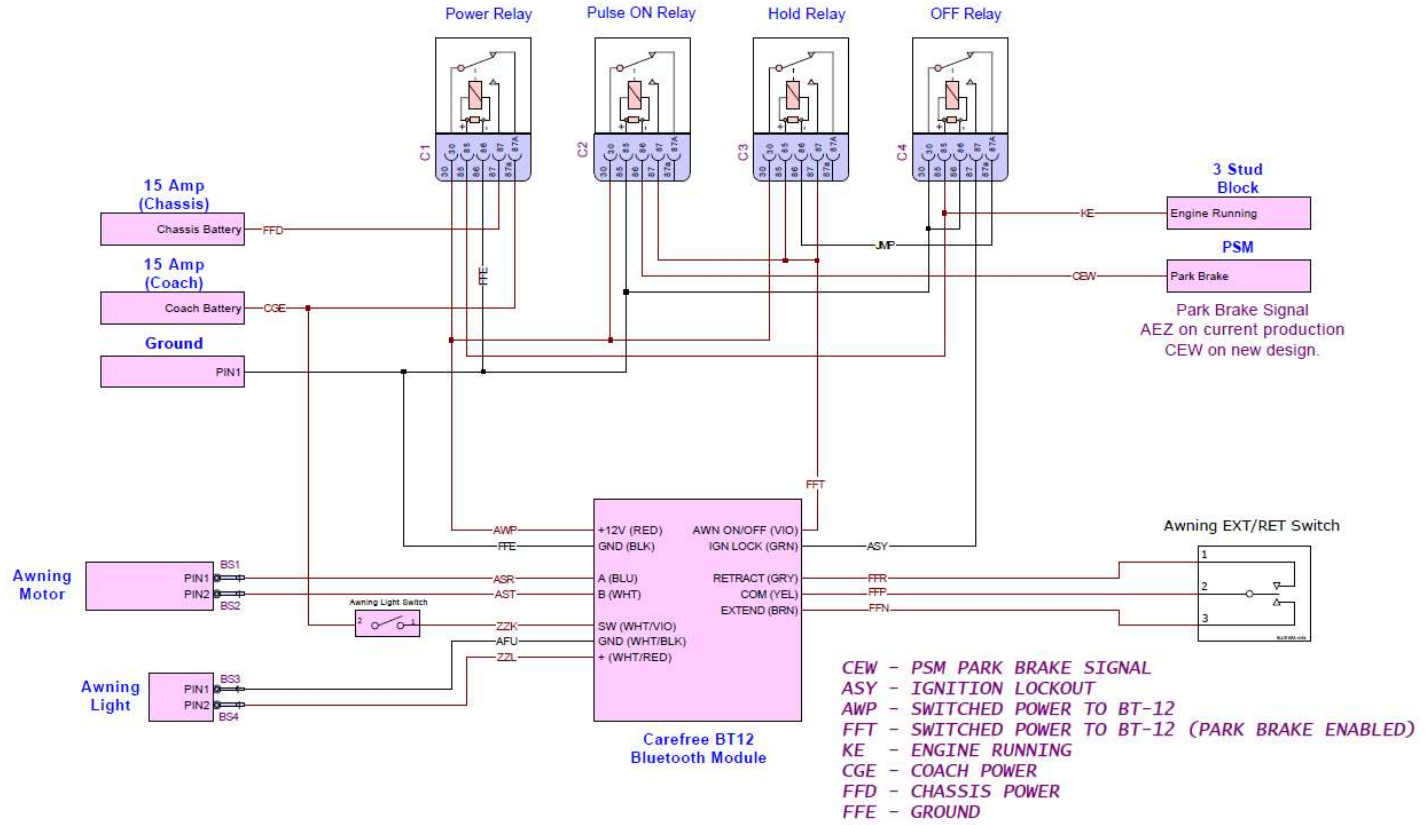

Read the entire instructions carefully before starting the procedure. if you have any questions, please contact Winnebago Industries Technical Service Department by calling 1-866-653-4329 or by email: [techservice@wgo.net](mailto:techservice@wgo.net). This document is confidential and is intended for dealer use only.