

- b. If the P-Clamp style **IS NOT** installed, proceed to step 3. File an **Repair** credit procedure using the appropriate table for Recall 0184 or 9184 depending on the VIN.

3. See Figure 1. Remove and retain screw (1).
4. Remove and discard Original Equipment (OE) brake line clamp (2).
5. See Figure 2. Install **new** P-Clamp (3) from recall kit (Part No. 91500116).
 - a. Make sure P-Clamp (3) is properly orientated.
6. Install screw (1). Tighten.
Torque: 9–11 N·m (80–97 **in-lbs**)

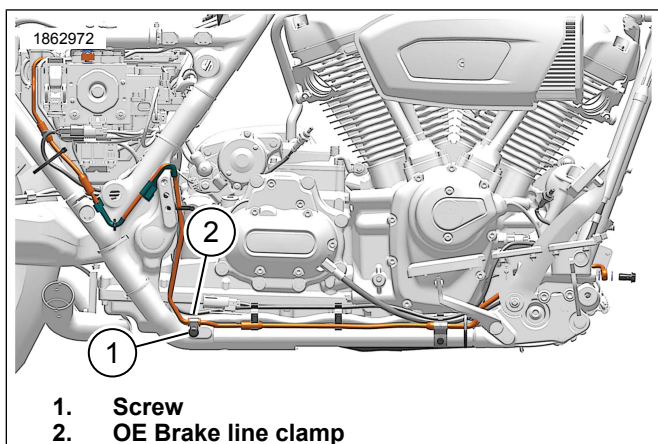

Figure 1. Rear Master Cylinder Brake Line (exhaust removed for clarity)

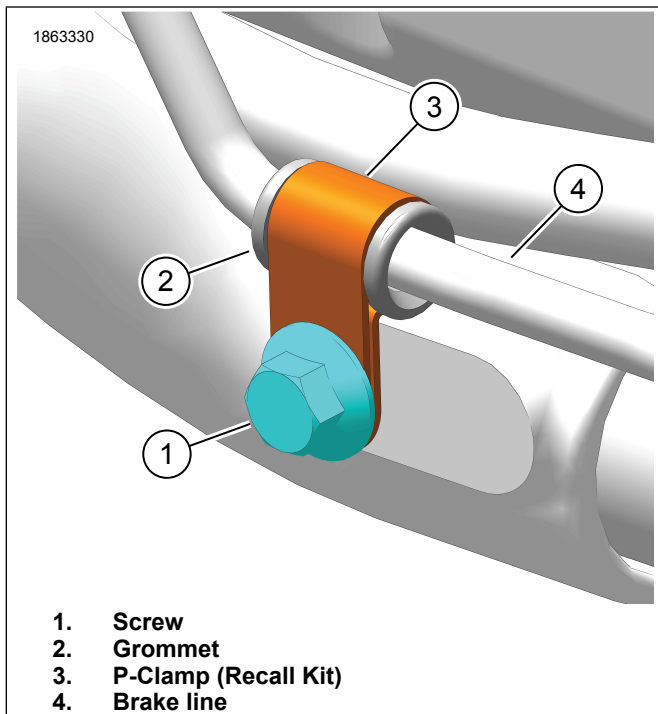

Figure 2. P-Clamp Orientation

Credit Procedure

NOTE

In the rare occurrence the brake line needs to be replaced, please file a separate claim with all necessary parts and labor, per normal warranty policy.

For each vehicle involved in this recall (involvement of VIN has been verified on h-dnet.com), submit a recall claim per Table 6.

Table 6. Credit Procedure: H-dnet.com and Talon System Users

ITEM	DATA
Claim Type	SRC
Problem Part Number	10800215
Quantity	Leave Blank
Primary Labor Code ⁽¹⁾	2714
Labor Time	0.1 hours
Customer Concern Code	0184
Condition Code	9981
Replacement Part Number	91500116
Quantity	1

(1) Download may be required

Upon submission of the properly completed claim, you will be credited for 0.1 hours of labor time for performing the procedure, plus appropriate administrative time. Credit will also be issued for the recall kit (U.S. only). Submit campaign events on their own warranty claim. Do not mix them with other warranty events.

Table 7. Credit Procedure: GDP/SAP System Users

ITEM	DATA
Claim Type	Recall Claim
Fix ID-Found in Recall Number	C
Problem Part Number	10800215
Customer Concern Code	0184
Condition Code	9981

Credit Procedures For Recall 9184

For each vehicle involved in this recall (involvement of VIN has been verified on h-dnet.com), submit a recall claim per Table 8. **INSPECTION ONLY.**

Table 8. Credit Procedure: H-dnet.com and Talon System Users

ITEM	DATA
Claim Type	SRC
Problem Part Number	10800215
Quantity	Leave Blank
Primary Labor Code ⁽¹⁾	2723
Labor Time	0.1 hours
Customer Concern Code	9184
Condition Code	9981

(1) Download may be required

Table 9. Credit Procedure: GDP/SAP System Users

ITEM	DATA
Claim Type	Recall Claim
Fix ID-Found in Recall Number	I
Problem Part Number	10800215
Customer Concern Code	9184
Condition Code	9981

Upon submission of the properly completed claim, you will be credited for 0.1 hours of labor time for performing the procedure, plus appropriate administrative time. Submit campaign events on their own warranty claim. Do not mix them with other warranty events.

For each vehicle involved in this recall (involvement of VIN has been verified on h-dnet.com), submit a recall claim per Table 10. **REPAIR.**

Table 10. Credit Procedure: H-dnet.com and Talon System Users

ITEM	DATA
Claim Type	SRC
Problem Part Number	10800215
Quantity	Leave Blank
Primary Labor Code ⁽¹⁾	2741
Labor Time	0.1 hours
Customer Concern Code	9184
Condition Code	9982
Replacement Part Number	91500116
Quantity	1
<i>(1) Download may be required</i>	

Table 11. Credit Procedure: GDP/SAP System Users

ITEM	DATA
Claim Type	Recall Claim
Fix ID-Found in Recall Number	C
Problem Part Number	10800215
Customer Concern Code	9184
Condition Code	9982

Upon submission of the properly completed claim, you will be credited for 0.1 hours of labor time for performing the procedure, plus appropriate administrative time. Credit will also be issued for the recall kit (U.S. only). Submit campaign events on their own warranty claim. Do not mix them with other warranty events.

Return Parts

Hold all claimed parts for 60 days from date of credit issued for possible field inspection and/or request to return to factory. After 60 days, destroy and discard the parts.