



GROUP	MODEL
Safety Recall Campaign	2011-2014MY Sorento (XMa)
NUMBER	DATE
SC284XM (Rev 1, 5/14/2024)	May 2024

SAFETY RECALL CAMPAIGN

HECU MULTI FUSE REPLACEMENT (SC284XM)

NOTICE

This bulletin has been revised to include additional information. New/revised sections of this bulletin are indicated by a black bar in the margin area.

This bulletin provides information to replace the multi fuse of the Hydraulic Electronic Control Unit (HECU) and install an updated junction box label on certain 2011-2014MY Sorento (XMa) vehicles produced from March 3, 2010 through June 14, 2013. An engine compartment fire may occur in the area where the HECU is located. The HECU may experience an internal electrical short circuit condition that can result in overcurrent, thereby increasing the risk of an engine compartment fire while the vehicle is driven or while parked. Dealers are to install new fuses to prevent an electrical short circuit condition in the HECU's electrical circuit board. Customers may experience illumination of the Malfunction Indicator Lamp (MIL), ABS warning light, burning/melting smell, and/or smoke from the engine compartment. Follow the procedure outlined in this publication to install a new multi fuse and junction box cover label on the applicable vehicle. Before conducting the procedure, verify that the vehicle is included in the list of affected VINs.

NOTICE

There is no charge to the vehicle owner for this repair. Under applicable law, you may not sell or otherwise deliver any affected vehicle until it has been repaired pursuant to the procedures set forth in this bulletin.

Repair status for a VIN is provided on KDealer+ (Service → Warranty Coverage → Warranty Coverage Inquiry → Campaign Information). Not completed Recall / Service Action reports are available on KDealer+ (Consumer Affairs → Not Completed Recall → Recall VIN → Select Report), which includes a list of affected vehicles.

Replacement Procedure:

1. Open the hood.
2. Disconnect the negative (-) battery terminal.
3. Remove the junction box fuse cover.

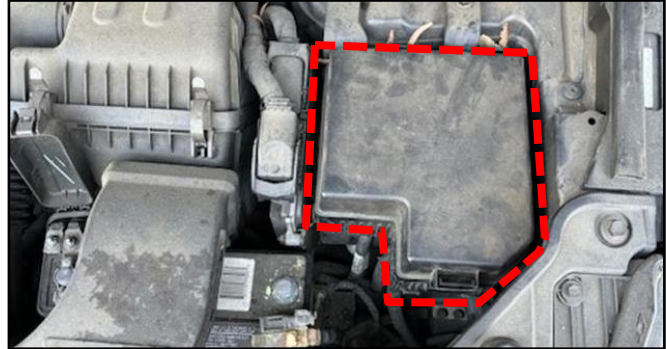

- 4a. Locate the Multi Fuse (A) for ABS1 and ABS2 and loosen the two (2) 10mm Multi Fuse retaining nuts (B) and remove the Multi Fuse.

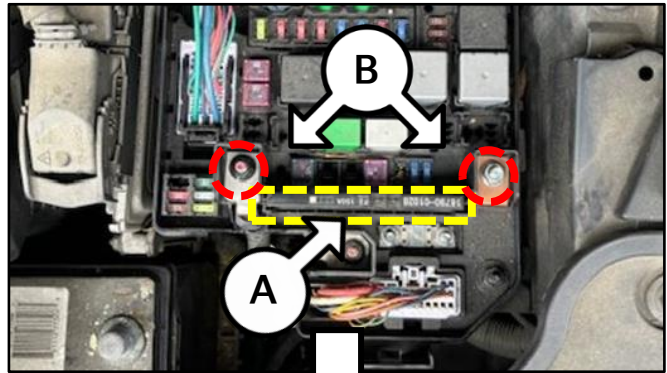

- 4b. Install the **new** Multi Fuse (A) and tighten the two (2) retaining nuts (B).

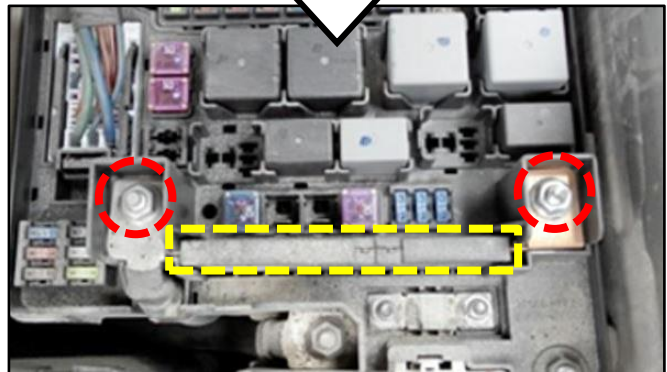

Tightening torque for retaining nut (B):
7.2 - 8.7 lb.ft (9.8 - 11.8 N.m)

Note: Drill a hole through the center of the removed Multi Fuse. DO NOT reuse.

5. Adhere the new ABS1 '30A' and ABS2 '30A' fuse labels to the bottom of the junction box fuse cover, as shown.

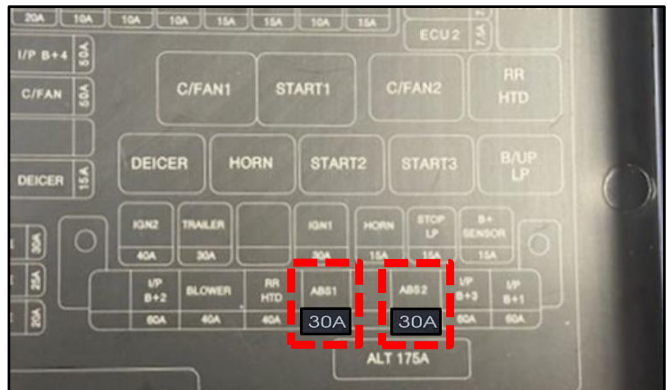

6. Reinstall all removed parts in reverse order of removal.





SUBJECT:

HECU MULTI FUSE REPLACEMENT (SC284XM)**AFFECTED VEHICLE RANGE:**

Model	Production Date Range
Sorento (XMa)	March 3, 2010 to June 14, 2013

REQUIRED PART:

Part Name	MY	Part Number	Figure	Qty.
Multi Fuse & Label Kit	11-13MY	91XM3 11000QQK	  	1
	14MY F/L (Face Lift)	91XM1 11200QQK	  	1

Note: Order Quantity will be controlled by a UIO% per dealer net submitted warranty claims. No VIN entry will be required. To keep the supply of parts flowing, please be sure to expedite warranty claim filing. As supply becomes more available, the maximum order quantity limit may be increased or removed.

WARRANTY INFORMATION:

N Code: N99 C Code: C99

Claim Type	Causal P/N	Qty.	Repair Description	Labor Op Code	Op Time	Replacement P/N	Qty.
R	58910 1U860	0	(SC284XM) HECU Multi Fuse and Label Kit Installation	241A04R1	0.3 M/H	91XM3 11000QQK or 91XM1 11200QQK	1

Note: Refer to [Warranty Bulletin 2024-29](#) for claim submission procedures. Manually enter sublet code 'X2' for reimbursement of one roundtrip rideshare expense or up to three (3) days of rental expense, with supporting documentation.

NOTICE

VIN inquiry data for this repair is provided for tracking purposes only. Kia retailers should reference SC284XM when accessing the KDealer+ system.

